

DORMER  PRAMET

TORNALAMA

2021 – 2022

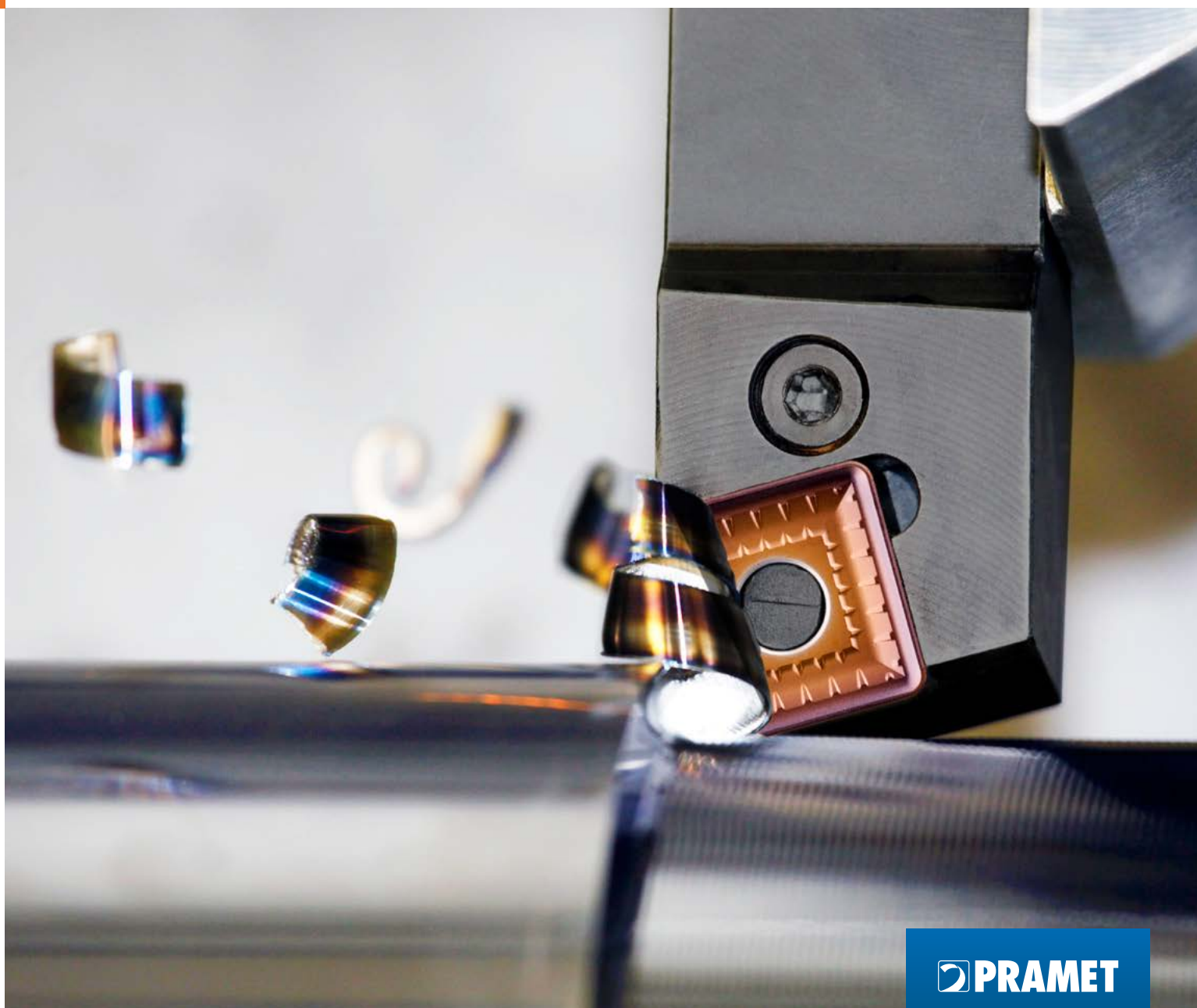



TORNALAMA – GENEL İÇERİK

6	ISO TORNALAMA	İŞ PARÇASI MALZEME GRUPLARI (WMG) VE ISO 13399
10		GENEL BİLGİLER
18		REHBER
57		POZİTİF KESİCİ UÇLAR
219		NEGATİF KESİCİ UÇLAR
386		KESME VE KANAL AÇMA
482		DİŞ TORNALAMA
528		BROŞLAMA
536		GENEL TEKNİK BİLGİLER



ÜRÜN GRUBU		ÜRÜN GRUBU		ÜRÜN GRUBU		ÜRÜN GRUBU	
C		DTGN(RL) EXT	346	PCLN(RL) EXT	247	SEUP(RL) INT	113
C.-DCLN(RL) EXT	249	DU, D	415, 441, 460, 467	PCLN(RL) INT	255	SEXP(RL) INT	114
C.-DCLN(RL) INT	257	DVJN(RL) EXT	360	PDJN(RL) EXT	274	SEXP(RL)-E INT	115
C.-DDJN(RL) EXT	277	DVPN(RL) EXT	361	PDNN(RL) EXT	275	SI(RL)	479, 524
C.-DDNN EXT	278	DVUN(RL) INT	364	PDUN(RL) INT	281	SI(RL)-S	526
C.-DDUN(RL) EXT	279	DWLN(RL) EXT	377	PDXN(RL) EXT	276	SRDC(RL) EXT	126
C.-DDUN(RL) INT	282	DWLN(RL) INT	382	PHZ	533	SRDCN EXT	127
C.-DRSN(RL) EXT	297	G		PHZ-2	534	SRSC(RL) EXT	128
C.-DSDNN EXT	324	GFI(RL) EXT	437	PLBN(RL) EXT	290	SSBC(RL) EXT	139
C.-DSKN(RL) EXT	325	GFIL-L AXIAL	422, 444	PRDCN EXT	124	SSDCN EXT	140
C.-DSRN(RL) EXT	326	GFIL-R AXIAL	423, 445	PRSC(RL) EXT	125	SSKC(RL) EXT	141
C.-DSSN(RL) EXT	327	GFIR-L AXIAL	424, 446	PRSN(RL) EXT	296	SSSC(RL) INT	144
C.-DTFN(RL) INT	354	GFIR-R AXIAL	425, 447	PSBN(RL) EXT	318	STFC(RL) EXT	155
C.-DTJN(RL) EXT	351	GFK(RL) EXT	455	PSDNN EXT	320	STFC(RL) INT	158
C.-DVJN(RL) EXT	363	GFM(RL) EXT	439	PSKN(RL) EXT	321	STFC(RL)-A EXT	156
C.-DWLN(RL) EXT	381	GFML-L AXIAL	426, 448	PSKN(RL) INT	331	STFC(RL)-E INT	160
C.-DWLN(RL) INT	385	GFML-R AXIAL	427, 449	PSSN(RL) EXT	323	STJC(RL) EXT	157
C.-SCLC(RL) EXT	75	GFMR-L AXIAL	428, 450	PTFN(RL) EXT	348	SVAC(RL)-DC EXT	193
C.-SCLC(RL) INT	81	GFMR-R AXIAL	429, 450	PTFN(RL) INT	353	SVGC(RL) EXT	194
C.-SDJC(RL) EXT	96	GG.(RL) INT	421	PTGN(RL) EXT	349	SVHB(C)(RL) EXT	172, 195
C.-SDNCN EXT	97	GGI(RL)-90 AXIAL	430, 452	PTTN(RL) EXT	350	SVJB(C)(RL) EXT	173, 196
C.-SDUC(RL) INT	102	GLS B	414	PWLN(RL) EXT	380	SVJB(RL) INT	180, 204
C.-SRDCN EXT	130	GLSF(RL) EXT	410	PWLN(RL) INT	383	SVJC(RL)-DC EXT	197
C.-SVHB(RL) EXT	177, 201	GLSF(RL) EXT-G	412	S		SVLC(RL) INT	205
C.-SVJB(RL) EXT	178, 202	GLSF(RL) EXT-S	413	SCAC(RL) EXT	70	SVPB(C)(RL) EXT	174, 198
C.-SVQB(RL) INT	183, 210	K		SCBC(RL) EXT	71	SVQB(C)(RL) INT	181, 206
C.-SVVBN EXT	179, 203	KHP-CBN(RL)	251	SCDCR EXT	72	SVUB(C)(RL) INT	182, 207
CKJN(RL) EXT	287	KHP-CLN(RL)	252	SCFC(RL) EXT	73	SVVB(C)N EXT	175, 199
D		KHP-LBN(RL)	291	SCFC(RL) INT	76	SVXC(C)(RL) EXT	176, 200
DCBN(RL) EXT	240	KHP-RSC(RL)	131	SCKC(RL) INT	77	SVXC(RL) INT	208
DCKN(RL) EXT	242	KHP-SBN(RL)	328	SCLC(RL) EXT	74	SVXC(RL)-E INT	209
DCLN(RL) EXT	243	KHP-SSN(RL)	329	SCLC(RL) INT	78	SWLC(RL) EXT	215
DCLN(RL) INT	254	KHS-SBC(RL)	142	SCXC(RL) INT	80	SWLC(RL) INT	216
DDJN(RL) EXT	273	M		SDJC(RL) EXT	94	SWUC(RL) INT	217
DDUN(RL) INT	280	MS-EN	443, 463	SDNCN EXT	95	SWUC(RL)-E INT	218
DKH(RL)	132, 143, 253, 292, 330	MTJN(RL) EXT	347	SDQC(RL) INT	98	X	
DRSN(RL) EXT	295	MVJN(RL) EXT	362	SDUC(RL) INT	99	XLCCN 25 BS	442
DSBN(RL) EXT	313	MWLN(RL) EXT	379	SDUC(RL)-E INT	100	XLCCN B	440
DSDNN EXT	315	P		SDZC(RL) INT	101	XLCF(NRL) BS	461
DSKN(RL) EXT	316	P61(RL) EXT	470	SE(RL)	478, 522	XLCF(RL)	465
DSSN(RL) EXT	317	P61(RL) INT	471	SE(RL)-S	523	XLCFN B	459
DTFN(RL) EXT	345	P61S(RL)-1 INT	474	SEGC(RL) EXT	107	XLCFN B LFUX	466
DTFN(RL) INT	352	PCBN(RL) EXT	245	SELP(RL) INT	111	XLXFL BS AXIAL	462
		PCKN(RL) EXT	246	SELP(RL)-E INT	112		
				SEUC(RL) INT	108		



ÜRÜN GRUBU		ÜRÜN GRUBU		ÜRÜN GRUBU		ÜRÜN GRUBU	
C		KNUX	284	SPGN CER	147	TN ZZ INT	477
CCGT	60	L		SPMR	146	TNGA CBN	344
CCGW CBN	69	LCMF 13 – CM	418	SPUN	146	TNGA CER	343
CCMT	62	LCMF 13 – F	418	T		TNGN CER	344
CCMW	68	LCMF 13 – MP	419	TCGT	149	TNMA	334
CNGA CBN	239	LCMF 16 – CM	431	TCGW CBN	154	TNMG	335
CNGA CER	238	LCMF 16 – M	433	TCMT	150	TNMM	342
CNGG	222	LCMF 16, LCMF 30 – F	432	TCMW	154	TPGN CER	164
CNGN CER	238	LCMF 16, LCMF 30 – MP	433	TN 55° PP EXT	508	TPGX	162
CNMA	222	LCMF 20 – F1	453	TN 55° PP INT	509	TPMR	163
CNMG	223	LCMF 20 – M2	453	TN 60° PP EXT	499	TPUN	164
CNMM	234	LCMF 20 – MP	454	TN 60° PP INT	500	V	
CPGX	83	LCMR 13 – F	419	TN 60°-S PP EXT	501	VBGW CBN	171
D		LCMR 13 – MP	420	TN 60°-S PP INT	501	VBMT	168
DCGT	86	LCMR 16 – CM	434	TN ACME EXT	515	VCGT	186
DCGW CBN	92	LCMR 16 – M	435	TN ACME INT	516	VCGW	189
DCMT	87	LCMR 16 – MP	436	TN API RD EXT	519	VCGX	189
DCMW	92	LCMR 16, LCMR 30 – F	435	TN API RD INT	519	VCMT	190
DCMW PCD	93	LFMX – F1	456	TN BSPT EXT	510	VCMW	191
DNGA CBN	272	LFMX – F2	456	TN BSPT INT	510	VCMW PCD	192
DNGA CER	271	LFMX – M2	457	TN M EXT	495	VNGA CBN	359
DNGN CER	271	LFUX	464	TN M INT	497	VNGA CER	359
DNMA	260	LNUX 40, LN.X 50	289	TN MJ EXT	499	VNMG	356
DNMG	260	R		TN NPT EXT	511	W	
DNMM	270	RCGT	118	TN NPT INT	512	WCGT	212
E		RCGX CER	123	TN R EXT	475	WCGX	213
ECGT	104	RCMT	118	TN R INT	475	WCMT	213
ECMT	105	RCMW	120	TN RD EXT	520	WNGA CBN	376
ECMW	106	RCMX	121	TN RD INT	520	WNMA	366
EPGX	110	RNGN CER	294	TN STACME EXT	517	WNMG	366
EPMT	110	RNMG	294	TN STACME INT	518	WNMM	375
G		S		TN TR EXT	512	X	
GL. D – GM	406	SCGT	134	TN TR INT	513	X 61	468
GL. D – MM	406	SCMT	135	TN TR-S EXT	514	X 61 R	469
GL. D – PM	407	SCMW	138	TN TR-S INT	514	X 61 R-1	473
GL. D – PR	408	SNGA CER	311	TN UN EXT	502	X 61-1	472
H		SNGN CER	312	TN UN INT	503		
HZ	531	SNMA	300	TN UNJ EXT	504		
HZ-2	532	SNMG	301	TN W EXT	505		
K		SNMM	307	TN W INT	506		
		SNMX	311	TN ZZ EXT	476		



DORMER PRAMET



HIZLI ARAMA

Kütüphane uygulamamız üzerinden Dormer Pramet'in yakın zamanda sunduğu yayınlar arasında kolay ve hızlı bir şekilde metin araması gerçekleştirin. İlgili uygulama mağazanızdan bugün indirin.
Açıkça Güvenilir.

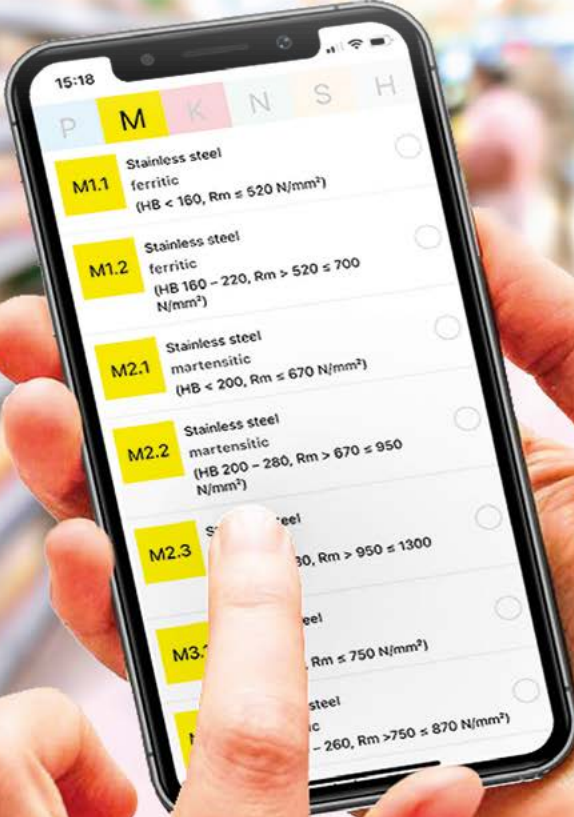



6		İŞ PARÇASI MALZEME GRUPLARI (WMG) VE ISO 13399
10	ISO TORNALAMA	GENEL BİLGİLER
18		REHBER
57		POZİTİF KESİCİ UÇLAR
219		NEGATİF KESİCİ UÇLAR
386		KESME VE KANAL AÇMA
482		DİŞ TORNALAMA
528		BROŞLAMA
536		GENEL TEKNİK BİLGİLER



İŞ PARÇASI MALZEME GRUPLARI (WMG)

ISO

Uygun kesme geometrisi ve takım kalitesi seçmek için iş parçası malzemesi grubu

Genel tanım

ör. çelik, paslanmaz çelik...

P M K N S H

Alt grup

Takım seçerken daha detaylı sınıflandırma için

Tanım yapıya/bileşime göre

ör. yalın karbon çeliği, alaşımlı çelik...

P M K N S H

P1

P2

P3

P4

WMG

±%10 doğrulukla kesme şartlarını seçmek için

Tanım

sertliğe/maksimum gerilme dayanımına göre

ör. 160 < 220HB, 620 < 900 n/mm² ...

P

P1

P2

P3

P4

P1.1 P1.2 P1.3

P2.1 P2.2 P2.3

P3.1 P3.2 P3.3

P4.1 P4.2 P4.3

DORMER PRAMET'İN İŞ PARÇASI MALZEMELERİ SINIFLANDIRMASI HAKKINDA

İş parçası malzeme grupları ("WMG"), belirli uygulamalardaki işleme koşulları için doğru kesici takımın ve başlangıç değerlerinin kolay ve güvenilir şekilde seçimini desteklemek için kullanılır.

Dormer Pramet iş parçası malzemelerini altı farklı renk grubunda sınıflandırır;

- **Mavi:** Çelik ve dökme çelikler (P grubu)
- **Sarı:** Paslanmaz çelik (M grubu)
- **Kırmızı:** Dökme demir (K grubu)
- **Yeşil:** Demir dışı metaller (N grubu)
- **Kahverengi:** Süper alaşımlar (S grubu)
- **Gri:** Sertleştirilmiş malzemeler (H grubu)

Bunların her biri, yapılarına ve/veya bileşimlerine göre alt gruplara ayrılır. Örneğin, P grubu çelik ve dökme çelik dört alt gruba ayrılır, yani;

- P1 – **Otomat çeliği**
- P2 – **Yalın karbon çeliği**
- P3 – **Alaşımlı çelik**
- P4 – **Takım çeliği**

Son bölüm, sertlik ve maksimum gerilme dayanımı gibi malzeme özelliklerini içerir. Bunun amacı müşterilerimize kesme hızı ve ilerleme için başlangıç değerleri de dahil komple bir takım önerisi sağlamaktır.

Bir sonraki sayfada yer alan tabloda, her bir iş parçası malzeme grubunun tanımı ve sık kullanılan işaretleme örnekleri bulunmaktadır



WMG (İŞ PARÇASI MALZEME GRUPLARI)

ISO grup	WMG (İş Parçası Malzeme Grupları)	Sertlik (HB veya HRC)	Toplam Gerilme Dayanımı (MPa)	Examples		
P	P1.1	Sülfürlü	< 240 HB	≤ 830		
	P1.2	Kolay işlenebilir çelik	< 180 HB	≤ 620		
	P1.3	(İşlenebilirliği artırılmış karbon çeliği)	< 180 HB	≤ 620		
	P2.1	Yalın karbon çeliği	< 180 HB	≤ 620		
	P2.2	(demir ve karbon ağırlıklı çelik)	İçerik < 0.25 % C	< 240 HB		≤ 830
	P2.3		İçerik < 0.55 % C	< 300 HB		≤ 1030
	P3.1	Alaşımli çelik	Tavlanmış	< 180 HB		≤ 620
	P3.2	(karbonlu çelik, alaşım ≤ %10)	Sertleştirilmiş ve tavlanmış	180 – 260 HB		> 620 ≤ 900
	P3.3			260 – 360 HB		> 900 ≤ 1240
	P4.1	Takım çeliği	Tavlanmış	< 26 HRC		≤ 900
P4.2	(kalıp için özel alaşımli çelikler)	Sertleştirilmiş ve tavlanmış	26 – 39 HRC	> 900 ≤ 1240		
P4.3			39 – 45 HRC	> 1240 ≤ 1450		
M	M1.1	Ferritik paslanmaz çelik	< 160 HB	≤ 520		
	M1.2	(sertleştirilemeyen düz krom alaşımı)	160 – 220 HB	> 520 ≤ 700		
	M2.1	Martensitik paslanmaz çelik	Tavlanmış	< 200 HB		≤ 670
	M2.2	(sertleştirilebilir düz krom alaşımı)	Sertleştirilmiş ve tavlanmış	200 – 280 HB		> 670 ≤ 950
	M2.3		Yaş sertleştirme	280 – 380 HB		> 950 ≤ 1300
	M3.1	Östenitik paslanmaz çelik	< 200 HB	≤ 750		
	M3.2	(krom nikel ve krom nikel manganlı alaşımlar)	200 – 260 HB	> 750 ≤ 870		
	M3.3		260 – 300 HB	> 870 ≤ 1040		
	M4.1	Östenitik ferritik (DUPEX) veya süper östenitik paslanmaz çelik	< 300 HB	≤ 990		
	M4.2	Yaş sertleştirilmiş östenitik paslanmaz çelik	300 – 380 HB	≤ 1320		
K	K1.1	Ferritik veya ferritik perlitik	< 180 HB	≤ 190		
	K1.2	Pik döküm (ASTM A48) veya Otomotiv Pik döküm (ASTM A159)	180 – 240 HB	> 190 ≤ 310		
	K1.3	(lamelli grafit mikroyapılı sahip demir karbon dökümü)	Perlitik	240 – 280 HB		> 310 ≤ 390
	K2.1	Dövülebilir demir (ASTM A602)	Ferritik	< 160 HB		≤ 400
	K2.2	(graftsız mikroyapılı demir karbon dökümü)	Ferritik veya perlitik	160 – 200 HB		> 400 ≤ 550
	K2.3		Perlitik	200 – 240 HB		> 550 ≤ 660
	K3.1	Sfero döküm (ASTM A536)	Ferritik	< 180 HB		≤ 560
	K3.2	(sfero grafit mikroyapılı demir karbon dökümü)	Ferritik veya perlitik	180 – 220 HB		> 560 ≤ 680
	K3.3		Perlitik	220 – 260 HB		> 680 ≤ 800
	K4.1	Östenitik pik döküm (ASTM A436)	< 180 HB	≤ 190		
K4.2	(östenitik lamelli grafit mikroyapılı demir-karbon alaşımli döküm)	< 240 HB	≤ 740			
K4.3	Östemperlenmiş pik döküm (ASTM A897)	< 280 HB	> 840 ≤ 980			
K4.4	(ösferrit mikroyapılı demir karbon alaşımli döküm)	280 – 320 HB	> 980 ≤ 1130			
K4.5		320 – 360 HB	> 1130 ≤ 1280			
K5.1	Sıkıştırılmış grafit demir CGI (ASTM A842)	Ferritik	< 180 HB	≤ 400		
K5.2	(kırımlı grafit yapıli demir karbon dökümü)	Ferritik-perlitik	180 – 220 HB	> 400 ≤ 450		
K5.3		Perlitik	220 – 260 HB	> 450 ≤ 500		
N	N1.1	Saf dövme alüminyum	< 60 HB	≤ 240		
	N1.2	Dövme alüminyum alaşımları	Yarı sert tavlanmış	60 – 100 HB		> 240 ≤ 400
	N1.3		Tam sert tavlanmış	100 – 150 HB		> 400 ≤ 590
	N2.1		< 75 HB	≤ 240		
	N2.2	Döküm alüminyum alaşımları	75 – 90 HB	> 240 ≤ 270		
	N2.3		90 – 140 HB	> 270 ≤ 440		
	N3.1	Kolay işlenebilir bakır alaşımları	–	–		
	N3.2	Orta zorlukta işlenebilir, kısa talaş veren bakır alaşımları	–	–		
	N3.3	Zor işlenebilir, uzun talaş veren bakır alaşımları	–	–		
	N4.1	Termoplastik polimerler	–	–		
N4.2	Termoset polimerler	–	–			
N4.3	Camelyaf polimer veya kompozitler	–	–			
N5.1	Grafit	–	–			
S	S1.1		< 200 HB	≤ 660		
	S1.2	Titanyum ya da titanyum alaşımları	200 – 280 HB	> 660 ≤ 950		
	S1.3		280 – 360 HB	> 950 ≤ 1200		
	S2.1		< 200 HB	≤ 690		
	S2.2	Fe-bazlı sıcak iş alaşımları	200 – 280 HB	> 690 ≤ 970		
	S3.1		< 280 HB	≤ 940		
	S3.2	Ni-bazlı sıcak iş alaşımları	280 – 360 HB	> 940 ≤ 1200		
	S4.1		< 240 HB	≤ 800		
	S4.2	Co-bazlı sıcak iş alaşımları	240 – 320 HB	> 800 ≤ 1070		
	H	H1.1	Soğutulmuş dökme demir	< 440 HB		–
H2.1			< 55 HRC	–		
H2.2		Sertleştirilmiş dökme demir	> 55 HRC	–		
H3.1			< 51 HRC	–		
H3.2		Sertleştirilmiş çelik < 55 HRC	51 – 55 HRC	–		
H4.1			55 – 59 HRC	–		
H4.2		Sertleştirilmiş çelik > 55 HRC	> 59 HRC	–		

İşleme malzemelerine örnekler – bkz. bölüm GENEL TEKNİK BİLGİLER (sayfa 539).



ISO 13399'A GÖRE KESİCİ TAKIM PARAMETRELERİ

Tüm kesici takımlar ISO 13399 standardına göre çeşitli parametreler ile tanımlanır. Bu listede, bu katalogta kullanılan tüm parametreler ve bunların tanımları yer alır.

ISO 13399, uluslararası kesici takım bilgisi standardıdır. Belirli bir sistem veya şirket terminolojisinden bağımsız, nötr formatta boyutlar ve parametreler sağlar. Kesici takımlar global bir standarda göre net bir biçimde tanımlandığında, tüm yazılım türleri elektronik verileri daha hızlı bir şekilde işleyebilir, böylece iletişimin kalitesi artar ve bilgi alışverişinin sorunsuz çalışması sağlanır. Kesici takım açıklamalarımızda ortak bir dili destekleyerek sistem iletişimde bu sisteme yardımcı olur. 40.000 farklı yekpare ve değiştirilebilir takımımız ile yüksek kalitede verilerin daha kolay toplanmasını sağlayarak size önemli miktarda zaman tasarrufu sağlar. ISO 13399 uyumlu bir sistem kullandığınızda verileri manuel olarak yorumlamanız ve sisteminize girmeniz gerekmez.

SADECE NUMUNELER!

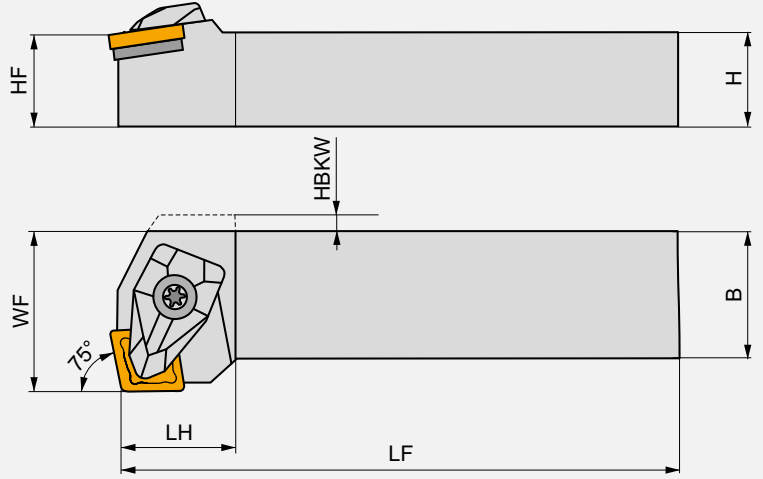
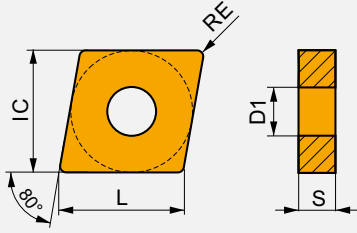

ISO 13399	Açıklama
APMX	Maksimum kesme derinliği
B	Şaft genişliği
BD	Gövde çapı
BLRAD	Kesici destekleme yarıçapı
BW	Kesici uç gövde genişliği
CDX	Maksimum kesme derinliği
CND	Kesme sıvısı giriş çapı
CUTDIA	İş parçası maksimum dilimleme yarıçapı
CW	Kesme genişliği
CWTOLL	Kesme genişliği alt toleransı
CWTOLU	Kesme genişliği üst toleransı
D1	Sabitleme deliği çapı
DAXIN	Minimum eksenel kanal iç çapı
DAXN	Minimum eksenel kanal dış çapı
DAXX	Maksimum eksenel kanal dış çapı
DCON MS	Bağlantı çapı
DMIN	Minimum delik yarıçapı
DMINP	Minimum dikey delik yarıçapı
GAMO	Dikey kesme Açısı
GAMP	Eksenel kesme açısı
H	Şaft yüksekliği
HBH	Baştan aşağı ofset yüksekliği
HBKW	Baştan aşağı ofset genişliği
HF	Fonksiyonel yükseklik
IC	İç teğet daire çapı
INSD	Kesici uç çapı
INSL	Kesici uç uzunluğu

ISO 13399	Açıklama
KAPR	Takım kesme kenarı açısı
L	Kesme kenarı uzunluğu
LAMS	Eğim açısı
LB	Gövde uzunluğu
LF	Fonksiyonel uzunluk
LFA	LF'deki A boyutu
LFS	İkincil fonksiyonel uzunluk
LH	Kafa uzunluğu
LU	Kullanılabilir uzunluk
M	M-ölçüsü
OAL	Toplam uzunluk
PDX	Profil mesafesi X
PDY	Profil mesafesi Y
PSIRL	Takım giriş açısı sol
PSIRR	Takım giriş açısı sağ
RE	Köşe yarıçapı
S	Kesici uç kalınlığı
S1	Toplam kesici uç kalınlığı
TP	Diş hatvesi
TPI	İnç başına dişler
TPIN	İnç başına dişler
TPIX	İnç başına dişler
TPN	Minimum diş hatvesi
TPX	Maksimum diş hatvesi
W1	Kesici uç genişliği
WF	Fonksiyonel genişlik
WFS	İkincil fonksiyonel genişlik



DORMER PRAMET



BÜTÜN TAKIMLAR BİR ARADA

Bütün dönen ve takma uçlu ürün ailemiz işleme hesaplayıcısının içinde. 40.000'den fazla ürün! Her ne işlerseniz mutlaka bir çözümümüz var. **Simply Reliable.**

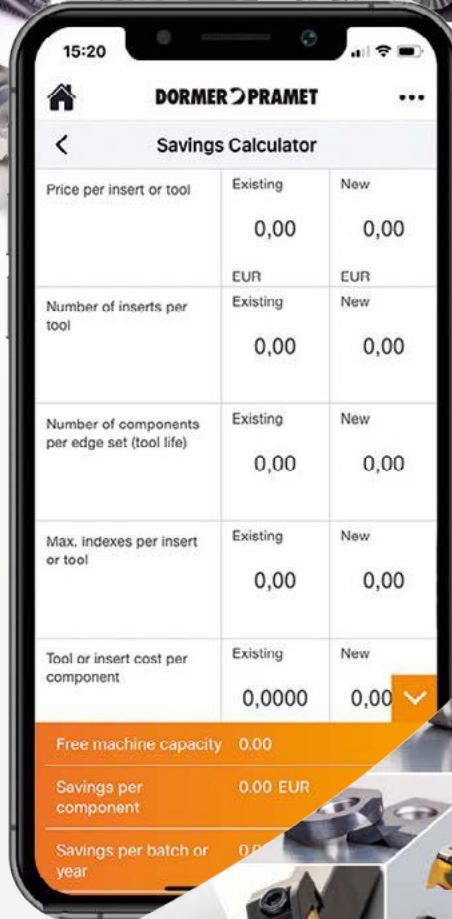

DORMER PRAMET		
Savings Calculator		
Price per insert or tool	Existing	New
	0,00	0,00
	EUR	EUR
Number of inserts per tool	Existing	New
	0,00	0,00
Number of components per edge set (tool life)	Existing	New
	0,00	0,00
Max. indexes per insert or tool	Existing	New
	0,00	0,00
Tool or insert cost per component	Existing	New
	0,0000	0,00
Free machine capacity	0,00	
Savings per component	0,00 EUR	
Savings per batch or year	0,00	

ISO TORNALAMA





TORNALAMA – GENEL İÇERİK

6

İŞ PARÇASI MALZEME GRUPLARI (WMG) VE ISO 13399

10

GENEL BİLGİLER

18

REHBER

57

POZİTİF KESİCİ UÇLAR

219

NEGATİF KESİCİ UÇLAR

ISO TORNALAMA

386

KESME VE KANAL AÇMA

482

DİŞ TORNALAMA

526

BROŞLAMA

533

TEKNİK BİLGİLER



TORNALAMA UÇLARI – GENEL BAKIŞ SAYFASI

PRAMET

1 CNMM

	IC	D1	L	S
	[mm]	[mm]	[mm]	[mm]
1204	12.700	5.16	12.90	4.76
1606	15.875	6.35	16.10	6.35
1906	19.050	7.94	19.30	6.35
2509	25.400	9.12	25.80	9.53

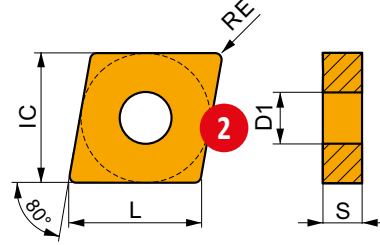

Kesme hızı (vc), ilerleme (f) ve kesme derinliği (ap) için uygunluk ve başlangıç değerleri. Daha ileri hesaplamalar için İşleme Hesaplayıcısı uygulamasına başvurun.

Product	RE	P			M			K			N			S			H		
		vc	f	ap	vc	f	ap	vc	f	ap	vc	f	ap	vc	f	ap			
	[mm]	[m/min]	[mm/rev]	[mm]	[m/min]	[mm/rev]	[mm]	[m/min]	[mm/rev]	[mm]	[m/min]	[mm/rev]	[mm]	[m/min]	[mm/rev]	[mm]			

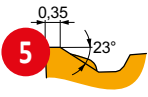

10 DR geometri, yarı kabadan kaba işleme, ve sürekliden aralıklı kesmeye kadar uygun.

CNMM 160612E-DR	T9315	1.2	225	0.45	6.0	–	–	–	210	0.45	6.0	–	–	–	–	–	–
	T9325	1.2	200	0.45	6.0	120	0.41	6.0	190	0.45	6.0	–	–	–	–	–	–
	T9335	1.2	170	0.45	6.0	100	0.41	6.0	–	–	–	–	–	–	–	–	–
CNMM 190608E-DR	T9315	0.8	215	0.40	8.0	–	–	–	200	0.40	8.0	–	–	–	–	–	–
	T9325	0.8	190	0.40	8.0	110	0.36	8.0	180	0.40	8.0	–	–	–	–	–	–
CNMM 190612E-DR	T9315	1.2	220	0.45	8.0	–	–	–	205	0.45	8.0	–	–	–	–	–	–
	T9325	1.2	195	0.45	8.0	115	0.41	8.0	185	0.45	8.0	–	–	–	–	–	–
	T9335	1.2	170	0.45	8.0	100	0.41	8.0	–	–	–	–	–	–	–	–	–
CNMM 190616E-DR	T9325	1.6	195	0.50	9.0	115	0.45	9.0	185	0.50	9.0	–	–	–	–	–	–
	T9335	1.6	170	0.50	9.0	100	0.45	9.0	–	–	–	–	–	–	–	–	–

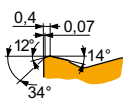

HR geometri, kapadan ağır kaba işleme kadar, darbesizden darbeli kesime kadar uygun.

CNMM 190616E-HR	6640	1.6	75	0.60	10.0	45	0.54	10.0	70	0.60	10.0	–	–	–	–	–	–
	T8345	1.6	55	0.60	10.0	30	0.54	10.0	50	0.60	10.0	–	–	–	–	–	–
	T9325	1.6	105	0.60	10.0	60	0.54	10.0	95	0.60	10.0	–	–	–	–	–	–
	T9335	1.6	80	0.60	10.0	45	0.54	10.0	–	–	–	–	–	–	–	–	–

CNMM190616E-HR:T8345

Sipariş verirken kesici uç özellik kodunu tam olarak belirtin!

Kalite

İki nokta üst üste işaretini ekleyin

ISO kesici uç kodu



TORNALAMA UÇLARI – GENEL BAKIŞ SAYFASI

Poz.	Açıklama	Poz.	Açıklama
1	Kesici ucun işareti	7	ISO kesici uç kodu
2	Kesici ucun şematik çizimi	8	Kalite
3	Kesici uç boyutları tablosu (mm)	9	Kesici uç yarıçapları (mm)
4	Temsili kesici ucun resmi	10	Geometri açıklaması
5	Ana Kesme kenarının profili	11	Kesici ucun uygulama alanı
6	Simgeler - spesifik özellikler ve kesme kenarı tipi		



TORNALAMA TUTUCULARI – GENEL BAKIŞ SAYFASI

1 DDUN(RL) INT



PRAMET 3

D



5 DN.. Uç için Çift Sıkmalı 93° Açılı Delik Kateri

Çift sıkmalı 93° Sağ/Sol içten su vermeli delik kateri. Negatif DN.. 11 veya 15 uçlarla minimum Ø32mm çap, birçok uygulama ve 27°'ye kadar kopya tornalama için uygundur. Ø25-50mm shaft ölçüleri. Gövde uzun takım ömrü için işlem görmüştür.

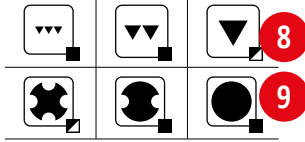
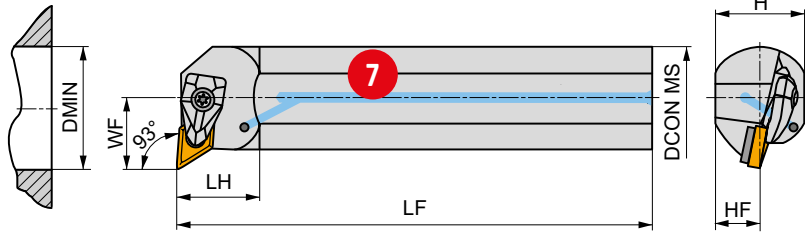
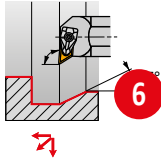

Product	DCON MS [mm]	DMIN [mm]	WF [mm]	H [mm]	HF [mm]	LF [mm]	LH [mm]	LAMS [°]	GAMO [°]					
A25T-DDUNR 11	25	32	17	23	11.5	300	28	-12	-6	✓	0.96	GI046	DD11	-
A32T-DDUNR 11	32	40	22	30	15	300	30	-10	-6	✓	1.68	GI046	DD11	-
A40T-DDUNR 15	40	50	27	37	18.5	300	36	-11	-6	✓	2.59	GI044	DD154	AT002
A50U-DDUNR 15	50	63	35	47	23.5	350	39	-8	-6	✓	5.25	GI044	DD154	AT002
A25T-DDUNL 11	25	32	17	23	11.5	300	28	-12	-6	✓	0.96	GI046	DD11	-
A32T-DDUNL 11	32	40	22	30	15	300	30	-10	-6	✓	1.69	GI046	DD11	-
A40T-DDUNL 15	40	50	27	37	18.5	300	36	-11	-6	✓	2.59	GI044	DD154	AT002
A50U-DDUNL 15	50	63	35	47	23.5	350	39	-8	-6	✓	5.25	GI044	DD154	AT002

	GI044	DN.. 1506..
	GI046	DN.. 1104..

	DD11	DCS 09	1.7	DDS 267-01	US 2004-T09P	FLAG T09P
	DD154	DCS 12	3.9	DDS 266-02	US 2002-T15P	FLAG T15P/3,5

	AT002a	DN.. 1504..	-	DDS 266-01
	AT002b	CER DN.N 1506..	-	DCS 12C4
	AT002c	CER DN.A 1506..	-	DCS 12C2



TORNALAMA TAKILARI – GENEL BAKIŞ SAYFASI

Poz.	Açıklama
1	Tornalama tutucusunun işareti
2	Malzeme grubu önerileri
3	Kesici ucun bağlama sistemi
4	Açıklayıcı resim ¹⁾
5	Takım açıklaması
6	İş parçası profili
7	Takımın şematik çizimi
8	Ulaşılabilir yüzey kalitesi
9	Kesim karakteri/çalışma koşulları
10	Ürün uygulamaları
11	Takım tasarımı

Poz.	Açıklama
12	ISO tutucu kodu
13	Tutucunun ölçüleri [mm] ve açıları ²⁾ [°]
14	İçten kesme sıvısı beslemesi
15	Ağırlık [kg]
16	Uyumlu kesici uç grubu ³⁾
17	Yedek parça grubu ^{3), 4)}
18	Aksesuarlar grubu ^{3), 4)}
19	Uyumlu kesici uçlar
20	Yedek parçalar
21	Özel aksesuarlar

¹⁾ Resimlerde birincil olarak sağ kesme yönlü (R) takım gösterilmiştir.

²⁾ GAMO = ortogonal açı (bkz. teknik bölüm)

LAMS = Ana kesici kenar eğim açısı (bkz. teknik bölüm)

³⁾ Uyumlu kesici uçlar, yedek parçalar ve özel aksesuarlar kodlama grubu sadece katalog amaçlıdır ve siparişler için kullanılamaz.

⁴⁾ Yedek parçaların ve özel aksesuarların sembolleri kolay anlaşılabilirliği için şematik olarak tasarlanmıştır. Bazı durumlarda vidalar Nm tork moment, vida boyu ve dış ölçüsü bilgileri ile tamamlanmıştır.



TORNALAMA TAKIMLARI – SİMGELERE GENEL BAKIŞ

GENEL SİMGELER

	Birincil kullanım		Finiş işleme – çok iyi yüzey kalitesi		Stabil çalışma koşullarına uygun
	Olası kullanım		Orta talaş işleme – iyi yüzey kalitesi		Stabil olmayan çalışma koşullarına uygun
			Kaba talaş işleme – sınırlanmamış yüzey pürüzlülüğü		Çok dengesiz çalışma koşullarına uygun

ÖZELLİKLER

	İlk tercih		Silici geometrisine sahip kesici uç		Keskin kenar
	Kısa talaş oluşturan malzemeler için		Büyük kullanma mesafesi		Yuvarlatılmış kenar
	Sert malzemeler için (uzun talaş oluşturan)		Demiryolu tekerlekleri işleme		Fazlı kenar
	Ağır çalışma koşulları		İnce duvarlı ve ince iş parçaları		Fazlı yuvarlatılmış kenar
	Yüksek ilerlemeli Kesim		Üniversal geniş aralık seçeneği		Çift fazlı kenar
	Yüksek hızlı kesim				Çift fazlı yuvarlatılmış kenar

TORNALAMA İŞLEMLERİ

	Koni tornalama – dıştan		Pah verme (kenar kırma)		Arka yüzü (omuz) arkadan işleme
	Koni tornalama – içten		Arkadan pah verme (kenar kırma)		Çok yönlü kopya tornalama – dıştan
	Kopya tornalama (çok yönlü işleme)		Delik içinde pah verme (kenar kırma)		Çok yönlü kopya tornalama – içten
	Alın kopya tornalama		Omuz ile boyuna tornalama - dıştan		Tek yönlü kopya tornalama – dıştan
	Delik içinde alın kopya tornalama		Omuz ile boyuna tornalama - içten		Tek yönlü kopya tornalama – içten
	Omuzlu alın tornalama		Omuz olmadan boyuna tornalama - dıştan		Sığ radyal oluk
	Omuzsuz alın tornalama		Omuz olmadan boyuna tornalama - içten		



TORNALAMA TAKIMLARI – SİMGELERE GENEL BAKIŞ

TEKNİK SAYFALAR





























	Hassas finiş		İlerleme [mm/dev]		Çok yüksek kesme hızı, mükemmel sistem rijitliği (rijit işleme şartları)
	Finiş		Dayanıklılık [dk]		Yüksek kesme hızı, yüksek sistem rijitliği (rijit işleme şartları)
	Orta		Kalite		Yüksek kesme hızı, sistem rijitliği hafifçe sınırlı (paso değişkenliği)
	Kaba		Kaplama		Orta kesme hızı, sistem rijitliği sınırlı (hafif darbeli kesim)
	Ağır kaba		Kesme hızı		Düşük kesme hızı, düşük sistem rijitliği (darbeli kesim)
	Multiplication factor for cutting speed		Kesme kenar profili		Çok düşük kesme hızı, çok düşük sistem rijitliği (Rijit olmayan işleme koşulları)
	Kesme derinliği [mm]		Soğutma		

DİĞERLERİ

	Vidanın bağlama torku [Nm]		Kaba işleme için kafa grubu		İçten kesme sıvısı beslemesi
---	----------------------------	---	-----------------------------	---	------------------------------



ISO KESİCİ UÇLAR POZİTİF – REHBER

CCGT  60	CCMT  62	CCMW  68	CCGW CBN  69	
DCGT  86	DCMT  87	DCMW  92	DCGW CBN  92	DCMW PCD  93
ECGT  104	ECMT  105	ECMW  106	EPGX  110	EPMT  110
RCGT  118	RCMT  118	RCMW  120	RCMX  121	RCGX CER  123
SCGT  134	SCMT  135	SCMW  138	SPMR  146	SPUN  146
SPGN CER  147				
TCGT  149	TCMT  150	TCMW  154	TCGW CBN  154	

TPGX



162

TPMR



163

TPUN



164

TPGN CER



164

VBMT



168

VBGW CBN



171

VCGT



186

VCGW



189

VCGX



189

VCMT



190

VCMW



191

VCMW PCD



192

WCGT



212

WCGX



213

WCMT



213



ISO KESİCİ UÇLAR NEGATİF – REHBER

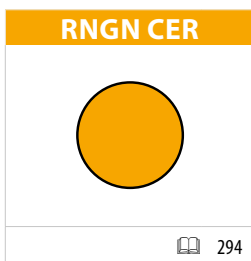
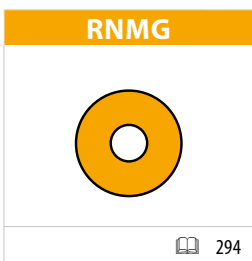
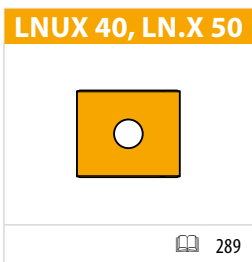
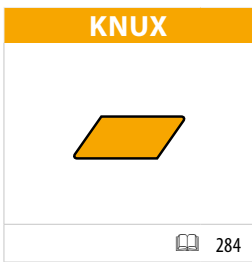
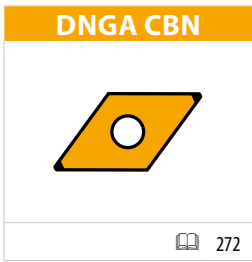
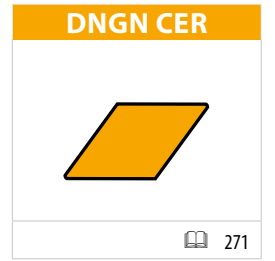
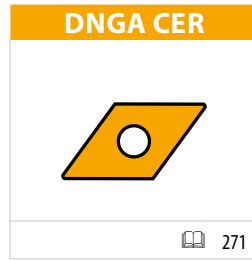
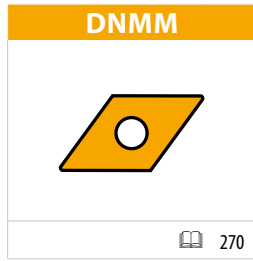
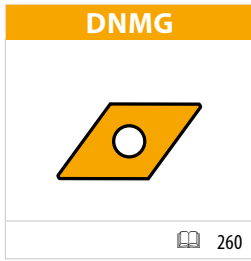
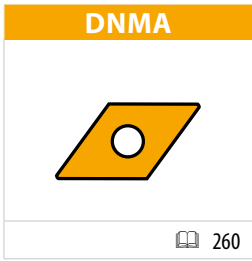
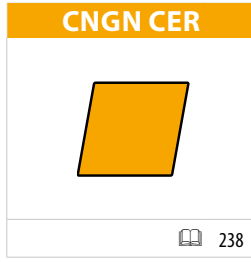
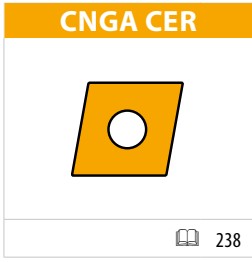
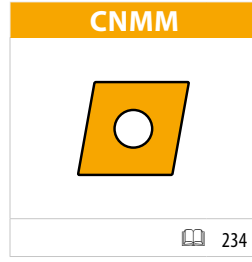
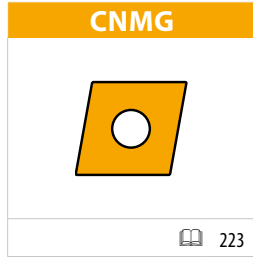
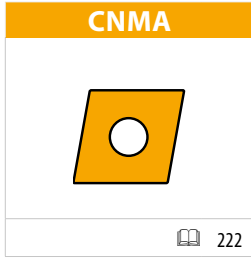

SNMA



300

SNMG



301

SNMM



307

SNMX



311

SNGA CER



311

SNGN CER

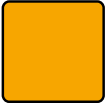

312

TNMA



334

TNMG



335

TNMM



342

TNGA CER



343

TNGN CER



344

TNGA CBN



344

VNMG



356

VNGA CER



359

VNGA CBN



359

WNMA



366

WNMG



366

WNMM



375

WNGA CBN



376

P



Rijit olmayan işleme koşulları





Biraz daha kötü işleme koşulları



Rijit işleme koşulları



İnce cidarlı ve zayıf iş parçaları

 1. Tercih
 Olası kullanım



RF



SR



FF2



FM2



RM3



FF

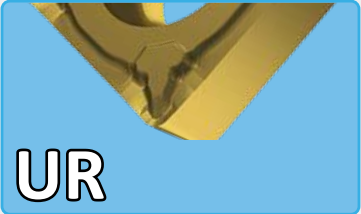

UR



FM



RM

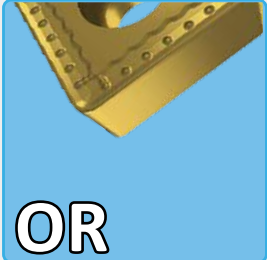



OR





SF3

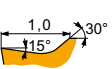

DR4

	FF	F	M	R	HR
	0.05 – 0.2 mm/dev	0.05 – 0.2 mm/dev	0.2 – 0.4 mm/dev	0.4 – 1.0 mm/dev	> 1.0 mm/dev
	0.05 – 2 mm	0.05 – 2 mm	2 – 4 mm	4 – 10 mm	> 10 mm

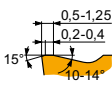
UR		İnce talaşlı ve yüzey işleme, çelikler ve dökme demirler ve potansiyel olarak paslanmaz çelik, sürekli ve darbeli kesimler için tasarlanmıştır
FM		İnce talaşlı ve yarı kaba işleme, çelikler ve paslanmaz çelikler, potansiyel olarak dökme demirler ve demir içermeyen malzemeler, sürekli ve orta darbeli kesimler için tasarlanmıştır
RM		Yarı kaba işleme, çelikler, paslanmaz çelikler ve dökme demirler, potansiyel olarak süper alaşımlar ve sertleştirilmiş malzemeler, sürekli ve darbeli kesimler için tasarlanmıştır
OR		Kaba ve ağır kaba işleme, çelikler, paslanmaz çelikler ve dökme demirler, potansiyel olarak süper alaşımlar, sürekli ve darbeli kesimler için tasarlanmıştır

M

 Rijit olmayan işleme koşulları

 Biraz daha kötü işleme koşulları

 Rijit işleme koşulları

 İnce cidarlı ve zayıf iş parçaları

 1. Tercih
  Olası kullanım



NF1



FM2



RF



SR

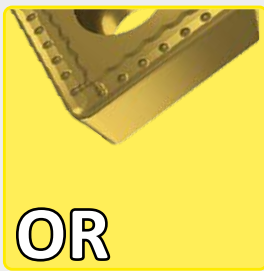

OR



SF2



NF2



FM



RM



DR4



SF3



SI

0.05 – 0.2 mm/dev

0.05 – 0.2 mm/dev

0.2 – 0.4 mm/dev

0.4 – 1.0 mm/dev

> 1.0 mm/dev

0.05 – 2 mm

0.05 – 2 mm

2 – 4 mm

4 – 10 mm

> 10 mm

NF1		İnce finiş işlemeden orta işleme, paslanmaz çelikler ve süper alaşımlar, potansiyel olarak çelikler, demir içermeyen ve sert malzemelerde sürekli kesimler için pozitif tasarım
FM		İnce talaşlı ve yarı kaba işleme, çelikler ve paslanmaz çelikler, potansiyel olarak dökme demirler ve demir içermeyen malzemeler, sürekli ve orta darbeleri kesimler için tasarlanmıştır
RM		Yarı kaba işleme, çelikler, paslanmaz çelikler ve dökme demirler, potansiyel olarak süper alaşımlar ve sertleştirilmiş malzemeler, sürekli ve darbeleri kesimler için tasarlanmıştır

OR		Kaba ve ağır kaba işleme, çelikler, paslanmaz çelikler ve dökme demirler, potansiyel olarak süper alaşımlar, sürekli ve darbeleri kesimler için tasarlanmıştır
-----------	--	--

23





ISO KESİCİ UÇLAR POZİTİF – TALAŞ KIRICI REHBERİ

K

 Rijit olmayan işleme koşulları

 Biraz daha kötü işleme koşulları

 Rijit işleme koşulları

 İnce cidarlı ve zayıf iş parçaları

 1. Tercih

 Olası kullanım

RM3

.CMW

RF

RM

SR

OR

DR4

SF3



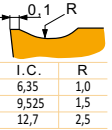
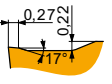
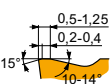

	0.05 – 0.2 mm/dev	0.05 – 0.2 mm/dev	0.2 – 0.4 mm/dev	0.4 – 1.0 mm/dev	> 1.0 mm/dev
	0.05 – 2 mm	0.05 – 2 mm	2 – 4 mm	4 – 10 mm	> 10 mm

RF	 <table><tr><td>0.1 R</td></tr><tr><td>I. C.</td><td>R</td></tr><tr><td>6,35</td><td>1,0</td></tr><tr><td>9,525</td><td>1,5</td></tr><tr><td>12,7</td><td>2,5</td></tr></table>	0.1 R	I. C.	R	6,35	1,0	9,525	1,5	12,7	2,5	Kaba işleme, dökme demirler, potansiyel olarak çelikler paslanmaz çelikler ve sert malzemeler, sürekli ve darbeli kesimler için tasarlanmıştır
0.1 R											
I. C.	R										
6,35	1,0										
9,525	1,5										
12,7	2,5										
RM	 <table><tr><td>0.27 R</td></tr><tr><td>717°</td></tr></table>	0.27 R	717°	Yarı kaba işleme, çelikler, paslanmaz çelikler ve dökme demirler, potansiyel olarak süper alaşımlar ve sertleştirilmiş malzemeler, sürekli ve darbeli kesimler için tasarlanmıştır							
0.27 R											
717°											
OR	 <table><tr><td>0.5-1.25</td></tr><tr><td>0.2-0.4</td></tr><tr><td>15°</td></tr><tr><td>10-14</td></tr></table>	0.5-1.25	0.2-0.4	15°	10-14	Kaba ve ağır kaba işleme, çelikler, paslanmaz çelikler ve dökme demirler, potansiyel olarak süper alaşımlar, sürekli ve darbeli kesimler için tasarlanmıştır					
0.5-1.25											
0.2-0.4											
15°											
10-14											

N

 Rijit olmayan işleme koşulları

 Biraz daha kötü işleme koşulları

 Rijit işleme koşulları

 İnce cidarlı ve zayıf iş parçaları

 1. Tercih

 Olası kullanım

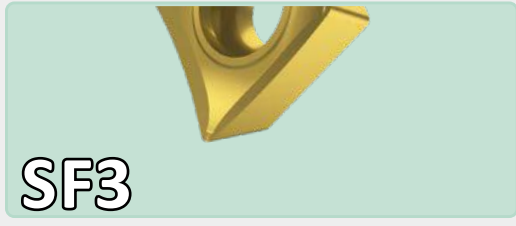

SF3



NF1



FM

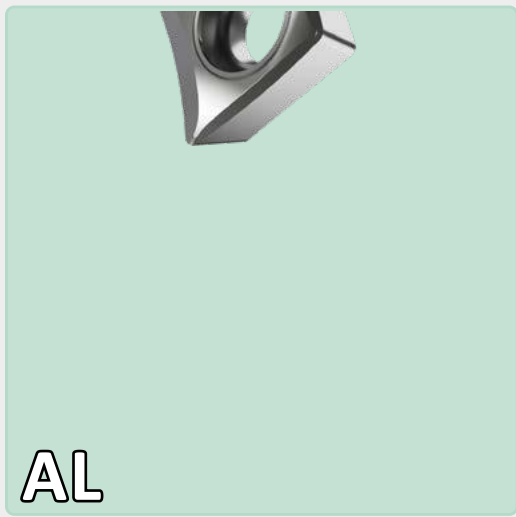

AL



0.05 – 0.2 mm/dev

0.05 – 0.2 mm/dev

0.2 – 0.4 mm/dev

0.4 – 1.0 mm/dev

> 1.0 mm/dev



0.05 – 2 mm

0.05 – 2 mm

2 – 4 mm

4 – 10 mm

> 10 mm

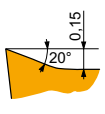
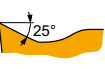
SF3		<p>İnce ve finiş işleme, süper alaşımlar, paslanmaz çelikler ve demir içermeyen malzemeler, potansiyel olarak çelikler, dökme demirler ve sert malzemelerde sürekli kesimler için çok pozitif tasarım</p>			
AL		<p>İnce finiş işlemeden kaba işlemeye, alüminyum alaşımları ve diğer demir içermeyen malzemeler, potansiyel olarak süper alaşımlar, sürekli kesimler için yüksek ölçüde pozitif tasarım</p>			





ISO KESİCİ UÇLAR POZİTİF – TALAŞ KIRICI REHBERİ

S

 Rijit olmayan işleme koşulları

 Biraz daha kötü işleme koşulları

 Rijit işleme koşulları

 İnce cidarlı ve zayıf iş parçaları



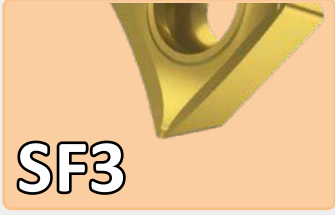

 SF2



 SF3

 NF1

 NF2

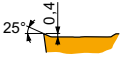
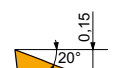

	0.05 – 0.2 mm/dev	0.05 – 0.2 mm/dev	0.2 – 0.4 mm/dev	0.4 – 1.0 mm/dev	> 1.0 mm/dev
	0.05 – 2 mm	0.05 – 2 mm	2 – 4 mm	4 – 10 mm	> 10 mm

SF2		İnce ve finiş işleme, süper alaşımlar, potansiyel olarak paslanmaz çelikler, çelikler ve demir içermeyen malzemelerde sürekli kesimler için çok pozitif tasarım			
SF3		İnce ve finiş işleme, süper alaşımlar, paslanmaz çelikler ve demir içermeyen malzemeler, potansiyel olarak çelikler, dökme demirler ve sert malzemelerde sürekli kesimler için çok pozitif tasarım			
NF2		İnce finiş işlemeden yarı kaba işlemeye, paslanmaz çelikler ve süper alaşımlar, sürekli kesim için pozitif tasarım			

H



1. Tercih

Olası kullanım



RM3



NF1

.CMW



SF3

	FF	F	M	R	HR
f	0.05 – 0.2 mm/dev	0.05 – 0.2 mm/dev	0.2 – 0.4 mm/dev	0.4 – 1.0 mm/dev	> 1.0 mm/dev
a_p	0.05 – 2 mm	0.05 – 2 mm	2 – 4 mm	4 – 10 mm	> 10 mm

SF3		İnce ve finiş işleme, süper alaşımlar, paslanmaz çelikler ve demir içermeyen malzemeler, potansiyel olarak çelikler, dökme demirler ve sert malzemelerde sürekli kesimler için çok pozitif tasarım
NF1		İnce finiş işlemeden orta işlemeye, paslanmaz çelikler ve süper alaşımlar, potansiyel olarak çelikler, demir içermeyen ve sert malzemelerde sürekli kesimler için pozitif tasarım
.CMW		İnce finiş işlemeden yarı kaba işlemeye, dökme demirler, potansiyel olarak sert malzemeler, sürekli ve hafif darbeli kesimler için tasarlanmıştır
RM3		Kaba işleme, dökme demirler, potansiyel olarak çelikler paslanmaz çelikler ve sert malzemeler, sürekli ve darbeli kesimler için tasarlanmıştır



ISO KESİCİ UÇLAR NEGATİF – TALAŞ KIRICI REHBERİ

P

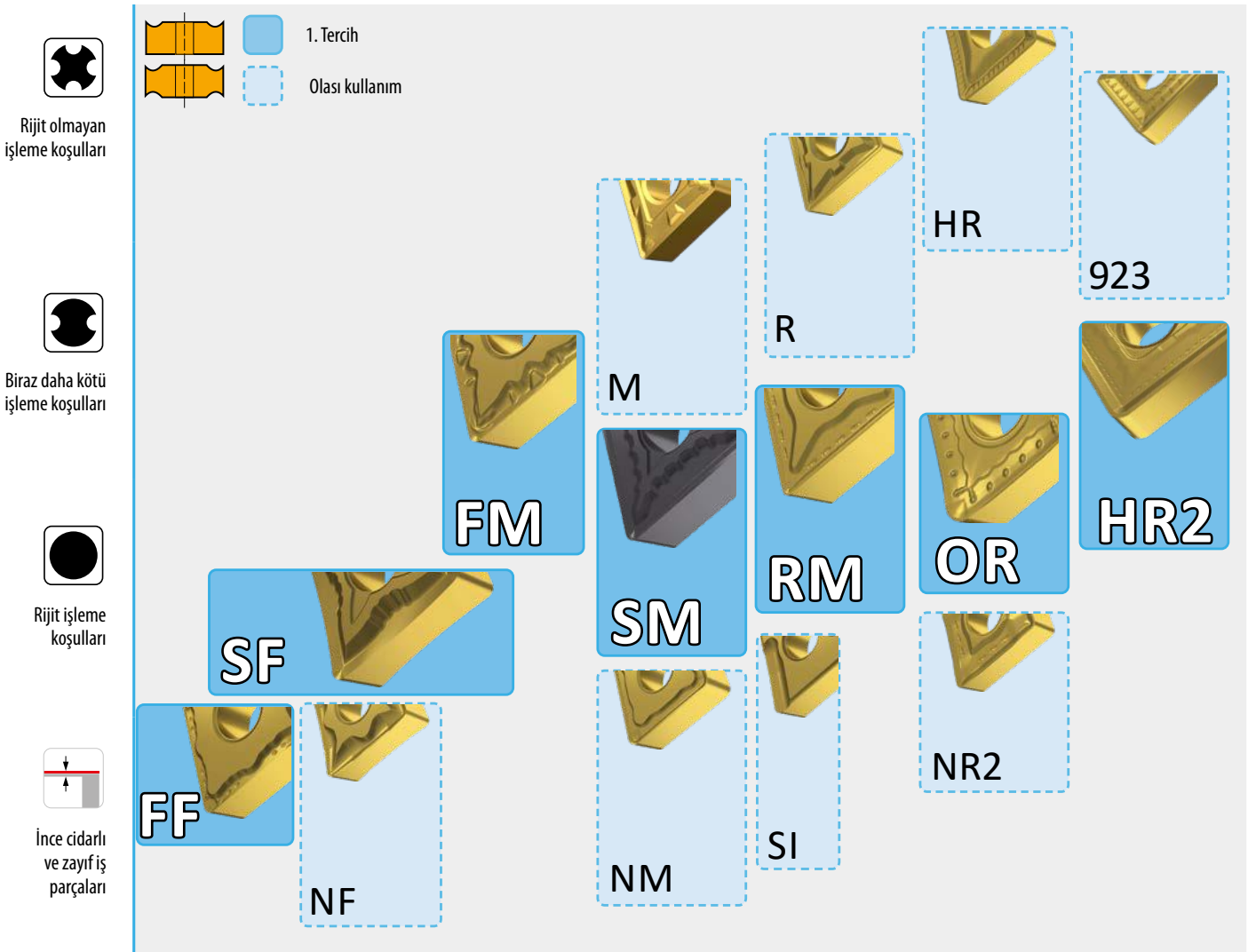

	FF	F	M	R	HR
	0.05 – 0.2 mm/dev	0.05 – 0.2 mm/dev	0.2 – 0.4 mm/dev	0.4 – 1.0 mm/dev	> 1.0 mm/dev
	0.05 – 2 mm	0.05 – 2 mm	2 – 4 mm	4 – 10 mm	> 10 mm

FF		İnce ve finiş işleme, paslanmaz çelik ve çelik, potansiyel olarak dökme demirler ve sürekli kesim için tasarlanmış yüksek düzeyde pozitif geometri
SF		İnce finiş işleme, çelikler, paslanmaz çelikler, dökme demirler, süper alaşımlar ve sert malzemeler, potansiyel olarak demir içermeyen malzemeler ve ince duvarların sürekli kesimli işlenmesi için tasarlanmış çok yönlü pozitif geometri
FM		Finiş işlemeden yarı kaba işlemeye, çelik ve dökme demirler, potansiyel olarak süper alaşımlar, sürekli ve orta derecede darbeleri kesimler için tasarlanmış pozitif geometri

SM		Orta işleme, paslanmaz çelikler, süper alaşımlar, çelikler ve dökme demirler, potansiyel olarak demir içermeyen ve sert malzemeler ve ince duvarları, sürekli ve darbeleri kesimlerle işlemek için tasarlanmış pozitif geometri
RM		Yarı kaba ve kaba işleme, çelikler, paslanmaz çelikler ve dökme demirler, potansiyel olarak süper alaşımlar, sürekli ve darbeleri kesimler için tasarlanmıştır
OR		Finiş işlemeden ağır kaba işlemeye, çelikler ve dökme demirler, potansiyel olarak paslanmaz çelik ve süper alaşımlar, sürekli ve darbeleri kesimler için tasarlanmıştır

M

Rijit olmayan işleme koşulları

Biraz daha kötü işleme koşulları

Rijit işleme koşulları

İnce cidarlı ve zayıf iş parçaları

1. Tercih
Olası kullanım

FF, SF, NF, FM, SM, NM, SI, NRM, NMR, NR2, OR, HR, HR2, 923



0.05 – 0.2 mm/dev

0.05 – 0.2 mm/dev

0.2 – 0.4 mm/dev

0.4 – 1.0 mm/dev

> 1.0 mm/dev



0.05 – 2 mm

0.05 – 2 mm

2 – 4 mm

4 – 10 mm

> 10 mm

FF		İnce ve finiş işleme, paslanmaz çelik ve çelik, potansiyel olarak dökme demirler ve sürekli kesim için tasarlanmış yüksek düzeyde pozitif geometri
SF		İnce finiş işleme, çelikler, paslanmaz çelikler, dökme demirler, süper alaşımlar ve sert malzemeler, potansiyel olarak demir içermeyen malzemeler ve ince duvarların sürekli kesimli işlenmesi için tasarlanmış çok yönlü pozitif geometri
NF		İnce finiş ve orta işleme, paslanmaz çelikler, çelik, potansiyel olarak dökme demir, demir içermeyen malzemeler ve süper alaşımlar, sürekli kesimler için yüksek düzeyde pozitif tasarım
SM		Orta işleme, paslanmaz çelikler, süper alaşımlar, çelikler ve dökme demirler, potansiyel olarak demir içermeyen ve sert malzemeler ve ince duvarları, sürekli ve darbeli kesimlerle işlemek için tasarlanmış pozitif geometri
NMR		Orta işlemeden kaba işlemeye, paslanmaz çeliklerin ve ayrıca yumuşak çelikler ve süper alaşımlarda sürekli kesimler için pozitif tasarım
NR2		Finiş işlemeden kaba işlemeye, paslanmaz çelikler ve çelikler, potansiyel olarak dökme demirler ve süper alaşımlar, sürekli ve darbeli kesimler için tasarlanmıştır





ISO KESİCİ UÇLAR NEGATİF – TALAŞ KIRICI REHBERİ

K

 Rijit olmayan işleme koşulları

 Biraz daha kötü işleme koşulları

 Rijit işleme koşulları

 İnce cidarlı ve zayıf iş parçaları

1. Tercih

Olası kullanım

.NMA

M

R

HR

923

OR

HR2

SM

KR

NR2

SF

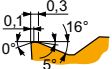
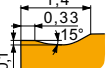
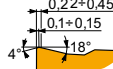
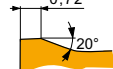

	0.05 – 0.2 mm/dev	0.05 – 0.2 mm/dev	0.2 – 0.4 mm/dev	0.4 – 1.0 mm/dev	> 1.0 mm/dev
	0.05 – 2 mm	0.05 – 2 mm	2 – 4 mm	4 – 10 mm	> 10 mm

.NMA		İnce finiş işlemeden yarı kaba işlemeye, dökme demirler, potansiyel olarak sert malzemeler, sürekli ve hafif darbeli kesimler için tasarlanmıştır
M		Finiş ve yarı kaba işleme, dökme demirler, potansiyel olarak çelikler ve sert malzemeler, sürekli ve darbeli kesimler için tasarlanmıştır
KR		Yarı kaba ve kaba işleme, dökme demirler, potansiyel olarak çelik ve sert malzemeler, sürekli ve darbeli kesimler için tasarlanmıştır
OR		Finiş işlemeden ağır kaba işlemeye, çelikler ve dökme demirler, potansiyel olarak paslanmaz çelik ve süper alaşımlar, sürekli ve darbeli kesimler için tasarlanmıştır
HR2		Yüksek ilerlemeli olarak kaba ve ağır kaba işleme, çelikler ve dökme demirler, potansiyel olarak paslanmaz çelikler, sürekli ve darbeli kesimler için tasarlanmıştır

N



Rijit olmayan işleme koşulları



Biraz daha kötü işleme koşulları



Rijit işleme koşulları



İnce cidarlı ve zayıf iş parçaları



SF



SM







NF



NM



SI

					
f	0.05 – 0.2 mm/dev	0.05 – 0.2 mm/dev	0.2 – 0.4 mm/dev	0.4 – 1.0 mm/dev	> 1.0 mm/dev
a_p	0.05 – 2 mm	0.05 – 2 mm	2 – 4 mm	4 – 10 mm	> 10 mm

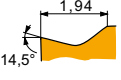
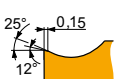
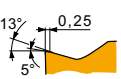
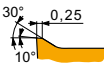
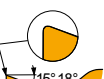
SF		<p>İnce finiş işleme, çelikler, paslanmaz çelikler, dökme demirler, süper alaşımlar ve sert malzemeler, potansiyel olarak demir içermeyen malzemeler ve ince duvarların sürekli kesimli işlenmesi için tasarlanmış çok yönlü pozitif geometri</p>
NF		<p>İnce finiş ve orta işleme, paslanmaz çelikler, çelik, potansiyel olarak dökme demir, demir içermeyen malzemeler ve süper alaşımlar, sürekli kesimler için yüksek düzeyde pozitif tasarım</p>
SM		<p>Orta işleme, paslanmaz çelikler, süper alaşımlar, çelikler ve dökme demirler, potansiyel olarak demir içermeyen ve sert malzemeler ve ince duvarları, sürekli ve darbeli kesimlerle işlemek için tasarlanmış pozitif geometri</p>
NM		<p>İnce finiş, orta ve kaba işleme, paslanmaz çelikler, çelikler, potansiyel olarak demir içermeyen malzemeler ve süper alaşımlar, sürekli kesimler için yüksek düzeyde pozitif tasarım</p>
SI		<p>İnce finiş işlemeden yarı kaba işlemeye, çelikler, paslanmaz çelikler ve dökme demirler ve potansiyel olarak demir içermeyen malzemeler, sürekli kesimler için pozitif geometri</p>





ISO KESİCİ UÇLAR NEGATİF – TALAŞ KIRICI REHBERİ

S

 Rijit olmayan işleme koşulları

 Biraz daha kötü işleme koşulları

 Rijit işleme koşulları

 İnce cidarlı ve zayıf iş parçaları

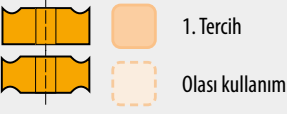

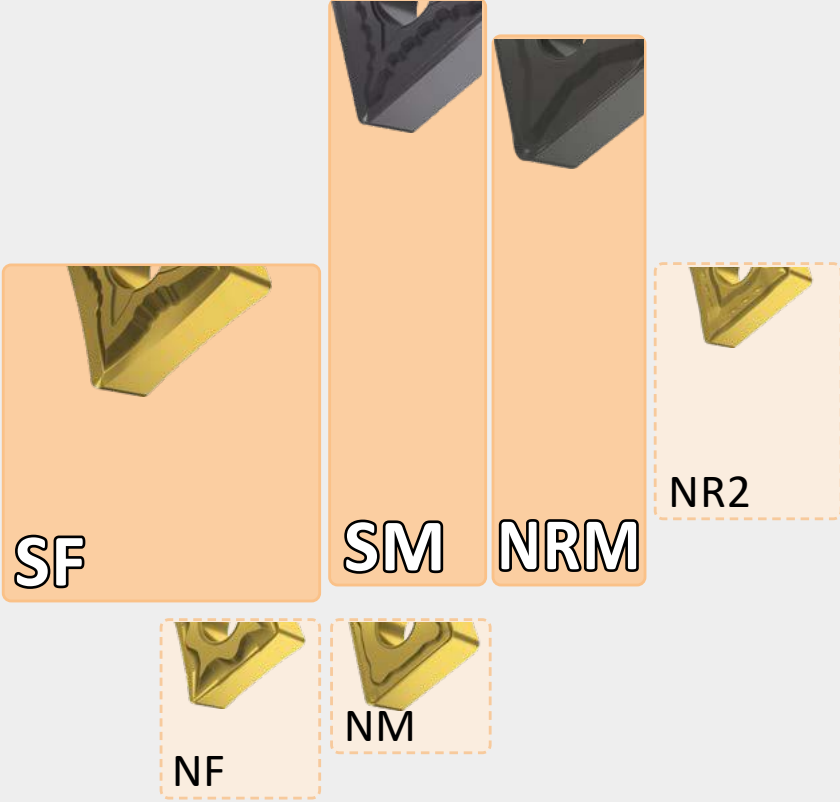

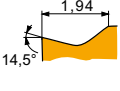
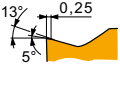
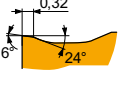

	0.05 – 0.2 mm/dev	0.05 – 0.2 mm/dev	0.2 – 0.4 mm/dev	0.4 – 1.0 mm/dev	> 1.0 mm/dev
	0.05 – 2 mm	0.05 – 2 mm	2 – 4 mm	4 – 10 mm	> 10 mm

SF		İnce finiş işleme, çelikler, paslanmaz çelikler, dökme demirler, süper alaşımlar ve sert malzemeler, potansiyel olarak demir içermeyen malzemeler ve ince duvarların sürekli kesimli işlenmesi için tasarlanmış çok yönlü pozitif geometri		
SM		Orta işleme, paslanmaz çelikler, süper alaşımlar, çelikler ve dökme demirler, potansiyel olarak demir içermeyen ve sert malzemeler ve ince duvarları, sürekli ve darbeli kesimlerle işlemek için tasarlanmış pozitif geometri		
NRM		Yarı kaba ve kaba işleme, paslanmaz çelik, yumuşak çelikler ve süper alaşımlar, sürekli kesimler için pozitif tasarım		

H



Rijit olmayan
işleme koşulları

Biraz daha kötü
işleme koşulları

Rijit işleme
koşulları

İnce cidarlı
ve zayıf iş
parçaları

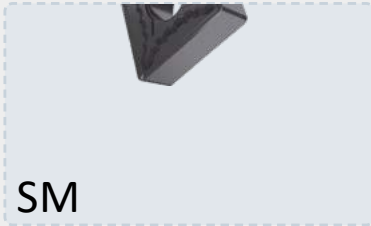
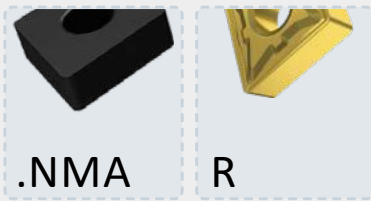
1. Tercih
Olası kullanım



0.05 – 0.2 mm/dev

0.05 – 0.2 mm/dev

0.2 – 0.4 mm/dev

0.4 – 1.0 mm/dev

> 1.0 mm/dev





0.05 – 2 mm

0.05 – 2 mm

2 – 4 mm

4 – 10 mm

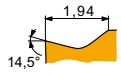
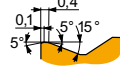
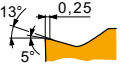
> 10 mm

SF		İnce finiş işleme, çelikler, paslanmaz çelikler, dökme demirler, süper alaşımlar ve sert malzemeler, potansiyel olarak demir içermeyen malzemeler ve ince duvarların sürekli kesimli işlenmesi için tasarlanmış çok yönlü pozitif geometri	R		Yarı kaba ve kaba işleme, dökme demirler, potansiyel olarak çelik ve sert malzemeler, sürekli ve darbeli kesimler için tasarlanmıştır
SM		Orta işleme, paslanmaz çelikler, süper alaşımlar, çelikler ve dökme demirler, potansiyel olarak demir içermeyen ve sert malzemeler ve ince duvarları, sürekli ve darbeli kesimlerle işlemek için tasarlanmış pozitif geometri			
.NMA		İnce finiş işlemeyen yarı kaba işleme, dökme demirler, potansiyel olarak sert malzemeler, sürekli ve hafif darbeli kesimler için tasarlanmıştır			



TORNALAMA KALİTELERİ – REHBER

Grup	MTCVD'li semente karbür	PVD'li semente karbür	Semente karbür	SERMET
P01				
P05	T9310			TT010
P10		T6310		
P15	T9315			
P20				TT310
P25	T9325			
P30		T8430		
P35	T9335			
P40				
P45				
P50				

Grup	MTCVD'li semente karbür	PVD'li semente karbür	Semente karbür	SERMET
M01				
M05				
M10		T6310		
M15				
M20	T7325			
M25		T8315		
M30	T7335			
M35		T8430		
M40				

Grup	MTCVD'li semente karbür	PVD'li semente karbür	Semente karbür	SERMET
K01				
K05	T5305			
K10				
K15	T5315			
K20			HF7	
K25				
K30		T8430		
K35				
K40				

Grup	MTCVD'li semente karbür	PVD'li semente karbür	Semente karbür	SERMET
N01				
N05				
N10				
N15		T0315		
N20			HF7	
N25				
N30				

Grup	MTCVD'li semente karbür	PVD'li semente karbür	Semente karbür	SERMET
S01				
S05				
S10		T6310		
S15			H07	
S20	T7325			
S25	T7335			
S30				

Grup	MTCVD'li semente karbür	PVD'li semente karbür	Semente karbür	SERMET
H01				
H05				
H10	T5305	T6310		
H15		T8315		
H20	T9315			
H25				
H30				



TORNALAMA KALİTELERİ – REHBER

Kalite Tanımlama	Uygulama Alanı	Uygulama	İlerleme	Kesme hızı	Olumsuz Çalışma Koşullarına Direnç	Kaplama	Renk	Altyapı	Kesme sıvısı avantajı	Kalite açıklaması
T9310	P01 - P15	■				MT-CVD		FGM	++	Hafif darbeli kesimler için kullanılabilen yüksek aşınma direncine sahip kalite. Bu kalite finiş işleme veya yarı kaba işleme operasyonları için kullanılır. Bu malzeme, takım tezgahı-ış parçası konfigürasyonunun yeterince rijit olması koşuluyla kaba işleme operasyonları için de kullanılabilir.
	K05 - K20	■	▴	▴	▴					
	H10 - H20	■								
T9315	P05 - P25	■				MT-CVD		FGM	++	Şiddetli kesme koşulları altında bile mükemmel aşınma direnci özelliklerine sahip çok yönlü bir kalite. Darbeli kesimlerin olduğu operasyonlar için de kullanılabilir. Dengeli özellikleriyle bu kalite, çok çeşitli tornalama işlemleri için ilk tercih olabilir. Düşük kesme hızları için uygun değildir.
	K05 - K25	■	▴	▴	▴					
	H10 - H20	■								
T9325	P15 - P35	■				MT-CVD		FGM	++	Teknolojik açıdan bakıldığında bu, olumsuz kesme koşullarında mekanik hasara karşı yüksek dirence sahip son derece çok yönlü bir kalitedir ve mükemmel aşınma direncini korur. Bu malzemenin doğru uygulanması için yüksek kesme hızları gerekir.
	M10 - M30	■	▴	▴	▴					
	K15 - K35	■								
	S10 - S20	■								
T9335	P20 - P45	■				MT-CVD		FGM	+++	Orta ila yüksek ilerleme hızlarında ve orta kesme hızlarında özellikle olumsuz kesme koşulları için uygun olan en tok kalitelere biridir. Önceki modellere kıyasla M15 - M40 sadece daha tok değil, aynı zamanda aşınmaya karşı daha dayanıklıdır ve bu özellik yoğun kesme koşullarında avantaj sağlar.
	M15 - M40	■	▴	▴	▴					
	S15 - S25	■								
T7325	P15 - P35	■				MT-CVD		FGM	+++	En üniversal tornalama kalitelerinden biridir. Paslanmaz çelik işleme için özel olarak tasarlanmıştır. Aşınma direnci ve performans güvenilirliği arasında optimum denge sunar. Tornalama işlemlerinde çok çeşitli uygulamalar için uygundur.
	M10 - M25	■	▴	▴	▴					
	S10 - S25	■								
T7335	P20 - P40	■				MT-CVD		FGM	+++	Çok yüksek operasyonel güvenilirliğe ve çok iyi aşınma direncine sahip, fonksiyonel bir şekilde derecelendirilmiş altyapısı bulunan kalitedir. En uygun kullanım alanı yüksek tokluğa sahip M20 - M40 malzemelerin işlenmesidir.
	M20 - M40	■	▴	▴	▴					
	S15 - S25	■								
T5305	P05 - P15	■				MT-CVD		H	+	Kimyasal aşınmaya karşı çok yüksek dirençli kalitedir; yüksek kesme hızları kullanan finiş işleme operasyonları için uygundur. Ayrıca, yüksek aşınma direnci sayesinde sertleştirilmiş ve işlenmiş K01 - K15 malzemelerin verimli bir şekilde işlenmesi için de uygundur.
	K01 - K15	■	▴	▴	▴					
	H05 - H15	■								
T5315	P10 - P25	■				MT-CVD		H	+	Öncelikle verimli işlemeye yönelik, yüksek aşınma direncine ve iyi operasyonel güvenilirliğe sahip kalite. Özellikleri sayesinde bu malzeme iyi veya hafif olumsuz kesme koşullarında kaba ve finiş işleme operasyonları için uygundur.
	K10 - K25	■	▴	▴	▴					
	H15 - H25	■								
6640	P20 - P40	■				MT-CVD		H	+++	Özellikle kaba işleme operasyonlarında veya olumsuz kesme koşulları altında operasyonel güvenilirliğin öncelikli olduğu durumlarda kullanılabilen en tok tornalama malzemelerinden biridir. Düşük ila orta kesme hızlarında ve orta ila yüksek ilerleme hızlarında çalışan makineler için diğer bir ideal seçimdir.
	M20 - M35	■	▴	▴	▴					
	K25 - K40	■								



TORNALAMA KALİTELERİ – REHBER

Kalite Tanımlama	Uygulama Alanı	Uygulama	İlerleme	Kesme hızı	Olumsuz Çalışma Koşullarına Direnç	Kaplama	Renk	Altyapı	Kesme sıvısı avantajı	Kalite açıklaması
T8315	P05 - P20	■				PVD	■	submicron H	++	Ortalamanın üzerinde operasyonel güvenilirliği korurken mükemmel aşınma direncine sahip kalitedir ve kısa talaşlı sert malzemelerde orta ila yüksek kesme hızlarında işleme için uygundur.
	M05 - M20	■								
	K05 - K25	■								
	N05 - N25	■	■	■	■					
	S05 - S15	■								
	H05 - H15	■								
T8430 NEW	P20 - P40	■				PVD	■	submicron H	+++	Çok yönlülük açısından kuşkusuz en güçlü kesme malzemesi olan bu kalite tüm işlenmiş malzemelerin işlenmesinde kullanılır ve hemen her tür tormalama işleminde pratik olarak uygulanabilir. Başlıca avantajları yüksek operasyonel güvenilirlik ve çok iyi sürtünme özellikleridir; bu nedenle orta ve düşük kesme hızlarındaki uygulamalar için uygundur.
	M20 - M35	■								
	K25 - K40	■	■	■	■					
	N15 - N30	■	■	■	■					
	S15 - S25	■								
	H15 - H25	■								
T8330	P25 - P40	■				PVD	■	submicron H	+++	Çok yönlü bir kesme malzemesi olan bu kalite tüm işlenmiş malzemelerin işlenmesinde kullanılır ve hemen her tür tormalama işleminde pratik olarak uygulanabilir. Başlıca avantajları yüksek operasyonel güvenilirlik ve çok iyi sürtünme özellikleridir; bu nedenle orta ve düşük kesme hızlarındaki uygulamalar için uygundur.
	M20 - M35	■								
	K20 - K40	■	■	■	■					
	N15 - N30	■	■	■	■					
	S15 - S25	■								
	H15 - H25	■								
T8345	P30 - P50	■				PVD	■	submicron H	+++	Bu kalite, en tok tormalama kalitesidir ve esas olarak en kötü kesme koşullarında ve en yüksek çalışma güvenilirliği gereksinimleri olan uygulamalarda işleme için tasarlanmıştır. Bu özelliklerinden dolayı bu malzeme daha düşük kesme hızları için tavsiye edilir.
	M20 - M40	■								
	K30 - K40	■	■	■	■					
	S20 - S30	■								
T6310	P01 - P15	■				PVD	■	ultra submicron H	+++	Üstü PVD kaplamalı, yüksek aşınmaya dayanıklı tormalama kalitesidir. Keskin kesme kenarı ve yüksek yanak aşınma direncinin çok önemli olduğu finiş işleme operasyonları ve uygulamaları için uygundur
	M01 - M15	■								
	K05 - K20	■	■	■	■					
	N05 - N20	■	■	■	■					
	S01 - S15	■								
	H01 - H15	■								
T0315	N05 - N20	■	■	■	■	PVD	■	submicron H	++	Demir dışı metalleri ve alaşımlarını dengeli bir aşınma direnci ve tokluk oranıyla tormalamak için mikron altı kalitedir. Mükemmel sürtünme özelliklerine sahip benzersiz bir kaplama ile sunulur.
HF7	M10 - M20	■				×	■	submicron H	++	Esas olarak demir dışı metallerin işlenmesi için tasarlanmış kaplamasız kalitedir; ancak diğer işlenmiş malzemeler için de kullanılabilir (çelik hariç). Bu malzeme tormalama, frezeleme ve hatta delik işlemede kullanılabilir.
	K10 - K25	■	■	■	■					
	N10 - N25	■								
H07	M05 - M15	■				×	■	submicron H	++	Oksidasyon direncinin takım ömrü açısından baskın kriter olmadığı işleme uygulamalarında kullanılan kaplamasız tormalama kalitesidir. Ti bazlı alaşımların işlenmesi için tasarlanmıştır. Kalite, iyi aşınma direnci ile birlikte yüksek kesme kenarı mukavemeti sergiler.
	K10 - K25	■	■	■	■					
	N10 - N30	■	■	■	■					
	S01 - S20	■								
TT310	P10 - P25	■	■	■	■	PVD	■	cermet	+/-	Karbon ve alaşımlı çeliklerin (paslanmaz dahil) ince ve yüzey tormalanmasında kullanılan kaplamalı sermet. PVD tekniğiyle uygulanan kaplama sayesinde mükemmel sürtünme özellikleri daha da iyileştirilmiştir.
	M15 - M25	■								



TORNALAMA KALİTELERİ – REHBER

Kalite Tanımlama	Uygulama Alanı	Uygulama	İlerleme	Kesme hızı	Olumsuz Çalışma Koşullarına Direnç	Kaplama	Renk	Altyapı	Kesme sıvısı avantajı	Kalite açıklaması
TT010	P01 - P10	■				×		cermet	+ / -	Her tür çeliğin (paslanmaz dahil) çok düşük ilerleme hızlarında ince işlenmesi için uygun kaplamasız sermet. Başlıca avantajı, kesme kenarının minimum yarıçapı ve fiziksel ve kimyasal aşınma mekanizmalarına karşı yüksek direncidir.
	M01 - M10	■				×		cermet	+ / -	
TC100	K01 - K15	■				×		ceramics	--	Dökme demir işleme için seramik kalitesi. Stabil koşullarda yüksek kesme hızıyla işlemeye uygundur.
	K01 - K10	■				×		ceramics	--	
TB310	S05 - S10	■				×		CBN	--	Sertleştirilmiş malzemelerin işlenmesi için CBN kalitesi. Stabil koşullarda yüksek kesme hızı ve küçük ilerlemelerle işlemeye uygundur.
	H01 - H10	■				×		CBN	--	
PD1	N05 - N25	■				×		PCD	-	Demir içermeyen malzemeleri tormalamak için PKD kalitesi. Stabil koşullarda yüksek kesme hızı ve küçük ilerlemelerle işleme için ideal tercihtir.
333TN	P45 - P50	■				×		HSS	+++	HSS altyapısı ve ince sert PVD kaplamadan oluşan özel kalitedir. Portföydeki en tok kesme kalitesidir. Bu kaliteye sahip kesici uçlar sadece kama oluğu açmak için kullanılır.
	M35 - M40	■				×	PVD			
	K35 - K40	■				×	PVD			

Alt yapı

H	WC-Co bazlı alt yapı
submicron H	İnce tanecikli (< 1 µm) WC-Co bazlı alt yapı
ultra submicron H	Çok ince tanecikli (< 0,5 µm) WC-Co bazlı alt yapı
FGM	İşlevsel kaliteli alt yapı
Cermet	WC'süz sementte karbür
ceramics	Seramik
PCD	Polikristal Elmas
CBN	Kübik Boron Nitrür
HSS	Yüksek hız çeliği

Kesme sıvısının avantajları

+++	Kesme sıvısı kullanımı esastır
++	Önemle tavsiye edilir
+	Tavsiye edilir
+ / -	İsteğe bağlı
--	Kesme sıvısı kullanılmayın
-	Kesme sıvısı tavsiye edilmez

Kaplama

MT-CVD	Orta sıcaklıkta kimyasal kaplama
PVD	Düşük sıcaklıkta fiziksel kaplama
×	Kaplamasız kalite

ISO TORNALAMA - DIŞ

UZUN VE STABİL OLMAYAN PARÇALAR (Pozitif uçlar)

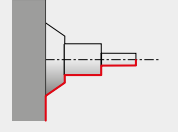

SCAC(RL) EXT	
90°	CC..
	06 09
	08×08 16×16
	70
	60-69

SCBC(RL) EXT	
75°	CC..
	09 12
	12×12 25×25
	71
	60-69

SCDCR EXT	
45°	CC..
	06
	10×10
	72
	60-69

SCFC(RL) EXT	
90°	CC..
	06 09
	08×08 16×16
	73
	60-69

SCLC(RL) EXT	
95°	CC..
	06 08 09 12
	08×08 25×25
	74
	60-69

SDJC(RL) EXT	
93°	DC..
	07 11 15
	08×08 25×25
	94
	86-93

SDNCN EXT	
62°30'	DC..
	7 11
	08×08 25×25
	95
	86-93

SEGC(RL) EXT	
90°	EC..
	08
	12×12 16×16
	107
	104-106

SRDC(RL) EXT	
	RC..
	08
	20×20 32×25
	126
	118-123

SRDCN EXT	
	RC..
	06 08 10 12 16
	12×12 32×25
	127
	118-123

SRSC(RL) EXT	
	RC..
	06 08 10 12 16
	12×12 32×25
	128
	118-123

SSBC(RL) EXT	
75°	SC..
	09 12 25 38
	12×12 60×60
	139
	134-138

SSDCN EXT	
45°	SC..
	09 12
	12×12 25×25
	140
	134-138

SSKC(RL) EXT	
75°	SC..
	09 12
	12×12 25×25
	141
	134-138

STFC(RL) EXT	
90°	TC..
	11 16
	16×16 25×25
	155
	149-154

STFC(RL)-A EXT	
90°	TC..
	11
	20×20
	156
	149-154

ISO TORNALAMA - DIŞ

UZUN VE STABİL OLMAYAN PARÇALAR (Pozitif uçlar)

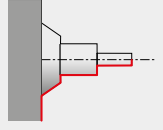

STJC(RL) EXT

93°

TC..

11
16

16×16
25×25

157 149 – 154

SVAC(RL)-DC EXT

90°

VC..

13

10×10
25×25

193 186 – 192

SVGC(RL) EXT

90°

VC..

07

08×08
16×16

194 186 – 192

SVHB(C)(RL) EXT

107°30'

VB, VC..

11
16

16×16
25×25

172, 195 168 – 171
186 – 192

SVJB(C)(RL) EXT

93°

VB, VC..

11
13
16

12×12
32×25

173, 196 168 – 171
186 – 192

SVJC(RL)-DC EXT

93°

VC..

13

10×10
25×25

197 186 – 192

SVPB(C)(RL) EXT

117°30'

VB, VC..

11
16

16×16
32×25

174, 198 168 – 171
186 – 192

SVVB(C)N EXT

72°30'

VB, VC..

11
13
16

12×12
32×25

175, 199 168 – 171
186 – 192

SVXB(C)(RL) EXT

98°

VB, VC..

11
13
16

12×12
32×25

176, 200 168 – 171
186 – 192

SWLC(RL) EXT

95°

WC..

06
08

16×16
25×25

215 212 – 214

CKJN(RL) EXT

93°

KN..

16

20×20
32×25

287 284 – 286

C.-SCLC(RL) EXT NEW

95°

CC..

09
12

20
32

75 60 – 69

C.-SDJC(RL) EXT NEW

93°

DC..

11

C3
C5

96 86 – 93

C.-SDNCN EXT NEW

62°30'

DC..

11

C4
C5

97 86 – 93

C.-SRDCN EXT NEW

90°

RC..

10
12

C4
C5

130 118 – 123

C.-SVHB(RL) EXT NEW

107°30'

VB, VC..

16

C4
C6

177, 201 168 – 171
186 – 192



ISO TORNALAMA - DIŞ

UZUN VE STABİL OLMAYAN PARÇALAR (Pozitif uçlar)

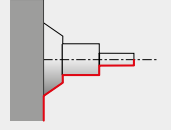

C.-SVJB(RL) EXT **NEW**

93°		VB, VC..
		11 16
	C3 C6	
	178, 202	168 – 171 186 – 192

C.-SVVBN EXT **NEW**

72°30'		VB, VC..
		16
	C4 C6	
	179, 203	168 – 171 186 – 192

ISO TORNALAMA - İÇ

UZUN VE STABİL OLMAYAN PARÇALAR (Pozitif uçlar)

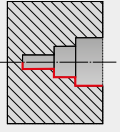

SCFC(RL) INT

90° CC..

06

$\frac{13}{16}$

76 60-69

SCKC(RL) INT

75° CC..

06
09
12

$\frac{11}{40}$

77 60-69

SCLC(RL) INT

95° CC..

06
09
12

$\frac{11}{40}$

78 60-69

SCXC(RL) INT

40° CC..

06

$\frac{13}{20}$

80 60-69

SDQC(RL) INT

107°30' DC..

07
11

$\frac{13}{40}$

98 86-93

SDUC(RL) INT

93° DC..

07
11

$\frac{13}{40}$

99 86-93

SDUC(RL)-E INT

93° DC..

07
11

$\frac{13}{40}$

100 86-93

SDZC(RL) INT

93° DC..

07
11

$\frac{27}{65}$

101 86-93

SELP(RL) INT

95° EP..

05

$\frac{8}{16}$

111 110

SELP(RL)-E INT

95° EP..

05

$\frac{8}{16}$

112 110

SEUC(RL) INT

93° EC..

06
08

$\frac{11}{32}$

108 104-106

SEUP(RL) INT

93° EP..

05

8.3

113 110

SEXP(RL) INT

52°30' EP..

05

$\frac{9.5}{16}$

114 110

SEXP(RL)-E INT

52°30' EP..

05

$\frac{9.5}{16}$

115 110

SSSC(RL) INT

45° SC..

09

$\frac{25}{32}$

144 134-138

STFC(RL) INT

90° TC..

06
09
11
16

$\frac{8.5}{40}$

158 149-154

ISO TORNALAMA - İÇ

UZUN VE STABİL OLMAYAN PARÇALAR (Pozitif uçlar)

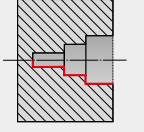

STFC(RL)-E INT	
90°	TC..
	 06 09 11
160	149 – 154

SVJB(RL) INT	
93°	VB, VC..
	 11
180, 204	168 – 171 186 – 192

SVLC(RL) INT	
95°	VC..
	 13
205	186 – 192

SVQB(C)(RL) INT	
107°30'	VB, VC..
	 11 13 16
181, 206	168 – 171 186 – 192

SVUB(C)(RL) INT	
93°	VB, VC..
	 11 13 16
182, 207	168 – 171 186 – 192

SVXC(RL) INT	
113°	VC..
	 07
208	186 – 192

SVXC(RL)-E INT	
113°	VC..
	 07
209	186 – 192

SWLC(RL) INT	
95°	WC..
	 06 08
216	212 – 214

SWUC(RL) INT	
93°	WC..
	 02
217	212 – 214

SWUC(RL)-E INT	
93°	WC..
	 02
218	212 – 214

C.-SCLC(RL) INT NEW	
95°	CC..
	 09
81	60 – 69

C.-SDUC(RL) INT NEW	
93°	DC..
	 07 11
102	86 – 93

C.-SVQB(C)(RL) INT NEW	
108°	VB, VC..
	 16
183, 210	168 – 171 186 – 192

ISO TORNALAMA - DIŞ

KISA VE STABİL PARÇALAR (Negatif uçlar)

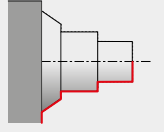

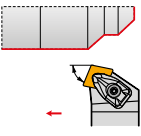
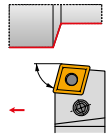
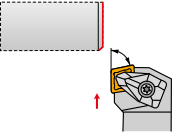
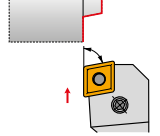
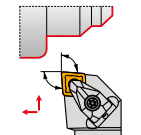
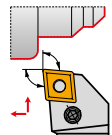
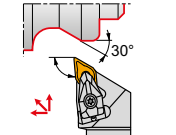
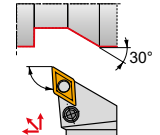
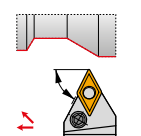
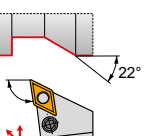
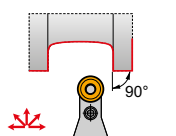
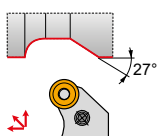
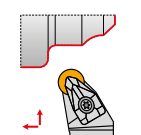
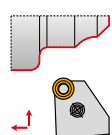
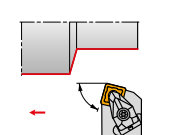
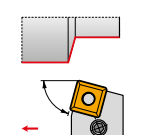
<p>DCBN(RL) EXT</p> <p>75°</p> <p>CN..</p>  <p>12 16 19</p> <p>20×20 40×40</p> <p>240</p> <p>222 – 239</p>	<p>PCBN(RL) EXT</p> <p>75°</p> <p>CN..</p>  <p>12 16 19 25</p> <p>20×20 50×50</p> <p>245</p> <p>222 – 239</p>	<p>DCKN(RL) EXT</p> <p>75°</p> <p>CN..</p>  <p>12 16</p> <p>20×20 32×32</p> <p>242</p> <p>222 – 239</p>	<p>PCKN(RL) EXT</p> <p>75°</p> <p>CN..</p>  <p>12 16 19</p> <p>20×20 40×40</p> <p>246</p> <p>222 – 239</p>
<p>DCLN(RL) EXT</p> <p>95°</p> <p>CN..</p>  <p>09 12 16 19</p> <p>16×16 40×40</p> <p>243</p> <p>222 – 239</p>	<p>PCLN(RL) EXT</p> <p>95°</p> <p>CN..</p>  <p>12 16 19 25</p> <p>20×20 50×50</p> <p>247</p> <p>222 – 239</p>	<p>DDJN(RL) EXT</p> <p>93°</p> <p>DN..</p>  <p>11 15</p> <p>20×20 32×32</p> <p>273</p> <p>260 – 272</p>	<p>PDJN(RL) EXT</p> <p>93°</p> <p>DN..</p>  <p>11 15</p> <p>20×20 32×32</p> <p>274</p> <p>260 – 272</p>
<p>PDNN(RL) EXT</p> <p>62°30'</p> <p>DN..</p>  <p>11 15</p> <p>20×20 32×25</p> <p>275</p> <p>260 – 272</p>	<p>PDXN(RL) EXT</p> <p>98°</p> <p>DN..</p>  <p>15</p> <p>20×20 32×25</p> <p>276</p> <p>260 – 272</p>	<p>PRDCN EXT</p> <p>RC..</p>  <p>16 20 25 32</p> <p>32×25 50×50</p> <p>124</p> <p>118 – 123</p>	<p>PRSC(RL) EXT</p> <p>RC..</p>  <p>16 20 25</p> <p>32×25 40×40</p> <p>125</p> <p>118 – 123</p>
<p>DRSN(RL) EXT</p> <p>RN..</p>  <p>12</p> <p>25×25</p> <p>295</p> <p>294</p>	<p>PRSN(RL) EXT</p> <p>RN..</p>  <p>12 15 19</p> <p>25×25 40×40</p> <p>296</p> <p>294</p>	<p>DSBN(RL) EXT</p> <p>75°</p> <p>SN..</p>  <p>12 15 19</p> <p>20×20 40×40</p> <p>313</p> <p>300 – 312</p>	<p>PSBN(RL) EXT</p> <p>75°</p> <p>SN..</p>  <p>12 15 19 25</p> <p>20×20 50×50</p> <p>318</p> <p>300 – 312</p>

ISO TORNALAMA - DIŞ

KISA VE STABİL PARÇALAR (Negatif uçlar)

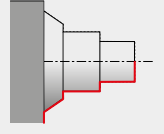

DSDNN EXT	
45°	SN..
	12 15 19 25
	20×20 40×40
	315
	300–312

PSDNN EXT	
45°	SN..
	12 15 19 25
	20×20 50×50
	320
	300–312

DSKN(RL) EXT	
75°	SN..
	12 19
	25×25 32×32
	316
	300–312

PSKN(RL) EXT	
75°	SN..
	12 15 19 25
	20×20 50×50
	321
	300–312

DSSN(RL) EXT	
45°	SN..
	12 15 19
	20×20 40×40
	317
	300–312

PSSN(RL) EXT	
45°	SN..
	12 15 19 25
	20×20 50×50
	323
	300–312

DTFN(RL) EXT	
90°	TN..
	16 22
	20×20 25×25
	345
	334–344

PTFN(RL) EXT	
90°	TN..
	16 22 27
	16×16 40×40
	348
	334–344

DTGN(RL) EXT	
90°	TN..
	16 22
	20×20 32×25
	346
	334–344

PTGN(RL) EXT	
90°	TN..
	16 22 27
	16×16 40×40
	349
	334–344

MTJN(RL) EXT	
93°	TN..
	16 22
	16×16 32×32
	347
	334–344

PTTN(RL) EXT	
60°	TN..
	16 22
	20×20 32×25
	350
	334–344

DVJN(RL) EXT	
93°	VN..
	16
	20×20 32×25
	360
	356–376

MVJN(RL) EXT	
93°	VN..
	16
	20×20 32×25
	362
	356–376

DVPN(RL) EXT	
62°30'	VN..
	16
	20×20 32×25
	361
	356–376

DWLN(RL) EXT	
95°	WN..
	06 08 10 13
	16×16 40×40
	377
	366–376

ISO TORNALAMA - DIŞ

KISA VE STABİL PARÇALAR (Negatif uçlar)

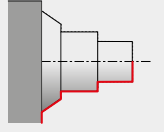

MWLN(RL) EXT

95°	WN..
	08
	25×25 40×40
379	366 – 376

PWLN(RL) EXT

95°	WN..
	06 08
	16×16 32×25
380	366 – 376

C.-DCLN(RL) EXT NEW

95°	CN..
	12 16 19
	C3 C8
249	222 – 239

C.-DDJN(RL) EXT NEW

93°	DN..
	11 15
	C4 C6
277	260 – 272

C.-DDNNN EXT NEW

62.5°	DN..
	15
	C5 C6
278	260 – 272

C.-DDUN(RL) EXT NEW

93°	DN..
	15
	C5 C6
279	260 – 272

C.-DRSN(RL) EXT NEW

	RN..
	12
	C6
297	294

C.-DSRN(RL) EXT NEW

75°	SN..
	12 19
	C4 C6
326	300 – 312

C.-DSDNN EXT NEW

45°	SN..
	12 19
	C4 C6
324	300 – 312

C.-DSKN(RL) EXT NEW

75°	SN..
	12
	C4
325	300 – 312

C.-DSSN(RL) EXT NEW

45°	SN..
	12
	C4 C5
327	300 – 312

C.-DTJN(RL) EXT NEW

93°	TN..
	16
	C4 C5
351	334 – 344

C.-DVJN(RL) EXT NEW

93°	VN..
	16
	C4 C6
363	356 – 376

C.-DWLN(RL) EXT NEW

95°	WN..
	06 08
	C4 C6
381	366 – 376

ISO TORNALAMA - İÇ

KISA VE STABİL PARÇALAR (Negatif uçlar)

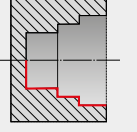

DCLN(RL) INT	
95°	CN..
	09 12
	$\frac{32}{50}$
254	222-239

PCLN(RL) INT	
95°	CN..
	09 12 16 19
	$\frac{20}{80}$
255	222-239

DDUN(RL) INT	
93°	DN..
	11 15
	$\frac{25}{50}$
280	260-272

PDUN(RL) INT	
93°	DN..
	11 15
	$\frac{25}{60}$
281	260-272

PSKN(RL) INT	
93°	SN..
	11 15
	$\frac{32}{80}$
331	300-312

DTFN(RL) INT	
90°	TN..
	16 22
	$\frac{32}{50}$
352	334-344

PTFN(RL) INT	
90°	TN..
	16 22
	$\frac{32}{50}$
353	334-344

DVUN(RL) INT	
	VN..
	16
	50
364	356-376

DWLN(RL) INT	
95°	WN..
	06 08
	$\frac{32}{63}$
382	366-376

PWLN(RL) INT	
95°	WN..
	06 08
	$\frac{20}{80}$
383	366-376

C.-DCLN(RL) INT NEW	
95°	CN..
	09 12 16
	$\frac{25}{50}$
257	222-239

C.-DDUN(RL) INT NEW	
93°	DN..
	11
	12
282	260-272

C.-DTFN(RL) INT NEW	
91°	TN..
	16
	32
354	334-344

C.-DWLN(RL) INT NEW	
95°	WN..
	06 08
	$\frac{27}{33}$
385	366-376

ISO TORNALAMA - AĞIR KABA - DIŞ
SABİT KATERLER

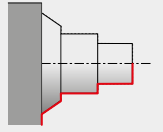

<p>DCBN(RL) EXT</p> <p>75°</p> <p>CN..</p> <p>19</p> <p>40×40</p> <p>240</p> <p>222 – 239</p>	<p>PCBN(RL) EXT</p> <p>75°</p> <p>CN..</p> <p>19</p> <p>25</p> <p>40×40</p> <p>50×50</p> <p>245</p> <p>222 – 239</p>	<p>PCKN(RL) EXT</p> <p>75°</p> <p>CN..</p> <p>19</p> <p>40×40</p> <p>246</p> <p>222 – 239</p>	<p>DCLN(RL) EXT</p> <p>95°</p> <p>CN..</p> <p>19</p> <p>40×40</p> <p>243</p> <p>222 – 239</p>
<p>PCLN(RL) EXT</p> <p>95°</p> <p>CN..</p> <p>19</p> <p>25</p> <p>40×40</p> <p>50×50</p> <p>247</p> <p>222 – 239</p>	<p>PLBN(RL) EXT</p> <p>75°</p> <p>LN..</p> <p>40</p> <p>50</p> <p>60×60</p> <p>290</p> <p>289</p>	<p>PRDCN EXT</p> <p>RC..</p> <p>20</p> <p>25</p> <p>32</p> <p>40×40</p> <p>50×50</p> <p>124</p> <p>118 – 123</p>	<p>PRSC(RL) EXT</p> <p>RC..</p> <p>16</p> <p>25</p> <p>40×40</p> <p>125</p> <p>118 – 123</p>
<p>PRSN(RL) EXT</p> <p>RN..</p> <p>19</p> <p>40×40</p> <p>296</p> <p>294</p>	<p>DSBN(RL) EXT</p> <p>75°</p> <p>SN..</p> <p>19</p> <p>40×40</p> <p>313</p> <p>300 – 312</p>	<p>PSBN(RL) EXT</p> <p>75°</p> <p>SN..</p> <p>19</p> <p>25</p> <p>40×40</p> <p>50×50</p> <p>318</p> <p>300 – 312</p>	<p>DSDNN EXT</p> <p>45°</p> <p>SN..</p> <p>19</p> <p>25</p> <p>40×40</p> <p>315</p> <p>300 – 312</p>
<p>PSDNN EXT</p> <p>45°</p> <p>SN..</p> <p>19</p> <p>25</p> <p>40×40</p> <p>50×50</p> <p>320</p> <p>300 – 312</p>	<p>PSKN(RL) EXT</p> <p>75°</p> <p>SN..</p> <p>19</p> <p>25</p> <p>40×40</p> <p>50×50</p> <p>321</p> <p>300 – 312</p>	<p>DSSN(RL) EXT</p> <p>45°</p> <p>SN..</p> <p>19</p> <p>40×40</p> <p>317</p> <p>300 – 312</p>	<p>PSSN(RL) EXT</p> <p>45°</p> <p>SN..</p> <p>19</p> <p>25</p> <p>40×40</p> <p>50×50</p> <p>323</p> <p>300 – 312</p>



ISO TORNALAMA - AĞIR KABA - DIŞ
SABİT KATERLER

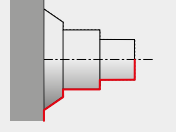

SSBC(RL) EXT	
75°	SC..
	25 38
139	134 - 138

DWLN(RL) EXT	
95°	WN..
	13
377	366 - 376

ISO TORNALAMA - AĞIR KABA - DIŞ
KAFA (KH)

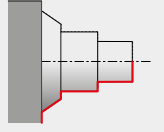

KHP-CBNR + DKH(RL)

75°

CN..

25

DKHR+KHP-CBNR

	40×50 60×80
--	----------------

251, 253 222 – 239

KHP-CBNL + DKH(RL)

75°

CN..

25

DKHR+KHP-CBNL

	40×50 60×80
--	----------------

251, 253 222 – 239

KHP-CLNR/L + DKH(RL)

95°

CN..

19
25

DKHR+KHP-CLNR

	40×50 60×80
--	----------------

252, 253 222 – 239

KHP-LBNR + DKH(RL)

75°

LN..

40

DKHR+KHP-LBNR

	40×50 60×80
--	----------------

291, 292 289

KHP-LBNL + DKH(RL)

75°

LN..

40

DKHR+KHP-LBNL

	40×50 60×80
--	----------------

291, 292 289

KHP-RSCR/L + DKH(RL)

RC..

20
25
32

DKHR+KHP-RSCR

	40×50 60×80
--	----------------

131, 132 118 – 123

KHP-SBNR + DKH(RL)

75°

SN..

25

DKHR+KHP-SBNR

	40×50 60×80
--	----------------

328, 330 300 – 312

KHP-SBNL + DKH(RL)

75°

SN..

25

DKHR+KHP-SBNL

	40×50 60×80
--	----------------

328, 330 300 – 312

KHP-SSNR/L + DKH(RL)

45°

SN..

19
25

DKHR+KHP-SSNR

	40×50 60×80
--	----------------

329, 330 300 – 312

KHS-SBCR + DKH(RL)

75°

SC..

25
38

DKHR+KHS-SBC

	40×50 60×80
--	----------------

142, 143 134 – 138

KHS-SBCL + DKH(RL)

75°

SC..

25
38

R DKHR+KHS-SBCL

	40×50 60×80
--	----------------

142, 143 134 – 138



DORMER PRAMET



HER ZAMAN ÇEVİRİMİÇİ

İnternet bağlantınız ya da wifi yok mu? İşleme hesaplayıcısı, en ihtiyacınız olduğu zamanlarda bağlantınız olmasa bile çalışır.
Simply Reliable.

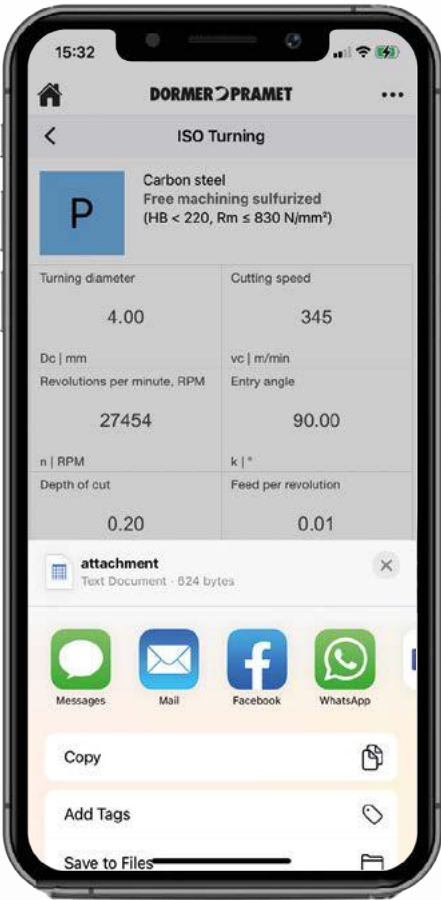



DORMER PRAMET

TAKİP EDİN



PAYLAŞ



BEĞEN



YORUMLA



ETİKETLE



RE-TWEET



UÇLAR – ISO KODLAMA SİSTEMİ

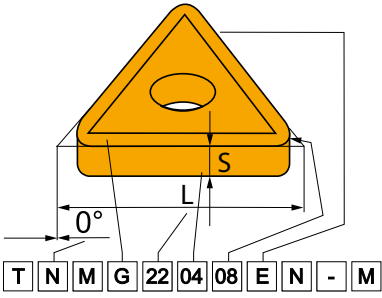

ISO	1	2	3	4
	T	N	U	N
ANSI	1	2	3	4
	T	N	U	G

1				2				4														
Uç şekli				Serbest açı				Talaş kırıcı ve sıkma tipi														
H	O	P	R	A	B	C	D	N	R	F	A	M	G	W	T	Q	U	B	H	C	J	X
																						Özel
S	T	C	D	E	F	G	N	O	Özel													
E	M	V	W																			
L	A	B	K																			

3									
Toleranslar									
	(mm)			(")					
	M (±)	S (±)	IC (±)	M (±)	S (±)	IC (±)			
A	0.005	0.025	0.025	.0002"	.001"	.0010"			
F	0.005	0.025	0.013	.0002"	.001"	.0005"			
C	0.013	0.025	0.025	.0005"	.001"	.0010"			
H	0.013	0.025	0.013	.0005"	.001"	.0005"			
E	0.025	0.025	0.025	.0010"	.001"	.0010"			
G	0.025	0.130	0.025	.0010"	.005"	.0010"			
J	0.005	0.025	0.05 – 0.13	.0002"	.001"	.002 – 0.005"			
K	0.013	0.025	0.05 – 0.13	.0005"	.001"	.002 – 0.005"			
L	0.025	0.025	0.05 – 0.13	.0010"	.001"	.002 – 0.005"			
M	0.08 – 0.18	0.130	0.05 – 0.13	.003 – 0.007"	.005"	.002 – 0.005"			
N	0.08 – 0.18	0.025	0.05 – 0.13	.003 – 0.007"	.001"	.002 – 0.005"			
U	0.05 – 0.38	0.130	0.05 – 0.13	.005 – 0.015"	.005"	.003 – 0.010"			

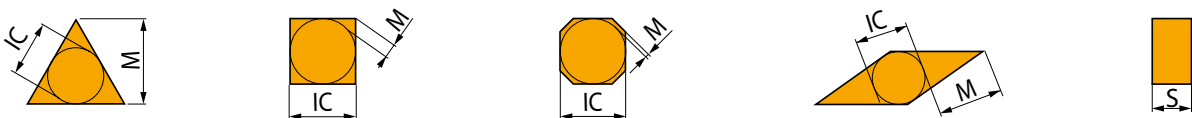

UÇLAR – ISO KODLAMA SİSTEMİ

5	6	7	8	9	10
22	04	08			
22	04	08	E	N	M
5	6	7	8	9	10
4	3	2			
4	3	2	E	N	M

5		5												
Kesici kenar uzunluğu														
d=IC		H	O	P	S	T	C	D	E	M	V	W	R	K
(mm)	(in)													
3.97	5/32"				03	06		04			06	02		
4.76	3/16"				04	08	04	05	04	04	08	L3		
5.56	7/32"				05	09	05	06	05	05	09	03		
6.35	1/4"	03	02	04	08	11	06	07	08	08	11	04	06	
7.94	5/16"	04	03	05	07	13	08	09	06	07	13	05	07	
9.525	3/8"	05	04	07	09	16	09	11	09	09	16	06	09	16
12.7	1/2"	07	05	09	12	22	12	15	13	12	22	08	12	
15.875	5/8"	09	06	11	15	27	16	19	16	15	27	10	15	
19.05	3/4"	11	07	13	19	33	19	23	19	19	33	13	19	
25.40	1"	14	10	18	25	44	25	31	26	25	44	17	25	
31.75	1 1/4"	18	13	23	31	54	32	38	32	31	54	21	31	

6		7	
Uç kalınlığı		Kesici kenar köşesi	
S		RE	
		(mm)	(")
00	0	0	0"
02	0.2	1/128"	
04	0.4	1/64"	
08	0.8	1/32"	
12	1.2	3/64"	
16	1.6	1/16"	
24	2.4	3/32"	
32	3.2	1/8"	
		Yuvarlak uçlar	
		d=I.C.	
		(")	00
		(mm)	M0

ANSI					
5		6		7	
İç teğet çapı		Uç kalınlığı		Kesici kenar köşesi	
Symbol		Symbol		Symbol	
d=I.C.		S		RE	
		(mm)		(mm)	
		(")		(")	
1	3.175	1	1.588	0	0
	1/8"		1/16"	0.2	0.099
1.2	3.969	1.2	1.984		1/256"
	5/32"		5/64"	0.5	0.198
1.5	4.763	1.5	2.381		1/128"
	3/16"		3/32"	1	0.397
1.8	5.556	2	3.175		1/64"
	7/32"		1/8"	2	0.794
2	6.350	2.5	3.969		1/32"
	1/4"		5/32"	3	1.191
2.5	7.938	3	4.763		3/64"
	5/16"		3/16"	4	1.588
3	9.525	3.5	5.556		1/16"
	3/8"		7/32"	5	1.984
4	12.700	4	6.350		5/64"
	1/2"		1/4"	6	2.381
5	15.875	5	7.938		3/32"
	5/8"		5/16"	7	2.778
6	19.050	6	9.525		7/64"
	3/4"		3/8"	8	3.175
7	22.225	7	11.113		1/8"
	7/8"		7/16"	10	3.969
8	25.400	8	12.700		5/32"
	1"		1/2"	12	4.763
10	31.750	9	14.288		3/16"
	5/4"		9/16"	14	5.556
12	38.100	10	15.875		7/32"
	6/4"		5/8"	16	6.350
					1/4"

8		8	
Kesme kenar tasarımı			
	Keskin kesme kenarlı		Yuvarlatılmış kesme kenarlı
	ahlı kesme kenarlı		Pahlı ve yuvarlatılmış kesme kenarlı
	Çift pahlı kesme kenarlı		Çift pahlı ve yuvarlatılmış kesme kenarlı
9		9	
Kesme yönü			
	Sağ kesme yönlü		Sağ kesme yönlü
	Sağ kesme yönlü		Sağ kesme yönlü
10		10	
Talaş kırıcı tipi			



DIŞ ÇAP TORNALAMA TAKIMLARI – ISO KODU İŞARETİ

Şaft takım	ISO	2	3	4	5	6	7	8	11	12	13
		P	C	L	N	R	- 32	25	L	12	- M
PSC	ISO	1	2	3	4	5	6	9	10	12	
		C4	- D	C	L	N	R	- 27	050	- 12	
Şaft takım	ANSI	2	3	4	5	6	7 & 8	12	11		
		D	C	L	N	R	- 16	4	D		

1		2		3				4			
Bağlantı boyutu		Sıkma tipi		Uç şekli				Yanaşma açısı			
	C		H	O	P	R	A	B	C	D	D
	D		S	T	C	D	E	F	G	H	J
	P		E	M	V	W	K	L	M	N	P
	M		L	A	B	K	Q	R	S	S	T
	S						U	V	W	X	Y
	X						Z				
G											
C	DCON MS										
C3	32										
C4	40										
C5	50										
C6	63										
C8	80										

5		6		7 & 8				11	
Serbest açı		Kesme yönü		Kesme kenar yüksekliği (")				Şaft boyu	
		R		Symbol	B (")	H (")			
N	B	L		05	5/16"	5/16"	D	60	
0°	5°	N		06	3/8"	3/8"	E	70	
				08	1/2"	1/2"	F	80	
				10	5/8"	5/8"	H	100	
				12	3/4"	3/4"	J	110	
				16	1"	1"	K	125	
				85	1"	1 1/4"	L	140	
				86	1"	1 1/2"	M	150	
				20	1 1/4"	1 1/4"	N	160	
				24	1 1/2"	1 1/2"	P	170	
				32	2"	2"	Q	180	
							R	200	
							S	250	
							T	300	
							U	350	
							V	400	
							W	450	
							X	Özel	
							Y	500	

7					
Kesme kenar yüksekliği (mm)					
08	10	12	16	20	25
32	38	40	45	50	60

8					
Şaft genişliği (mm)					
08	10	12	16	20	25
32	38	40	45	50	60

Kare şaftlar için, genişlik ve yükseklik inç olarak 16'lık sayılardır. Dikdörtgen şaftlar için ilk basamak genişlik inç olarak 8'lik sayılardır ve ikinci basamak yükseklik inç olarak 4'lük sayılardır.

9		10	
Fonksiyonel genişlik [mm]		Fonksiyonel uzunluk [mm]	



İÇ ÇAP TORNALAMA TAKIMLARI – ISO KODU İŞARETİ

ISO	15	16	17	-	2	3	4	5	6	12	-	14
	A	25	T	-	P	C	L	N	L	12	-	X
ANSI	15	16	17	-	2	3	4	5	6	12	-	
	A	16	T	-	D	C	L	N	L	4	-	

12		12												
		Kesici kenar uzunluğu												
d=İ.C.		H	O	P	S	T	C	D	E	M	V	W	R	K
(mm)	(")													
3.97					03	06		04			06	02		
	5/32"					1.2								
4.76					04	08	04	05	04	04	08	L3		
	3/16"					1.5								
5.56					05	09	05	06	05	05	09	03		
	7/32"					1.8								
6.35		03	02	04	08	11	06	07	08	08	11	04	06	
	1/4"					2								
7.94		04	03	05	07	13	08	09	06	07	13	05	07	
	5/16"					2.5								
9.525		05	04	07	09	16	09	11	09	09	16	06	09	16
	3/8"					3								
12.7		07	05	09	12	22	12	15	13	12	22	08	12	
	1/2"					4								
15.875		09	06	11	15	27	16	19	16	15	27	10	15	
	5/8"					5								
19.05		11	07	13	19	33	19	23	19	19	33	13	19	
	3/4"					6								
25.40		14	10	18	25	44	25	31	26	25	44	17	25	
	1"					8								
31.75		18	13	23	31	54	32	38	32	31	54	21	31	
	1 1/4"					10								

13	
Üretici kodlaması	
M	Şimli S tipi sıkma sistemi

14	
Üretici kodlaması	
X	Özel şaft tipi
.	
.	
93	Z= Özel yanaşma açılı
.	
.	

15		15	
Takım malzemesi			
S	Çelik şaft		
A	Soğutma suyu kanallı çelik şaft		
E	Soğutma suyu kanallı çelik başlıklı ve sert metal gövde		

16		16	
Şaft Ø [mm]		DCON MS [mm]	
		DCON MS (")	
08	8	03	.1875"
10	10	04	.250"
12	12	05	.3125"
16	16	06	.375"
20	20	08	.500"
25	25	10	.625"
32	32	12	.750"
40	40	16	1.000"
50	50	20	1.250"
60	60	24	1.500"
		32	2.000"

17		17	
Şaft boyu		LF [mm]	
		D	60
		E	70
		F	80
		H	100
		J	110
		K	125
		L	140
		M	150
		N	160
		P	170
		Q	180
		R	200
		S	250
		T	300
		U	350
		V	400
		W	450
		X	Özel
		Y	500

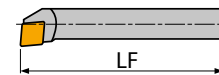

KARTUŞ

1	2	3	4	5	6	7
KH	P	C	L	N	R	25

TUTUCU

8	6	9	10	11
DKH	R	50	60	W

1	2	3	4
Kartuş	Sıkma tipi	Uç şekli	Yanaşma açısı
5 Serbest aç	C	S	A
AN	D	T	B
N	P	R	C
0°	M	W	D
C	S	L	E
7°	X	X	F
P	G	X	G
11°			H
6 Kesme yönü			J
R			K
L			L
N			M
			N
			P
			Q
			R
			S
			S
			T
			U
			V
			W
			X
			Y
			Z

7		Kesici kenar uzunluğu												
d = I.C.		H	O	P	S	T	C	D	E	M	V	W	R	K
(mm)	(")													
3.97	5/32"				03	06					06	02		
4.76	3/16"				04	08	04	05	04	04	08	L3		
5.56	7/32"				05	09	05	06	05	05	09	03		
6.35	1/4"	03	02	04	08	11	06	07	08	08	11	04	06	
7.94	5/16"	04	03	05	07	13	08	09	06	07	13	05	07	
9.525	3/8"	05	04	07	09	16	09	11	09	09	16	06	09	16
12.7	1/2"	07	05	09	12	22	12	15	13	12	22	08	12	
15.875	5/8"	09	06	11	15	27	16	19	16	15	27	10	15	
19.05	3/4"	11	07	13	19	33	19	23	19	19	33	13	19	
25.40	1"	14	10	18	25	44	25	31	26	25	44	17	25	
31.75	1 1/4"	18	13	23	31	54	32	38	32	31	54	21	31	

8
Kartuş kateri

9
Kesme kenar yüksekliği (mm)

08	10	12	16	20	25
32	40	50	60	70	80

10
Şaft genişliği (mm)

08	10	12	16	20	25
32	40	50	60	70	80

11
Şaft boyu

	LF (mm)
H	100
J	110
K	125
L	140
M	150
N	160
P	170
Q	180
R	200
S	250
T	300
U	350
V	400
W	450
X	Şifred.
Y	500

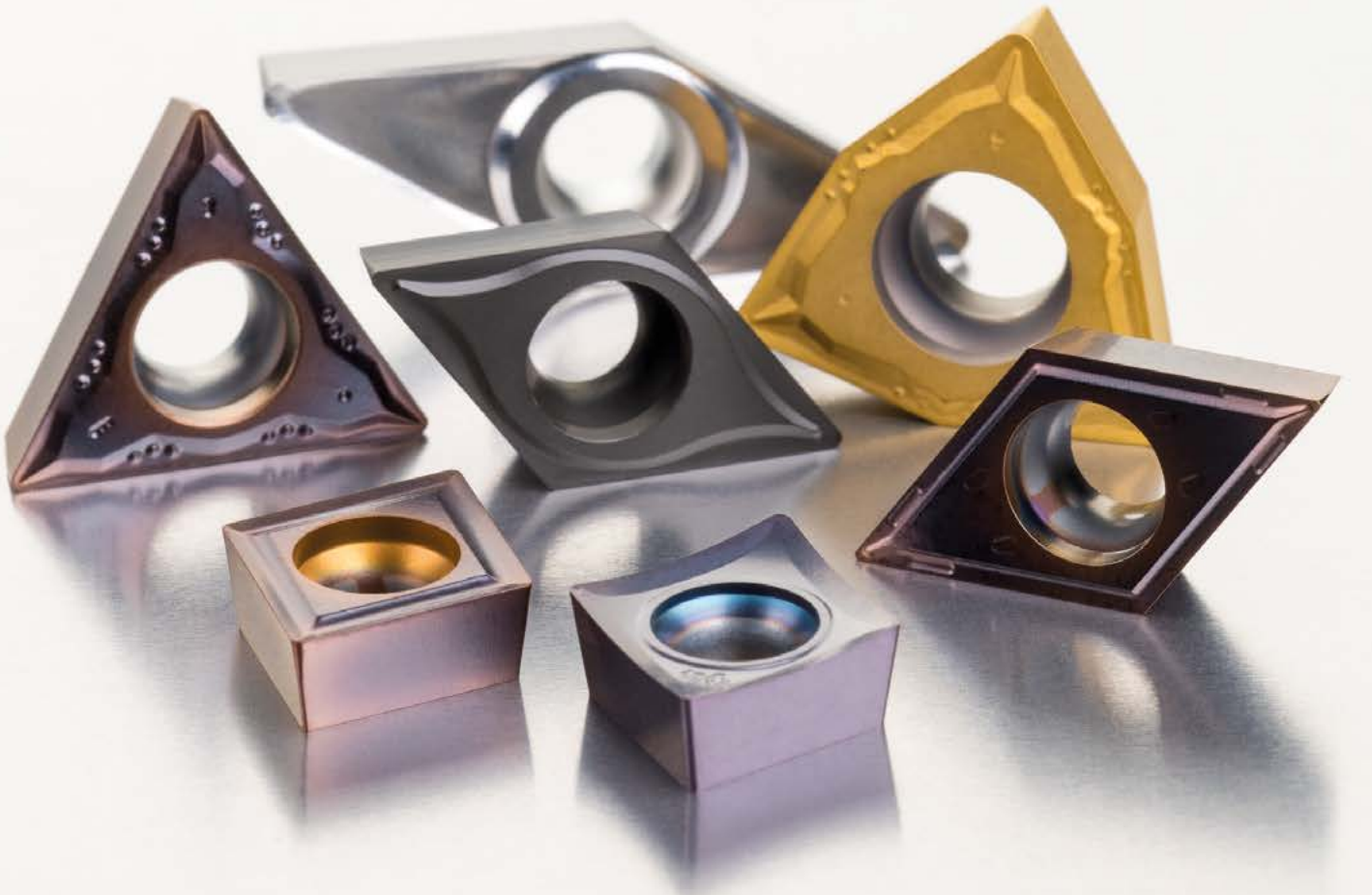

POZİTİF KESİCİ UÇLAR



CC

06 / 08 / 09 / 12

KARBÜR UÇLAR

CCGT



60

CCMT



62

CCMW



68

KARBÜR UÇLAR

CCGW CBN



69

DOĞRU BOYUTLA EŞLEŞTİRİN (örnek)

Kesici uç

Takım Tutucu

CCMT 120404E-UR

S32U-SCKCR 12-A

ISO TORNALAMA - DIŞ

SCAC(RL) EXT

90°

CC..

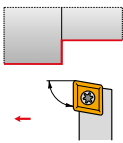
06
09
 08×08
16×16

70

60 – 69

SCBC(RL) EXT

75°

CC..

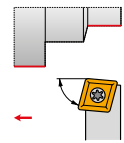
09
12
 12×12
25×25

71

60 – 69

SCDCR EXT

45°

CC..



06

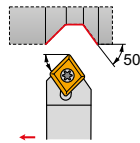

10×10

72

60 – 69

SCFC(RL) EXT

90°

CC..

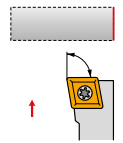
06
09
 08×08
16×16

73

60 – 69

SCLC(RL) EXT

95°

CC..

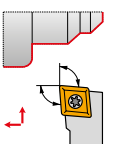
06
08
09
12
 08×08
25×25

74

60 – 69

C.-SCLC(RL) EXT **NEW**

95°

CC..

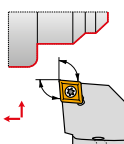
09
12
 C3
C5

75

60 – 69



CC

06 / 08 / 09 / 12

ISO TORNALAMA - İÇ

SCFC(RL) INT

90°

CC..

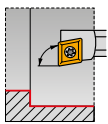

06

 $\frac{13}{16}$

76

60-69

SCKC(RL) INT

75°

CC..

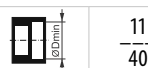
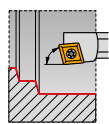
06
09
12
 $\frac{11}{40}$

77

60-69

SCLC(RL) INT

95°

CC..

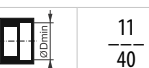
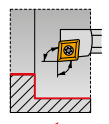
06
09
12
 $\frac{11}{40}$

78

60-69

SCXC(RL) INT

40°

CC..

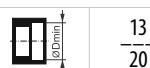
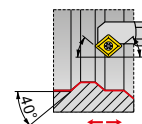

06

 $\frac{13}{20}$

80

60-69

C.-SCLC(RL) INT **NEW**

95°

CC..

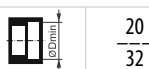
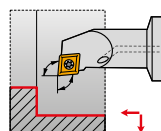

09

 $\frac{20}{32}$

81

60-69



CCGT



	IC	D1	L	S
	(mm)	(mm)	(mm)	(mm)
0602	6.350	2.80	6.40	2.38
0602-SF3	6.350	2.80	6.40	2.58
0803-AL	7.940	3.40	8.10	3.43
0803-SF3	7.940	3.40	8.10	3.43
09T3	9.525	4.40	9.70	3.97
09T3-SF3	9.525	4.40	9.70	4.22
1204	12.700	5.50	12.90	4.76
1204-SF3	12.700	5.50	12.90	5.01

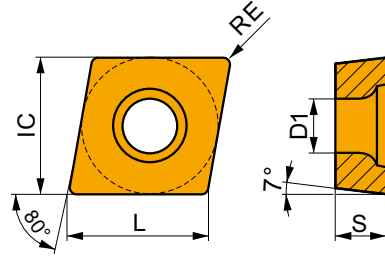

Kesme hızı (vc), ilerleme (f) ve kesme derinliği (ap) için uygunluk ve başlangıç değerleri. Daha ileri hesaplamalar için İşleme Hesaplayıcısı uygulamasına başvurun.

Product	RE	P			M			K			N			S			H		
		vc	f	ap	vc	f	ap	vc	f	ap	vc	f	ap	vc	f	ap	vc	f	ap
	(mm)	(m/min)	(mm/rev)	(mm)	(m/min)	(mm/rev)	(mm)	(m/min)	(mm/rev)	(mm)	(m/min)	(mm/rev)	(mm)	(m/min)	(mm/rev)	(mm)	(m/min)	(mm/rev)	(mm)



AL geometri, ince finişten kabaya, ve darbesizden hafif darbeli kesmeye kadar uygun, çok pozitif tasarım.

CCGT 060202F-AL	HF7	0.2	-	-	-	-	-	-	-	450	0.12	1.0	-	-	-	-	-	-
	T0315	0.2	-	-	-	-	-	-	-	645	0.12	1.0	-	-	-	-	-	-
CCGT 060204F-AL	HF7	0.4	-	-	-	-	-	-	-	360	0.24	1.0	-	-	-	-	-	-
	T0315	0.4	-	-	-	-	-	-	-	525	0.24	1.0	-	-	-	-	-	-
CCGT 080302F-AL	T0315	0.2	-	-	-	-	-	-	-	645	0.12	1.0	-	-	-	-	-	-
CCGT 080304F-AL	HF7	0.4	-	-	-	-	-	-	-	360	0.24	1.0	-	-	-	-	-	-
	T0315	0.4	-	-	-	-	-	-	-	525	0.24	1.0	-	-	-	-	-	-
CCGT 09T302F-AL	HF7	0.2	-	-	-	-	-	-	-	450	0.12	1.0	-	-	-	-	-	-
	T0315	0.2	-	-	-	-	-	-	-	645	0.12	1.0	-	-	-	-	-	-
CCGT 09T304F-AL	HF7	0.4	-	-	-	-	-	-	-	345	0.24	1.5	-	-	-	-	-	-
	T0315	0.4	-	-	-	-	-	-	-	495	0.24	1.5	-	-	-	-	-	-
CCGT 09T308F-AL	HF7	0.8	-	-	-	-	-	-	-	315	0.48	1.5	-	-	-	-	-	-
	T0315	0.8	-	-	-	-	-	-	-	450	0.48	1.5	-	-	-	-	-	-
CCGT 120404F-AL	HF7	0.4	-	-	-	-	-	-	-	330	0.24	2.4	-	-	-	-	-	-
	T0315	0.4	-	-	-	-	-	-	-	480	0.24	2.4	-	-	-	-	-	-
CCGT 120408F-AL	HF7	0.8	-	-	-	-	-	-	-	300	0.48	2.4	-	-	-	-	-	-
	T0315	0.8	-	-	-	-	-	-	-	435	0.48	2.4	-	-	-	-	-	-

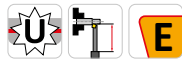
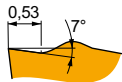

FF2 geometri, ince-finişten finiş işleme kadar için çok pozitif tasarım, darbesizden hafif darbeli işleme kadar uygun.

CCGT 09T302E-FF2	T7325	0.2	235	0.05	1.0	-	-	-	-	-	-	-	-	-	-	-	-	-
	T9325	0.2	345	0.05	1.0	-	-	-	325	0.05	1.0	-	-	-	-	-	-	-

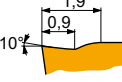

NF1 geometri, ince finişten ortaya kadar işlemek için pozitif tasarım, darbesiz kesim için uygun.

CCGT 060204E-NF1	H07	0.4	-	-	-	95	0.09	0.8	-	-	-	485	0.12	0.8	45	0.07	0.6	-	-	-
	T6310	0.4	180	0.10	0.8	125	0.09	0.8	-	-	-	540	0.12	0.8	50	0.07	0.6	35	0.15	1.0
	T7325	0.4	210	0.10	0.8	160	0.09	0.8	-	-	-	-	-	-	65	0.07	0.6	-	-	-
CCGT 060208E-NF1	T6310	0.8	205	0.12	0.8	145	0.11	0.8	-	-	-	615	0.14	0.8	60	0.11	0.6	40	0.15	1.0
	T7325	0.8	235	0.12	0.8	180	0.11	0.8	-	-	-	-	-	-	75	0.11	0.6	-	-	-
CCGT 09T304E-NF1	H07	0.4	-	-	-	90	0.09	1.2	-	-	-	470	0.12	1.2	45	0.07	1.0	-	-	-
	T6310	0.4	175	0.10	1.2	125	0.09	1.2	-	-	-	525	0.12	1.2	50	0.07	1.0	35	0.15	1.0
	T7325	0.4	200	0.10	1.2	155	0.09	1.2	-	-	-	-	-	-	65	0.07	1.0	-	-	-
CCGT 09T308E-NF1	T6310	0.8	190	0.14	1.2	135	0.13	1.2	-	-	-	570	0.17	1.2	55	0.13	1.0	35	0.15	1.0
	T7325	0.8	215	0.14	1.2	165	0.13	1.2	-	-	-	-	-	-	65	0.13	1.0	-	-	-



Kesme hızı (vc), ilerleme (f) ve kesme derinliği (ap) için uygunluk ve başlangıç değerleri. Daha ileri hesaplamalar için İşleme Hesaplayıcısı uygulamasına başvurun.

Product	RE (mm)	P			M			K			N			S			H		
		vc (m/min)	f (mm/rev)	ap (mm)	vc (m/min)	f (mm/rev)	ap (mm)	vc (m/min)	f (mm/rev)	ap (mm)	vc (m/min)	f (mm/rev)	ap (mm)	vc (m/min)	f (mm/rev)	ap (mm)	vc (m/min)	f (mm/rev)	ap (mm)

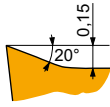
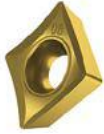

SF3 geometri, inceden finiş işleme kadar işlemek için çok pozitif tasarım, darbesiz kesim için uygun.

CCGT 060201E-SF3	T6310	0.1	200	0.05	0.5	140	0.05	0.5	160	0.05	0.5	600	0.06	0.5	60	0.04	0.4	40	0.15	1.0
CCGT 060202E-SF3	H07	0.2	-	-	-	120	0.05	0.8	190	0.05	0.8	605	0.06	0.8	60	0.04	0.6	-	-	-
	T6310	0.2	205	0.05	0.8	145	0.05	0.8	165	0.05	0.8	615	0.06	0.8	60	0.04	0.6	40	0.15	1.0
	T8315	0.2	215	0.05	0.8	125	0.05	0.8	200	0.05	0.8	645	0.06	0.8	50	0.04	0.6	40	0.15	1.0
CCGT 060204E-SF3	H07	0.4	-	-	-	95	0.09	0.8	150	0.10	0.8	485	0.12	0.8	45	0.07	0.6	-	-	-
	T6310	0.4	180	0.10	0.8	125	0.09	0.8	145	0.10	0.8	540	0.12	0.8	50	0.07	0.6	35	0.15	1.0
	T8315	0.4	190	0.10	0.8	110	0.09	0.8	180	0.10	0.8	570	0.12	0.8	45	0.07	0.6	35	0.15	1.0
CCGT 080302E-SF3	T6310	0.2	205	0.05	0.8	145	0.05	0.8	165	0.05	0.8	615	0.06	0.8	60	0.04	0.6	40	0.15	1.0
	T8315	0.2	215	0.05	0.8	125	0.05	0.8	200	0.05	0.8	645	0.06	0.8	50	0.04	0.6	40	0.15	1.0
CCGT 080304E-SF3	H07	0.4	-	-	-	95	0.09	1.0	150	0.10	1.0	485	0.12	1.0	45	0.07	0.8	-	-	-
	T6310	0.4	180	0.10	1.0	125	0.09	1.0	145	0.10	1.0	540	0.12	1.0	50	0.07	0.8	35	0.15	1.0
	T8315	0.4	190	0.10	1.0	110	0.09	1.0	180	0.10	1.0	570	0.12	1.0	45	0.07	0.8	35	0.15	1.0
CCGT 09T301E-SF3	T6310	0.1	200	0.05	0.5	140	0.05	0.5	160	0.05	0.5	600	0.06	0.5	60	0.04	0.4	40	0.15	1.0
CCGT 09T302E-SF3	H07	0.2	-	-	-	120	0.05	0.8	190	0.05	0.8	605	0.06	0.8	60	0.04	0.6	-	-	-
	T6310	0.2	205	0.05	0.8	145	0.05	0.8	165	0.05	0.8	615	0.06	0.8	60	0.04	0.6	40	0.15	1.0
	T8315	0.2	215	0.05	0.8	125	0.05	0.8	200	0.05	0.8	645	0.06	0.8	50	0.04	0.6	40	0.15	1.0
CCGT 09T304E-SF3	H07	0.4	-	-	-	95	0.09	1.0	150	0.10	1.0	485	0.12	1.0	45	0.07	0.8	-	-	-
	T6310	0.4	180	0.10	1.0	125	0.09	1.0	145	0.10	1.0	540	0.12	1.0	50	0.07	0.8	35	0.15	1.0
	T8315	0.4	190	0.10	1.0	110	0.09	1.0	180	0.10	1.0	570	0.12	1.0	45	0.07	0.8	35	0.15	1.0
CCGT 09T308E-SF3	H07	0.8	-	-	-	110	0.09	1.0	175	0.10	1.0	565	0.12	1.0	55	0.08	0.8	-	-	-
	T6310	0.8	210	0.10	1.0	150	0.09	1.0	165	0.10	1.0	630	0.12	1.0	60	0.08	0.8	40	0.15	1.0
	T8315	0.8	225	0.10	1.0	135	0.09	1.0	210	0.10	1.0	675	0.12	1.0	55	0.08	0.8	45	0.15	1.0
CCGT 120404E-SF3	T6310	0.4	180	0.10	1.0	125	0.09	1.0	145	0.10	1.0	540	0.12	1.0	50	0.07	0.8	35	0.15	1.0
CCGT 120408E-SF3	H07	0.8	-	-	-	105	0.12	1.0	165	0.12	1.0	525	0.14	1.0	50	0.11	0.8	-	-	-
	T6310	0.8	200	0.12	1.0	140	0.12	1.0	160	0.12	1.0	600	0.14	1.0	60	0.11	0.8	40	0.15	1.0
	T8315	0.8	210	0.12	1.0	125	0.12	1.0	195	0.12	1.0	630	0.14	1.0	50	0.11	0.8	40	0.15	1.0

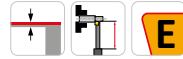

ER-SI geometri, çok pozitif sağ kesme yönlü tasarım, ince finişten yarı kaba işleme kadar, ve darbesiz kesim için uygun.

CCGT 060202ER-SI	T8330	0.2	215	0.10	0.8	125	0.09	0.8	200	0.10	0.8	-	-	-	50	0.08	0.6	-	-	-
	T8430	0.2	260	0.10	0.8	140	0.09	0.8	215	0.10	0.8	-	-	-	55	0.08	0.6	-	-	-
CCGT 060204ER-SI	T8315	0.4	225	0.12	0.8	135	0.11	0.8	210	0.12	0.8	-	-	-	55	0.10	0.6	-	-	-
	T8330	0.4	215	0.12	0.8	125	0.11	0.8	200	0.12	0.8	-	-	-	50	0.10	0.6	-	-	-
	T8430	0.4	260	0.12	0.8	140	0.11	0.8	215	0.12	0.8	-	-	-	55	0.10	0.6	-	-	-
CCGT 09T304ER-SI	T8315	0.4	205	0.17	0.8	120	0.15	0.8	190	0.17	0.8	-	-	-	50	0.15	0.6	-	-	-
	T8330	0.4	195	0.17	0.8	115	0.15	0.8	185	0.17	0.8	-	-	-	45	0.15	0.6	-	-	-
	T8430	0.4	230	0.17	0.8	125	0.15	0.8	185	0.17	0.8	-	-	-	45	0.15	0.6	-	-	-
CCGT 120408ER-SI	T8330	0.8	205	0.23	1.0	120	0.21	1.0	190	0.23	1.0	-	-	-	50	0.21	0.8	-	-	-
	T8430	0.8	230	0.24	1.0	125	0.22	1.0	185	0.24	1.0	-	-	-	45	0.22	0.8	-	-	-

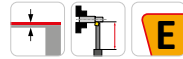

EL-SI geometri, çok pozitif sol kesme yönlü tasarım, ince finişten yarı kaba işleme kadar, ve darbesiz kesim için uygun.

CCGT 060202EL-SI	T8330	0.2	215	0.10	0.8	125	0.09	0.8	200	0.10	0.8	-	-	-	50	0.08	0.6	-	-	-
	T8430	0.2	260	0.10	0.8	140	0.09	0.8	215	0.10	0.8	-	-	-	55	0.08	0.6	-	-	-
CCGT 060204EL-SI	T8315	0.4	225	0.12	0.8	135	0.11	0.8	210	0.12	0.8	-	-	-	55	0.10	0.6	-	-	-
	T8330	0.4	215	0.12	0.8	125	0.11	0.8	200	0.12	0.8	-	-	-	50	0.10	0.6	-	-	-
	T8430	0.4	260	0.12	0.8	140	0.11	0.8	215	0.12	0.8	-	-	-	55	0.10	0.6	-	-	-
CCGT 09T304EL-SI	T8315	0.4	205	0.17	0.8	120	0.15	0.8	190	0.17	0.8	-	-	-	50	0.15	0.6	-	-	-
	T8330	0.4	195	0.17	0.8	115	0.15	0.8	185	0.17	0.8	-	-	-	45	0.15	0.6	-	-	-
	T8430	0.4	230	0.17	0.8	125	0.15	0.8	185	0.17	0.8	-	-	-	45	0.15	0.6	-	-	-
CCGT 120408EL-SI	T8330	0.8	205	0.23	1.0	120	0.21	1.0	190	0.23	1.0	-	-	-	50	0.21	0.8	-	-	-
	T8430	0.8	230	0.24	1.0	125	0.22	1.0	185	0.24	1.0	-	-	-	45	0.22	0.8	-	-	-



CCMT

	IC	D1	L	S
	(mm)	(mm)	(mm)	(mm)
0602	6.350	2.80	6.40	2.38
0803	7.940	3.40	8.10	3.18
09T3	9.525	4.40	9.70	3.97
1204	12.700	5.50	12.90	4.76

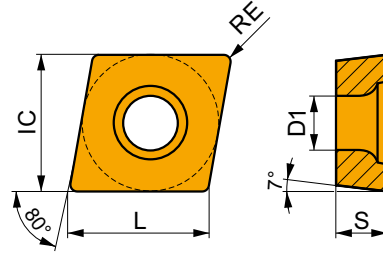

Kesme hızı (vc), ilerleme (f) ve kesme derinliği (ap) için uygunluk ve başlangıç değerleri. Daha ileri hesaplamalar için İşleme Hesaplayıcısı uygulamasına başvurun.

Product	RE	P			M			K			N			S			H		
		vc	f	ap	vc	f	ap	vc	f	ap	vc	f	ap	vc	f	ap	vc	f	ap
	(mm)	(m/min)	(mm/rev)	(mm)	(m/min)	(mm/rev)	(mm)	(m/min)	(mm/rev)	(mm)	(m/min)	(mm/rev)	(mm)	(m/min)	(mm/rev)	(mm)	(m/min)	(mm/rev)	(mm)

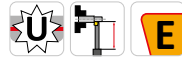
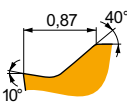

FF geometri, ince-finiş işleme için çok pozitif tasarım, darbesizden hafif darbeleri işlemeye kadar uygun.

CCMT 060202E-FF	T8315	0.2	195	0.10	1.0	115	0.09	1.0	-	-	-	-	-	-	-	-	-	-	-
	T8330	0.2	185	0.10	1.0	110	0.09	1.0	-	-	-	-	-	-	-	-	-	-	-
	T8430	0.2	230	0.10	1.0	125	0.09	1.0	-	-	-	-	-	-	-	-	-	-	-
	T9315	0.2	315	0.10	1.0	-	-	-	-	-	-	-	-	-	-	-	-	-	-
CCMT 060204E-FF	T8315	0.4	195	0.12	1.0	115	0.11	1.0	-	-	-	-	-	-	-	-	-	-	-
	T8330	0.4	185	0.12	1.0	110	0.11	1.0	-	-	-	-	-	-	-	-	-	-	-
	T8430	0.4	225	0.12	1.0	120	0.11	1.0	-	-	-	-	-	-	-	-	-	-	-
	T9315	0.4	310	0.12	1.0	-	-	-	-	-	-	-	-	-	-	-	-	-	-
CCMT 09T304E-FF	T8315	0.4	190	0.12	1.2	110	0.11	1.2	-	-	-	-	-	-	-	-	-	-	-
	T8330	0.4	185	0.12	1.2	110	0.11	1.2	-	-	-	-	-	-	-	-	-	-	-
	T8430	0.4	225	0.12	1.2	120	0.11	1.2	-	-	-	-	-	-	-	-	-	-	-
	T9315	0.4	300	0.12	1.2	-	-	-	-	-	-	-	-	-	-	-	-	-	-

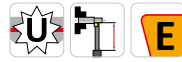
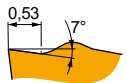

FF2 geometri, ince-finişten finişe işlemeye kadar için çok pozitif tasarım, darbesizden hafif darbeleri işlemeye kadar uygun.

CCMT 060202E-FF2	T7325	0.2	240	0.05	0.8	-	-	-	-	-	-	-	-	-	-	-	-	-	-
	T8330	0.2	205	0.05	0.8	190	0.05	0.8	-	-	-	-	-	-	-	-	-	-	-
	T8430	0.2	280	0.05	0.8	230	0.05	0.8	-	-	-	-	-	-	-	-	-	-	-
	T9315	0.2	390	0.05	0.8	370	0.05	0.8	-	-	-	-	-	-	-	-	-	-	-
	T9325	0.2	350	0.05	0.8	330	0.05	0.8	-	-	-	-	-	-	-	-	-	-	-
CCMT 060204E-FF2	TT010	0.2	345	0.05	0.5	-	-	-	-	-	-	-	-	-	-	-	-	-	-
	T7325	0.4	190	0.12	1.0	-	-	-	-	-	-	-	-	-	-	-	-	-	-
	T8330	0.4	165	0.12	1.0	155	0.12	1.0	-	-	-	-	-	-	-	-	-	-	-
	T8430	0.4	205	0.12	1.0	170	0.12	1.0	-	-	-	-	-	-	-	-	-	-	-
	T9315	0.4	280	0.12	1.0	265	0.12	1.0	-	-	-	-	-	-	-	-	-	-	-
	T9325	0.4	255	0.12	1.0	240	0.12	1.0	-	-	-	-	-	-	-	-	-	-	-
CCMT 080302E-FF2	TT010	0.4	215	0.12	1.0	-	-	-	-	-	-	-	-	-	-	-	-	-	-
	T7325	0.2	240	0.05	0.8	-	-	-	-	-	-	-	-	-	-	-	-	-	-
	T8330	0.2	205	0.05	0.8	190	0.05	0.8	-	-	-	-	-	-	-	-	-	-	-
	T8430	0.2	280	0.05	0.8	230	0.05	0.8	-	-	-	-	-	-	-	-	-	-	-
	T9325	0.2	350	0.05	0.8	330	0.05	0.8	-	-	-	-	-	-	-	-	-	-	-
CCMT 080304E-FF2	TT010	0.2	345	0.05	0.5	-	-	-	-	-	-	-	-	-	-	-	-	-	-
	T7325	0.4	190	0.12	1.0	-	-	-	-	-	-	-	-	-	-	-	-	-	-
	T8330	0.4	165	0.12	1.0	155	0.12	1.0	-	-	-	-	-	-	-	-	-	-	-
	T8430	0.4	205	0.12	1.0	170	0.12	1.0	-	-	-	-	-	-	-	-	-	-	-
	T9325	0.4	255	0.12	1.0	240	0.12	1.0	-	-	-	-	-	-	-	-	-	-	-
TT010	0.4	350	0.06	0.5	-	-	-	-	-	-	-	-	-	-	-	-	-	-	-



Kesme hızı (vc), ilerleme (f) ve kesme derinliği (ap) için uygunluk ve başlangıç değerleri. Daha ileri hesaplamalar için İşleme Hesaplayıcısı uygulamasına başvurun.

Product	RE (mm)	P			M			K			N			S			H		
		vc (m/min)	f (mm/rev)	ap (mm)	vc (m/min)	f (mm/rev)	ap (mm)	vc (m/min)	f (mm/rev)	ap (mm)	vc (m/min)	f (mm/rev)	ap (mm)	vc (m/min)	f (mm/rev)	ap (mm)	vc (m/min)	f (mm/rev)	ap (mm)

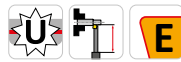
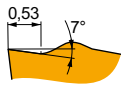

FF2 geometri, ince-finişten finişe işlemeye kadar için çok pozitif tasarım, darbesizden hafif darbeli işlemeye kadar uygun.

CCMT 080308E-FF2	T7325	0.8	205	0.17	1.0	-	-	-	-	-	-	-	-	-	-	-	-	-
	T8330	0.8	180	0.17	1.0	-	-	-	170	0.17	1.0	-	-	-	-	-	-	-
	T8430	0.8	210	0.17	1.0	-	-	-	175	0.17	1.0	-	-	-	-	-	-	-
	T9325	0.8	260	0.17	1.0	-	-	-	245	0.17	1.0	-	-	-	-	-	-	-
CCMT 09T304E-FF2	T7325	0.4	190	0.12	1.2	-	-	-	-	-	-	-	-	-	-	-	-	-
	T8330	0.4	165	0.12	1.2	-	-	-	155	0.12	1.2	-	-	-	-	-	-	-
	T8430	0.4	200	0.12	1.2	-	-	-	165	0.12	1.2	-	-	-	-	-	-	-
	T9315	0.4	275	0.12	1.2	-	-	-	260	0.12	1.2	-	-	-	-	-	-	-
	T9325	0.4	250	0.12	1.2	-	-	-	235	0.12	1.2	-	-	-	-	-	-	-
	T9335	0.4	215	0.12	1.2	-	-	-	-	-	-	-	-	-	-	-	-	-
CCMT 09T308E-FF2	TT010	0.4	350	0.06	0.5	-	-	-	-	-	-	-	-	-	-	-	-	-
	T7325	0.8	205	0.17	1.2	-	-	-	-	-	-	-	-	-	-	-	-	-
	T8330	0.8	175	0.17	1.2	-	-	-	165	0.17	1.2	-	-	-	-	-	-	-
	T8430	0.8	205	0.17	1.2	-	-	-	170	0.17	1.2	-	-	-	-	-	-	-
	T9315	0.8	285	0.17	1.2	-	-	-	270	0.17	1.2	-	-	-	-	-	-	-
	T9325	0.8	255	0.17	1.2	-	-	-	240	0.17	1.2	-	-	-	-	-	-	-

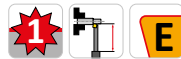

FM geometri, finişten yarı kaba işlemeye, ve darbesizden hafif darbeli kesmeye kadar uygun.

CCMT 060202E-FM	T7325	0.2	210	0.10	1.0	160	0.09	1.0	-	-	-	-	-	-	-	-	-
	T7335	0.2	210	0.10	1.0	160	0.09	1.0	-	-	-	-	-	-	-	-	-
	T8315	0.2	195	0.10	1.0	115	0.09	1.0	185	0.10	1.0	585	0.12	1.0	-	-	-
	T8330	0.2	185	0.10	1.0	110	0.09	1.0	175	0.10	1.0	555	0.12	1.0	-	-	-
	T8430	0.2	230	0.10	1.0	125	0.09	1.0	185	0.10	1.0	630	0.12	1.0	-	-	-
	T9315	0.2	315	0.10	1.0	-	-	-	295	0.10	1.0	-	-	-	-	-	-
CCMT 060204E-FM	T9325	0.2	285	0.10	1.0	170	0.09	1.0	270	0.10	1.0	-	-	-	-	-	-
	T7325	0.4	200	0.15	1.0	155	0.15	1.0	-	-	-	-	-	-	-	-	-
	T7335	0.4	195	0.15	1.0	150	0.15	1.0	-	-	-	-	-	-	-	-	-
	T8315	0.4	185	0.15	1.0	110	0.14	1.0	175	0.15	1.0	555	0.18	1.0	-	-	-
	T8330	0.4	170	0.15	1.0	100	0.14	1.0	160	0.15	1.0	510	0.18	1.0	-	-	-
	T8430	0.4	205	0.15	1.0	110	0.14	1.0	170	0.15	1.0	570	0.18	1.0	-	-	-
CCMT 060208E-FM	T9315	0.4	285	0.15	1.0	-	-	-	270	0.15	1.0	-	-	-	-	-	-
	T9325	0.4	250	0.15	1.0	150	0.15	1.0	235	0.15	1.0	-	-	-	-	-	-
	T7325	0.8	220	0.20	1.0	170	0.18	1.0	-	-	-	-	-	-	-	-	-
	T8330	0.8	190	0.20	1.0	110	0.18	1.0	180	0.20	1.0	570	0.24	1.0	-	-	-
	T8430	0.8	220	0.20	1.0	120	0.18	1.0	180	0.20	1.0	600	0.24	1.0	-	-	-
	T9315	0.8	300	0.20	1.0	-	-	-	285	0.20	1.0	-	-	-	-	-	-
CCMT 09T302E-FM	T9325	0.8	265	0.20	1.0	155	0.18	1.0	250	0.20	1.0	-	-	-	-	-	-
	T7325	0.2	205	0.10	1.2	155	0.09	1.2	-	-	-	-	-	-	-	-	-
	T7335	0.2	205	0.10	1.2	155	0.09	1.2	-	-	-	-	-	-	-	-	-
	T8315	0.2	190	0.10	1.2	110	0.09	1.2	180	0.10	1.2	570	0.12	1.2	-	-	-
	T8330	0.2	180	0.10	1.2	105	0.09	1.2	170	0.10	1.2	540	0.12	1.2	-	-	-
	T8430	0.2	225	0.10	1.2	120	0.09	1.2	185	0.10	1.2	615	0.12	1.2	-	-	-
CCMT 09T304E-FM	T9315	0.2	310	0.10	1.2	-	-	-	290	0.10	1.2	-	-	-	-	-	-
	T9325	0.2	275	0.10	1.2	165	0.09	1.2	260	0.10	1.2	-	-	-	-	-	-
	T7325	0.4	195	0.15	1.2	150	0.15	1.2	-	-	-	-	-	-	-	-	-
	T7335	0.4	190	0.15	1.2	145	0.15	1.2	-	-	-	-	-	-	-	-	-
	T8315	0.4	180	0.15	1.2	105	0.14	1.2	170	0.15	1.2	540	0.18	1.2	-	-	-
	T8330	0.4	170	0.15	1.2	100	0.14	1.2	160	0.15	1.2	510	0.18	1.2	-	-	-
CCMT 09T304E-FM	T8430	0.4	200	0.15	1.2	110	0.14	1.2	165	0.15	1.2	555	0.18	1.2	-	-	-
	T9315	0.4	275	0.15	1.2	-	-	-	260	0.15	1.2	-	-	-	-	-	-
	T9325	0.4	245	0.15	1.2	145	0.15	1.2	230	0.15	1.2	-	-	-	-	-	-



Kesme hızı (vc), ilerleme (f) ve kesme derinliği (ap) için uygunluk ve başlangıç değerleri. Daha ileri hesaplamalar için İşleme Hesaplayıcısı uygulamasına başvurun.

Product	RE (mm)	P			M			K			N			S			H		
		vc (m/min)	f (mm/rev)	ap (mm)	vc (m/min)	f (mm/rev)	ap (mm)	vc (m/min)	f (mm/rev)	ap (mm)	vc (m/min)	f (mm/rev)	ap (mm)	vc (m/min)	f (mm/rev)	ap (mm)	vc (m/min)	f (mm/rev)	ap (mm)

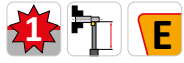
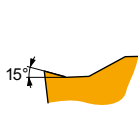

FM geometri, finiştan yarı kaba işleme, ve darbesizden hafif darbeli kesmeye kadar uygun.

CCMT 09T308E-FM	T7325	0.8	215	0.20	1.2	165	0.18	1.2	-	-	-	-	-	-	-	-	-	-	
	T7335	0.8	205	0.20	1.2	155	0.18	1.2	-	-	-	-	-	-	-	-	-	-	
	T8315	0.8	195	0.20	1.2	115	0.18	1.2	185	0.20	1.2	585	0.24	1.2	-	-	-	-	
	T8330	0.8	185	0.20	1.2	110	0.18	1.2	175	0.20	1.2	555	0.24	1.2	-	-	-	-	
	T8430	0.8	210	0.20	1.2	115	0.18	1.2	175	0.20	1.2	585	0.24	1.2	-	-	-	-	
	T9315	0.8	290	0.20	1.2	-	-	-	275	0.20	1.2	-	-	-	-	-	-	-	-
	T9325	0.8	260	0.20	1.2	155	0.18	1.2	245	0.20	1.2	-	-	-	-	-	-	-	
CCMT 120404E-FM	T7325	0.4	190	0.15	1.7	145	0.15	1.7	-	-	-	-	-	-	-	-	-	-	
	T7335	0.4	185	0.15	1.7	140	0.15	1.7	-	-	-	-	-	-	-	-	-	-	
	T8315	0.4	170	0.15	1.7	100	0.14	1.7	160	0.15	1.7	510	0.18	1.7	-	-	-	-	
	T8330	0.4	165	0.15	1.7	95	0.14	1.7	155	0.15	1.7	495	0.18	1.7	-	-	-	-	
	T8430	0.4	195	0.15	1.7	105	0.14	1.7	160	0.15	1.7	540	0.18	1.7	-	-	-	-	
	T9315	0.4	265	0.15	1.7	-	-	-	250	0.15	1.7	-	-	-	-	-	-	-	
	T9325	0.4	240	0.15	1.7	140	0.15	1.7	225	0.15	1.7	-	-	-	-	-	-	-	
CCMT 120408E-FM	T7325	0.8	205	0.20	1.7	155	0.18	1.7	-	-	-	-	-	-	-	-	-	-	
	T7335	0.8	200	0.20	1.7	155	0.18	1.7	-	-	-	-	-	-	-	-	-	-	
	T8315	0.8	190	0.20	1.7	110	0.18	1.7	180	0.20	1.7	570	0.24	1.7	-	-	-	-	
	T8330	0.8	180	0.20	1.7	105	0.18	1.7	170	0.20	1.7	540	0.24	1.7	-	-	-	-	
	T8430	0.8	205	0.20	1.7	110	0.18	1.7	170	0.20	1.7	570	0.24	1.7	-	-	-	-	
	T9315	0.8	280	0.20	1.7	-	-	-	265	0.20	1.7	-	-	-	-	-	-	-	
	T9325	0.8	250	0.20	1.7	150	0.18	1.7	235	0.20	1.7	-	-	-	-	-	-	-	
CCMT 120412E-FM	T8330	1.2	175	0.27	1.7	105	0.24	1.7	165	0.27	1.7	525	0.32	1.7	-	-	-	-	
	T8430	1.2	190	0.27	1.7	105	0.24	1.7	155	0.27	1.7	525	0.32	1.7	-	-	-	-	
	T9325	1.2	235	0.27	1.7	140	0.24	1.7	220	0.27	1.7	-	-	-	-	-	-		

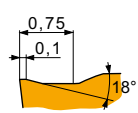

FM2 geometri, finiştan orta işleme kadar, ve darbesizden darbeli kesmeye kadar uygun.

CCMT 080304E-FM2	T8330	0.4	165	0.12	1.0	95	0.11	1.0	155	0.12	1.0	-	-	-	-	-	-
	T8430	0.4	205	0.12	1.0	110	0.11	1.0	170	0.12	1.0	-	-	-	-	-	-
	T9315	0.4	280	0.12	1.0	-	-	-	265	0.12	1.0	-	-	-	-	-	-
	T9325	0.4	255	0.12	1.0	150	0.11	1.0	240	0.12	1.0	-	-	-	-	-	-
	T9335	0.4	215	0.12	1.0	125	0.11	1.0	-	-	-	-	-	-	-	-	-
CCMT 080308E-FM2	T8330	0.8	180	0.17	1.0	105	0.15	1.0	170	0.17	1.0	-	-	-	-	-	-
	T8430	0.8	210	0.17	1.0	115	0.15	1.0	175	0.17	1.0	-	-	-	-	-	-
	T9325	0.8	260	0.17	1.0	155	0.15	1.0	245	0.17	1.0	-	-	-	-	-	-
	T9335	0.8	225	0.17	1.0	135	0.15	1.0	-	-	-	-	-	-	-	-	-
CCMT 09T304E-FM2	T6310	0.4	165	0.12	1.0	115	0.11	1.0	130	0.12	1.0	-	-	-	-	-	-
	T8330	0.4	165	0.12	1.0	95	0.11	1.0	155	0.12	1.0	-	-	-	-	-	-
	T8430	0.4	205	0.12	1.0	110	0.11	1.0	170	0.12	1.0	-	-	-	-	-	-
	T9315	0.4	280	0.12	1.0	-	-	-	265	0.12	1.0	-	-	-	-	-	-
	T9325	0.4	255	0.12	1.0	150	0.11	1.0	240	0.12	1.0	-	-	-	-	-	-
CCMT 09T308E-FM2	T6310	0.8	180	0.17	1.0	125	0.15	1.0	145	0.17	1.0	-	-	-	-	-	-
	T7325	0.8	205	0.17	1.0	155	0.15	1.0	-	-	-	-	-	-	-	-	-
	T8330	0.8	180	0.17	1.0	105	0.15	1.0	170	0.17	1.0	-	-	-	-	-	-
	T8430	0.8	210	0.17	1.0	115	0.15	1.0	175	0.17	1.0	-	-	-	-	-	-
	T9315	0.8	290	0.17	1.0	-	-	-	275	0.17	1.0	-	-	-	-	-	-
	T9325	0.8	260	0.17	1.0	155	0.15	1.0	245	0.17	1.0	-	-	-	-	-	-
CCMT 120408E-FM2	T7325	0.8	190	0.20	1.5	145	0.18	1.5	-	-	-	-	-	-	-	-	-
	T8330	0.8	165	0.20	1.5	95	0.18	1.5	155	0.20	1.5	-	-	-	-	-	-
	T8430	0.8	190	0.20	1.5	105	0.18	1.5	155	0.20	1.5	-	-	-	-	-	-
	T9325	0.8	235	0.20	1.5	140	0.18	1.5	220	0.20	1.5	-	-	-	-	-	-
	T9335	0.8	200	0.20	1.5	120	0.18	1.5	-	-	-	-	-	-	-	-	-



Kesme hızı (vc), ilerleme (f) ve kesme derinliği (ap) için uygunluk ve başlangıç değerleri. Daha ileri hesaplamalar için İşleme Hesaplayıcısı uygulamasına başvurun.

Product	RE (mm)	P			M			K			N			S			H		
		vc (m/min)	f (mm/rev)	ap (mm)	vc (m/min)	f (mm/rev)	ap (mm)	vc (m/min)	f (mm/rev)	ap (mm)	vc (m/min)	f (mm/rev)	ap (mm)	vc (m/min)	f (mm/rev)	ap (mm)	vc (m/min)	f (mm/rev)	ap (mm)

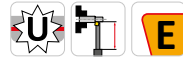
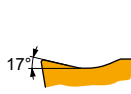

NF1 geometri, ince finiştan yarı kabaya kadar işlemek için pozitif tasarım, darbesiz kesim için uygun.

CCMT 060202E-NF2	T6310	0.2	✓	170	0.10	0.8	■	120	0.09	0.8	✓	135	0.10	0.8	■	510	0.12	0.8	■	50	0.08	0.6	-	-	-	
	T7325	0.2	✓	195	0.10	0.8	■	150	0.09	0.8	-	-	-	-	-	-	-	-	■	60	0.08	0.6	-	-	-	
	T8330	0.2	✓	170	0.10	0.8	■	100	0.09	0.8	✓	160	0.10	0.8	■	510	0.12	0.8	■	40	0.08	0.6	-	-	-	
	T8430	0.2	✓	210	0.10	0.8	■	115	0.09	0.8	✓	175	0.10	0.8	■	585	0.12	0.8	■	45	0.08	0.6	-	-	-	
	T9325	0.2	✓	260	0.10	0.8	■	155	0.09	0.8	✓	245	0.10	0.8	-	-	-	-	-	■	55	0.08	0.6	-	-	-
CCMT 060204E-NF2	H07	0.4	-	-	-	-	■	85	0.11	0.8	✓	140	0.12	0.8	■	445	0.14	0.8	■	45	0.11	0.6	-	-	-	
	T6310	0.4	✓	170	0.12	0.8	■	120	0.11	0.8	✓	135	0.12	0.8	■	510	0.14	0.8	■	50	0.11	0.6	-	-	-	
	T7325	0.4	✓	200	0.12	0.8	■	155	0.11	0.8	-	-	-	-	-	-	-	-	■	65	0.11	0.6	-	-	-	
	T8330	0.4	✓	170	0.12	0.8	■	100	0.11	0.8	✓	160	0.12	0.8	■	510	0.14	0.8	■	40	0.11	0.6	-	-	-	
	T8430	0.4	✓	205	0.12	0.8	■	110	0.11	0.8	✓	170	0.12	0.8	■	570	0.14	0.8	■	45	0.11	0.6	-	-	-	
	T9315	0.4	✓	290	0.12	0.8	-	-	-	-	✓	275	0.12	0.8	-	-	-	-	-	-	-	-	-	-	-	
	T9325	0.4	✓	255	0.12	0.8	■	150	0.11	0.8	✓	240	0.12	0.8	-	-	-	-	-	■	55	0.11	0.6	-	-	-
	T9335	0.4	✓	220	0.12	0.8	■	130	0.11	0.8	-	-	-	-	-	-	-	-	-	■	45	0.11	0.6	-	-	-
CCMT 080304E-NF2	T5315	0.4	✓	280	0.12	1.0	-	-	-	✓	265	0.12	1.0	-	-	-	-	-	-	-	-	-	-	-	-	
	T7325	0.4	✓	190	0.12	1.0	■	145	0.11	1.0	-	-	-	-	-	-	-	-	■	60	0.11	0.8	-	-	-	
	T7335	0.4	✓	190	0.12	1.0	■	145	0.11	1.0	-	-	-	-	-	-	-	-	■	60	0.11	0.8	-	-	-	
	T9315	0.4	✓	280	0.12	1.0	-	-	-	-	✓	265	0.12	1.0	-	-	-	-	-	-	-	-	-	-	-	
	T9325	0.4	✓	255	0.12	1.0	■	150	0.11	1.0	✓	240	0.12	1.0	-	-	-	-	-	■	55	0.11	0.8	-	-	-
CCMT 080308E-NF2	H07	0.8	-	-	-	-	■	95	0.13	1.2	✓	150	0.14	1.2	■	485	0.17	1.2	■	45	0.13	1.0	-	-	-	
	T5315	0.8	✓	295	0.17	1.0	-	-	-	✓	280	0.17	1.0	-	-	-	-	-	-	-	-	-	-	-	-	
	T7325	0.8	✓	205	0.17	1.0	■	155	0.15	1.0	-	-	-	-	-	-	-	-	■	65	0.14	0.8	-	-	-	
	T7335	0.8	✓	205	0.17	1.0	■	155	0.15	1.0	-	-	-	-	-	-	-	-	■	65	0.14	0.8	-	-	-	
	T9325	0.8	✓	260	0.17	1.0	■	155	0.15	1.0	✓	245	0.17	1.0	-	-	-	-	-	■	55	0.14	0.8	-	-	-
CCMT 09T304E-NF2	H07	0.4	-	-	-	-	■	85	0.11	1.2	✓	135	0.12	1.2	■	430	0.14	1.2	■	40	0.11	1.0	-	-	-	
	T6310	0.4	✓	165	0.12	1.2	■	115	0.11	1.2	✓	130	0.12	1.2	■	495	0.14	1.2	■	45	0.11	1.0	-	-	-	
	T7325	0.4	✓	190	0.12	1.2	■	145	0.11	1.2	-	-	-	-	-	-	-	-	■	60	0.11	1.0	-	-	-	
	T8330	0.4	✓	165	0.12	1.2	■	95	0.11	1.2	✓	155	0.12	1.2	■	495	0.14	1.2	■	40	0.11	1.0	-	-	-	
	T8430	0.4	✓	200	0.12	1.2	■	110	0.11	1.2	✓	165	0.12	1.2	■	555	0.14	1.2	■	40	0.11	1.0	-	-	-	
	T9315	0.4	✓	275	0.12	1.2	-	-	-	-	✓	260	0.12	1.2	-	-	-	-	-	-	-	-	-	-	-	
	T9325	0.4	✓	250	0.12	1.2	■	150	0.11	1.2	✓	235	0.12	1.2	-	-	-	-	-	■	55	0.11	1.0	-	-	-
	T9335	0.4	✓	215	0.12	1.2	■	125	0.11	1.2	-	-	-	-	-	-	-	-	-	■	45	0.11	1.0	-	-	-
CCMT 09T308E-NF2	H07	0.8	-	-	-	-	■	95	0.13	1.2	✓	150	0.14	1.2	■	485	0.17	1.2	■	45	0.13	1.0	-	-	-	
	T6310	0.8	✓	190	0.14	1.2	■	135	0.13	1.2	✓	150	0.14	1.2	■	570	0.17	1.2	■	55	0.13	1.0	-	-	-	
	T7325	0.8	✓	215	0.14	1.2	■	165	0.13	1.2	-	-	-	-	-	-	-	-	■	65	0.13	1.0	-	-	-	
	T8330	0.8	✓	190	0.14	1.2	■	110	0.13	1.2	✓	180	0.14	1.2	■	570	0.17	1.2	■	45	0.13	1.0	-	-	-	
	T8430	0.8	✓	225	0.14	1.2	■	120	0.13	1.2	✓	185	0.14	1.2	■	615	0.17	1.2	■	45	0.13	1.0	-	-	-	
	T9315	0.8	✓	310	0.14	1.2	-	-	-	-	✓	290	0.14	1.2	-	-	-	-	-	-	-	-	-	-	-	
	T9325	0.8	✓	275	0.14	1.2	■	165	0.13	1.2	✓	260	0.14	1.2	-	-	-	-	-	■	60	0.13	1.0	-	-	-
	T9335	0.8	✓	235	0.14	1.2	■	140	0.13	1.2	-	-	-	-	-	-	-	-	-	■	50	0.13	1.0	-	-	-



I.C.	R
6,35	1,0
9,525	1,5
12,7	2,5



RF geometri, yarı kabadan kaba işlemeye kadar, ve darbesizden darbeli kesime kadar uygun.

CCMT 060202E-RF	T7335	0.2	✓	150	0.15	1.0	■	115	0.14	1.0	-	-	-	-	-	-	-	-	-	-	-	-	-	-	
CCMT 060204E-RF	T5315	0.4	✓	235	0.15	1.0	-	-	-	■	220	0.15	1.0	-	-	-	-	-	-	■	45	0.15	1.0	-	-
	T7335	0.4	✓	160	0.15	1.0	■	120	0.15	1.0	-	-	-	-	-	-	-	-	-	-	-	-	-	-	
	T9325	0.4	■	205	0.15	1.0	■	120	0.15	1.0	✓	190	0.15	1.0	-	-	-	-	-	-	-	-	-	-	
CCMT 09T304E-RF	T7335	0.4	✓	135	0.20	1.5	■	105	0.18	1.5	-	-	-	-	-	-	-	-	-	-	-	-	-	-	
	T9325	0.4	■	175	0.20	1.5	■	105	0.18	1.5	✓	165	0.20	1.5	-	-	-	-	-	-	-	-	-	-	
CCMT 09T308E-RF	T5315	0.8	✓	245	0.20	1.5	-	-	-	■	230	0.20	1.5	-	-	-	-	-	-	■	45	0.15	1.0	-	-
	T7335	0.8	✓	165	0.20	1.5	■	125	0.18	1.5	-	-	-	-	-	-	-	-	-	-	-	-	-	-	
	T9325	0.8	■	210	0.20	1.5	■	125	0.18	1.5	✓	195	0.20	1.5	-	-	-	-	-	-	-	-	-	-	
CCMT 120408E-RF	T5315	0.8	✓	230	0.22	2.2	-	-	-	■	215	0.22	2.2	-	-	-	-	-	-	■	45	0.15	1.0	-	-
	T7335	0.8	✓	150	0.22	2.2	■	115	0.22	2.2	-	-	-	-	-	-	-	-	-	-	-	-	-	-	
	T9325	0.8	■	195	0.22	2.2	■	115	0.22	2.2	✓	185	0.22	2.2	-	-	-	-	-	-	-	-	-	-	



Kesme hızı (vc), ilerleme (f) ve kesme derinliği (ap) için uygunluk ve başlangıç değerleri. Daha ileri hesaplamalar için İşleme Hesaplayıcısı uygulamasına başvurun.

Product	RE (mm)	P			M			K			N			S			H		
		vc (m/min)	f (mm/rev)	ap (mm)	vc (m/min)	f (mm/rev)	ap (mm)	vc (m/min)	f (mm/rev)	ap (mm)	vc (m/min)	f (mm/rev)	ap (mm)	vc (m/min)	f (mm/rev)	ap (mm)	vc (m/min)	f (mm/rev)	ap (mm)

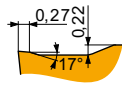
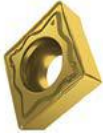

RM geometri, yarı kabadan kaba işlemeye kadar, ve darbesizden darbeli kesime kadar uygun.

CCMT 09T304E-RM	T5305	0.4	260	0.27	2.2	-	-	-	245	0.27	2.2	-	-	-	-	-	-	50	0.15	1.0
	T5315	0.4	230	0.27	2.2	-	-	-	215	0.27	2.2	-	-	-	-	-	-	45	0.15	1.0
	T7335	0.4	155	0.27	2.2	120	0.24	2.2	-	-	-	50	0.19	1.8	-	-	-	-	-	-
	T8330	0.4	140	0.27	2.2	80	0.24	2.2	130	0.27	2.2	-	-	-	35	0.19	1.8	25	0.15	1.0
	T8430	0.4	150	0.27	2.2	80	0.24	2.2	125	0.27	2.2	-	-	-	30	0.19	1.8	25	0.15	1.0
	T9315	0.4	215	0.27	2.2	-	-	-	200	0.27	2.2	-	-	-	-	-	-	40	0.15	1.0
	T9325	0.4	190	0.27	2.2	110	0.24	2.2	180	0.27	2.2	-	-	-	40	0.19	1.8	-	-	-
CCMT 09T308E-RM	T5305	0.8	290	0.30	2.2	-	-	-	275	0.30	2.2	-	-	-	-	-	-	55	0.15	1.0
	T5315	0.8	265	0.30	2.2	-	-	-	250	0.30	2.2	-	-	-	-	-	-	50	0.15	1.0
	T7335	0.8	175	0.30	2.2	135	0.27	2.2	-	-	-	55	0.24	1.8	-	-	-	-	-	
	T8330	0.8	165	0.30	2.2	95	0.27	2.2	155	0.30	2.2	-	-	-	40	0.24	1.8	30	0.15	1.0
	T8430	0.8	180	0.30	2.2	95	0.27	2.2	145	0.30	2.2	-	-	-	35	0.24	1.8	30	0.15	1.0
	T9315	0.8	240	0.30	2.2	-	-	-	225	0.30	2.2	-	-	-	-	-	-	45	0.15	1.0
	T9325	0.8	215	0.30	2.2	125	0.27	2.2	200	0.30	2.2	-	-	-	45	0.24	1.8	-	-	-
CCMT 120408E-RM	T5305	0.8	290	0.30	2.7	-	-	-	275	0.30	2.7	-	-	-	-	-	-	55	0.15	1.0
	T5315	0.8	260	0.30	2.7	-	-	-	245	0.30	2.7	-	-	-	-	-	-	50	0.15	1.0
	T7335	0.8	175	0.30	2.7	135	0.27	2.7	-	-	-	55	0.24	2.2	-	-	-	-	-	
	T8330	0.8	160	0.30	2.7	95	0.27	2.7	150	0.30	2.7	-	-	-	40	0.24	2.2	30	0.15	1.0
	T8430	0.8	175	0.30	2.7	95	0.27	2.7	140	0.30	2.7	-	-	-	35	0.24	2.2	30	0.15	1.0
	T9315	0.8	235	0.30	2.7	-	-	-	220	0.30	2.7	-	-	-	-	-	-	45	0.15	1.0
	T9325	0.8	210	0.30	2.7	125	0.27	2.7	195	0.30	2.7	-	-	-	45	0.24	2.2	-	-	-
CCMT 120412E-RM	T8330	1.2	165	0.33	2.7	95	0.30	2.7	155	0.33	2.7	-	-	-	40	0.23	2.2	30	0.15	1.0
	T8430	1.2	180	0.33	2.7	95	0.30	2.7	145	0.33	2.7	-	-	-	35	0.23	2.2	30	0.15	1.0
	T9315	1.2	235	0.33	2.7	-	-	-	220	0.33	2.7	-	-	-	-	-	-	45	0.15	1.0
	T9325	1.2	215	0.33	2.7	125	0.30	2.7	200	0.33	2.7	-	-	-	45	0.23	2.2	-	-	-

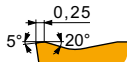

RM3 geometri, yarı kabadan kaba işlemeye kadar, ve darbesizden darbeli kesime kadar uygun.

CCMT 120404E-RM3	T7325	0.4	140	0.25	2.5	105	0.25	2.5	-	-	-	-	-	-	-	-	-	-	-	
	T9315	0.4	190	0.25	2.5	-	-	-	180	0.25	2.5	-	-	-	-	-	-	35	0.15	1.0
	T9325	0.4	165	0.25	2.5	95	0.25	2.5	155	0.25	2.5	-	-	-	-	-	-	-	-	
CCMT 120408E-RM3	T6310	0.8	145	0.27	2.5	100	0.27	2.5	115	0.27	2.5	-	-	-	-	-	-	25	0.15	1.0
	T7325	0.8	165	0.27	2.5	125	0.27	2.5	-	-	-	-	-	-	-	-	-	-	-	
	T9315	0.8	215	0.27	2.5	-	-	-	200	0.27	2.5	-	-	-	-	-	-	40	0.15	1.0
	T9325	0.8	195	0.27	2.5	115	0.27	2.5	185	0.27	2.5	-	-	-	-	-	-	-	-	
CCMT 120412E-RM3	T7325	1.2	170	0.30	2.5	130	0.27	2.5	-	-	-	-	-	-	-	-	-	-	-	
	T9315	1.2	220	0.30	2.5	-	-	-	205	0.30	2.5	-	-	-	-	-	-	40	0.15	1.0

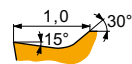

UR geometri, inceden finişe kadar işleme için, ve darbesiz ve hafif darbeli kesim.

CCMT 060202E-UR	T7325	0.2	185	0.10	0.8	140	0.09	0.8	-	-	-	-	-	-	-	-	-	-	-	
	T7335	0.2	185	0.10	0.8	140	0.09	0.8	-	-	-	-	-	-	-	-	-	-	-	
	T8315	0.2	170	0.10	0.8	100	0.09	0.8	160	0.10	0.8	-	-	-	-	-	-	-	-	
	T8330	0.2	160	0.10	0.8	95	0.09	0.8	150	0.10	0.8	-	-	-	-	-	-	-	-	
	T8430	0.2	200	0.10	0.8	110	0.09	0.8	165	0.10	0.8	-	-	-	-	-	-	-	-	
	T9315	0.2	275	0.10	0.8	-	-	-	260	0.10	0.8	-	-	-	-	-	-	-	-	-
	T9325	0.2	250	0.10	0.8	150	0.09	0.8	235	0.10	0.8	-	-	-	-	-	-	-	-	
	TT310	0.2	275	0.10	0.5	165	0.09	0.5	-	-	-	-	-	-	-	-	-	-	-	



Kesme hızı (vc), ilerleme (f) ve kesme derinliği (ap) için uygunluk ve başlangıç değerleri. Daha ileri hesaplamalar için İşleme Hesaplayıcısı uygulamasına başvurun.

Product	RE (mm)	P			M			K			N			S			H		
		vc (m/min)	f (mm/rev)	ap (mm)	vc (m/min)	f (mm/rev)	ap (mm)	vc (m/min)	f (mm/rev)	ap (mm)	vc (m/min)	f (mm/rev)	ap (mm)	vc (m/min)	f (mm/rev)	ap (mm)	vc (m/min)	f (mm/rev)	ap (mm)

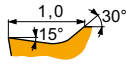

UR geometri, inceden finişe kadar işleme için, ve darbesiz ve hafif darbeleri kesim.

CCMT 060204E-UR	T5315	0.4	245	0.15	1.0	-	-	-	230	0.15	1.0	-	-	-	-	-	-	-	-	
	T7325	0.4	170	0.15	1.0	130	0.15	1.0	-	-	-	-	-	-	-	-	-	-	-	
	T7335	0.4	170	0.15	1.0	130	0.15	1.0	-	-	-	-	-	-	-	-	-	-	-	
	T8315	0.4	160	0.15	1.0	95	0.14	1.0	150	0.15	1.0	-	-	-	-	-	-	-	-	
	T8330	0.4	150	0.15	1.0	90	0.14	1.0	140	0.15	1.0	-	-	-	-	-	-	-	-	
	T8430	0.4	175	0.15	1.0	95	0.14	1.0	140	0.15	1.0	-	-	-	-	-	-	-	-	-
	T9315	0.4	245	0.15	1.0	-	-	-	230	0.15	1.0	-	-	-	-	-	-	-	-	-
	T9325	0.4	215	0.15	1.0	125	0.15	1.0	200	0.15	1.0	-	-	-	-	-	-	-	-	-
	TT310	0.4	255	0.15	0.5	150	0.14	0.5	-	-	-	-	-	-	-	-	-	-	-	-
	CCMT 060208E-UR	T5315	0.8	270	0.20	1.0	-	-	-	255	0.20	1.0	-	-	-	-	-	-	-	-
T7325		0.8	190	0.20	1.0	145	0.18	1.0	-	-	-	-	-	-	-	-	-	-	-	
T8330		0.8	165	0.20	1.0	95	0.18	1.0	155	0.20	1.0	-	-	-	-	-	-	-	-	
T8430		0.8	185	0.20	1.0	100	0.18	1.0	150	0.20	1.0	-	-	-	-	-	-	-	-	
T9315		0.8	255	0.20	1.0	-	-	-	240	0.20	1.0	-	-	-	-	-	-	-	-	-
CCMT 09T302E-UR	T6310	0.2	160	0.10	1.0	115	0.09	1.0	125	0.10	1.0	-	-	-	-	-	-	-	-	
	T8430	0.2	195	0.10	1.0	105	0.09	1.0	160	0.10	1.0	-	-	-	-	-	-	-	-	
	TT310	0.2	255	0.10	1.0	150	0.09	1.0	-	-	-	-	-	-	-	-	-	-	-	
CCMT 09T304E-UR	T5315	0.4	245	0.15	1.2	-	-	-	230	0.15	1.2	-	-	-	-	-	-	-	-	
	T7325	0.4	170	0.15	1.2	130	0.15	1.2	-	-	-	-	-	-	-	-	-	-	-	
	T7335	0.4	165	0.15	1.2	125	0.15	1.2	-	-	-	-	-	-	-	-	-	-	-	
	T8315	0.4	155	0.15	1.2	90	0.14	1.2	145	0.15	1.2	-	-	-	-	-	-	-	-	
	T8330	0.4	150	0.15	1.2	90	0.14	1.2	140	0.15	1.2	-	-	-	-	-	-	-	-	
	T8430	0.4	175	0.15	1.2	95	0.14	1.2	140	0.15	1.2	-	-	-	-	-	-	-	-	
	T9310	0.4	265	0.15	1.2	-	-	-	250	0.15	1.2	-	-	-	-	-	-	-	-	
	T9315	0.4	235	0.15	1.2	-	-	-	220	0.15	1.2	-	-	-	-	-	-	-	-	
	T9325	0.4	215	0.15	1.2	125	0.15	1.2	200	0.15	1.2	-	-	-	-	-	-	-	-	
	TT310	0.4	235	0.15	1.2	140	0.14	1.2	-	-	-	-	-	-	-	-	-	-	-	
CCMT 09T308E-UR	T5315	0.8	265	0.20	1.2	-	-	-	250	0.20	1.2	-	-	-	-	-	-	-	-	
	T7325	0.8	185	0.20	1.2	140	0.18	1.2	-	-	-	-	-	-	-	-	-	-	-	
	T7335	0.8	175	0.20	1.2	135	0.18	1.2	-	-	-	-	-	-	-	-	-	-	-	
	T8315	0.8	170	0.20	1.2	100	0.18	1.2	160	0.20	1.2	-	-	-	-	-	-	-	-	
	T8330	0.8	160	0.20	1.2	95	0.18	1.2	150	0.20	1.2	-	-	-	-	-	-	-	-	
	T8430	0.8	185	0.20	1.2	100	0.18	1.2	150	0.20	1.2	-	-	-	-	-	-	-	-	
	T9310	0.8	280	0.20	1.2	-	-	-	265	0.20	1.2	-	-	-	-	-	-	-	-	
	T9315	0.8	250	0.20	1.2	-	-	-	235	0.20	1.2	-	-	-	-	-	-	-	-	
	T9325	0.8	225	0.20	1.2	135	0.18	1.2	210	0.20	1.2	-	-	-	-	-	-	-	-	
	TT310	0.8	255	0.20	1.2	150	0.18	1.2	-	-	-	-	-	-	-	-	-	-	-	
CCMT 120404E-UR	T5315	0.4	235	0.15	1.7	-	-	-	220	0.15	1.7	-	-	-	-	-	-	-	-	
	T7325	0.4	160	0.15	1.7	120	0.15	1.7	-	-	-	-	-	-	-	-	-	-	-	
	T8330	0.4	140	0.15	1.7	80	0.14	1.7	130	0.15	1.7	-	-	-	-	-	-	-	-	
	T8430	0.4	170	0.15	1.7	90	0.14	1.7	135	0.15	1.7	-	-	-	-	-	-	-	-	
	T9315	0.4	230	0.15	1.7	-	-	-	215	0.15	1.7	-	-	-	-	-	-	-	-	
CCMT 120408E-UR	T5315	0.8	255	0.20	1.7	-	-	-	240	0.20	1.7	-	-	-	-	-	-	-	-	
	T7325	0.8	175	0.20	1.7	135	0.18	1.7	-	-	-	-	-	-	-	-	-	-	-	
	T7335	0.8	170	0.20	1.7	130	0.18	1.7	-	-	-	-	-	-	-	-	-	-	-	
	T8330	0.8	155	0.20	1.7	90	0.18	1.7	145	0.20	1.7	-	-	-	-	-	-	-	-	
	T8430	0.8	180	0.20	1.7	95	0.18	1.7	145	0.20	1.7	-	-	-	-	-	-	-	-	
	T9315	0.8	240	0.20	1.7	-	-	-	225	0.20	1.7	-	-	-	-	-	-	-	-	
	T9325	0.8	215	0.20	1.7	125	0.18	1.7	200	0.20	1.7	-	-	-	-	-	-	-	-	
	CCMT 120412E-UR	T5315	1.2	240	0.27	1.7	-	-	-	225	0.27	1.7	-	-	-	-	-	-	-	-
		T7325	1.2	170	0.27	1.7	130	0.24	1.7	-	-	-	-	-	-	-	-	-	-	-
		T8430	1.2	165	0.27	1.7	90	0.24	1.7	135	0.27	1.7	-	-	-	-	-	-	-	-
T9315		1.2	225	0.27	1.7	-	-	-	210	0.27	1.7	-	-	-	-	-	-	-	-	
T9325		1.2	205	0.27	1.7	120	0.24	1.7	190	0.27	1.7	-	-	-	-	-	-	-	-	



Kesme hızı (vc), ilerleme (f) ve kesme derinliği (ap) için uygunluk ve başlangıç değerleri. Daha ileri hesaplamalar için İşleme Hesaplayıcısı uygulamasına başvurun.

Product	RE (mm)	P			M			K			N			S			H		
		vc (m/min)	f (mm/rev)	ap (mm)	vc (m/min)	f (mm/rev)	ap (mm)	vc (m/min)	f (mm/rev)	ap (mm)	vc (m/min)	f (mm/rev)	ap (mm)	vc (m/min)	f (mm/rev)	ap (mm)	vc (m/min)	f (mm/rev)	ap (mm)

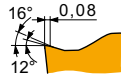
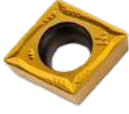

W-FM wiper geometri, inceden finişe kadar işleme, yüksek ilerleme hızları ve iyileştirilmiş yüzey finışı için.

CCMT 060204W-FM	T7325	0.4	165	0.30	0.8	125	0.27	0.8	-	-	-	-	-	-	-	-	-	-
	T8430	0.4	165	0.30	0.8	90	0.27	0.8	135	0.30	0.8	-	-	-	-	-	-	-
	T9315	0.4	215	0.30	0.8	-	-	-	200	0.30	0.8	-	-	-	-	-	-	-
	T9325	0.4	190	0.30	0.8	110	0.27	0.8	180	0.30	0.8	-	-	-	-	-	-	-
CCMT 09T304W-FM	T7325	0.4	165	0.30	0.8	125	0.27	0.8	-	-	-	-	-	-	-	-	-	-
	T8330	0.4	145	0.30	0.8	85	0.27	0.8	135	0.30	0.8	-	-	-	-	-	-	-
	T8430	0.4	165	0.30	0.8	90	0.27	0.8	135	0.30	0.8	-	-	-	-	-	-	-
	T9315	0.4	215	0.30	0.8	-	-	-	200	0.30	0.8	-	-	-	-	-	-	-
CCMT 09T308W-FM	T9325	0.4	190	0.30	0.8	110	0.27	0.8	180	0.30	0.8	-	-	-	-	-	-	-
	T8330	0.8	155	0.40	1.0	90	0.36	1.0	145	0.40	1.0	-	-	-	-	-	-	-
	T8430	0.8	170	0.40	1.0	90	0.36	1.0	135	0.40	1.0	-	-	-	-	-	-	-
	T9315	0.8	220	0.40	1.0	-	-	-	205	0.40	1.0	-	-	-	-	-	-	-
T9325	0.8	200	0.40	1.0	120	0.36	1.0	190	0.40	1.0	-	-	-	-	-	-	-	

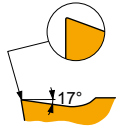
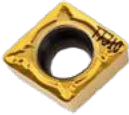

W-UR wiper geometri, finışten kabaya kadar işleme, yüksek ilerleme hızları ve iyileştirilmiş yüzey finışı için.

CCMT 060204W-UR	TT310	0.4	255	0.15	0.5	150	0.14	0.5	-	-	-	-	-	-	-	-	-	-
CCMT 09T308W-UR	TT310	0.8	255	0.20	1.2	150	0.18	1.2	-	-	-	-	-	-	-	-	-	-

CCMW

PRAMET

	IC (mm)	D1 (mm)	L (mm)	S (mm)
0602	6.350	2.80	6.40	2.38
09T3	9.525	4.40	9.70	3.97
1204	12.700	5.50	12.90	4.76

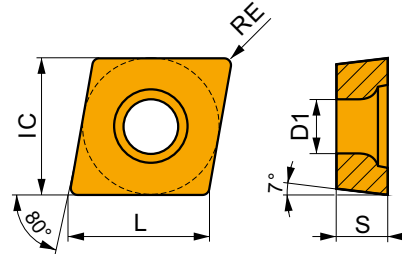

Kesme hızı (vc), ilerleme (f) ve kesme derinliği (ap) için uygunluk ve başlangıç değerleri. Daha ileri hesaplamalar için İşleme Hesaplayıcısı uygulamasına başvurun.

Product	RE (mm)	P			M			K			N			S			H		
		vc (m/min)	f (mm/rev)	ap (mm)	vc (m/min)	f (mm/rev)	ap (mm)	vc (m/min)	f (mm/rev)	ap (mm)	vc (m/min)	f (mm/rev)	ap (mm)	vc (m/min)	f (mm/rev)	ap (mm)	vc (m/min)	f (mm/rev)	ap (mm)

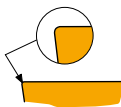

İnce finışten yarı kaba işleme kadar ve darbesizden hafif darbeli kesmeye kadar uygun.

CCMW 060202	T5305	0.2	-	-	-	-	-	-	230	0.08	2.0	-	-	-	-	-	45	0.15	1.0
	T6310	0.2	-	-	-	-	-	-	100	0.08	2.0	-	-	-	-	-	25	0.15	1.0
CCMW 060204	T5305	0.4	-	-	-	-	-	-	230	0.10	2.0	-	-	-	-	-	45	0.15	1.0
	T5315	0.4	-	-	-	-	-	-	195	0.10	2.0	-	-	-	-	-	40	0.15	1.0
	T6310	0.4	-	-	-	-	-	-	95	0.10	2.0	-	-	-	-	-	20	0.15	1.0
CCMW 09T304	T5305	0.4	-	-	-	-	-	-	215	0.10	3.0	-	-	-	-	-	45	0.15	1.0
	T5315	0.4	-	-	-	-	-	-	190	0.10	3.0	-	-	-	-	-	40	0.15	1.0
	T6310	0.4	-	-	-	-	-	-	95	0.10	3.0	-	-	-	-	-	20	0.15	1.0
CCMW 09T308	T5305	0.8	-	-	-	-	-	-	200	0.20	3.0	-	-	-	-	-	40	0.15	1.0
	T5315	0.8	-	-	-	-	-	-	180	0.20	3.0	-	-	-	-	-	35	0.15	1.0
	T6310	0.8	-	-	-	-	-	-	90	0.20	3.0	-	-	-	-	-	20	0.15	1.0



Kesme hızı (vc), ilerleme (f) ve kesme derinliği (ap) için uygunluk ve başlangıç değerleri. Daha ileri hesaplamalar için İşleme Hesaplayıcısı uygulamasına başvurun.

Product	RE (mm)	P			M			K			N			S			H		
		vc (m/min)	f (mm/rev)	ap (mm)	vc (m/min)	f (mm/rev)	ap (mm)	vc (m/min)	f (mm/rev)	ap (mm)	vc (m/min)	f (mm/rev)	ap (mm)	vc (m/min)	f (mm/rev)	ap (mm)	vc (m/min)	f (mm/rev)	ap (mm)
	0.4	T5305	—	—	—	—	—	—	—	—	—	—	—	—	—	—	—	—	—
		T5315	—	—	—	—	—	—	—	—	—	—	—	—	—	—	—	—	—
		T6310	—	—	—	—	—	—	—	—	—	—	—	—	—	—	—	—	—
CCMW 120408	0.8	T5305	—	—	—	—	—	—	—	—	—	—	—	—	—	—	—	—	—
		T5315	—	—	—	—	—	—	—	—	—	—	—	—	—	—	—	—	—
		T6310	—	—	—	—	—	—	—	—	—	—	—	—	—	—	—	—	—



İnce finişten yarı kaba işleme kadar ve darbesizden hafif darbeli kesmeye kadar uygun.



CCGW CBN

PRAMET

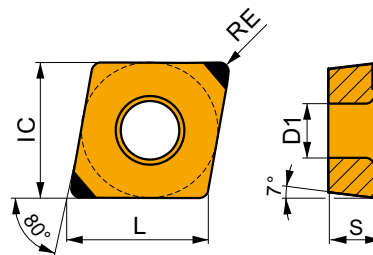
	IC (mm)	D1 (mm)	L (mm)	S (mm)
0602	6.350	2.80	6.50	2.38
09T3	9.525	4.50	9.70	3.97



Kesme hızı (vc), ilerleme (f) ve kesme derinliği (ap) için uygunluk ve başlangıç değerleri. Daha ileri hesaplamalar için İşleme Hesaplayıcısı uygulamasına başvurun.

Product	RE (mm)	P			M			K			N			S			H		
		vc (m/min)	f (mm/rev)	ap (mm)	vc (m/min)	f (mm/rev)	ap (mm)	vc (m/min)	f (mm/rev)	ap (mm)	vc (m/min)	f (mm/rev)	ap (mm)	vc (m/min)	f (mm/rev)	ap (mm)	vc (m/min)	f (mm/rev)	ap (mm)
	0.4	TB310	—	—	—	—	—	—	—	—	—	—	—	—	—	—	—	—	—
		CCGW 09T304E-B	—	—	—	—	—	—	—	—	—	—	—	—	—	—	—	—	—
	0.4	TB310	—	—	—	—	—	—	—	—	—	—	—	—	—	—	—	—	—
		CCGW 09T304S01020B	—	—	—	—	—	—	—	—	—	—	—	—	—	—	—	—	—



Finiş işleme için.



Finiş işleme için.



SCAC(RL) EXT

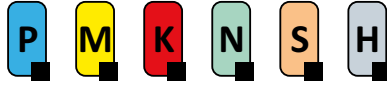

PRAMET

S



CC.. Uç için Vida Sıkmalı 90° Açılı Dış Kater

Vida sıkmalı Sağ/Sol 90° dış kater. Pozitif CC.. 06 veya 09 uçlarla çap, konik ve pah tornalama için uygundur. 08x08-16x16mm şaft ölçülerinde bulunur. Gövde uzun takım ömrü için işlem görmüştür.

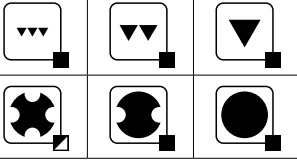
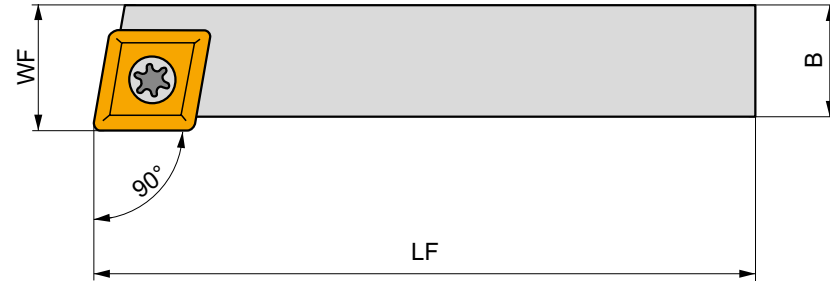

Product	H (mm)	B (mm)	HF (mm)	WF (mm)	LF (mm)	LAMS (°)	GAMO (°)	kg	GI041	GI045
R SCACR 0808 D 06	8	8	8	8.5	60	0	0	0.04	GI045	S07
R SCACR 1010 E 06	10	10	10	10.5	70	0	0	0.09	GI045	S07
R SCACR 1212 F 09	12	12	12	12.5	80	0	0	0.12	GI041	S04
R SCACR 1616 H 09	16	16	16	16.5	100	0	0	0.22	GI041	S04
L SCACL 0808 D 06	8	8	8	8.5	60	0	0	0.07	GI045	S07
L SCACL 1010 E 06	10	10	10	10.5	70	0	0	0.06	GI045	S07
L SCACL 1212 F 09	12	12	12	12.5	80	0	0	0.12	GI041	S04
L SCACL 1616 H 09	16	16	16	16.5	100	0	0	0.22	GI041	S04



GI041
GI045

CC.. 09T3..
CC.. 0602..



S04
S07

US 3510-T15P
US 2506-T07P

3.0
0.9

M 3.5
M 2.5

10.6
6.3

FLAG T15P
FLAG T07P



SCBC(RL) EXT



PRAMET

S

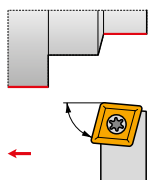

CC.. Uç için Vida Sıklı 75° Açılı Dış Kater

Vida sıklı Sağ/Sol 75° dış kater. Pozitif CC.. 09 veya 12 uçlarla çap ve pah tornalama için uygundur. 12x12-25x25mm shaft ölçülerinde bulunur. Gövde uzun takım ömrü için işlem görmüştür.

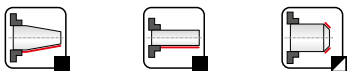
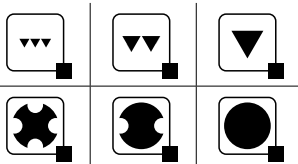
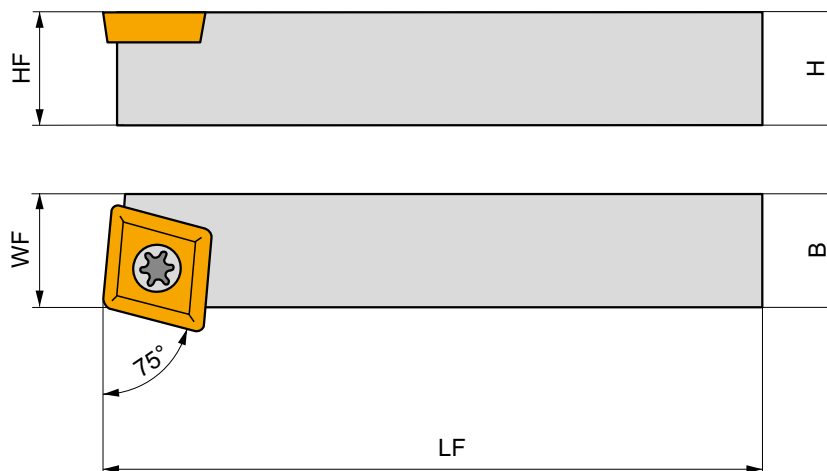

Product	H	B	HF	WF	LF	LAMS	GAMO	kg	GI011	GI041
	(mm)	(mm)	(mm)	(mm)	(mm)	(°)	(°)			
R SCBCR 1212 F 09	12	12	12	11	80	0	0	0.10	GI041	S08
SCBCR 1616 H 09	16	16	16	13	100	0	0	0.20	GI041	S08
SCBCR 2020 K 12-M-A	20	20	20	17	125	0	0	0.45	GI011	SC20
SCBCR 2525 M 12-M-A	25	25	25	22	150	0	0	0.61	GI011	SC20
L SCBCL 1212 F 09	12	12	12	11	80	0	0	0.10	GI041	S08
SCBCL 1616 H 09	16	16	16	13	100	0	0	0.22	GI041	S08
SCBCL 2020 K 12-M-A	20	20	20	17	125	0	0	0.43	GI011	SC20
SCBCL 2525 M 12-M-A	25	25	25	22	150	0	0	0.75	GI011	SC20



GI011

CC.. 1204..

GI041

CC.. 09T3..



SC20

US 5012-T15P

5.0

M 5

12.2

SCN 120304

MS 5008

FLAG T15P

HXK 5

S08

US 3510-T15P

3.0

M 3.5

10.6

-

-

FLAG T15P

-



SCDCR EXT

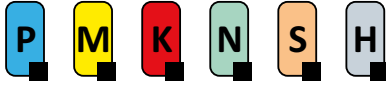

PRAMET

S



CC.. Uç için Vida Sıkmalı 45° Açılı Dış Kater

Vida sıkmalı nötr dış kater. Pozitif CC.. 06 uçlarla çap, kopya, konik ve pah tornalama için uygundur. Sadece 10mm mevcuttur. Gövde uzun takım ömrü için işlem görmüştür.

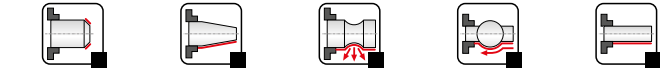
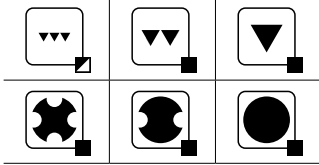
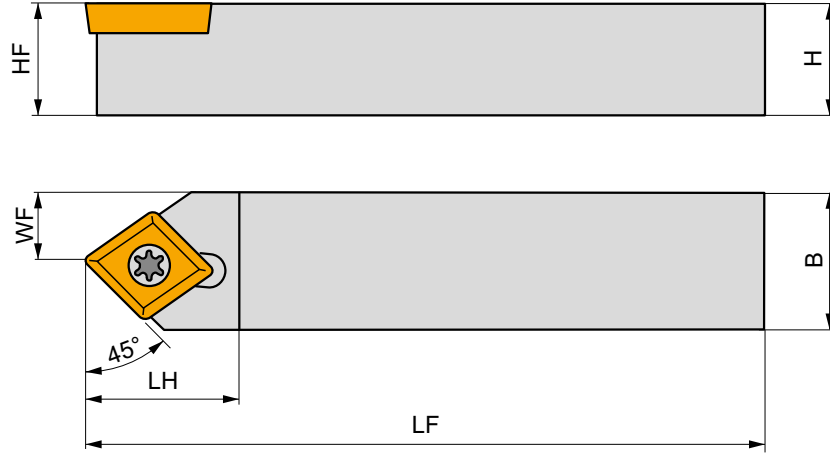
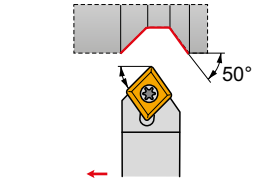

Product	H	B	HF	WF	LF	LH	LAMS	GAMO	kg	GI045	SC21
	(mm)	(mm)	(mm)	(mm)	(mm)	(mm)	(°)	(°)			
R SCDCR 1010 E 06	10	10	10	5.11	70	11	0	0	0.06	GI045	SC21

GI045	CC..0602..
-------	------------

SC21	5513 020-03	0.8	M 2.5	6.5	PT-8001
------	-------------	-----	-------	-----	---------



SCFC(RL) EXT



PRAMET

S



CC.. Uç için Vida Sıkmalı 90° Açılı Dış Kater

Vida sıkmalı Sağ/Sol 90° dış kater. Pozitif CC.. 06 veya 09 uçlarla çap, alın, konik ve pah tormalama için uygundur. 08x08-16x16mm shaft ölçülerinde bulunur. Gövde uzun takım ömrü için işlem görmüştür.

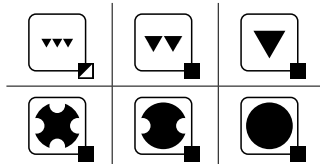
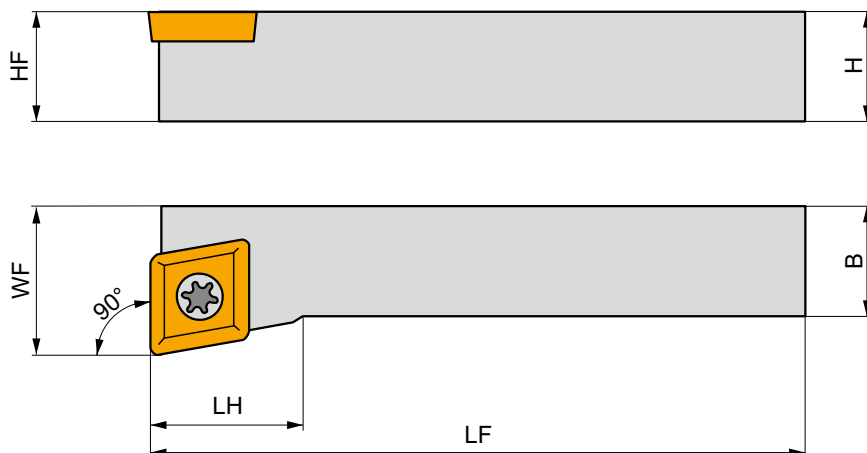
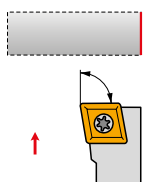

Product	H	B	HF	WF	LF	LH	LAMS	GAMO	kg	GI041	GI045	
	(mm)	(mm)	(mm)	(mm)	(mm)	(mm)	(°)	(°)				
R	SCFCR 0808 D 06	8	8	8	10	60	8	0	0	0.04	GI045	S07
	SCFCR 1010 E 06	10	10	10	12	70	8	0	0	0.07	GI045	S07
	SCFCR 1212 F 09	12	12	12	16	80	16	0	0	0.12	GI041	S04
	SCFCR 1616 H 09	16	16	16	20	100	16	0	0	0.22	GI041	S04
L	SCFCL 0808 D 06	8	8	8	10	60	8	0	0	0.04	GI045	S07
	SCFCL 1010 E 06	10	10	10	12	70	8	0	0	0.06	GI045	S07
	SCFCL 1212 F 09	12	12	12	16	80	16	0	0	0.10	GI041	S04
	SCFCL 1616 H 09	16	16	16	20	100	16	0	0	0.22	GI041	S04



GI041

CC.. 09T3..

GI045

CC.. 0602..



S04

US 3510-T15P

3.0

M 3.5

10.6

FLAG T15P

S07

US 2506-T07P

0.9

M 2.5

6.3

FLAG T07P



SCLC(RL) EXT



PRAMET

S

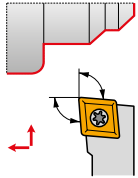

CC.. Uç için Vida Sıkmalı 95° Açılı Dış Kater

Vida sıkmalı Sağ/Sol 95° dış kater. Pozitif CC.. 06, 08, 09 veya 12 uçlarla çap, konik ve pah tornalama için uygundur. 08x08-25x25mm şaft ölçülerinde bulunur. Gövde uzun takım ömrü için işlem görmüştür.

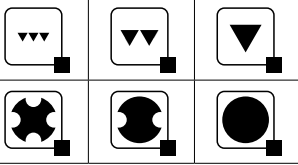
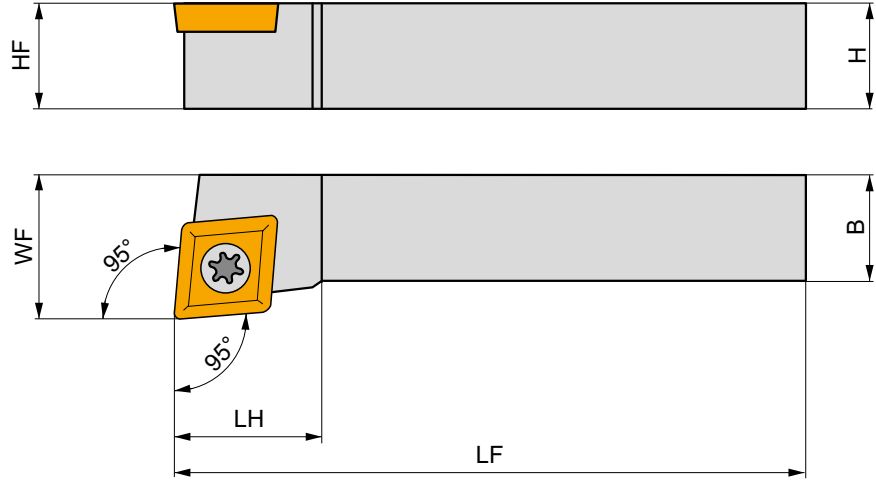

Product	H	B	HF	WF	LF	LH	LAMS	GAMO	kg	G1045	S01	
	(mm)	(mm)	(mm)	(mm)	(mm)	(mm)	(°)	(°)				
R	SCLCR 0808 D 06	8	8	8	10	60	8	0	0	0.06	G1045	S01
	SCLCR 1010 E 06	10	10	10	12	70	8	0	0	0.09	G1045	S01
	SCLCR 1010 E 08	10	10	10	12	70	13.2	0	0	0.03	G1232	SC22
	SCLCR 1212 F 08	12	12	12	16	80	13.4	0	0	0.02	G1232	SC22
	SCLCR 1616 H 08	16	16	16	20	100	15.2	0	0	0.22	G1232	SC22
	SCLCR 1212 F 09	12	12	12	16	80	16	0	0	0.12	G1041	S08
	SCLCR 1616 H 09	16	16	16	20	100	16	0	0	0.22	G1041	S08
	SCLCR 2020 K 12-M-A	20	20	20	25	125	20	0	0	0.44	G1011	SC20
	SCLCR 2525 M 12-M-A	20	25	20	32	150	20	0	0	0.68	G1011	SC20
L	SCLCL 0808 D 06	8	8	8	10	60	8	0	0	0.06	G1045	S01
	SCLCL 1010 E 06	10	10	10	12	70	8	0	0	0.06	G1045	S01
	SCLCL 1212 F 08	12	12	12	16	80	13.4	0	0	0.03	G1232	SC22
	SCLCL 1616 H 08	16	16	16	20	100	15.2	0	0	0.23	G1232	SC22
	SCLCL 1212 F 09	12	12	12	16	80	16	0	0	0.10	G1041	S08
	SCLCL 1616 H 09	16	16	16	20	100	16	0	0	0.22	G1041	S08
	SCLCL 2020 K 12-M-A	20	20	20	25	125	20	0	0	0.40	G1011	SC20
	SCLCL 2525 M 12-M-A	25	25	25	32	150	20	0	0	0.78	G1011	SC20



G1011
G1041
G1045
G1232

CC.. 1204..
CC.. 09T3..
CC.. 0602..
CC.. 0803..



SC20
SC22
S01
S08

US 5012-T15P
5513 020-04
US 2506-T07P
US 3510-T15P

5.0
1.5
0.9
3.0

M 5
M 3
M 2.5
M 3.5

12.2
7.2
6.3
10.6

SCN 120304
-
-
-

MS 5008
-
-
-

FLAG T15P
PT-8003
FLAG T07P
FLAG T15P

HXK 5
-
-
-

NEW
C.-SCLC(RL) EXT

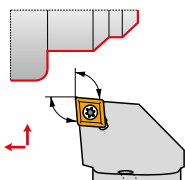
PRAMET
S

CC.. Uç için Vida Sıkmalı, 95° Açılı Hızlı Değişirme Dış Takımı

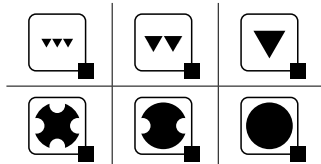
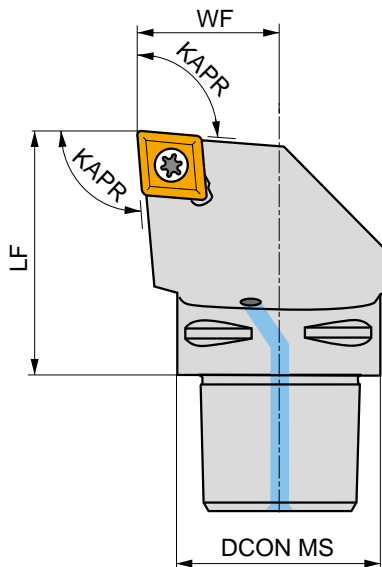
Vida sıkmalı Sağ/Sol, içten su vermeli 95° dış kater. Pozitif DC.. 07, 11 veya 15 uçlarla çap, kopya, konik, kopya ve pah tornalama için uygundur. PSC C3-C5 ölçülerinde bulunur. Gövde uzun takım ömrü için işlem görmüştür.



Product	DCON MS (mm)	WF (mm)	LF (mm)	KAPR (°)	LAMS (°)	GAMMO (°)		kg			
R	C3-SCLCR-22040-09	32	22	40	95	0	0	✓	0.21	GI041	C-SC09S
	C4-SCLCR-27050-09	40	27	50	95	0	0	✓	0.39	GI041	C-SC09S
	C4-SCLCR-27050-12	40	27	50	95	0	0	✓	0.40	GI011	C-SC12-1
L	C5-SCLCR-35060-12	50	35	60	95	0	0	✓	0.72	GI011	C-SC12-2
	C3-SCLCL-22040-09	32	22	40	95	0	0	✓	0.21	GI041	C-SC09S
	C4-SCLCL-27050-09	40	27	50	95	0	0	✓	0.39	GI041	C-SC09S
	C5-SCLCL-35060-12	50	35	60	95	0	0	✓	0.72	GI011	C-SC12-2



GI011

CC.. 1204..

GI041

CC.. 09T3..



C-SC09S	US 2001-T15P	3.0	M 3.5	12.1	SCS 232-01	MS 9001	FLAG T15P/3,5	CN 034-01
C-SC12-1	US 2018-T15P	3.0	M 4	14	SCS 232-02	MS 9003	FLAG T15P/4	CN 034-01
C-SC12-2	US 2018-T15P	3.0	M 4	14	SCS 232-02	MS 9003	FLAG T15P/4	CN 034-02



SCFC(RL) INT



PRAMET

S



CC.. Uç için Vida Sıkmalı 90° Açılı Delik Kateri

Vida sıkmalı Sağ/Sol 90° delik kateri. Pozitif CC.. 06 uçlarla minimum Ø13mm konik, çap ve pah tornalama için uygundur. Ø10-12mm şaft ölçülerinde bulunur. Gövde uzun takım ömrü için işlem görmüştür.

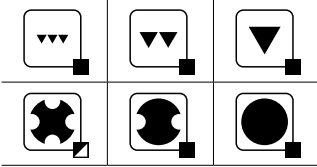
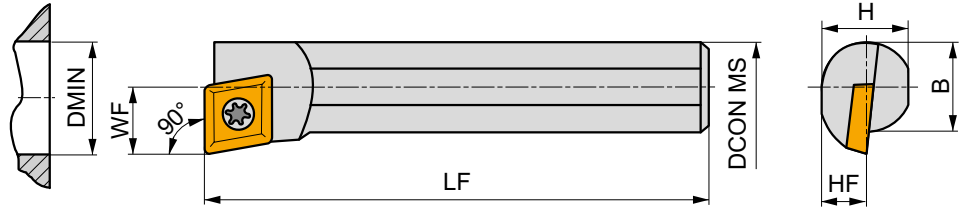
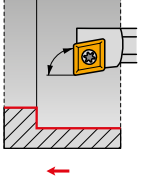

Product	DCON MS (mm)	DMIN (mm)	WF (mm)	H (mm)	B (mm)	LF (mm)	LAMS (°)	GAMO (°)	kg	GI045	S06
R S10H-SCFCR 06	10	13	7	9	9.5	100	-10	0	0.08	GI045	S06
S12K-SCFCR 06	12	16	9	11	11.5	125	-7	0	0.11	GI045	S06
L S10H-SCFCL 06	10	13	7	9	9.5	100	-10	0	0.10	GI045	S06
S12K-SCFCL 06	12	16	9	11	11.5	125	-7	0	0.14	GI045	S06



GI045



CC..0602..



S06



US 2505-T07P



0.9



M 2.5



5.2



FLAG T07P



SCKC(RL) INT



PRAMET

S



CC.. Uç için Vida Sıkmalı 75° Açılı Delik Kateri

Vida sıkmalı Sağ/Sol 75° delik kateri. Pozitif CC.. 06, 09 ve 12 uçlarla minimum Ø11mm konik, çap ve pah tormalama için uygundur. Ø8-32mm şaft ölçülerinde bulunur. Gövde uzun takım ömrü için işlem görmüştür.

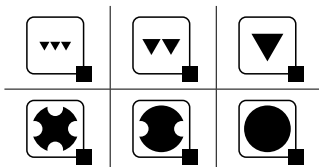
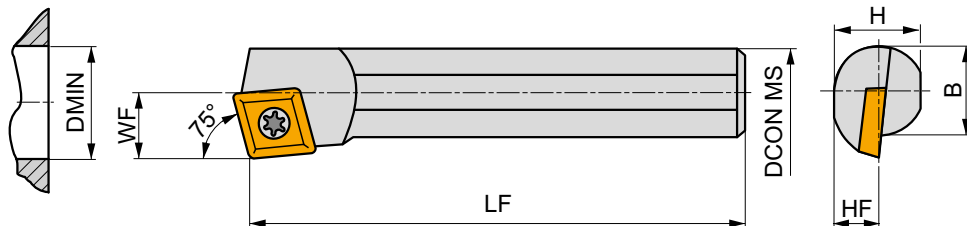
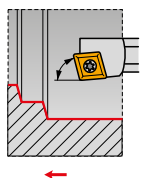

Product	DCON MS (mm)	DMIN (mm)	WF (mm)	H (mm)	B (mm)	LF (mm)	LAMS (°)	GAMO (°)	kg	GI045	S02	
R	S08F-SCKCR 06	8	11	6	7.2	7.6	80	-12	0	0.03	GI045	S02
	S12K-SCKCR 06	12	16	9	11	11.5	125	-8	0	0.11	GI045	S02
	S16M-SCKCR 09-A	16	20	11	14.5	15	150	-8	0	0.25	GI041	S05
	S20S-SCKCR 09	20	25	13	18.5	18.5	250	-5	0	0.60	GI041	S08
	S25T-SCKCR 09	25	32	17	23	23	300	-3	0	1.15	GI041	S08
	S32U-SCKCR 12-A	32	40	22	30	30	350	-10	0	2.10	GI011	SC20
L	S08F-SCKCL 06	8	11	6	7.2	7.6	80	-12	0	0.03	GI045	S02
	S12K-SCKCL 06	12	16	9	11	11.5	125	-8	0	0.11	GI045	S02
	S16M-SCKCL 09-A	16	20	11	14.5	15	150	-8	0	0.24	GI041	S05
	S20S-SCKCL 09	20	25	13	18.5	18.5	250	-5	0	0.60	GI041	S08
	S25T-SCKCL 09	25	32	17	23	23	300	-3	0	1.15	GI041	S08
	S32U-SCKCL 12-A	32	40	22	30	30	350	-10	0	2.10	GI011	SC20



GI011

CC.. 1204..

GI041

CC.. 09T3..

GI045

CC.. 0602..



SC20

US 5012-T15P

5.0

M 5

12.2

SCN 120304

MS 5008

FLAGT15P

HXK 5

S02

US 2505-T07P

0.9

M 2.5

5.2

-

-

FLAGT07P

-

S05

US 4008-T15P

3.5

M 4

8

-

-

FLAGT15P

-

S08

US 3510-T15P

3.0

M 3.5

10.6

-

-

FLAGT15P

-



SCLC(RL) INT



PRAMET

S



CC.. Uç için Vida Sıkmalı 95° Açılı Delik Kateri

Vida sıkmalı Sağ/Sol 95° içten su vermeli delik kateri. Pozitif CC.. 06, 08, 09 ve 12 uçlarla minimum Ø11mm çap, konik ve pah tornalama için uygundur. Ø8-32mm şaft ölçülerinde bulunur. Gövde uzun takım ömrü için işlem görmüştür.

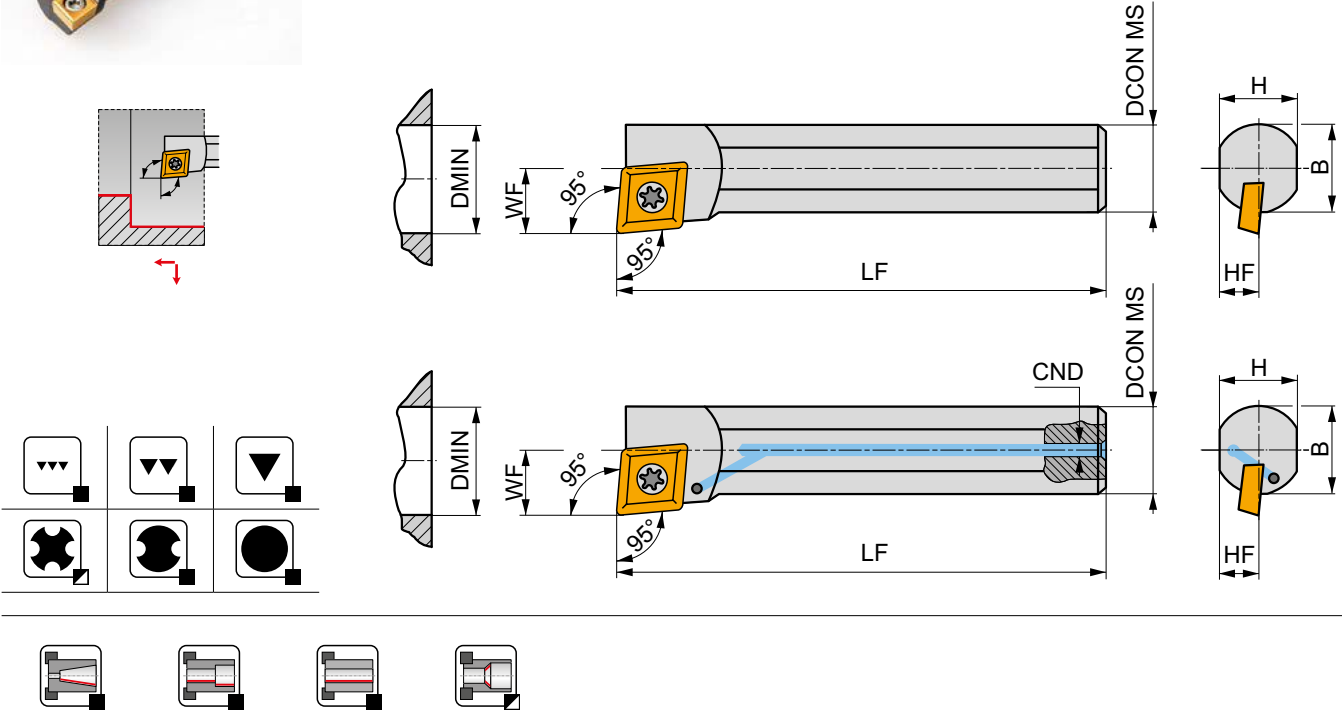

Product	DCON MS	DMIN	WF	H	B	LF	CND	LAMS	GAMO	✓	kg	GI045	S02
	(mm)	(mm)	(mm)	(mm)	(mm)	(mm)	(°)	(°)					
R A08H-SCLCR 06	8	11	6	7.2	7.6	100	3.5	-13	0	✓	0.06	GI045	S02
S08F-SCLCR 06	8	11	6	7.2	7.6	80	-	-13	0	-	0.06	GI045	S02
A10H-SCLCR 06	10	13	7	9	-	100	4	-10	0	✓	0.07	GI045	S02
S10H-SCLCR 06	10	13	7	9	9.5	100	-	-10	0	-	0.08	GI045	S02
A12K-SCLCR 06	12	16	9	11	-	125	5	-8	0	✓	0.11	GI045	S01
S12K-SCLCR 06	12	16	9	11	11.5	125	-	-8	0	-	0.13	GI045	S01
S16M-SCLCR 06	16	20	11	14.5	15	150	-	-8	0	-	0.25	GI045	S01
A10K-SCLCR 08	10	12	6	9	9.5	125	4	-14	0	✓	0.09	GI232	SC22
A12M-SCLCR 08	12	16	9	11	11.5	150	5	-5	0	✓	0.14	GI232	SC22
A16R-SCLCR 08	16	20	11	14	15	200	6	-8	0	✓	0.28	GI232	SC22
A16M-SCLCR 09-A	16	20	11	14.5	-	150	6	-8	0	✓	0.22	GI041	S05
S16M-SCLCR 09-A	16	20	11	14.5	15	150	-	-8	0	-	0.25	GI041	S05
A20Q-SCLCR 09	20	25	13	18	-	180	8	-5	0	✓	0.38	GI041	S08
S20S-SCLCR 09	20	25	13	18	18.5	250	-	-5	0	-	0.62	GI041	S08
A25R-SCLCR 09	25	32	17	23	23	200	8	-3	0	✓	0.60	GI041	S08
S25T-SCLCR 09	25	32	17	23	23	300	-	-3	0	-	1.10	GI041	S08
A32S-SCLCR 12-A	32	40	22	30	30	250	8	-10	0	✓	1.35	GI011	SC20
S32U-SCLCR 12-A	32	40	22	30	30	350	-	-10	0	-	2.10	GI011	SC20
L A08H-SCLCL 06	8	11	6	7.2	7.6	100	-	-13	0	✓	0.06	GI045	S02
S08F-SCLCL 06	8	11	6	7.2	7.6	80	-	-13	0	-	0.05	GI045	S02
A10H-SCLCL 06	10	13	7	9	-	100	4	-10	0	✓	0.06	GI045	S02
S10H-SCLCL 06	10	13	7	9	9.5	100	-	-10	0	-	0.06	GI045	S02
A12K-SCLCL 06	12	16	9	11	-	125	5	-8	0	✓	0.10	GI045	S01
S12K-SCLCL 06	12	16	9	11	11.5	125	-	-8	0	-	0.11	GI045	S01
S16M-SCLCL 06	16	20	11	14.5	15	150	-	-8	0	-	0.26	GI045	S01
A10K-SCLCL 08	10	12	6	9	9.5	125	4	-14	0	✓	0.02	GI232	SC22
A12M-SCLCL 08	12	16	9	11	11.5	150	5	-5	0	✓	0.14	GI232	SC22



Product	DCON MS	DMIN	WF	H	B	LF	CND	LAMS	GAMO				
	(mm)	(mm)	(mm)	(mm)	(mm)	(mm)	(mm)	(°)	(°)				
A16R-SCLCL 08	16	20	11	14	15	200	6	-8	0	✓	0.30	GI232	SC22
A16M-SCLCL 09-A	16	20	11	14.5	–	150	6	-8	0	✓	0.22	GI041	S05
S16M-SCLCL 09-A	16	20	11	14.5	15	150	–	-8	0	–	0.24	GI041	S05
A20Q-SCLCL 09	20	25	13	18	–	180	8	-5	0	✓	0.40	GI041	S08
S20S-SCLCL 09	20	25	13	18	18.5	250	–	-5	0	–	0.60	GI041	S08
A25R-SCLCL 09	25	32	17	23	23	200	8	-3	0	✓	0.67	GI041	S08
S25T-SCLCL 09	25	32	17	23	23	300	–	-3	0	–	1.15	GI041	S08
A32S-SCLCL 12-A	32	40	22	30	30	250	8	-10	0	✓	1.35	GI011	SC20
S32U-SCLCL 12-A	32	40	22	30	30	350	–	-10	0	–	2.10	GI011	SC20

L



GI011	CC.. 1204..
GI041	CC.. 09T3..
GI045	CC.. 0602..
GI232	CC.. 0803..



SC20	US 5012-T15P	5.0	M 5	12.2	SCN 120304	MS 5008	FLAG T15P	HXK 5
SC22	5513 020-04	1.5	M 3	7.2	–	–	PT-8003	–
S01	US 2506-T07P	0.9	M 2.5	6.3	–	–	FLAG T07P	–
S02	US 2505-T07P	0.9	M 2.5	5.2	–	–	FLAG T07P	–
S05	US 4008-T15P	3.5	M 4	8	–	–	FLAG T15P	–
S08	US 3510-T15P	3.0	M 3.5	10.6	–	–	FLAG T15P	–



SCXC(RL) INT



PRAMET

S



CC.. Uç için Vida Sıkmalı 40° Açılı Delik Kateri

Vida sıkmalı Sağ/Sol 40° delik kateri. Pozitif CC.. 06 uçlarla minimum Ø13mm çap, konik, ve ters pah tornalama için uygundur. Ø10-16mm shaft ölçülerinde bulunur. Gövde uzun takım ömrü için işlem görmüştür.

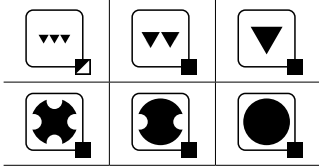
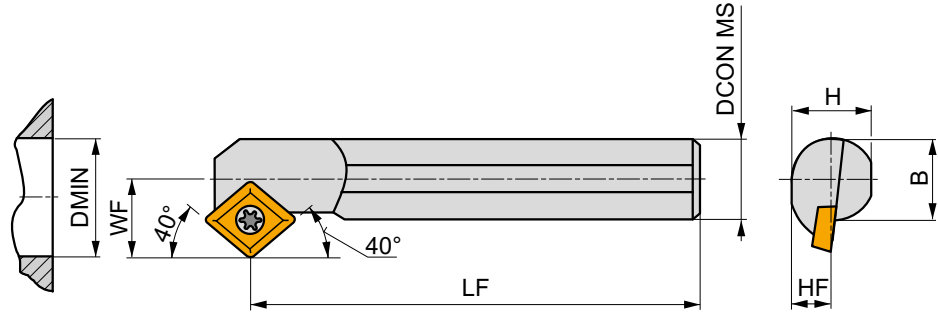
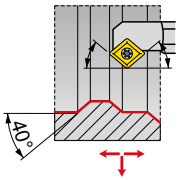

Product	DCON MS	DMIN	WF	H	B	LF	LAMS	GAMO	kg	G1045	S06
	(mm)	(mm)	(mm)	(mm)	(mm)	(mm)	(°)	(°)			
R S10H-SCXCR 06	10	13	7	9	9.5	100	-10	0	0.06	G1045	S06
S12K-SCXCR 06	12	16	9	11	11.5	125	-8	0	0.11	G1045	S06
S16Q-SCXCR 06	16	20	11	14.5	15	180	-7	0	0.31	G1045	S07
L S10H-SCXCL 06	10	13	7	9	9.5	100	-10	0	0.06	G1045	S06
S12K-SCXCL 06	12	16	9	11	11.5	125	-8	0	0.11	G1045	S06
S16Q-SCXCL 06	16	20	11	14.5	15	180	-7	0	0.30	G1045	S07



G1045



CC.. 0602..



S06



US 2505-T07P



Nm

0.9



M 2.5



5.2



FLAGT07P

S07

US 2506-T07P

0.9

M 2.5

6.3

FLAGT07P

NEW
C.-SCLC(RL) INT

PRAMET
S

CC.. Uç için Vida Sıkmalı 95° Açılı PSC Hızlı Değişirme Delik Takımı

Vida sıkmalı Sağ/Sol 95° içten su vermeli delik kateri. Pozitif CC.. 09 uçlarla minimum Ø20mm çap, ve birçok çeşit tornalama için uygundur. C3-5 şaft ve çeşitli boy ölçülerinde bulunur. Gövde uzun takım ömrü için işlem görmüştür.

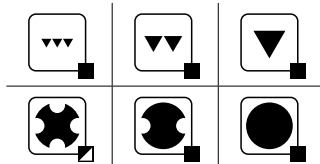
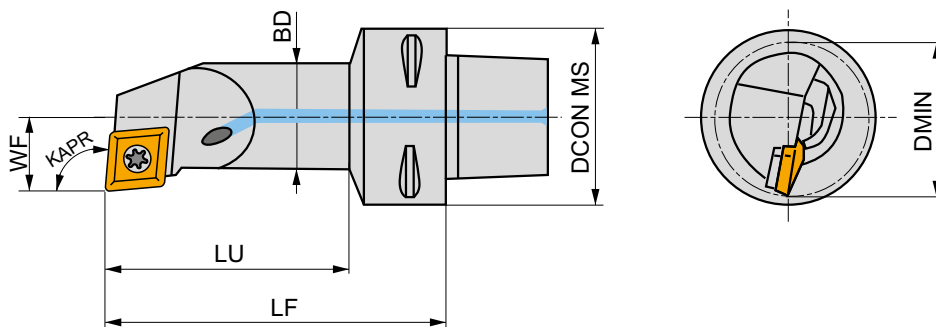
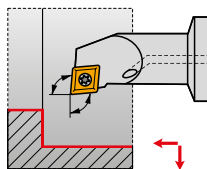

Product	DCON MS	DMIN	WF	LF	LU	BD	KAPR	LAMS	GAMO	✓	kg	GI041	SC09M	
	(mm)	(mm)	(mm)	(mm)	(mm)	(mm)	(°)	(°)	(°)					
R	C3-SCLCR-11065-09	32	20	11	65	48	16	95	-8.4	0	✓	0.21	GI041	SC09M
	C3-SCLCR-13075-09	32	25	13	75	58	20	95	-5.8	0	✓	0.26	GI041	SC09M
	C4-SCLCR-11070-09	40	20	11	70	47	16	95	-8.4	0	✓	0.36	GI041	SC09M
	C4-SCLCR-13080-09	40	25	13	80	57	20	95	-5.8	0	✓	0.41	GI041	SC09M
	C4-SCLCR-17090-09	40	32	17	90	68	25	95	-3.4	0	✓	0.50	GI041	SC09M
	C5-SCLCR-11070-09	50	20	11	70	46	16	95	-8.4	0	✓	0.55	GI041	SC09M
L	C5-SCLCR-13080-09	50	25	13	80	56	20	95	-5.8	0	✓	0.60	GI041	SC09M
	C4-SCLCL-11070-09	40	20	11	70	47	16	95	-8.4	0	✓	0.36	GI041	SC09M
	C4-SCLCL-13080-09	40	25	13	80	57	20	95	-5.8	0	✓	0.62	GI041	SC09M
	C5-SCLCL-11070-09	50	20	11	70	46	16	95	-8.4	0	✓	0.55	GI041	SC09M
	C5-SCLCL-13080-09	50	25	13	80	56	20	95	-5.8	0	✓	0.60	GI041	SC09M



GI041



CC.. 09T3..



SC09M



US 2009-T15P



3.0



M 3.5



8.1



FLAGT15P/3,5



CP

05

KARBÜR UÇLAR

CPGX

 83







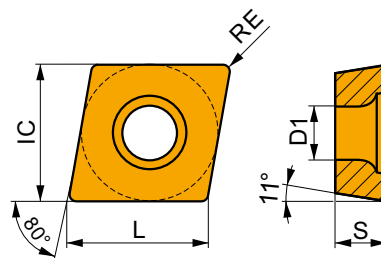



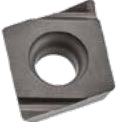
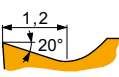

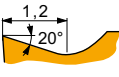

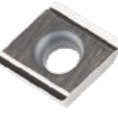
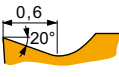
CPGX

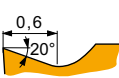
	IC	D1	L	S
	(mm)	(mm)	(mm)	(mm)
0602	6.350	2.80	6.40	2.38
0803	7.940	3.40	8.10	3.18
09T3	9.525	4.40	9.70	3.97

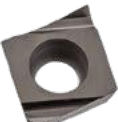
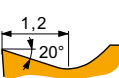

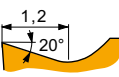
Kesme hızı (vc), ilerleme (f) ve kesme derinliği (ap) için uygunluk ve başlangıç değerleri. Daha ileri hesaplamalar için İşleme Hesaplayıcısı uygulamasına başvurun.

Product	RE	P			M			K			N			S			H			
		vc	f	ap	vc	f	ap	vc	f	ap	vc	f	ap	vc	f	ap	vc	f	ap	
	(mm)	(m/min)	(mm/rev)	(mm)	(m/min)	(mm/rev)	(mm)	(m/min)	(mm/rev)	(mm)	(m/min)	(mm/rev)	(mm)	(m/min)	(mm/rev)	(mm)	(m/min)	(mm/rev)	(mm)	
			FR-JQ sağ kesme yönlü geometri, ince finiş işleme için çok pozitif tasarım, darbesiz kesime uygun.																	
CPGX 080304FR-JQ	TT010 0.4	350	0.06	0.5	210	0.05	0.5	-	-	-	-	-	-	-	-	-	-	-	-	
			FL-JQ sol kesme yönlü geometri, ince finiş işleme için çok pozitif tasarım, darbesiz kesime uygun.																	
CPGX 080304FL-JQ	TT010 0.4	350	0.06	0.5	210	0.05	0.5	-	-	-	-	-	-	-	-	-	-	-	-	
CPGX 09T304FL-JQ	TT010 0.4	350	0.06	0.5	210	0.05	0.5	-	-	-	-	-	-	-	-	-	-	-	-	
			FR-JR sağ kesme yönlü geometri, ince finiş işleme için çok pozitif tasarım, darbesiz kesime uygun.																	
CPGX 060204FR-JR	TT010 0.4	350	0.06	0.5	210	0.05	0.5	-	-	-	-	-	-	-	-	-	-	-	-	
CPGX 080304FR-JR	TT010 0.4	350	0.06	0.5	210	0.05	0.5	-	-	-	-	-	-	-	-	-	-	-	-	
			FL-JR sol kesme yönlü geometri, ince finiş işleme için çok pozitif tasarım, darbesiz kesime uygun.																	
CPGX 060204FL-JR	TT010 0.4	350	0.06	0.5	210	0.05	0.5	-	-	-	-	-	-	-	-	-	-	-	-	
CPGX 080304FL-JR	TT010 0.4	350	0.06	0.5	210	0.05	0.5	-	-	-	-	-	-	-	-	-	-	-	-	
			FR-JR sağ kesme yönlü geometri, ince finiş işleme için çok pozitif tasarım, darbesiz kesime uygun.																	
CPGX 060202FR-JZ	TT010 0.2	330	0.06	0.5	195	0.05	0.5	-	-	-	-	-	-	-	-	-	-	-	-	
			FL-JR sol kesme yönlü geometri, ince finiş işleme için çok pozitif tasarım, darbesiz kesime uygun.																	
CPGX 060202FL-JZ	TT010 0.2	330	0.06	0.5	195	0.05	0.5	-	-	-	-	-	-	-	-	-	-	-	-	



DC

07 / 11 / 15

KARBÜR UÇLAR

DCGT	DCMT	DCMW
86	87	92

CBN & PCD UÇLAR

DCGW CBN	DCMW PCD
92	93

DOĞRU BOYUTLA EŞLEŞTİRİN (örnek)

Kesici uç	Takım Tutucu
DCMT 070204E-UR	SDJCR 0808 D 07

ISO TORNALAMA - DIŞ

SDJC(RL) EXT		SDNCN EXT		C.-SDNCN EXT NEW		C.-SDJC(RL) EXT NEW	
93°	DC..	62°30'	DC..	62°30'	DC..	93°	DC..
07 11 15		7 11		11		11	
08×08 25×25		08×08 25×25		C4 C5		C3 C5	
94	86-93	95	86-93	97	86-93	96	86-93



DC

07 / 11 / 15

ISO TORNALAMA - İÇ

SDQC(RL) INT

107°30'

DC..

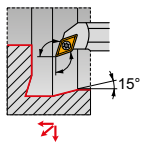
07
1113
40

98

86-93

SDUC(RL) INT

93°

DC..

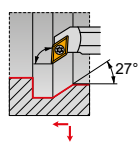
07
1113
40

99

86-93

SDUC(RL)-E INT

93°

DC..

07
1113
40

100

86-93

SDZC(RL) INT

93°

DC..

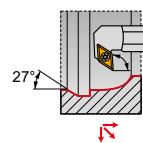
07
1127
65

101

86-93

C-SDUC(RL) INT **NEW**

93°

DC..

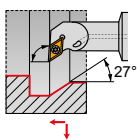
07
1120
32

102

86-93



DCGT



	IC	D1	L	S
	(mm)	(mm)	(mm)	(mm)
0702	6.350	2.80	7.80	2.38
0702-SF3	6.350	2.80	7.80	2.58
11T3	9.525	4.40	11.60	3.97
11T3-SF3	9.525	4.40	11.60	4.22

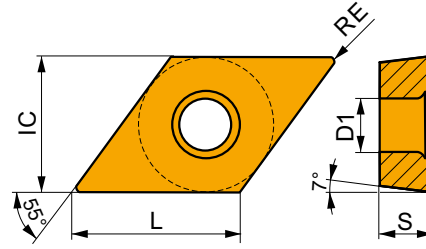

Kesme hızı (vc), ilerleme (f) ve kesme derinliği (ap) için uygunluk ve başlangıç değerleri. Daha ileri hesaplamalar için İşleme Hesaplayıcısı uygulamasına başvurun.

Product	RE	P			M			K			N			S			H		
		vc	f	ap	vc	f	ap	vc	f	ap	vc	f	ap	vc	f	ap	vc	f	ap
	(mm)	(m/min)	(mm/rev)	(mm)	(m/min)	(mm/rev)	(mm)	(m/min)	(mm/rev)	(mm)	(m/min)	(mm/rev)	(mm)	(m/min)	(mm/rev)	(mm)	(m/min)	(mm/rev)	(mm)



AL geometri, ince finişten kabaya, ve darbesizden hafif darbeli kesmeye kadar uygun, çok pozitif tasarım.

DCGT 070202F-AL	HF7	0.2	-	-	-	-	-	-	-	360	0.12	1.0	-	-	-	-	-	-
	T0315	0.2	-	-	-	-	-	-	-	510	0.12	1.0	-	-	-	-	-	-
DCGT 070204F-AL	HF7	0.4	-	-	-	-	-	-	-	285	0.24	1.0	-	-	-	-	-	-
	T0315	0.4	-	-	-	-	-	-	-	420	0.24	1.0	-	-	-	-	-	-
DCGT 11T302F-AL	HF7	0.2	-	-	-	-	-	-	-	345	0.12	1.5	-	-	-	-	-	-
	T0315	0.2	-	-	-	-	-	-	-	495	0.12	1.5	-	-	-	-	-	-
DCGT 11T304F-AL	HF7	0.4	-	-	-	-	-	-	-	270	0.24	1.5	-	-	-	-	-	-
	T0315	0.4	-	-	-	-	-	-	-	390	0.24	1.5	-	-	-	-	-	-
DCGT 11T308F-AL	HF7	0.8	-	-	-	-	-	-	-	255	0.48	1.5	-	-	-	-	-	-
	T0315	0.8	-	-	-	-	-	-	-	360	0.48	1.5	-	-	-	-	-	-

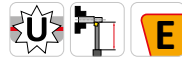
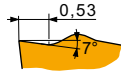

FF2 geometri, ince-finişten finiş işleme kadar için çok pozitif tasarım, darbesizden hafif darbeli işleme kadar uygun.

DCGT 11T302E-FF2	T7325	0.2	190	0.05	0.8	-	-	-	-	-	-	-	-	-	-	-	-	-
	T8330	0.2	165	0.05	0.8	-	-	-	155	0.05	0.8	-	-	-	-	-	-	-
	T8430	0.2	225	0.05	0.8	-	-	-	185	0.05	0.8	-	-	-	-	-	-	-
	T9325	0.2	280	0.05	0.8	-	-	-	265	0.05	0.8	-	-	-	-	-	-	-
	TT010	0.2	275	0.05	0.5	-	-	-	-	-	-	-	-	-	-	-	-	-

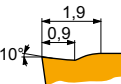

NF1 geometri, ince finişten ortaya kadar işlemek için pozitif tasarım, darbesiz kesim için uygun.

DCGT 11T304E-NF1	T6310	0.4	145	0.10	0.8	100	0.09	0.8	-	-	-	435	0.12	0.8	40	0.07	0.6	25	0.15	1.0
	T7325	0.4	165	0.10	0.8	125	0.09	0.8	-	-	-	-	-	-	50	0.07	0.6	-	-	-
DCGT 11T308E-NF1	T6310	0.8	155	0.14	0.8	110	0.13	0.8	-	-	-	465	0.17	0.8	45	0.13	0.6	30	0.15	1.0
	T7325	0.8	180	0.14	0.8	140	0.13	0.8	-	-	-	-	-	-	55	0.13	0.6	-	-	-

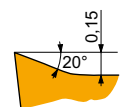

SF3 geometri, inceden finiş işleme kadar işlemek için çok pozitif tasarım, darbesiz kesim için uygun.

DCGT 070201E-SF3	T6310	0.1	160	0.05	0.5	115	0.05	0.5	125	0.05	0.5	480	0.06	0.5	45	0.04	0.4	30	0.15	1.0
DCGT 070202E-SF3	H07	0.2	-	-	-	95	0.05	0.8	150	0.05	0.8	485	0.06	0.8	45	0.04	0.6	-	-	-
	T6310	0.2	165	0.05	0.8	115	0.05	0.8	130	0.05	0.8	495	0.06	0.8	45	0.04	0.6	30	0.15	1.0
	T8315	0.2	175	0.05	0.8	105	0.05	0.8	165	0.05	0.8	525	0.06	0.8	40	0.04	0.6	35	0.15	1.0
DCGT 070204E-SF3	H07	0.4	-	-	-	75	0.09	0.8	120	0.10	0.8	390	0.12	0.8	35	0.07	0.6	-	-	-
	T6310	0.4	145	0.10	0.8	100	0.09	0.8	115	0.10	0.8	435	0.12	0.8	40	0.07	0.6	25	0.15	1.0
	T8315	0.4	155	0.10	0.8	90	0.09	0.8	145	0.10	0.8	465	0.12	0.8	35	0.07	0.6	30	0.15	1.0
DCGT 11T301E-SF3	T6310	0.1	160	0.05	0.5	115	0.05	0.5	125	0.05	0.5	480	0.06	0.5	45	0.04	0.4	30	0.15	1.0



Kesme hızı (vc), ilerleme (f) ve kesme derinliği (ap) için uygunluk ve başlangıç değerleri. Daha ileri hesaplamalar için İşleme Hesaplayıcısı uygulamasına başvurun.

Product	RE (mm)	P			M			K			N			S			H		
		vc (m/min)	f (mm/rev)	ap (mm)	vc (m/min)	f (mm/rev)	ap (mm)	vc (m/min)	f (mm/rev)	ap (mm)	vc (m/min)	f (mm/rev)	ap (mm)	vc (m/min)	f (mm/rev)	ap (mm)	vc (m/min)	f (mm/rev)	ap (mm)

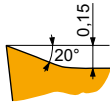

SF3 geometri, inceden finiş işlemeye kadar işlemek için çok pozitif tasarım, darbesiz kesim için uygun.

DCGT 11T302E-SF3	H07	0.2	-	-	-	95	0.05	0.8	150	0.05	0.8	485	0.06	0.8	45	0.04	0.6	-	-	-
	T6310	0.2	165	0.05	0.8	115	0.05	0.8	130	0.05	0.8	495	0.06	0.8	45	0.04	0.6	30	0.15	1.0
DCGT 11T304E-SF3	H07	0.4	-	-	-	75	0.09	0.8	120	0.10	0.8	390	0.12	0.8	35	0.07	0.6	-	-	-
	T6310	0.4	145	0.10	0.8	100	0.09	0.8	115	0.10	0.8	435	0.12	0.8	40	0.07	0.6	25	0.15	1.0
	T8315	0.4	155	0.10	0.8	90	0.09	0.8	145	0.10	0.8	465	0.12	0.8	35	0.07	0.6	30	0.15	1.0
DCGT 11T308E-SF3	H07	0.8	-	-	-	90	0.09	0.8	145	0.10	0.8	455	0.12	0.8	45	0.08	0.6	-	-	-
	T6310	0.8	170	0.10	0.8	120	0.09	0.8	135	0.10	0.8	510	0.12	0.8	50	0.08	0.6	30	0.15	1.0
	T8315	0.8	180	0.10	0.8	105	0.09	0.8	170	0.10	0.8	540	0.12	0.8	45	0.08	0.6	35	0.15	1.0

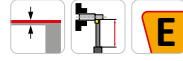

ER-SI geometri, çok pozitif sağ kesme yönlü tasarım, ince finişten yarı kaba işlemeye kadar, ve darbesiz kesim için uygun.

DCGT 11T304ER-SI	T8330	0.4	170	0.12	0.8	100	0.11	0.8	160	0.12	0.8	-	-	-	40	0.10	0.6	-	-	-
	T8430	0.4	205	0.12	0.8	110	0.11	0.8	170	0.12	0.8	-	-	-	45	0.10	0.6	-	-	-
DCGT 11T308ER-SI	T8330	0.8	170	0.22	1.0	100	0.20	1.0	160	0.22	1.0	-	-	-	40	0.18	0.8	-	-	-
	T8430	0.8	190	0.22	1.0	105	0.20	1.0	155	0.22	1.0	-	-	-	40	0.18	0.8	-	-	-

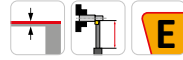

EL-SI geometri, çok pozitif sol kesme yönlü tasarım, ince finişten yarı kaba işlemeye kadar, ve darbesiz kesim için uygun.

DCGT 11T304EL-SI	T8330	0.4	170	0.12	0.8	100	0.11	0.8	160	0.12	0.8	-	-	-	40	0.10	0.6	-	-	-
	T8430	0.4	205	0.12	0.8	110	0.11	0.8	170	0.12	0.8	-	-	-	45	0.10	0.6	-	-	-
DCGT 11T308EL-SI	T8430	0.8	190	0.22	1.0	105	0.20	1.0	155	0.22	1.0	-	-	-	40	0.18	0.8	-	-	-

DCMT



	IC (mm)	D1 (mm)	L (mm)	S (mm)
0702	6.350	2.80	7.80	2.38
11T3	9.525	4.40	11.60	3.97
1504	12.700	5.50	15.50	4.76

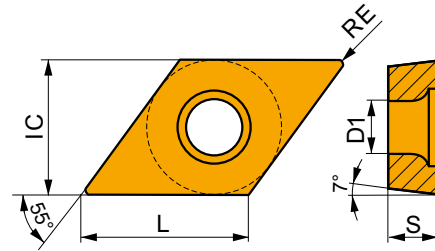

Kesme hızı (vc), ilerleme (f) ve kesme derinliği (ap) için uygunluk ve başlangıç değerleri. Daha ileri hesaplamalar için İşleme Hesaplayıcısı uygulamasına başvurun.

Product	RE (mm)	P			M			K			N			S			H		
		vc (m/min)	f (mm/rev)	ap (mm)	vc (m/min)	f (mm/rev)	ap (mm)	vc (m/min)	f (mm/rev)	ap (mm)	vc (m/min)	f (mm/rev)	ap (mm)	vc (m/min)	f (mm/rev)	ap (mm)	vc (m/min)	f (mm/rev)	ap (mm)

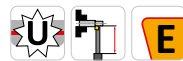
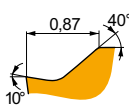

FF geometri, ince-finiş işleme için çok pozitif tasarım, darbesizden hafif darbeli işlemeye kadar uygun.

DCMT 11T302E-FF	T8315	0.2	160	0.10	0.8	95	0.09	0.8	-	-	-	-	-	-	-	-	-	-	-	-
	T8330	0.2	150	0.10	0.8	90	0.09	0.8	-	-	-	-	-	-	-	-	-	-	-	-
	T8430	0.2	185	0.10	0.8	100	0.09	0.8	-	-	-	-	-	-	-	-	-	-	-	-
	T9315	0.2	255	0.10	0.8	-	-	-	-	-	-	-	-	-	-	-	-	-	-	-



Kesme hızı (vc), ilerleme (f) ve kesme derinliği (ap) için uygunluk ve başlangıç değerleri. Daha ileri hesaplamalar için İşleme Hesaplayıcısı uygulamasına başvurun.

Product	RE (mm)	P			M			K			N			S			H		
		vc (m/min)	f (mm/rev)	ap (mm)	vc (m/min)	f (mm/rev)	ap (mm)	vc (m/min)	f (mm/rev)	ap (mm)	vc (m/min)	f (mm/rev)	ap (mm)	vc (m/min)	f (mm/rev)	ap (mm)	vc (m/min)	f (mm/rev)	ap (mm)

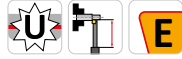
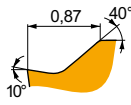

FF geometri, ince-finiş işleme için çok pozitif tasarım, darbesizden hafif darbeleri işlemeye kadar uygun.

DCMT 11T304E-FF	T8315	0.4	✓	160	0.12	0.8	✓	95	0.11	0.8	-	-	-	-	-	-	-	-	-
	T8330	0.4	■	150	0.12	0.8	✓	90	0.11	0.8	-	-	-	-	-	-	-	-	-
	T8430	0.4	■	185	0.12	0.8	✓	100	0.11	0.8	-	-	-	-	-	-	-	-	-
	T9315	0.4	■	255	0.12	0.8	-	-	-	-	-	-	-	-	-	-	-	-	-
DCMT 11T308E-FF	T8315	0.8	✓	180	0.15	0.8	✓	105	0.14	0.8	-	-	-	-	-	-	-	-	-
	T8330	0.8	■	170	0.15	0.8	✓	100	0.14	0.8	-	-	-	-	-	-	-	-	-
	T8430	0.8	■	200	0.15	0.8	✓	110	0.14	0.8	-	-	-	-	-	-	-	-	-
	T9315	0.8	■	270	0.15	0.8	-	-	-	-	-	-	-	-	-	-	-	-	-

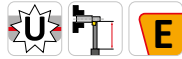
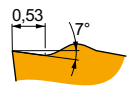

FF2 geometri, ince-finiştan finişe işlemeye kadar için çok pozitif tasarım, darbesizden hafif darbeleri işlemeye kadar uygun.

DCMT 070202E-FF2	T7325	0.2	✓	190	0.05	0.8	-	-	-	-	-	-	-	-	-	-	-	-
	T8330	0.2	■	165	0.05	0.8	-	-	-	■	155	0.05	0.8	-	-	-	-	-
	T8430	0.2	■	225	0.05	0.8	-	-	-	✓	185	0.05	0.8	-	-	-	-	-
	T9325	0.2	■	280	0.05	0.8	-	-	-	✓	265	0.05	0.8	-	-	-	-	-
	TT010	0.2	■	275	0.05	0.5	-	-	-	-	-	-	-	-	-	-	-	-
DCMT 070204E-FF2	T7325	0.4	✓	160	0.12	0.8	-	-	-	-	-	-	-	-	-	-	-	-
	T8330	0.4	■	135	0.12	0.8	-	-	-	■	125	0.12	0.8	-	-	-	-	-
	T8430	0.4	■	170	0.12	0.8	-	-	-	✓	135	0.12	0.8	-	-	-	-	-
	T9315	0.4	■	230	0.12	0.8	-	-	-	✓	215	0.12	0.8	-	-	-	-	-
	T9325	0.4	■	205	0.12	0.8	-	-	-	✓	190	0.12	0.8	-	-	-	-	-
DCMT 070208E-FF2	T7325	0.8	✓	170	0.17	0.8	-	-	-	-	-	-	-	-	-	-	-	-
	T8330	0.8	■	150	0.17	0.8	-	-	-	■	140	0.17	0.8	-	-	-	-	-
	T8430	0.8	■	175	0.17	0.8	-	-	-	✓	140	0.17	0.8	-	-	-	-	-
	T9315	0.8	■	235	0.17	0.8	-	-	-	✓	220	0.17	0.8	-	-	-	-	-
	T9325	0.8	■	215	0.17	0.8	-	-	-	✓	200	0.17	0.8	-	-	-	-	-
DCMT 11T304E-FF2	T7325	0.4	✓	160	0.12	0.8	-	-	-	-	-	-	-	-	-	-	-	-
	T8330	0.4	■	135	0.12	0.8	-	-	-	■	125	0.12	0.8	-	-	-	-	-
	T8430	0.4	■	170	0.12	0.8	-	-	-	✓	135	0.12	0.8	-	-	-	-	-
	T9315	0.4	■	230	0.12	0.8	-	-	-	✓	215	0.12	0.8	-	-	-	-	-
	T9325	0.4	■	205	0.12	0.8	-	-	-	✓	190	0.12	0.8	-	-	-	-	-
	T9335	0.4	■	175	0.12	0.8	-	-	-	-	-	-	-	-	-	-	-	-
DCMT 11T308E-FF2	TT010	0.4	■	280	0.06	0.5	-	-	-	-	-	-	-	-	-	-	-	-
	T7325	0.8	✓	170	0.17	0.8	-	-	-	-	-	-	-	-	-	-	-	-
	T8330	0.8	■	150	0.17	0.8	-	-	-	■	140	0.17	0.8	-	-	-	-	-
	T8430	0.8	■	175	0.17	0.8	-	-	-	✓	140	0.17	0.8	-	-	-	-	-
	T9315	0.8	■	235	0.17	0.8	-	-	-	✓	220	0.17	0.8	-	-	-	-	-

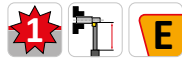

FM geometri, finişten yarı kaba işlemeye, ve darbesizden hafif darbeleri kesmeye kadar uygun.

DCMT 070202E-FM	T7325	0.2	✓	175	0.10	0.8	■	135	0.09	0.8	-	-	-	-	-	-	-	-	
	T8315	0.2	✓	160	0.10	0.8	■	95	0.09	0.8	✓	150	0.10	0.8	✓	480	0.12	0.8	-
	T8330	0.2	■	150	0.10	0.8	■	90	0.09	0.8	✓	140	0.10	0.8	✓	450	0.12	0.8	-
	T8430	0.2	■	185	0.10	0.8	■	100	0.09	0.8	✓	150	0.10	0.8	✓	510	0.12	0.8	-
	T9315	0.2	■	255	0.10	0.8	-	-	-	-	✓	240	0.10	0.8	-	-	-	-	-
	T9325	0.2	■	230	0.10	0.8	■	135	0.09	0.8	✓	215	0.10	0.8	-	-	-	-	-



Kesme hızı (vc), ilerleme (f) ve kesme derinliği (ap) için uygunluk ve başlangıç değerleri. Daha ileri hesaplamalar için İşleme Hesaplayıcısı uygulamasına başvurun.

Product	RE (mm)	P			M			K			N			S			H		
		vc (m/min)	f (mm/rev)	ap (mm)	vc (m/min)	f (mm/rev)	ap (mm)	vc (m/min)	f (mm/rev)	ap (mm)	vc (m/min)	f (mm/rev)	ap (mm)	vc (m/min)	f (mm/rev)	ap (mm)	vc (m/min)	f (mm/rev)	ap (mm)

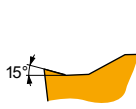

FM geometri, finiştan yarı kaba işleme, ve darbesizden hafif darbeli kesmeye kadar uygun.

DCMT 070204E-FM	T7325	0.4	155	0.17	0.8	120	0.15	0.8	-	-	-	-	-	-	-	-	-	-
	T7335	0.4	155	0.17	0.8	120	0.15	0.8	-	-	-	-	-	-	-	-	-	-
	T8315	0.4	160	0.12	0.8	95	0.11	0.8	150	0.12	0.8	480	0.14	0.8	-	-	-	-
	T8330	0.4	150	0.12	0.8	90	0.11	0.8	140	0.12	0.8	450	0.14	0.8	-	-	-	-
	T8430	0.4	185	0.12	0.8	100	0.11	0.8	150	0.12	0.8	510	0.14	0.8	-	-	-	-
	T9315	0.4	255	0.12	0.8	-	-	-	240	0.12	0.8	-	-	-	-	-	-	-
DCMT 11T302E-FM	T7325	0.2	175	0.10	0.8	135	0.09	0.8	-	-	-	-	-	-	-	-	-	-
	T8315	0.2	160	0.10	0.8	95	0.09	0.8	150	0.10	0.8	480	0.12	0.8	-	-	-	-
	T8330	0.2	150	0.10	0.8	90	0.09	0.8	140	0.10	0.8	450	0.12	0.8	-	-	-	-
	T8430	0.2	185	0.10	0.8	100	0.09	0.8	150	0.10	0.8	510	0.12	0.8	-	-	-	-
	T9315	0.2	255	0.10	0.8	-	-	-	240	0.10	0.8	-	-	-	-	-	-	-
	T9325	0.2	230	0.10	0.8	135	0.09	0.8	215	0.10	0.8	-	-	-	-	-	-	-
DCMT 11T304E-FM	T7325	0.4	155	0.17	0.8	120	0.15	0.8	-	-	-	-	-	-	-	-	-	-
	T7335	0.4	155	0.17	0.8	120	0.15	0.8	-	-	-	-	-	-	-	-	-	-
	T8315	0.4	160	0.12	0.8	95	0.11	0.8	150	0.12	0.8	480	0.14	0.8	-	-	-	-
	T8330	0.4	135	0.17	0.8	80	0.15	0.8	125	0.17	0.8	405	0.20	0.8	-	-	-	-
	T8430	0.4	155	0.17	0.8	85	0.15	0.8	130	0.17	0.8	435	0.20	0.8	-	-	-	-
	T9310	0.4	285	0.12	0.8	-	-	-	270	0.12	0.8	-	-	-	-	-	-	-
DCMT 11T308E-FM	T7325	0.8	185	0.17	0.8	140	0.15	0.8	-	-	-	-	-	-	-	-	-	-
	T7335	0.8	180	0.17	0.8	140	0.15	0.8	-	-	-	-	-	-	-	-	-	-
	T8315	0.8	170	0.17	0.8	100	0.15	0.8	160	0.17	0.8	510	0.20	0.8	-	-	-	-
	T8330	0.8	165	0.17	0.8	95	0.15	0.8	155	0.17	0.8	495	0.20	0.8	-	-	-	-
	T8430	0.8	190	0.17	0.8	105	0.15	0.8	155	0.17	0.8	525	0.20	0.8	-	-	-	-
	T9310	0.8	285	0.17	0.8	-	-	-	270	0.17	0.8	-	-	-	-	-	-	-
DCMT 11T312E-FM	T8330	1.2	150	0.22	1.2	90	0.22	1.2	140	0.22	1.2	450	0.26	1.2	-	-	-	-
	T8430	1.2	175	0.22	1.2	95	0.22	1.2	140	0.22	1.2	480	0.26	1.2	-	-	-	-
	T9315	1.2	235	0.22	1.2	-	-	-	220	0.22	1.2	-	-	-	-	-	-	-
	T9325	1.2	210	0.22	1.2	125	0.22	1.2	195	0.22	1.2	-	-	-	-	-	-	-

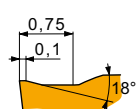

FM2 geometri, finiştan orta işleme kadar, ve darbesizden darbeli kesmeye kadar uygun.

DCMT 070204E-FM2	T6310	0.4	135	0.12	0.8	95	0.11	0.8	105	0.12	0.8	-	-	-	-	-	-	-
	T7325	0.4	160	0.12	0.8	120	0.11	0.8	-	-	-	-	-	-	-	-	-	-
	T8330	0.4	135	0.12	0.8	80	0.11	0.8	125	0.12	0.8	-	-	-	-	-	-	-
	T8430	0.4	170	0.12	0.8	90	0.11	0.8	135	0.12	0.8	-	-	-	-	-	-	-
	T9315	0.4	230	0.12	0.8	-	-	-	215	0.12	0.8	-	-	-	-	-	-	-
DCMT 11T304E-FM2	T9325	0.4	205	0.12	0.8	120	0.11	0.8	190	0.12	0.8	-	-	-	-	-	-	-
	T6310	0.4	135	0.12	0.8	95	0.11	0.8	105	0.12	0.8	-	-	-	-	-	-	-
	T7325	0.4	160	0.12	0.8	120	0.11	0.8	-	-	-	-	-	-	-	-	-	-
	T8330	0.4	135	0.12	0.8	80	0.11	0.8	125	0.12	0.8	-	-	-	-	-	-	-
	T8430	0.4	170	0.12	0.8	90	0.11	0.8	135	0.12	0.8	-	-	-	-	-	-	-
	T9315	0.4	230	0.12	0.8	-	-	-	215	0.12	0.8	-	-	-	-	-	-	-
DCMT 11T304E-FM2	T9325	0.4	205	0.12	0.8	120	0.11	0.8	190	0.12	0.8	-	-	-	-	-	-	-
	T9335	0.4	175	0.12	0.8	105	0.11	0.8	-	-	-	-	-	-	-	-	-	-



Kesme hızı (vc), ilerleme (f) ve kesme derinliği (ap) için uygunluk ve başlangıç değerleri. Daha ileri hesaplamalar için İşleme Hesaplayıcısı uygulamasına başvurun.

Product	RE  (mm)	P			M			K			N			S			H		
		vc (m/min)	f (mm/rev)	ap (mm)	vc (m/min)	f (mm/rev)	ap (mm)	vc (m/min)	f (mm/rev)	ap (mm)	vc (m/min)	f (mm/rev)	ap (mm)	vc (m/min)	f (mm/rev)	ap (mm)	vc (m/min)	f (mm/rev)	ap (mm)

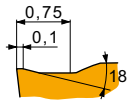

FM2 geometri, finiştin orta işleme kadar, ve darbesizden darbeli kesmeye kadar uygun.

DCMT 11T308E-FM2	T6310	0.8	█	150	0.17	0.8	█	105	0.15	0.8	█	120	0.17	0.8	–	–	–	–	–	–
	T7325	0.8	█	170	0.17	0.8	█	130	0.15	0.8	–	–	–	–	–	–	–	–	–	–
	T8330	0.8	█	150	0.17	0.8	█	90	0.15	0.8	█	140	0.17	0.8	–	–	–	–	–	–
	T8430	0.8	█	175	0.17	0.8	█	95	0.15	0.8	█	140	0.17	0.8	–	–	–	–	–	–
	T9315	0.8	█	235	0.17	0.8	–	–	–	–	█	220	0.17	0.8	–	–	–	–	–	–
	T9325	0.8	█	215	0.17	0.8	█	125	0.15	0.8	█	200	0.17	0.8	–	–	–	–	–	–
	T9335	0.8	█	180	0.17	0.8	█	105	0.15	0.8	–	–	–	–	–	–	–	–	–	–
DCMT 11T312E-FM2	T8430	1.2	█	155	0.22	1.2	█	85	0.20	1.2	█	130	0.22	1.2	–	–	–	–	–	–
	T9325	1.2	█	190	0.22	1.2	█	110	0.20	1.2	█	180	0.22	1.2	–	–	–	–	–	–
DCMT 150408E-FM2	T9315	0.8	█	205	0.20	1.5	–	–	–	–	█	190	0.20	1.5	–	–	–	–	–	–
	T9325	0.8	█	185	0.20	1.5	█	110	0.18	1.5	█	175	0.20	1.5	–	–	–	–	–	–
	T9335	0.8	█	160	0.20	1.5	█	95	0.18	1.5	–	–	–	–	–	–	–	–	–	

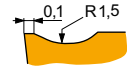

RF geometri, yarı kabadan kaba işleme kadar, ve darbesizden darbeli kesime kadar uygun.

DCMT 11T304E-RF	T5315	0.4	█	175	0.20	0.8	–	–	–	–	█	165	0.20	0.8	–	–	–	–	█	35	0.15	1.0	
	T7335	0.4	█	115	0.20	0.8	█	85	0.18	0.8	–	–	–	–	–	–	–	–	–	–	–		
	T9325	0.4	█	150	0.20	0.8	█	90	0.18	0.8	█	140	0.20	0.8	–	–	–	–	–	–	–		
DCMT 11T308E-RF	T5315	0.8	█	205	0.20	0.8	–	–	–	–	█	190	0.20	0.8	–	–	–	–	–	█	40	0.15	1.0
	T7335	0.8	█	140	0.20	0.8	█	105	0.18	0.8	–	–	–	–	–	–	–	–	–	–	–		
	T9325	0.8	█	175	0.20	0.8	█	105	0.18	0.8	█	165	0.20	0.8	–	–	–	–	–	–	–		

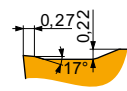

RM geometri, yarı kabadan kaba işleme kadar, ve darbesizden darbeli kesime kadar uygun.

DCMT 11T304E-RM	T5305	0.4	█	225	0.27	0.8	–	–	–	–	█	210	0.27	0.8	–	–	–	–	–	█	45	0.15	1.0	
	T5315	0.4	█	205	0.27	0.8	–	–	–	–	█	190	0.27	0.8	–	–	–	–	–	–	█	40	0.15	1.0
	T7335	0.4	█	135	0.27	0.8	█	105	0.24	0.8	–	–	–	–	█	40	0.19	0.6	–	–	–	–		
	T8330	0.4	█	125	0.27	0.8	█	75	0.24	0.8	█	115	0.27	0.8	–	–	–	–	–	█	30	0.19	0.6	
	T8430	0.4	█	135	0.27	0.8	█	75	0.24	0.8	█	110	0.27	0.8	–	–	–	–	–	█	25	0.19	0.6	
	T9315	0.4	█	185	0.27	0.8	–	–	–	–	█	175	0.27	0.8	–	–	–	–	–	–	█	35	0.15	1.0
	T9325	0.4	█	165	0.27	0.8	█	95	0.24	0.8	█	155	0.27	0.8	–	–	–	–	–	–	█	35	0.19	0.6
DCMT 11T308E-RM	T5305	0.8	█	270	0.27	0.8	–	–	–	–	█	255	0.27	0.8	–	–	–	–	–	–	█	50	0.15	1.0
	T5315	0.8	█	240	0.27	0.8	–	–	–	–	█	225	0.27	0.8	–	–	–	–	–	–	█	45	0.15	1.0
	T7335	0.8	█	165	0.27	0.8	█	125	0.24	0.8	–	–	–	–	█	50	0.19	0.6	–	–	–	–		
	T8330	0.8	█	150	0.27	0.8	█	90	0.24	0.8	█	140	0.27	0.8	–	–	–	–	–	█	35	0.19	0.6	
	T8430	0.8	█	165	0.27	0.8	█	90	0.24	0.8	█	135	0.27	0.8	–	–	–	–	–	█	35	0.19	0.6	
	T9315	0.8	█	220	0.27	0.8	–	–	–	–	█	205	0.27	0.8	–	–	–	–	–	–	█	40	0.15	1.0
	T9325	0.8	█	200	0.27	0.8	█	120	0.24	0.8	█	190	0.27	0.8	–	–	–	–	–	–	█	45	0.19	0.6
DCMT 11T312E-RM	T7335	1.2	█	165	0.27	1.2	█	125	0.24	1.2	–	–	–	–	█	50	0.19	1.2	–	–	–	–		
	T8330	1.2	█	150	0.27	1.2	█	90	0.24	1.2	█	140	0.27	1.2	–	–	–	–	–	█	30	0.15	1.0	
	T8430	1.2	█	170	0.27	1.2	█	90	0.24	1.2	█	135	0.27	1.2	–	–	–	–	–	█	35	0.19	1.2	
	T9315	1.2	█	225	0.27	1.2	–	–	–	–	█	210	0.27	1.2	–	–	–	–	–	–	█	45	0.15	1.0
	T9325	1.2	█	200	0.27	1.2	█	120	0.24	1.2	█	190	0.27	1.2	–	–	–	–	–	–	█	45	0.19	1.2
DCMT 150408E-RM	T8330	0.8	█	135	0.27	1.9	█	80	0.24	1.9	█	125	0.27	1.9	–	–	–	–	–	█	30	0.22	1.5	
	T8430	0.8	█	150	0.27	1.9	█	80	0.24	1.9	█	125	0.27	1.9	–	–	–	–	–	█	30	0.22	1.5	
	T9315	0.8	█	200	0.27	1.9	–	–	–	–	█	190	0.27	1.9	–	–	–	–	–	–	█	40	0.15	1.0
	T9325	0.8	█	180	0.27	1.9	█	105	0.24	1.9	█	170	0.27	1.9	–	–	–	–	–	–	█	40	0.22	1.5



Kesme hızı (vc), ilerleme (f) ve kesme derinliği (ap) için uygunluk ve başlangıç değerleri. Daha ileri hesaplamalar için İşleme Hesaplayıcısı uygulamasına başvurun.

Product	RE (mm)	P			M			K			N			S			H		
		vc (m/min)	f (mm/rev)	ap (mm)	vc (m/min)	f (mm/rev)	ap (mm)	vc (m/min)	f (mm/rev)	ap (mm)	vc (m/min)	f (mm/rev)	ap (mm)	vc (m/min)	f (mm/rev)	ap (mm)	vc (m/min)	f (mm/rev)	ap (mm)

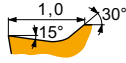

UR geometri, inceden finişe kadar işleme için, ve darbesiz ve hafif darbeleri kesim.

DCMT 070202E-UR	T7325	0.2	150	0.10	0.8	115	0.09	0.8	-	-	-	-	-	-	-	-	-	-
	T8315	0.2	135	0.10	0.8	80	0.09	0.8	125	0.10	0.8	-	-	-	-	-	-	-
	T8330	0.2	130	0.10	0.8	75	0.09	0.8	120	0.10	0.8	-	-	-	-	-	-	-
	T8430	0.2	155	0.10	0.8	85	0.09	0.8	130	0.10	0.8	-	-	-	-	-	-	-
	T9315	0.2	220	0.10	0.8	-	-	-	205	0.10	0.8	-	-	-	-	-	-	-
	T9325	0.2	200	0.10	0.8	120	0.09	0.8	190	0.10	0.8	-	-	-	-	-	-	-
DCMT 070204E-UR	T7325	0.4	135	0.17	0.8	105	0.15	0.8	-	-	-	-	-	-	-	-	-	-
	T8315	0.4	135	0.12	0.8	80	0.11	0.8	125	0.12	0.8	-	-	-	-	-	-	-
	T8330	0.4	130	0.12	0.8	75	0.11	0.8	120	0.12	0.8	-	-	-	-	-	-	-
	T8430	0.4	155	0.12	0.8	85	0.11	0.8	130	0.12	0.8	-	-	-	-	-	-	-
	T9315	0.4	220	0.12	0.8	-	-	-	205	0.12	0.8	-	-	-	-	-	-	-
	T9325	0.4	165	0.18	0.8	95	0.16	0.8	155	0.18	0.8	-	-	-	-	-	-	-
DCMT 11T302E-UR	T7325	0.2	150	0.10	0.8	115	0.09	0.8	-	-	-	-	-	-	-	-	-	-
	T8330	0.2	130	0.10	0.8	75	0.09	0.8	120	0.10	0.8	-	-	-	-	-	-	-
	T8430	0.2	155	0.10	0.8	85	0.09	0.8	130	0.10	0.8	-	-	-	-	-	-	-
	T9315	0.2	220	0.10	0.8	-	-	-	205	0.10	0.8	-	-	-	-	-	-	-
	T9325	0.2	200	0.10	0.8	120	0.09	0.8	190	0.10	0.8	-	-	-	-	-	-	-
	TT310	0.2	210	0.10	0.8	125	0.09	0.8	-	-	-	-	-	-	-	-	-	-
DCMT 11T304E-UR	T5315	0.4	220	0.12	0.8	-	-	-	205	0.12	0.8	-	-	-	-	-	-	-
	T7325	0.4	135	0.17	0.8	105	0.15	0.8	-	-	-	-	-	-	-	-	-	-
	T7335	0.4	130	0.17	0.8	100	0.15	0.8	-	-	-	-	-	-	-	-	-	-
	T8315	0.4	135	0.12	0.8	80	0.11	0.8	125	0.12	0.8	-	-	-	-	-	-	-
	T8330	0.4	130	0.12	0.8	75	0.11	0.8	120	0.12	0.8	-	-	-	-	-	-	-
	T8430	0.4	155	0.12	0.8	85	0.11	0.8	130	0.12	0.8	-	-	-	-	-	-	-
	T9315	0.4	220	0.12	0.8	-	-	-	205	0.12	0.8	-	-	-	-	-	-	-
	T9325	0.4	165	0.18	0.8	95	0.16	0.8	155	0.18	0.8	-	-	-	-	-	-	-
	TT310	0.4	210	0.12	0.8	125	0.11	0.8	-	-	-	-	-	-	-	-	-	-
	DCMT 11T308E-UR	T5315	0.8	230	0.17	0.8	-	-	-	215	0.17	0.8	-	-	-	-	-	-
T7325		0.8	160	0.17	0.8	120	0.15	0.8	-	-	-	-	-	-	-	-	-	-
T7335		0.8	155	0.17	0.8	120	0.15	0.8	-	-	-	-	-	-	-	-	-	-
T8315		0.8	145	0.17	0.8	85	0.15	0.8	135	0.17	0.8	-	-	-	-	-	-	-
T8330		0.8	140	0.17	0.8	80	0.15	0.8	130	0.17	0.8	-	-	-	-	-	-	-
T8430		0.8	165	0.17	0.8	90	0.15	0.8	135	0.17	0.8	-	-	-	-	-	-	-
T9315		0.8	225	0.17	0.8	-	-	-	210	0.17	0.8	-	-	-	-	-	-	-
T9325		0.8	200	0.17	0.8	120	0.15	0.8	190	0.17	0.8	-	-	-	-	-	-	-
TT310		0.8	225	0.17	0.8	135	0.15	0.8	-	-	-	-	-	-	-	-	-	-
DCMT 11T312E-UR	T9315	1.2	205	0.22	1.2	-	-	-	190	0.22	1.2	-	-	-	-	-	-	-
	T9325	1.2	180	0.22	1.2	105	0.20	1.2	170	0.22	1.2	-	-	-	-	-	-	-

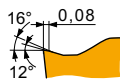

W-FM wiper geometri, inceden finişe kadar işleme, yüksek ilerleme hızları ve iyileştirilmiş yüzey finışı için.

DCMX 11T304W-FM	T7325	0.4	130	0.30	0.8	100	0.27	0.8	-	-	-	-	-	-	-	-	-
	T8330	0.4	115	0.30	0.8	65	0.27	0.8	105	0.30	0.8	-	-	-	-	-	-
	T8430	0.4	130	0.30	0.8	70	0.27	0.8	105	0.30	0.8	-	-	-	-	-	-
	T9315	0.4	170	0.30	0.8	-	-	-	160	0.30	0.8	-	-	-	-	-	-
	T9325	0.4	155	0.30	0.8	90	0.27	0.8	145	0.30	0.8	-	-	-	-	-	-
DCMX 11T308W-FM	T7325	0.8	140	0.40	1.0	105	0.36	1.0	-	-	-	-	-	-	-	-	-
	T8430	0.8	130	0.40	1.0	70	0.36	1.0	105	0.40	1.0	-	-	-	-	-	-
	T9315	0.8	175	0.40	1.0	-	-	-	165	0.40	1.0	-	-	-	-	-	-
	T9325	0.8	160	0.40	1.0	95	0.36	1.0	150	0.40	1.0	-	-	-	-	-	-



DCMW



	IC	D1	L	S
	(mm)	(mm)	(mm)	(mm)
0702	6.350	2.80	7.80	2.38
11T3	9.525	4.40	11.60	3.97

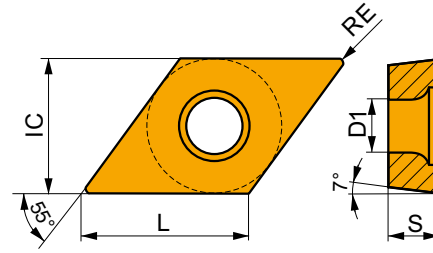

Kesme hızı (vc), ilerleme (f) ve kesme derinliği (ap) için uygunluk ve başlangıç değerleri. Daha ileri hesaplamalar için İşleme Hesaplayıcısı uygulamasına başvurun.

Product	RE	P			M			K			N			S			H		
		vc	f	ap	vc	f	ap	vc	f	ap	vc	f	ap	vc	f	ap	vc	f	ap
	(mm)	(m/min)	(mm/rev)	(mm)	(m/min)	(mm/rev)	(mm)	(m/min)	(mm/rev)	(mm)	(m/min)	(mm/rev)	(mm)	(m/min)	(mm/rev)	(mm)	(m/min)	(mm/rev)	(mm)

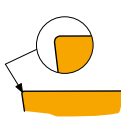

İnce finişten yarı kaba işleme kadar ve darbesizden hafif darbeli kesmeye kadar uygun.

DCMW 070202	T5305	0.2	-	-	-	-	-	-	200	0.08	0.8	-	-	-	-	-	-	40	0.15	1.0
	T6310	0.2	-	-	-	-	-	-	80	0.08	0.8	-	-	-	-	-	-	20	0.15	1.0
DCMW 070204	T5305	0.4	-	-	-	-	-	-	195	0.10	0.8	-	-	-	-	-	-	40	0.15	1.0
	T5315	0.4	-	-	-	-	-	-	175	0.10	0.8	-	-	-	-	-	-	35	0.15	1.0
	T6310	0.4	-	-	-	-	-	-	85	0.10	0.8	-	-	-	-	-	-	20	0.15	1.0
DCMW 11T304	T5305	0.4	-	-	-	-	-	-	190	0.10	1.2	-	-	-	-	-	-	40	0.15	1.0
	T5315	0.4	-	-	-	-	-	-	165	0.10	1.2	-	-	-	-	-	-	35	0.15	1.0
	T6310	0.4	-	-	-	-	-	-	80	0.10	1.2	-	-	-	-	-	-	20	0.15	1.0
DCMW 11T308	T5305	0.8	-	-	-	-	-	-	185	0.18	1.2	-	-	-	-	-	-	35	0.15	1.0
	T5315	0.8	-	-	-	-	-	-	160	0.18	1.2	-	-	-	-	-	-	30	0.15	1.0
	T6310	0.8	-	-	-	-	-	-	80	0.18	1.2	-	-	-	-	-	-	20	0.15	1.0

DCGW CBN



	IC	D1	L	S
	(mm)	(mm)	(mm)	(mm)
11T3	9.525	4.50	11.60	3.97

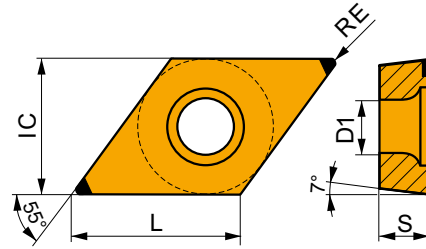

Kesme hızı (vc), ilerleme (f) ve kesme derinliği (ap) için uygunluk ve başlangıç değerleri. Daha ileri hesaplamalar için İşleme Hesaplayıcısı uygulamasına başvurun.

Product	RE	P			M			K			N			S			H		
		vc	f	ap	vc	f	ap	vc	f	ap	vc	f	ap	vc	f	ap	vc	f	ap
	(mm)	(m/min)	(mm/rev)	(mm)	(m/min)	(mm/rev)	(mm)	(m/min)	(mm/rev)	(mm)	(m/min)	(mm/rev)	(mm)	(m/min)	(mm/rev)	(mm)	(m/min)	(mm/rev)	(mm)

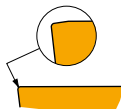

Finiş işleme için.

DCGW 11T304S01020B	TB310	0.4	-	-	-	-	-	-	370	0.10	0.4	-	-	-	95	0.07	0.3	75	0.15	1.0
DCGW 11T308S01020B	TB310	0.8	-	-	-	-	-	-	380	0.15	0.6	-	-	-	100	0.11	0.5	80	0.15	1.0



DCMW PCD

	IC	D1	L	S
	(mm)	(mm)	(mm)	(mm)
11T3	9.525	4.40	11.60	3.97

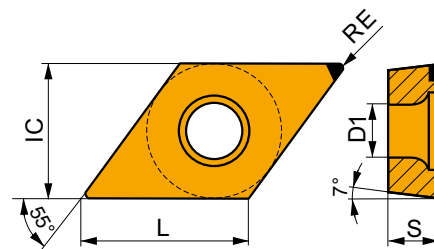

Kesme hızı (vc), ilerleme (f) ve kesme derinliği (ap) için uygunluk ve başlangıç değerleri. Daha ileri hesaplamalar için İşleme Hesaplayıcısı uygulamasına başvurun.

Product	RE	P			M			K			N			S			H			
		vc	f	ap	vc	f	ap	vc	f	ap	vc	f	ap	vc	f	ap	vc	f	ap	
	(mm)	(m/min)	(mm/rev)	(mm)	(m/min)	(mm/rev)	(mm)	(m/min)	(mm/rev)	(mm)	(m/min)	(mm/rev)	(mm)	(m/min)	(mm/rev)	(mm)	(m/min)	(mm/rev)	(mm)	

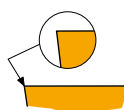
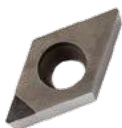

Finiş işleme, yüksek hızlı ve stabil kesme şartları için.

DCMW 11T304FN	PD1	0.4																		
DCMW 11T308FN	PD1	0.8																		



SDJC(RL) EXT

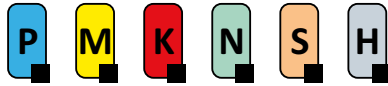

PRAMET

S

DC.. Uç için Vida Sıkmalı 93° Açılı Dış Kater

Vida sıkmalı Sağ/Sol 93° dış kater. Pozitif DC.. 07, 11 veya 15 uçlarla çap, kopya, konik ve pah tornalama için uygundur. 08x08-25x25mm shaft ölçülerinde bulunur. Gövde uzun takım ömrü için işlem görmüştür.

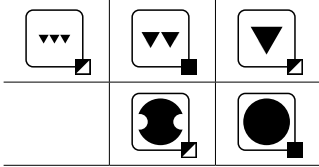
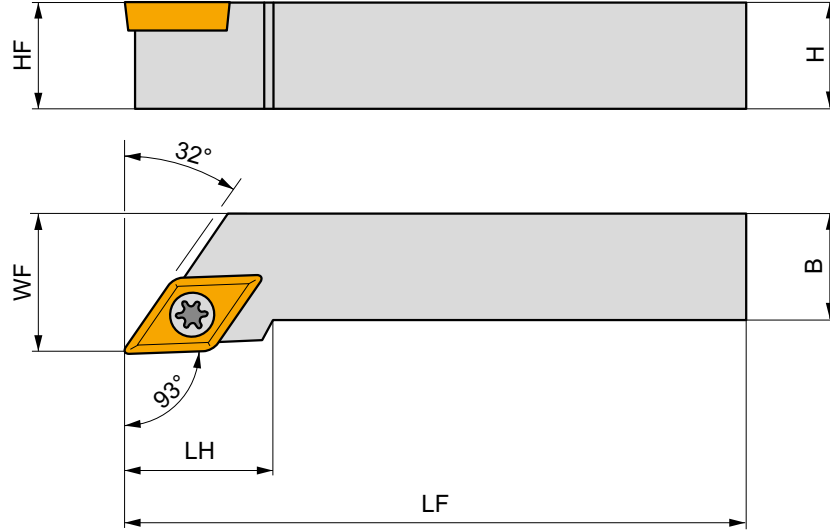
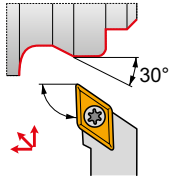

Product	H	B	HF	WF	LF	LH	LAMS	GAMO	kg	G1012	G1052
	(mm)	(mm)	(mm)	(mm)	(mm)	(mm)	(°)	(°)			
R SDJCR 0808 D 07	8	8	8	10	60	14	0	0	0.06	G1052	S01
SDJCR 1010 E 07	10	10	10	12	70	14	0	0	0.06	G1052	S01
SDJCR 1212 F 07	12	12	12	16	80	14	0	0	0.11	G1052	S01
SDJCR 1212 F 11	12	12	12	16	80	20	0	0	0.10	G1012	S08
SDJCR 1616 H 11	16	16	16	20	100	20	0	0	0.22	G1012	S08
SDJCR 2020 K 11-M-A	20	20	20	25	125	20	0	0	0.40	G1012	SD10
SDJCR 2525 M 11-M-A	25	25	25	32	150	20	0	0	0.74	G1012	SD10
SDJCR 2525 M 15	25	25	25	32	150	28	0	0	0.75	G1243	SD11
L SDJCL 0808 D 07	8	8	8	10	60	14	0	0	0.04	G1052	S01
SDJCL 1010 E 07	10	10	10	12	70	14	0	0	0.08	G1052	S01
SDJCL 1212 F 07	12	12	12	16	80	14	0	0	0.12	G1052	S01
SDJCL 1212 F 11	12	12	12	16	80	20	0	0	0.12	G1012	S08
SDJCL 1616 H 11	16	16	16	20	100	20	0	0	0.20	G1012	S08
SDJCL 2020 K 11-M-A	20	20	20	25	125	20	0	0	0.41	G1012	SD10
SDJCL 2525 M 11-M-A	25	25	25	32	150	20	0	0	0.74	G1012	SD10
SDJCL 2525 M 15	25	25	25	32	150	28	0	0	0.07	G1243	SD11



G1012

DC.. 11T3..

G1052

DC.. 0702..

G1243

DC.. 1504..



Nm



SD10

US 3510-T15P

3.0

M 3.5

10.6

SDN 110304

MS 3510

FLAG T15P

HXK 3.5

SD11

US 64518-T15P

5.0

M 4.5

18

SDN 150304

MS 4512

FLAG T15P

HXK 5

S01

US 2506-T07P

0.9

M 2.5

6.3

-

-

FLAG T07P

-

S08

US 3510-T15P

3.0

M 3.5

10.6

-

-

FLAG T15P

-



SDNCN EXT



PRAMET

S



DC.. Uç için Vida Sıklı 62.5° Açılı Dış Kater

Vida sıklı nör dış kater. Pozitif DC.. 07 veya 11 uçlarla çap, kopya, konik ve pah tormalama için uygundur. 08x08-25x25mm mevcuttur. Gövde uzun takım ömrü için işlem görmüştür.

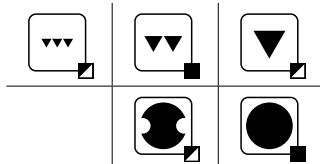
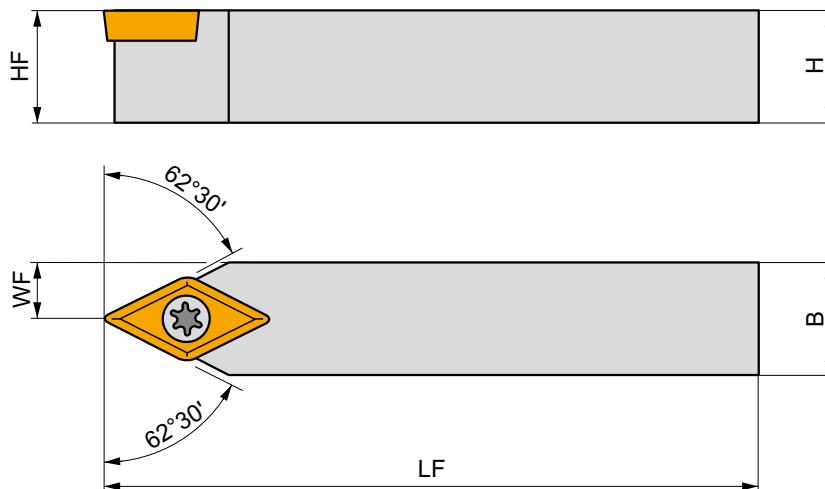
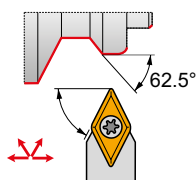

Product	H (mm)	B (mm)	HF (mm)	WF (mm)	LF (mm)	LAMS (°)	GAMO (°)	kg	GI012	GI052	SD10
N SDNCN 0808 D 07	8	8	8	4	60	0	0	0.06	GI052		S01
SDNCN 1010 E 07	10	10	10	5	70	0	0	0.08	GI052		S01
SDNCN 1212 F 07	12	12	12	6	80	0	0	0.12	GI052		S01
SDNCN 1212 F 11	12	12	12	6	80	0	0	0.12	GI012		S08
SDNCN 1616 H 11	16	16	16	8	100	0	0	0.18	GI012		S08
SDNCN 2020 K 11-M-A	20	20	20	10	125	0	0	0.35	GI012		SD10
SDNCN 2525 M 11-M-A	25	25	25	12.5	150	0	0	0.70	GI012		SD10



GI012

DC.. 11T3..

GI052

DC.. 0702..



SD10

US 3510-T15P

3.0

M 3.5

10.6

SDN 110304

MS 3510

FLAGT15P

HXK 3.5

S01

US 2506-T07P

0.9

M 2.5

6.3

-

-

FLAGT07P

-

S08

US 3510-T15P

3.0

M 3.5

10.6

-

-

FLAGT15P

-

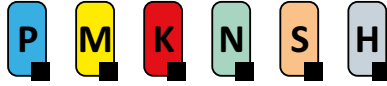
**NEW****C.-SDJC(RL) EXT**

PRAMET

S**DC.. Uç için Vida Sıkmalı, 93° Açılı Hızlı Değişirme Dış Takımı**

Vida sıkmalı Sağ/Sol, içten su vermeli 93° dış kater. Pozitif DC.. 07, 11 veya 15 uçlarla çap, kopya, konik, kopya ve pah tormalama için uygundur. PSC C3-C5 ölçülerinde bulunur. Gövde uzun takım ömrü için işlem görmüştür.

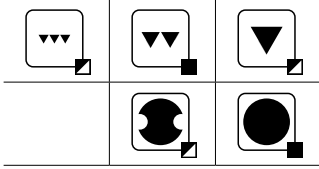
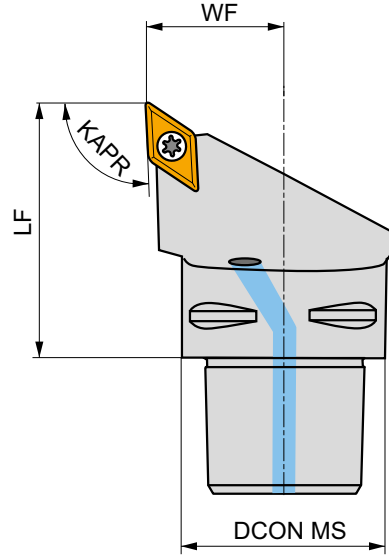
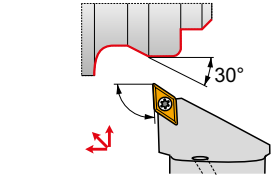

Product	DCON MS (mm)	WF (mm)	LF (mm)	KAPR (°)	LAMMS (°)	GAMO (°)	✓	kg	GI012	C-SD11V-1
R C3-SDJCR-22040-11	32	22	40	93	0	0	✓	0.21	GI012	C-SD11V-1
C4-SDJCR-27050-11	40	27	50	93	0	0	✓	0.38	GI012	C-SD11V-1
C5-SDJCR-35060-11	50	35	60	93	0	0	✓	0.69	GI012	C-SD11V-2
L C3-SDJCL-22040-11	32	22	40	93	0	0	✓	0.21	GI012	C-SD11V-1
C4-SDJCL-27050-11	40	27	50	93	0	0	✓	0.38	GI012	C-SD11V-1
C5-SDJCL-35060-11	50	35	60	93	0	0	✓	0.70	GI012	C-SD11V-2



GI012



DC.. 11T3..



Nm



M 3.5



12.1



SDS 263-01



MS 9001



FLAG T15P/3,5



CN 034-01

C-SD11V-1

US 2001-T15P

3.0

M 3.5

12.1

SDS 263-01

MS 9001

FLAG T15P/3,5

CN 034-01

C-SD11V-2

US 2001-T15P

3.0

M 3.5

12.1

SDS 263-01

MS 9001

FLAG T15P/3,5

CN 034-02

NEW
C.-SDNCN EXT

PRAMET
S

DC.. Uç için Vida Sıklı, 62.5° Açılı Hızlı Değişirme Dış Takımı

Vida sıklı Sağ/Sol, içten su vermeli 62.5° dış kater. Pozitif DC.. 11 uçlarla çap,konik, kopya ve pah tormalama için uygundur. PSC C4 ve C5 ölçülerinde bulunur. Gövde uzun takım ömrü için işlem görmüştür.

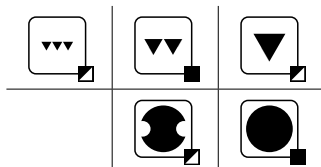
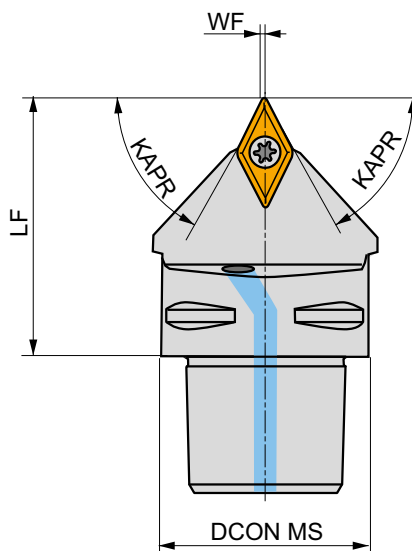
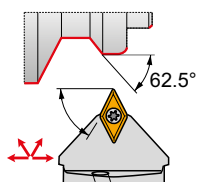

Product	DCON MS (mm)	WF (mm)	LF (mm)	KAPR (°)	LAMS (°)	GAMO (°)				
N C4-SDNCN-00050-11	40	0.5	50	62.5	0	0	✓	0.35	GI012	C-SD11V-1
C5-SDNCN-00060-11	50	0.5	60	62.5	0	0	✓	0.62	GI012	C-SD11V-2



GI012



DC.. 11T3..

C-SD11V-1	US 2001-T15P	3.0	M 3.5	12.1	SDS 263-01	MS 9001	FLAG T15P/3,5	CN 034-01
C-SD11V-2	US 2001-T15P	3.0	M 3.5	12.1	SDS 263-01	MS 9001	FLAG T15P/3,5	CN 034-02



SDQC(RL) INT

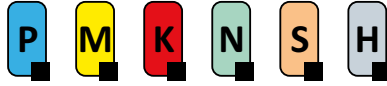

PRAMET

S



DC.. Uç için Vida Sıkmalı 107.5° Açılı Delik Kateri

Vida sıkmalı Sağ/Sol 107.5° delik kateri. Pozitif DC.. 07 veya 11 uçlarla minimum Ø13mm çap, konik, ve pah tornalama için uygundur. Ø10-32mm shaft ölçülerinde bulunur. Gövde uzun takım ömrü için işlem görmüştür.

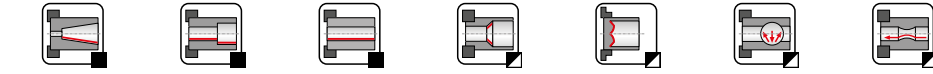
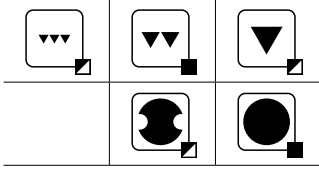
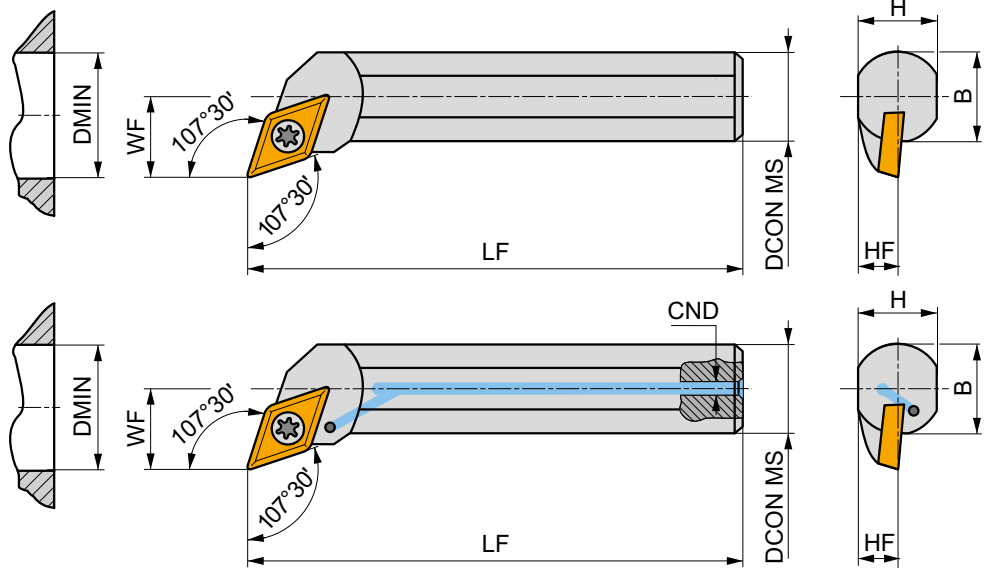
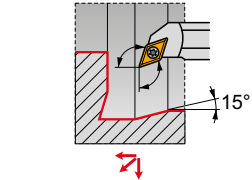

Product	DCON MS (mm)	DMIN (mm)	WF (mm)	H (mm)	B (mm)	LF (mm)	CND (mm)	LAMS (°)	GAMO (°)	✓	kg	GI052	S02
R A10H-SDQCR 07	10	13	7	9	-	100	4	-10	0	✓	0.07	GI052	S02
A12K-SDQCR 07	12	16	9	11	-	125	5	-7	0	✓	0.10	GI052	S02
A16M-SDQCR 07	16	20	11	14.5	-	150	6	-7	0	✓	0.24	GI052	S01
A20Q-SDQCR 11	20	25	13	18	-	180	8	-5	0	✓	0.40	GI012	S08
S20S-SDQCR 11	20	25	13	18	18.5	250	-	-5	0	-	0.60	GI012	S08
A25R-SDQCR 11	25	32	17	23	23	200	8	-3	0	✓	0.67	GI012	S08
S25T-SDQCR 11	25	32	17	23	23	300	-	-3	0	-	1.09	GI012	S08
A32S-SDQCR 11-A	32	40	22	30	30	250	8	-10	0	✓	1.25	GI012	SD10
S32U-SDQCR 11-A	32	40	22	30	30	350	-	-10	0	-	2.10	GI012	SD10
L A10H-SDQCL 07	10	13	7	9	-	100	4	-10	0	✓	0.06	GI052	S02
A12K-SDQCL 07	12	16	9	11	-	125	5	-7	0	✓	0.11	GI052	S02
A16M-SDQCL 07	16	20	11	14.5	-	150	6	-7	0	✓	0.24	GI052	S01
A20Q-SDQCL 11	20	25	13	18	-	180	8	-5	0	✓	0.37	GI012	S08
S20S-SDQCL 11	20	25	13	18	18.5	250	-	-5	0	-	0.63	GI012	S08
A25R-SDQCL 11	25	32	17	23	23	200	8	-3	0	✓	0.64	GI012	S08
S25T-SDQCL 11	25	32	17	23	23	300	-	-3	0	-	1.15	GI012	S08
A32S-SDQCL 11-A	32	40	22	30	30	250	8	-10	0	✓	1.33	GI012	SD10
S32U-SDQCL 11-A	32	40	22	30	30	350	-	-10	0	-	2.08	GI012	SD10



GI012
GI052

DC.. 11T3..
DC.. 0702..



SD10
S01
S02
S08

US 3510-T15P
US 2506-T07P
US 2505-T07P
US 3510-T15P

3.0
0.9
0.9
3.0

M 3.5
M 2.5
M 2.5
M 3.5

10.6
6.3
5.2
10.6

SDN 110304
-
-
-

MS 3510
-
-
-

FLAG T15P
FLAG T07P
FLAG T07P
FLAG T15P

HXK 3.5
-
-
-



SDUC(RL) INT



PRAMET

S



DC.. Uç için Vida Sıklı 93° Açılı Delik Kateri

Vida sıklı Sağ/Sol 93° için su vermeli delik kateri. Pozitif DC.. 07 veya 11 uçlarla minimum Ø13mm çap, konik, kopya ve pah tornalama için uygundur. Ø10-32mm şaft ölçülerinde bulunur. Gövde uzun takım ömrü için işlem görmüştür.

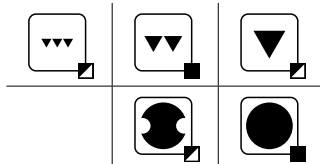
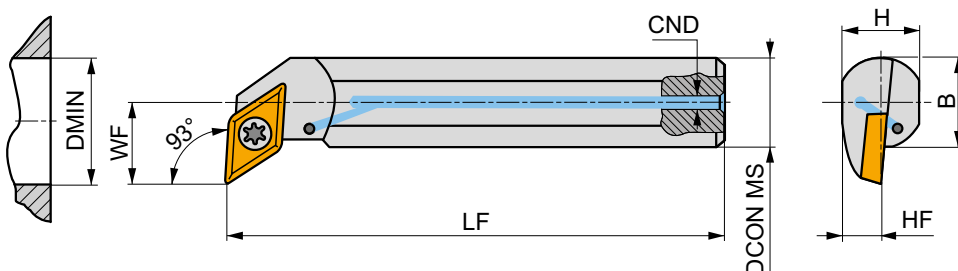
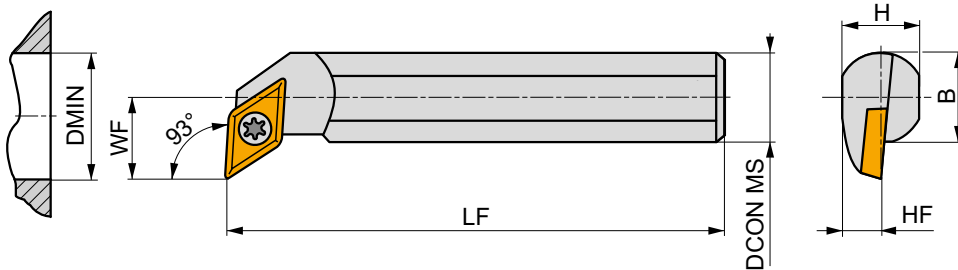
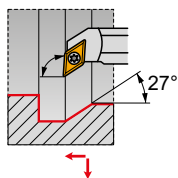

Product	DCON MS	DMIN	WF	H	B	LF	CND	LAMS	GAMO	kg	GI052	S02		
	(mm)	(mm)	(mm)	(mm)	(mm)	(mm)	(mm)	(°)	(°)					
R	A10H-SDUCR 07	10	13	7	9	-	100	4	-10	0	✓	0.05	GI052	S02
	A12K-SDUCR 07	12	16	9	11	-	125	5	-7	0	✓	0.12	GI052	S02
	A16M-SDUCR 07	16	20	11	14.5	-	150	6	-7	0	✓	0.22	GI052	S01
	A20Q-SDUCR 11	20	25	13	18	-	180	8	-3	0	✓	0.38	GI012	S08
	S20S-SDUCR 11	20	25	13	18	18.5	250	-	-5	0	-	0.60	GI012	S08
	A25R-SDUCR 11	25	32	17	23	23	200	8	-3	0	✓	0.60	GI012	S08
	S25T-SDUCR 11	25	32	17	23	23	300	-	-3	0	-	1.15	GI012	S08
	A32S-SDUCR 11-A	32	40	22	30	30	250	8	-10	0	✓	1.30	GI012	SD10
	S32U-SDUCR 11-A	32	40	22	30	30	350	-	-10	0	-	2.10	GI012	SD10
L	A10H-SDUCL 07	10	13	7	9	-	100	4	-10	0	✓	0.06	GI052	S02
	A12K-SDUCL 07	12	16	9	11	-	125	5	-7	0	✓	0.11	GI052	S02
	A16M-SDUCL 07	16	20	11	14.5	-	150	6	-7	0	✓	0.21	GI052	S01
	A20Q-SDUCL 11	20	25	13	18	-	180	8	-3	0	✓	0.38	GI012	S08
	S20S-SDUCL 11	20	25	13	18	18.5	250	-	-5	0	-	0.60	GI012	S08
	A25R-SDUCL 11	25	32	17	23	23	200	8	-3	0	✓	0.67	GI012	S08
	S25T-SDUCL 11	25	32	17	23	23	300	-	-3	0	-	1.15	GI012	S08
	A32S-SDUCL 11-A	32	40	22	30	30	250	8	-10	0	✓	1.35	GI012	SD10
	S32U-SDUCL 11-A	32	40	22	30	30	350	-	-10	0	-	2.09	GI012	SD10



GI012

DC.. 11T3..

GI052

DC.. 0702..



SD10

US 3510-T15P

3.0

M 3.5

10.6

SDN 110304

MS 3510

FLAG T15P

HXK 3.5

S01

US 2506-T07P

0.9

M 2.5

6.3

-

-

FLAG T07P

-

S02

US 2505-T07P

0.9

M 2.5

5.2

-

-

FLAG T07P

-

S08

US 3510-T15P

3.0

M 3.5

10.6

-

-

FLAG T15P

-



SDUC(RL)-E INT

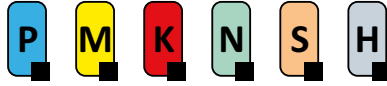

PRAMET

S



DC.. Uç için Vida Sıkmalı 93° Açılı Karbür Delik Kateri

Vida sıkmalı Sağ/Sol 93° içten su vermeli karbür delik kateri. Pozitif DC.. 07 veya 11 uçlarla minimum Ø13mm çap, konik, kopya ve pah tornalama için uygundur. Ø10-32mm shaft ölçülerinde bulunur. Gövde uzun takım ömrü için işlem görmüştür. Delik boyu > 3xD

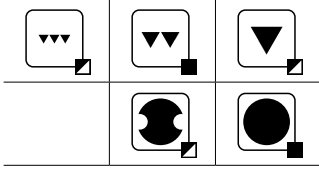
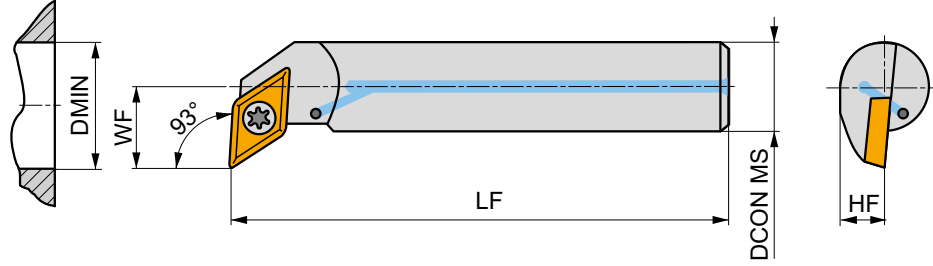
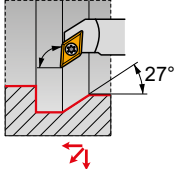

Product	DCON MS	DMIN	WF	HF	LF	LAMS	GAMO		kg			
	(mm)	(mm)	(mm)	(mm)	(mm)	(°)	(°)					
R	E10M-SDUCR 07-ER	10	15	9	5.6	150	-5	0	✓	0.14	GI052	SD21
	E12Q-SDUCR 07-ER	12	18	11	6.5	150	-5	0	✓	0.26	GI052	SD21
	E16R-SDUCR 07-ER	16	22	13	8.5	150	-5	0	✓	0.49	GI052	SD21
L	E10M-SDUCL 07-ER	10	15	9	5.6	150	-5	0	✓	0.15	GI052	SD21
	E12Q-SDUCL 07-ER	12	18	11	6.5	150	-5	0	✓	0.26	GI052	SD21
	E16R-SDUCL 07-ER	16	22	13	8.5	150	-5	0	✓	0.50	GI052	SD21



GI052



DC.. 0702..



SD21



5513 020-03



0.8



M 2.5



6.5



PT-8001



SDZC(RL) INT



PRAMET

S



DC.. Uç için Vida Sıklı 93° Açılı Delik Kateri

Vida sıklı Sağ/Sol 93° delik kateri. Pozitif DC.. 07 veya 11 uçlarla minimum Ø27mm ters pah, konik, kopya ve pah tornalama için uygundur. Ø10-12mm şaft ölçülerinde bulunur. Gövde uzun takım ömrü için işlem görmüştür.

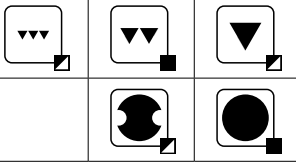
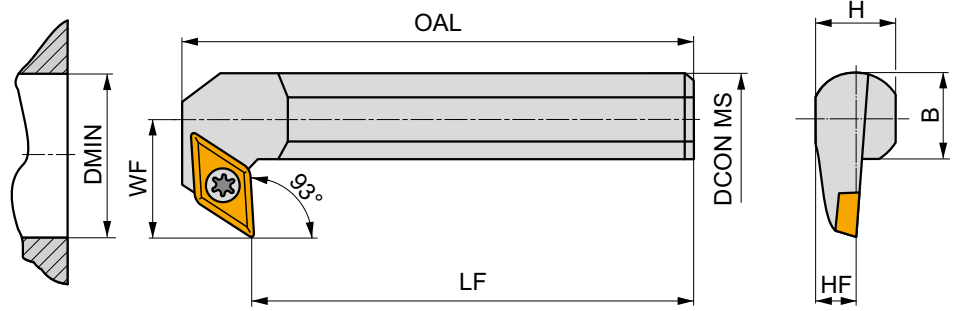
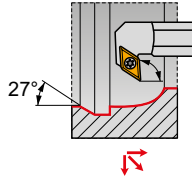

Product	DCON MS (mm)	DMIN (mm)	WF (mm)	H (mm)	B (mm)	LF (mm)	OAL (mm)	LAMS (°)	GAMO (°)	kg	G1012	G1052	S01	S08	
R	S16M-SDZCR 07-93	16	27	17	14.5	15	150	163	-4	0	0.26	G1052	S01		
	S20Q-SDZCR 11-93	20	35	22	18	18.5	180	198	-5	0	0.50	G1012	S08		
	S25R-SDZCR 11-93	25	42	27	23	23	200	218	-3	0	0.83	G1012	S08		
	S32S-SDZCR 11-93-A	32	53	35	30	30	250	268	-6	0	1.64	G1012	SD10		
	S40T-SDZCR 11-93-A	40	65	43	38	38	300	322	-5	0	3.00	G1012	SD10		
L	S16M-SDZCL 07-93	16	27	17	14.5	15	150	163	-4	0	0.27	G1052	S01		
	S20Q-SDZCL 11-93	20	35	22	18	18.5	180	198	-5	0	0.60	G1012	S08		
	S25R-SDZCL 11-93	25	42	27	23	23	200	218	-3	0	0.80	G1012	S08		
	S32S-SDZCL 11-93-A	32	53	35	30	30	250	268	-6	0	1.60	G1012	SD10		
	S40T-SDZCL 11-93-A	40	65	43	38	38	300	322	-5	0	3.00	G1012	SD10		



G1012

DC.. 11T3..

G1052

DC.. 0702..



SD10

US 3510-T15P

3.0

M 3.5

10.6

SDN 110304

MS 3510

FLAG T15P

HXK 3.5

S01

US 2506-T07P

0.9

M 2.5

6.3

-

-

FLAG T07P

-

S08

US 3510-T15P

3.0

M 3.5

10.6

-

-

FLAG T15P

-

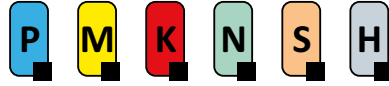
**NEW****C.-SDUC(RL) INT**

PRAMET

S**DC.. Uç için Vida Sıkmalı 93° Açılı PSC Hızlı Değişirme Delik Takımı**

Vida sıkımlı Sağ/Sol 93° içten su vermeli delik kateri. Pozitif DC.. 07 veya 11 uçlarla minimum Ø20mm çap, ve birçok çeşit tornalama için uygundur. C3-5 şaft ve çeşitli boy ölçülerinde bulunur. Gövde uzun takım ömrü için işlem görmüştür.

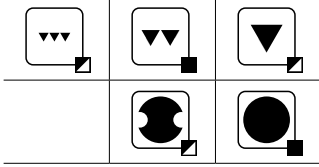
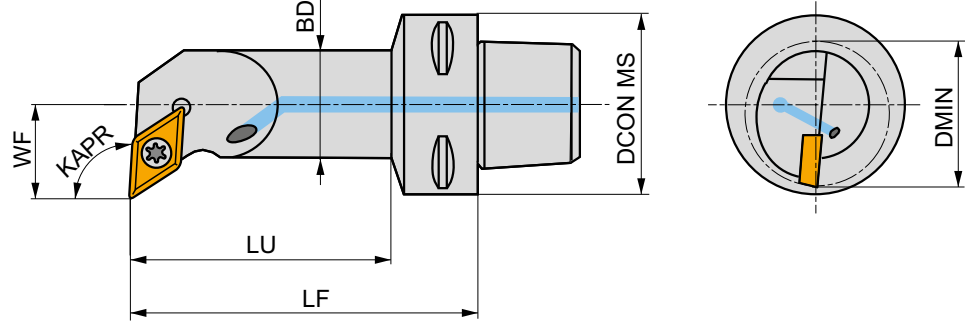
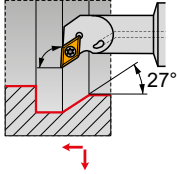

Product	DCON MS	DMIN	WF	LF	LU	BD	KAPR	LAMS	GAMO	✓	kg	GI012	SV11
	(mm)	(mm)	(mm)	(mm)	(mm)	(mm)	(°)	(°)	(°)				
R C3-SDUCR-11065-07	50	20	11	65	48	16	93	-4.3	0	✓	0.20	GI052	SV11
C4-SDUCR-11070-07	40	20	11	70	47	16	93	-4.3	0	✓	0.35	GI052	SV11
C4-SDUCR-13080-11	40	25	13	80	57	20	93	-5.8	0	✓	0.41	GI012	SC09M
C4-SDUCR-17090-11	40	32	17	90	68	25	93	-3.4	0	✓	0.49	GI012	SV16
C5-SDUCR-13080-11	50	25	13	80	56	20	93	-5.8	0	✓	0.60	GI012	SC09M
C5-SDUCR-17090-11	50	32	17	90	67	25	93	-3.4	0	✓	0.68	GI012	SV16
L C4-SDUCL-11070-07	40	20	11	70	47	16	93	-4.3	0	✓	0.35	GI052	SV11
C4-SDUCL-13080-11	40	25	13	80	57	20	93	-5.8	0	✓	0.41	GI012	SC09M
C4-SDUCL-17090-11	40	32	17	90	68	25	93	-3.4	0	✓	0.49	GI012	SV16
C5-SDUCL-13080-11	50	25	13	80	56	20	93	-5.8	0	✓	0.60	GI012	SC09M



GI012

DC.. 11T3..

GI052

DC.. 0702..



SC09M

US 2009-T15P

3.0

M 3.5

8.1

FLAG T15P/3,5

-

SV11

US 2003-T07P

0.8

M 2.5

6.5

-

FLAG T07P

SV16

US 2010-T15P

3.0

M 3.5

10.1

-

FLAG T15P/3,5



EC

06 / 08

KARBÜR UÇLAR

ECGT



104

ECMT



105

ECMW



106

DOĞRU BOYUTLA EŞLEŞTİRİN (örnek)

Kesici uç

ECMT 060204E-FM2

Takım Tutucu

S08K-SEUCR 06

ISO TORNALAMA - DIŞ

SEGC(RL) EXT

90°

EC..

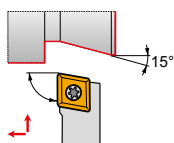

08

 $\frac{12 \times 12}{16 \times 16}$

107

104 – 106

ISO TORNALAMA - İÇ

SEUC(RL) INT

93°

EC..



06

08

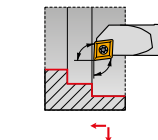
 $\frac{11}{32}$

108

104 – 106



ECGT



	IC (mm)	D1 (mm)	L (mm)	S (mm)
0602	6.350	2.80	6.50	2.38
0602-SF3	6.350	2.80	6.50	2.58
0803	7.940	3.40	8.20	3.18
0803-SF3	7.940	3.40	8.20	3.43

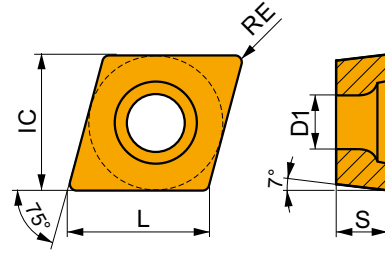

Kesme hızı (vc), ilerleme (f) ve kesme derinliği (ap) için uygunluk ve başlangıç değerleri. Daha ileri hesaplamalar için İşleme Hesaplayıcısı uygulamasına başvurun.

Product	RE (mm)	P			M			K			N			S			H		
		vc (m/min)	f (mm/rev)	ap (mm)	vc (m/min)	f (mm/rev)	ap (mm)	vc (m/min)	f (mm/rev)	ap (mm)	vc (m/min)	f (mm/rev)	ap (mm)	vc (m/min)	f (mm/rev)	ap (mm)	vc (m/min)	f (mm/rev)	ap (mm)

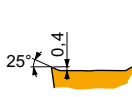

SF3 geometri, inceden finiş işlemeye kadar işlemek için çok pozitif tasarım, darbesiz kesim için uygun.

ECGT 060202E-SF2	H07	0.2	–	–	–	105	0.05	1.0	–	–	–	525	0.06	1.0	50	0.04	0.8	–	–	–
	T6310	0.2	185	0.05	1.0	130	0.05	1.0	–	–	–	555	0.06	1.0	55	0.04	0.8	–	–	–
ECGT 060204E-SF2	H07	0.4	–	–	–	85	0.09	1.0	–	–	–	430	0.12	1.0	40	0.07	0.8	–	–	–
	T6310	0.4	160	0.10	1.0	115	0.09	1.0	–	–	–	480	0.12	1.0	45	0.07	0.8	–	–	–
ECGT 080302E-SF2	H07	0.2	–	–	–	105	0.05	1.0	–	–	–	525	0.06	1.0	50	0.04	0.8	–	–	–
	T6310	0.2	185	0.05	1.0	130	0.05	1.0	–	–	–	555	0.06	1.0	55	0.04	0.8	–	–	–
ECGT 080304E-SF2	H07	0.4	–	–	–	85	0.09	1.0	–	–	–	430	0.12	1.0	40	0.07	0.8	–	–	–
	T6310	0.4	160	0.10	1.0	115	0.09	1.0	–	–	–	480	0.12	1.0	45	0.07	0.8	–	–	–

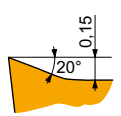

SF3 geometri, inceden finiş işlemeye kadar işlemek için çok pozitif tasarım, darbesiz kesim için uygun.

ECGT 060202E-SF3	H07	0.2	–	–	–	105	0.05	0.8	170	0.05	0.8	540	0.06	0.8	55	0.04	0.6	–	–	–
	T6310	0.2	185	0.05	0.8	130	0.05	0.8	145	0.05	0.8	555	0.06	0.8	55	0.04	0.6	35	0.15	1.0
ECGT 080304E-SF3	H07	0.4	–	–	–	85	0.09	1.0	135	0.10	1.0	430	0.12	1.0	40	0.07	0.8	–	–	–
	T6310	0.4	160	0.10	1.0	115	0.09	1.0	125	0.10	1.0	480	0.12	1.0	45	0.07	0.8	30	0.15	1.0



ECMT

	IC	D1	L	S
	(mm)	(mm)	(mm)	(mm)
0602	6.350	2.80	6.50	2.38
0803	7.940	3.40	8.20	3.18

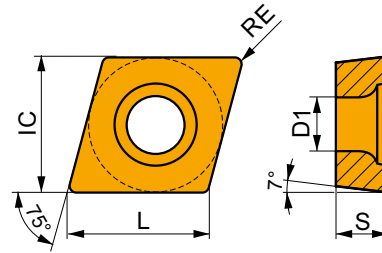

Kesme hızı (vc), ilerleme (f) ve kesme derinliği (ap) için uygunluk ve başlangıç değerleri. Daha ileri hesaplamalar için İşleme Hesaplayıcısı uygulamasına başvurun.

Product	RE	P			M			K			N			S			H		
		vc	f	ap	vc	f	ap	vc	f	ap	vc	f	ap	vc	f	ap			
	(mm)	(m/min)	(mm/rev)	(mm)	(m/min)	(mm/rev)	(mm)	(m/min)	(mm/rev)	(mm)	(m/min)	(mm/rev)	(mm)	(m/min)	(mm/rev)	(mm)	(m/min)	(mm/rev)	(mm)

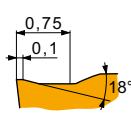
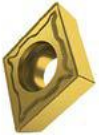

FM2 geometri, finiştin orta işlemeye kadar, ve darbesizden darbeli kesmeye kadar uygun.

ECMT 060204E-FM2	T7325	0.4	✓	180	0.12	0.8	✓	140	0.11	0.8	–	–	–	–	–	–	–	–	–
	T8330	0.4	■	155	0.12	0.8	✓	90	0.11	0.8	■	145	0.12	0.8	–	–	–	–	–
	T8430	0.4	■	205	0.12	0.8	✓	110	0.11	0.8	✓	170	0.12	0.8	–	–	–	–	–
	T9315	0.4	■	290	0.12	0.8	–	–	–	–	✓	275	0.12	0.8	–	–	–	–	–
	T9325	0.4	■	255	0.12	0.8	✓	150	0.11	0.8	✓	240	0.12	0.8	–	–	–	–	–
	T9335	0.4	■	220	0.12	0.8	✓	130	0.11	0.8	–	–	–	–	–	–	–	–	–
ECMT 080304E-FM2	T5315	0.4	✓	280	0.12	1.0	–	–	–	■	265	0.12	1.0	–	–	–	–	–	–
	T7325	0.4	✓	170	0.12	1.0	✓	130	0.11	1.0	–	–	–	–	–	–	–	–	
	T8330	0.4	■	150	0.12	1.0	✓	90	0.11	1.0	■	140	0.12	1.0	–	–	–	–	–
	T8430	0.4	■	205	0.12	1.0	✓	110	0.11	1.0	✓	170	0.12	1.0	–	–	–	–	–
	T9315	0.4	■	280	0.12	1.0	–	–	–	–	✓	265	0.12	1.0	–	–	–	–	–
	T9325	0.4	■	255	0.12	1.0	✓	150	0.11	1.0	✓	240	0.12	1.0	–	–	–	–	–
T9335	0.4	■	215	0.12	1.0	✓	125	0.11	1.0	–	–	–	–	–	–	–	–	–	
ECMT 080308E-FM2	T7325	0.8	✓	185	0.17	1.0	✓	140	0.15	1.0	–	–	–	–	–	–	–	–	
	T8330	0.8	■	165	0.17	1.0	✓	95	0.15	1.0	■	155	0.17	1.0	–	–	–	–	–
	T8430	0.8	■	210	0.17	1.0	✓	115	0.15	1.0	✓	175	0.17	1.0	–	–	–	–	–
	T9315	0.8	■	290	0.17	1.0	–	–	–	–	✓	275	0.17	1.0	–	–	–	–	–
	T9325	0.8	■	260	0.17	1.0	✓	155	0.15	1.0	✓	245	0.17	1.0	–	–	–	–	–
	T9335	0.8	■	225	0.17	1.0	✓	135	0.15	1.0	–	–	–	–	–	–	–	–	–



ECMW



	IC	D1	L	S
	(mm)	(mm)	(mm)	(mm)
0602	6.350	2.80	6.50	2.38
0803	7.940	3.40	8.20	3.18

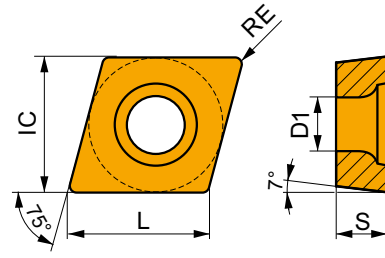

Kesme hızı (vc), ilerleme (f) ve kesme derinliği (ap) için uygunluk ve başlangıç değerleri. Daha ileri hesaplamalar için İşleme Hesaplayıcısı uygulamasına başvurun.

Product	RE (mm)	P			M			K			N			S			H		
		vc (m/min)	f (mm/rev)	ap (mm)	vc (m/min)	f (mm/rev)	ap (mm)	vc (m/min)	f (mm/rev)	ap (mm)	vc (m/min)	f (mm/rev)	ap (mm)	vc (m/min)	f (mm/rev)	ap (mm)	vc (m/min)	f (mm/rev)	ap (mm)

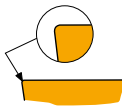

İnce finiştan yarı kaba işleme kadar ve darbesizden hafif darbeli kesmeye kadar uygun.

ECMW 060204	H07	0.4	-	-	-	-	-	-	100	0.10	2.0	-	-	-	-	-	-	-	-
ECMW 080304	H07	0.4	-	-	-	-	-	-	100	0.10	2.5	-	-	-	-	-	-	-	-
ECMW 080308	H07	0.8	-	-	-	-	-	-	95	0.18	2.5	-	-	-	-	-	-	-	-



SEGC(RL) EXT



PRAMET

S



EC.. Uç için Vida Sıkmalı 90° Açılı Dış Kater

Vida sıkmalı Sağ/Sol 90° dış kater. Pozitif EC.. 08 uçlarla çap, konik ve pah tormalama için uygundur. 12x12 ve 16x16mm shaft ölçülerinde bulunur. Gövde uzun takım ömrü için işlem görmüştür.

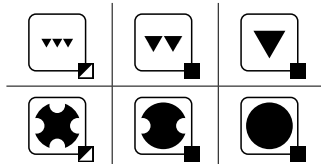
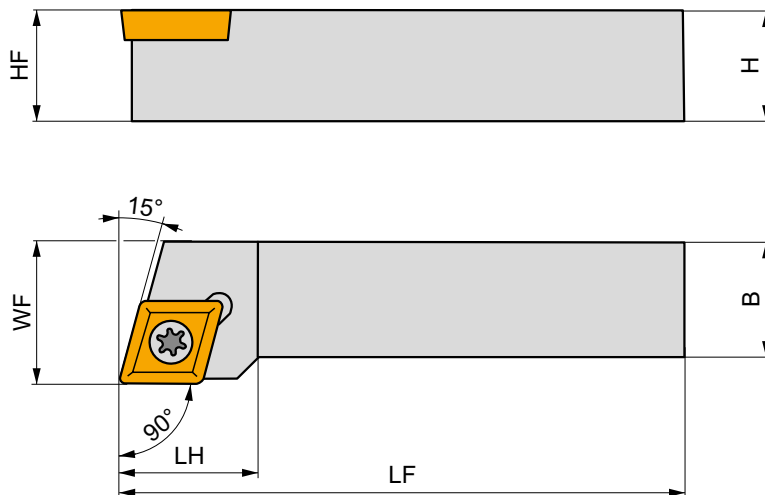
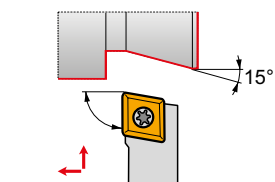

Product	H	B	HF	WF	LF	LH	LAMS	GAMO	kg	GI210	SE08	
	(mm)	(mm)	(mm)	(mm)	(mm)	(mm)	(°)	(°)				
R	SEGCR 1212 N 08	12	12	12	16	160	12	0	0	0.15	GI210	SE08
	SEGCR 1616 H 08	16	16	16	20	100	12	0	0	0.22	GI210	SE08
L	SEGCL 1212 N 08	12	12	12	16	160	12	0	0	0.22	GI210	SE08
	SEGCL 1616 H 08	16	16	16	20	100	12	0	0	2.14	GI210	SE08



GI210



EC.. 0803..



SE08



416.1-832



3.6



M3



8.5



PT-8002



SEUC(RL) INT

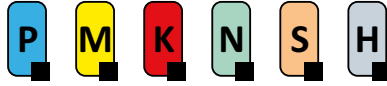

PRAMET

S



EC.. Uç için Vida Sıkmalı 93° Açılı Delik Kateri

Vida sıkmalı Sağ/Sol 93° delik kateri. Pozitif EC.. 06 veya 08 uçlarla minimum Ø11mm çap, konik, ve pah tornalama için uygundur. Ø8-25mm shaft ölçülerinde bulunur. Gövde uzun takımı için işlem görmüştür.

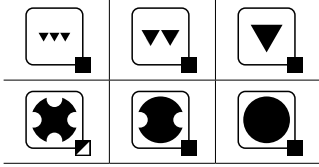
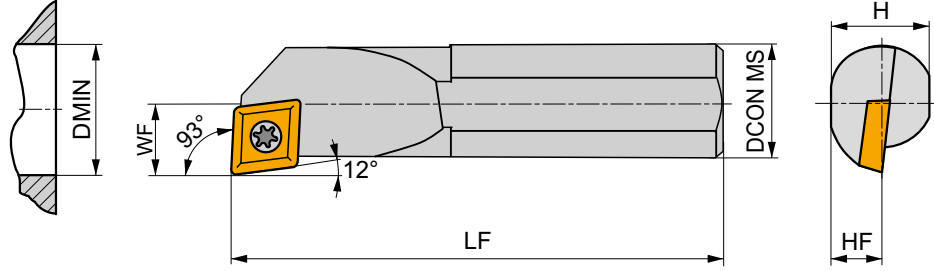
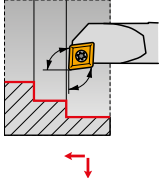

Product	DCON MS	DMIN	WF	H	HF	LF	LAMS	GAMO	kg	G120	G123	SE23	SE24
	(mm)	(mm)	(mm)	(mm)	(mm)	(mm)	(°)	(°)					
R	S08K-SEUCR 06	8	11	7	7	3.5	125	-5	0	0.06	G1213	SE23	SE24
	S10M-SEUCR 06	10	13	8	9	4.5	150	-5	0	0.10	G1213	SE23	SE24
	S12M-SEUCR 08	12	15	9	11	5.5	150	-5	0	0.14	G1210	SE24	SE24
	S16R-SEUCR 08	16	20	11	15	7.5	200	-5	0	0.32	G1210	SE24	SE24
	S20S-SEUCR 08	20	25	13	18	9	250	-5	0	0.58	G1210	SE24	SE24
	S25T-SEUCR 08	25	32	17	23	11.5	300	-4	0	1.06	G1210	SE24	SE24
L	S08K-SEUCL 06	8	11	7	7	3.5	125	-5	0	0.06	G1213	SE23	SE24
	S10M-SEUCL 06	10	13	8	9	4.5	150	-5	0	0.10	G1213	SE23	SE24
	S12M-SEUCL 08	12	15	9	11	5.5	150	-5	0	0.14	G1210	SE24	SE24
	S16R-SEUCL 08	16	20	11	15	7.5	200	-5	0	0.32	G1210	SE24	SE24
	S20S-SEUCL 08	20	25	13	18	9	250	-5	0	0.58	G1210	SE24	SE24
	S25T-SEUCL 08	25	32	17	23	11.5	300	-4	0	1.06	G1210	SE24	SE24



G1210
G1213

EC.. 0803..
EC.. 0602..



SE23
SE24

5513 020-03
416.1-832

0.8
3.6

M 2.5
M 3

6.5
8.5

PT-8001
PT-8003



EP

05

KARBÜR UÇLAR

EPGX



110

EPMT



110

DOĞRU BOYUTLA EŞLEŞTİRİN (örnek)

Kesici uç

Takım Tutucu

EPGX 050202FR-JZ

S0608H-SELPR 05

ISO TORNALAMA - İÇ

SELP(RL) INT

95°

EP..



05

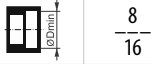
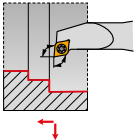

111

110

SELP(RL)-E INT

95°

EP..



05

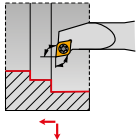

112

110

SEUP(RL) INT

93°

EP..



05

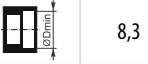
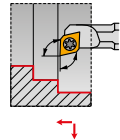

113

110

SEXP(RL) INT

52°30'

EP..



05

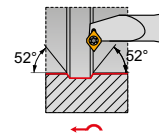

114

110

SEXP(RL)-E INT

52°30'

EP..



05

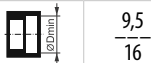
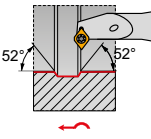

115

110



EPGX



	IC	D1	L	S
	(mm)	(mm)	(mm)	(mm)
0502	5.560	2.50	5.70	2.38

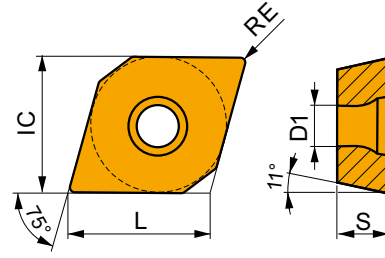

Kesme hızı (vc), ilerleme (f) ve kesme derinliği (ap) için uygunluk ve başlangıç değerleri. Daha ileri hesaplamalar için İşleme Hesaplayıcısı uygulamasına başvurun.

Product	RE	P			M			K			N			S			H		
		vc	f	ap	vc	f	ap	vc	f	ap	vc	f	ap	vc	f	ap	vc	f	ap
	(mm)	(m/min)	(mm/rev)	(mm)	(m/min)	(mm/rev)	(mm)	(m/min)	(mm/rev)	(mm)	(m/min)	(mm/rev)	(mm)	(m/min)	(mm/rev)	(mm)	(m/min)	(mm/rev)	(mm)

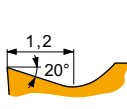

FR-JR sağ kesme yönlü geometri, ince finiş işleme için çok pozitif tasarım, darbesiz kesime uygun.

EPGX 050202FR-JZ	TT010	0.2	295	0.06	0.5	175	0.05	0.5	-	-	-	-	-	-	-	-	-	-	-
-------------------------	--------------	-----	-----	------	-----	-----	------	-----	---	---	---	---	---	---	---	---	---	---	---

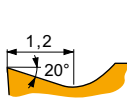

FL-JR sol kesme yönlü geometri, ince finiş işleme için çok pozitif tasarım, darbesiz kesime uygun.

EPGX 050202FL-JZ	TT010	0.2	295	0.06	0.5	175	0.05	0.5	-	-	-	-	-	-	-	-	-	-	-
-------------------------	--------------	-----	-----	------	-----	-----	------	-----	---	---	---	---	---	---	---	---	---	---	---

EPMT



	IC	D1	L	S
	(mm)	(mm)	(mm)	(mm)
0502	5.560	2.50	5.70	2.38

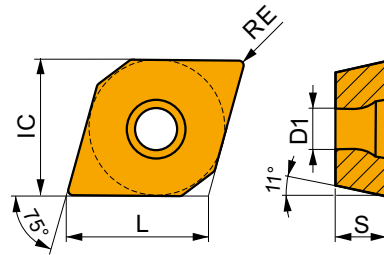

Kesme hızı (vc), ilerleme (f) ve kesme derinliği (ap) için uygunluk ve başlangıç değerleri. Daha ileri hesaplamalar için İşleme Hesaplayıcısı uygulamasına başvurun.

Product	RE	P			M			K			N			S			H		
		vc	f	ap	vc	f	ap	vc	f	ap	vc	f	ap	vc	f	ap	vc	f	ap
	(mm)	(m/min)	(mm/rev)	(mm)	(m/min)	(mm/rev)	(mm)	(m/min)	(mm/rev)	(mm)	(m/min)	(mm/rev)	(mm)	(m/min)	(mm/rev)	(mm)	(m/min)	(mm/rev)	(mm)

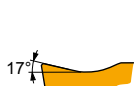

NF1 geometri, ince finişten yarı kabaya kadar işlemek için pozitif tasarım, darbesiz kesim için uygun.

EPMT 050202E-NF2	H07	0.2	-	-	-	80	0.09	0.8	125	0.10	0.8	405	0.12	0.8	40	0.07	0.6	-	-	-
	T7325	0.2	215	0.07	0.8	165	0.06	0.8	-	-	-	-	-	-	65	0.06	0.6	-	-	-
	T7335	0.2	220	0.07	0.8	170	0.06	0.8	-	-	-	-	-	-	70	0.06	0.6	-	-	-
	T9315	0.2	390	0.05	0.8	-	-	-	370	0.05	0.8	-	-	-	-	-	-	-	-	-
	T9325	0.2	305	0.07	0.8	180	0.06	0.8	285	0.07	0.8	-	-	-	65	0.06	0.6	-	-	-
	T9335	0.2	200	0.10	0.8	120	0.09	0.8	-	-	-	-	-	-	45	0.07	0.6	-	-	-
	TT010	0.2	345	0.05	0.5	205	0.05	0.5	-	-	-	-	-	-	-	-	-	-	-	-



SELP(RL) INT



PRAMET

S

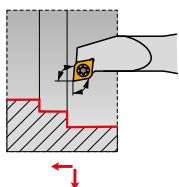

EP.. Uç için Vida Sıkmalı 95° Açılı Delik Kateri

Vida sıkmalı Sağ/Sol 95° içten su vermeli delik kateri. Pozitif EP.. 0502 uçlarla minimum Ø20mm çap, konik ve pah tornalama için uygundur. Ø8-16mm shaft ölçülerinde bulunur. Gövde uzun takım ömrü için işlem görmüştür.

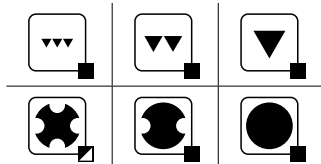
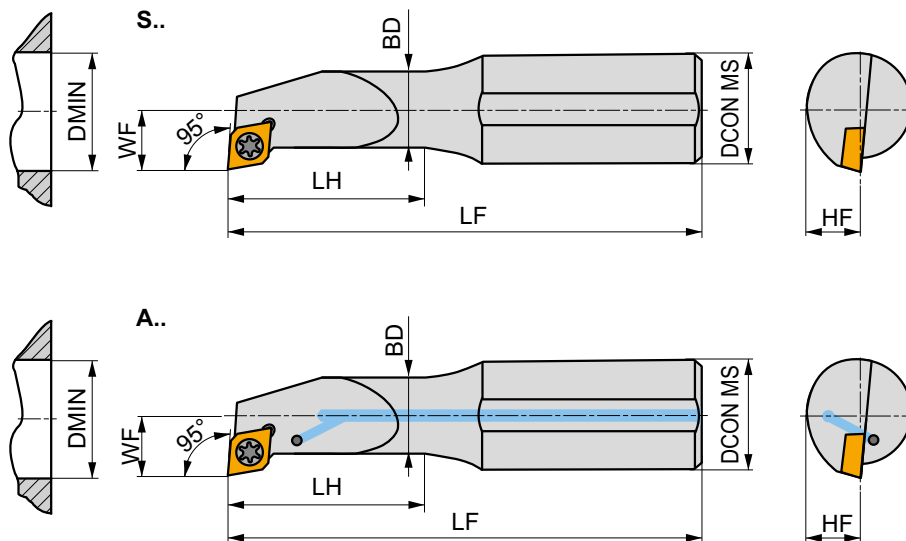

Product	DCON MS	DMIN	BD	WF	LF	LH	LAMS	GAMO				
	(mm)	(mm)	(mm)	(mm)	(mm)	(mm)	(°)	(°)				
R S0608H-SELPR 05	8	8	6	4.5	100	20	-10	0	–	0.04	GI212	SE21
S0810J-SELPR 05	10	11	8	6	110	26	-5	0	–	0.06	GI212	SE22
S1012K-SELPR 05	12	13	10	7	125	32	-5	0	–	0.11	GI212	SE22
A1216M-SELPR 05	16	16	12	9	150	40	-2	0	✓	0.18	GI212	SE22
S1216M-SELPR 05	16	16	12	9	150	40	-2	0	–	0.21	GI212	SE22
L S0608H-SELPL 05	8	8	6	4.5	100	20	-10	0	–	0.04	GI212	SE21
S0810J-SELPL 05	10	11	8	6	110	26	-5	0	–	0.06	GI212	SE22
S1012K-SELPL 05	12	13	10	7	125	32	-5	0	–	0.11	GI212	SE22
S1216M-SELPL 05	16	16	12	9	150	40	-2	0	–	0.21	GI212	SE22



GI212



EP.. 0502..



SE21



28992



0.8



M 2.2



4.2



MA2-8304

SE22

28588

0.8

M 2.2

5.6

MA2-8304



SELP(RL)-E INT



PRAMET

S



EP.. Uç için Vida Sıkmalı 95° Açılı Karbür Delik Kateri

Vida sıkmalı Sağ/Sol 95° içten su vermeli karbür delik kateri. Pozitif EP.. 0502 uçlarla minimum Ø20mm çap, konik ve pah tormalama için uygundur. Ø8-16mm shaft ölçülerinde bulunur. Gövde uzun takım ömrü için işlem görmüştür. Delik boyu > 3xD

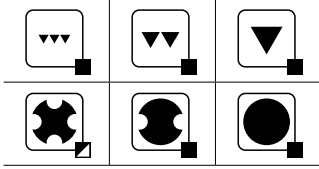
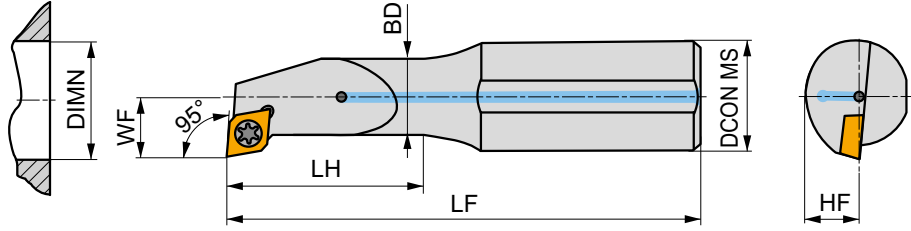
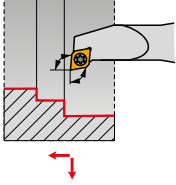

Product	DCON MS (mm)	DMIN (mm)	BD (mm)	WF (mm)	LF (mm)	LH (mm)	LAMS (°)	GAMO (°)		kg		
R E0608H-SELPR 05	8	8	6	4.5	100	28	-10	0	✓	0.06	GI212	SE22
E0810J-SELPR 05	10	11	8	6	110	36	-5	0	✓	0.10	GI212	SE22
E1012K-SELPR 05	12	13	10	7	125	44	-5	0	✓	0.18	GI212	SE22
L E0608H-SELPL 05	8	8	6	4.5	100	28	-10	0	✓	0.06	GI212	SE22
E0810J-SELPL 05	10	11	8	6	110	36	-5	0	✓	0.10	GI212	SE22
E1216M-SELPL 05	16	16	12	9	150	55	-2	0	✓	0.33	GI212	SE22



GI212



EP.. 0502..



SE22



28588



0.8



M 2.2



5.6



MA2-8304



SEUP(RL) INT



PRAMET

S



EP.. Uç için Vida Sıkmalı 93° Açılı Delik Kateri

Vida sıkmalı Sağ/Sol 93° delik kateri. Pozitif EP.. 0502 uçlarla minimum Ø8.3mm çap, konik, ve pah tornalama için uygundur. Ø6mm şaft ölçülerinde bulunur. Gövde uzun takım ömrü için işlem görmüştür.

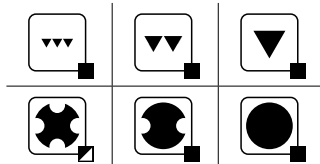
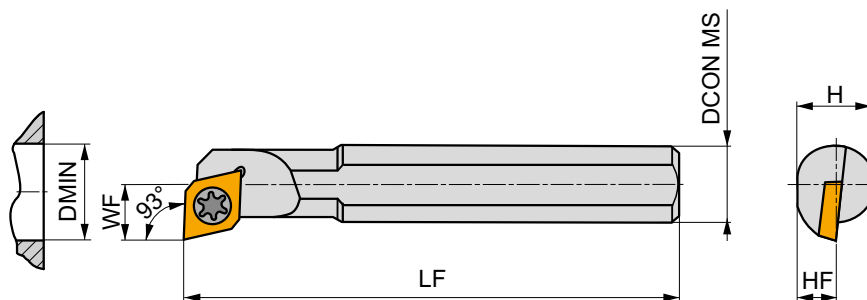
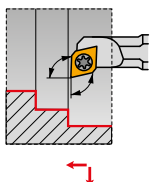

Product	DCON MS (mm)	DMIN (mm)	WF (mm)	H (mm)	HF (mm)	LF (mm)	LAMS (°)	GAMO (°)	kg	GI212	SE21
R S06H-SEUPR 05	6	8.3	5	5.4	2.7	100	-7	0	0.03	GI212	SE21
L S06H-SEUPL 05	6	8.3	5	5.4	2.7	100	-7	0	0.03	GI212	SE21



GI212



EP.. 0502..



SE21



28992



0.8



M 2.2



4.2



MA2-8304



SEXP(RL) INT

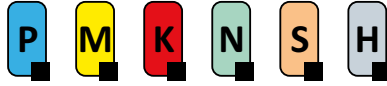

PRAMET

S



EP. Uç için Vida Sıkmalı 52.5° Açılı Delik Kateri

Vida sıkımalı Sağ/Sol 52.5° delik kateri. Pozitif EP.. 0502 uçlarla minimum Ø9.5mm çap, çok yönlü, ters pah, konik, ve pah tormalama için uygundur. Ø8-16mm shaft ölçülerinde bulunur. Gövde uzun takım ömrü için işlem görmüştür.

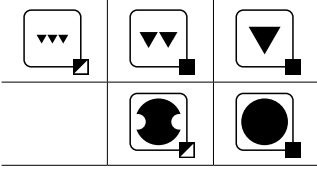
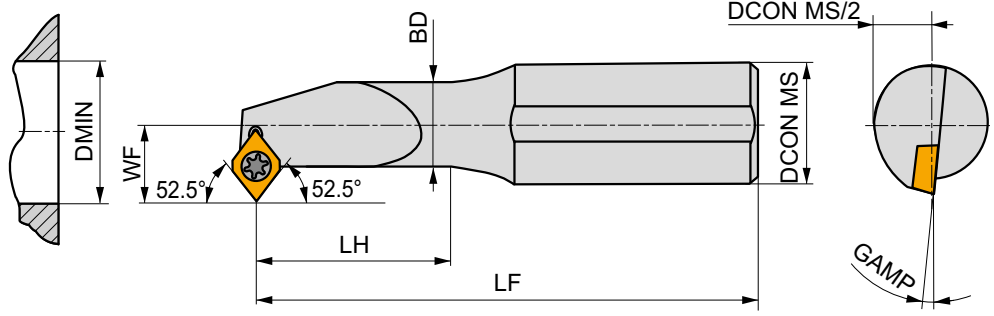
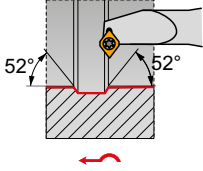

Product	DCON MS (mm)	DMIN (mm)	BD (mm)	WF (mm)	LF (mm)	LH (mm)	GAMP (°)	kg	GI212	SE21/SE22
R S0608H-SEXPR 05	8	9.5	6	5.5	100	20	-7	0.04	GI212	SE21
S0810J-SEXPR 05	10	11	8	6	110	26	-5	0.06	GI212	SE22
S1012K-SEXPR 05	12	13	10	7	125	32	-5	0.11	GI212	SE22
S1216M-SEXPR 05	16	16	12	9	150	40	-2	0.21	GI212	SE22
L S0608H-SEXPL 05	8	9.5	6	5.5	100	20	-7	0.04	GI212	SE21
S0810J-SEXPL 05	10	11	8	6	110	26	-5	0.07	GI212	SE22
S1012K-SEXPL 05	12	13	10	7	125	32	-5	0.11	GI212	SE22
S1216M-SEXPL 05	16	16	12	9	150	40	-2	0.21	GI212	SE22



GI212



EP. 0502..



SE21



28992



0.8



M 2.2



4.2



MA2-8304

SE22

28588

0.8

M 2.2

5.6

MA2-8304



SEXP(RL)-E INT



PRAMET

S



EP.. Uç için Vida Sıkmalı 52.5° Açılı Karbür Delik Kateri

Vida sıkmalı Sağ/Sol 52.5° ,çten su vermeli karbür delik kateri. Pozitif EP.. 0502 uçlarla minimum Ø9.5mm çap, çok yönlü, ters pah, konik, ve pah tornalama için uygundur. Ø8-16mm shaft ölçülerinde bulunur. Gövde uzun takım ömrü için işlem görmüştür. Delik boyu > 3xD

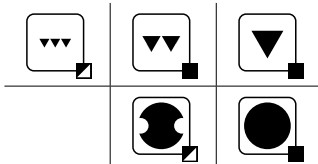
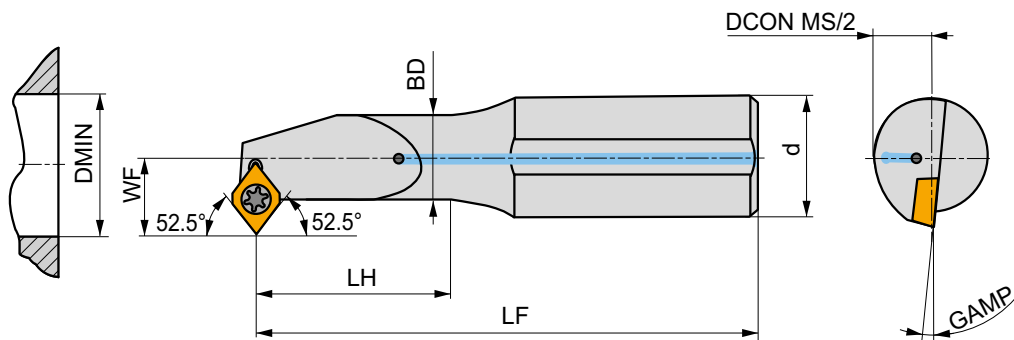
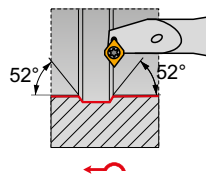

Product	DCON MS (mm)	DMIN (mm)	BD (mm)	WF (mm)	LF (mm)	LH (mm)	GAMP (°)		kg		
R E0608H-SEXPR 05	8	9.5	6	5.5	100	28	-7	✓	0.07	GI212	SE21
E0810J-SEXPR 05	10	11	8	6	110	36	-5	✓	0.11	GI212	SE22
E1012K-SEXPR 05	12	13	10	7	125	44	-5	✓	0.16	GI212	SE22
E1216M-SEXPR 05	16	16	12	9	150	55	-2	✓	0.32	GI212	SE22
L E0608H-SEXPL 05	8	9.5	6	5.5	100	28	-7	✓	0.06	GI212	SE21



GI212



EP..0502..



SE21



28992



0.8



M 2.2



4.2



MA2-8304

SE22

28588

0.8

M 2.2

5.6

MA2-8304



RC

06/ 08/ 12/ 16/ 20/ 25/ 32

KARBÜR UÇLAR

RCGT	RCMT	RCMW	RCMX
118	118	120	121

CER UÇLAR

RCGX CER
123

DOĞRU BOYUTLA EŞLEŞTİRİN (örnek)

Kesici uç	Takım Tutucu
RCMT 1204MOE-RM3	SRDCN 3225 P 12-M

ISO TORNALAMA - DIŞ

PRDCN EXT	PRSC(RL) EXT	SRDC(RL) EXT	SRDCN EXT
RC.. 20 25 32	RC.. 16 25	RC.. 08	RC.. 06 08 10 12 16
40x40 50x50	40x40	20x20 32x25	12x12 32x25
124 118 - 123	125 118 - 123	126 118 - 123	127 118 - 123
SRSC(RL) EXT	C.-SRDCN EXT NEW		
RC.. 06 08 10 12 16	RC.. 10 12		
12x12 32x25	C4 C5		
128 118 - 123	130 118 - 123		



RC

06/ 08/ 12/ 16/ 20/ 25/ 32

ISO TORNALAMA - AĞIR KABA - DIŞ

KHP-RSCR/L + DKH(RL)

<p>DKHR+KHP-RSCR</p>		RC..
		<p>20 25 32</p>
	<p>40×50 60×80</p>	
<p>131, 132</p>	<p>118 – 123</p>	



RCGT

PRAMET

	INSD	D1	S
	(mm)	(mm)	(mm)
0803	8.0	3.40	3.18
1003	10.0	4.40	3.18

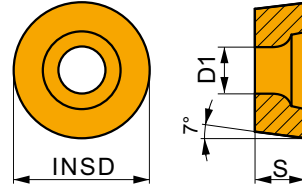

Kesme hızı (vc), ilerleme (f) ve kesme derinliği (ap) için uygunluk ve başlangıç değerleri. Daha ileri hesaplamalar için İşleme Hesaplayıcısı uygulamasına başvurun.

Product	RE	P			M			K			N			S			H		
		vc	f	ap	vc	f	ap	vc	f	ap	vc	f	ap	vc	f	ap	vc	f	ap
	(mm)	(m/min)	(mm/rev)	(mm)	(m/min)	(mm/rev)	(mm)	(m/min)	(mm/rev)	(mm)	(m/min)	(mm/rev)	(mm)	(m/min)	(mm/rev)	(mm)	(m/min)	(mm/rev)	(mm)

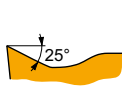

AL geometri, ince finişten kabaya, ve darbesizden hafif darbeli kesmeye kadar uygun, çok pozitif tasarım.

RCGT 0803MOF-AL	HF7	-	-	-	-	-	-	-	-	285	1.20	1.0	-	-	-	-	-	-
	T0315	-	-	-	-	-	-	-	-	420	1.20	1.0	-	-	-	-	-	-
RCGT 1003MOF-AL	HF7	-	-	-	-	-	-	-	-	255	1.50	1.0	-	-	-	-	-	-
	T0315	-	-	-	-	-	-	-	-	390	1.50	1.0	-	-	-	-	-	-

RCMT

PRAMET

	INSD	D1	S
	(mm)	(mm)	(mm)
0602	6.0	2.80	2.38
0803	8.0	3.40	3.18
10T3	10.0	4.40	3.97
1204	12.0	4.40	4.76
1606	16.0	5.50	6.35
2006	20.0	6.50	6.35
2507	25.0	8.60	7.94

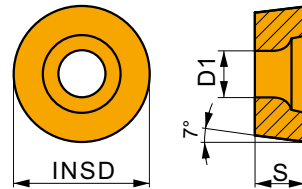

Kesme hızı (vc), ilerleme (f) ve kesme derinliği (ap) için uygunluk ve başlangıç değerleri. Daha ileri hesaplamalar için İşleme Hesaplayıcısı uygulamasına başvurun.

Product	RE	P			M			K			N			S			H		
		vc	f	ap	vc	f	ap	vc	f	ap	vc	f	ap	vc	f	ap	vc	f	ap
	(mm)	(m/min)	(mm/rev)	(mm)	(m/min)	(mm/rev)	(mm)	(m/min)	(mm/rev)	(mm)	(m/min)	(mm/rev)	(mm)	(m/min)	(mm/rev)	(mm)	(m/min)	(mm/rev)	(mm)

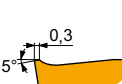

Geometri 37, yarı kabadan ağır kaba işleme kadar, ve darbesizden darbeli kesime kadar uygun.

RCMT 1606MOS-37	T9315	-	165	0.60	3.0	-	-	-	155	0.60	3.0	-	-	-	-	-	-	-
	T9325	-	145	0.60	3.0	-	-	-	135	0.60	3.0	-	-	-	-	-	-	-

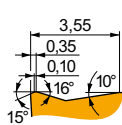

Geometri 371, yarı kabadan ağır kaba işleme kadar, ve darbesizden darbeli kesime kadar uygun.

RCMT 2006MOS-371	T9315	-	145	0.80	3.0	-	-	-	135	0.80	3.0	-	-	-	-	-	-	-
	T9325	-	125	0.80	3.0	-	-	-	115	0.80	3.0	-	-	-	-	-	-	-



Kesme hızı (vc), ilerleme (f) ve kesme derinliği (ap) için uygunluk ve başlangıç değerleri. Daha ileri hesaplamalar için İşleme Hesaplayıcısı uygulamasına başvurun.

Product	RE (mm)	P			M			K			N			S			H		
		vc (m/min)	f (mm/rev)	ap (mm)	vc (m/min)	f (mm/rev)	ap (mm)	vc (m/min)	f (mm/rev)	ap (mm)	vc (m/min)	f (mm/rev)	ap (mm)	vc (m/min)	f (mm/rev)	ap (mm)	vc (m/min)	f (mm/rev)	ap (mm)

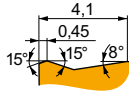

Geometri 372, yarı kabadan ağır kaba işlemeye kadar, ve darbesizden darbeli kesime kadar uygun.

RCMT 2507M05-372	T9325	-	90	0.80	3.0	-	-	-	85	0.80	3.0	-	-	-	-	-	-	-	-
------------------	-------	---	----	------	-----	---	---	---	----	------	-----	---	---	---	---	---	---	---	---

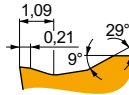

FM geometri, finiştan yarı kaba işlemeye, ve darbesizden hafif darbeli kesmeye kadar uygun.

RCMT 0602M0E-FM	T7325	-	215	0.45	1.2	165	0.41	1.2	-	-	-	-	-	-	-	-	-	-	-	
	T8330	-	190	0.45	1.2	110	0.41	1.2	180	0.45	1.2	570	0.54	1.2	-	-	-	-	-	
	T8430	-	200	0.45	1.2	110	0.41	1.2	165	0.45	1.2	555	0.54	1.2	-	-	-	-	-	
	T9315	-	260	0.45	1.2	-	-	-	245	0.45	1.2	-	-	-	-	-	-	-	-	-
	T9325	-	235	0.45	1.2	140	0.41	1.2	220	0.45	1.2	-	-	-	-	-	-	-	-	-
RCMT 0803M0E-FM	T7325	-	190	0.60	1.6	145	0.54	1.6	-	-	-	-	-	-	-	-	-	-	-	
	T8330	-	170	0.60	1.6	100	0.54	1.6	160	0.60	1.6	510	0.72	1.6	-	-	-	-	-	
	T8430	-	175	0.60	1.6	95	0.54	1.6	140	0.60	1.6	480	0.72	1.6	-	-	-	-	-	
	T9315	-	225	0.60	1.6	-	-	-	210	0.60	1.6	-	-	-	-	-	-	-	-	-
	T9325	-	200	0.60	1.6	120	0.54	1.6	190	0.60	1.6	-	-	-	-	-	-	-	-	-
RCMT 10T3M0E-FM	T7325	-	185	0.65	1.7	140	0.59	1.7	-	-	-	-	-	-	-	-	-	-	-	
	T8330	-	165	0.65	1.7	95	0.59	1.7	155	0.65	1.7	495	0.78	1.7	-	-	-	-	-	
	T8430	-	170	0.65	1.7	90	0.59	1.7	135	0.65	1.7	465	0.78	1.7	-	-	-	-	-	
	T9315	-	220	0.65	1.7	-	-	-	205	0.65	1.7	-	-	-	-	-	-	-	-	-
	T9325	-	195	0.65	1.7	115	0.59	1.7	185	0.65	1.7	-	-	-	-	-	-	-	-	-
RCMT 1204M0E-FM	T7325	-	175	0.70	1.8	135	0.63	1.8	-	-	-	-	-	-	-	-	-	-	-	
	T8330	-	160	0.70	1.8	95	0.63	1.8	150	0.70	1.8	480	0.84	1.8	-	-	-	-	-	
	T8430	-	155	0.70	1.8	85	0.63	1.8	130	0.70	1.8	435	0.84	1.8	-	-	-	-	-	
	T9315	-	205	0.70	1.8	-	-	-	190	0.70	1.8	-	-	-	-	-	-	-	-	-
	T9325	-	190	0.70	1.8	110	0.63	1.8	180	0.70	1.8	-	-	-	-	-	-	-	-	-

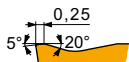

RM3 geometri, yarı kabadan kaba işlemeye kadar, ve darbesizden darbeli kesime kadar uygun.

RCMT 0803M0E-RM3	T7325	-	185	0.50	1.3	140	0.45	1.3	-	-	-	-	-	-	-	-	-	-	-	
	T9315	-	225	0.50	1.3	-	-	-	210	0.50	1.3	-	-	-	-	-	-	45	0.15	1.0
RCMT 1204M0E-RM3	H07	-	-	-	-	65	0.54	1.8	105	0.60	1.8	-	-	-	-	-	-	-	-	
	T7325	-	165	0.60	1.8	125	0.54	1.8	-	-	-	-	-	-	-	-	-	-	-	
	T8330	-	150	0.60	1.8	90	0.54	1.8	140	0.60	1.8	-	-	-	-	-	-	30	0.15	1.0
	T8430	-	150	0.60	1.8	80	0.54	1.8	125	0.60	1.8	-	-	-	-	-	-	25	0.15	1.0
	T9315	-	205	0.60	1.8	-	-	-	190	0.60	1.8	-	-	-	-	-	-	40	0.15	1.0
RCMT 1606M0E-RM3	T7325	-	160	0.65	2.0	120	0.59	2.0	-	-	-	-	-	-	-	-	-	-	-	
	T8330	-	145	0.65	2.0	85	0.59	2.0	135	0.65	2.0	-	-	-	-	-	-	25	0.15	1.0
	T8430	-	145	0.65	2.0	80	0.59	2.0	120	0.65	2.0	-	-	-	-	-	-	25	0.15	1.0
	T9315	-	195	0.65	2.0	-	-	-	185	0.65	2.0	-	-	-	-	-	-	35	0.15	1.0
RCMT 2507M0E-RM3	H07	-	-	-	-	60	0.54	3.0	95	0.60	3.0	-	-	-	-	-	-	-	-	

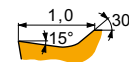

UR geometri, inceden finişe kadar işleme için, ve darbesiz ve hafif darbeli kesim.

RCMT 0602M0E-UR	T6310	-	170	0.40	1.2	120	0.36	1.2	135	0.40	1.2	-	-	-	-	-	-	-	-	
	T7325	-	190	0.40	1.2	145	0.36	1.2	-	-	-	-	-	-	-	-	-	-	-	
	T8330	-	170	0.40	1.2	100	0.36	1.2	160	0.40	1.2	-	-	-	-	-	-	-	-	
	T8430	-	180	0.40	1.2	95	0.36	1.2	145	0.40	1.2	-	-	-	-	-	-	-	-	
	T9315	-	240	0.40	1.2	-	-	-	225	0.40	1.2	-	-	-	-	-	-	-	-	-
	T9325	-	215	0.40	1.2	125	0.36	1.2	200	0.40	1.2	-	-	-	-	-	-	-	-	-



Kesme hızı (vc), ilerleme (f) ve kesme derinliği (ap) için uygunluk ve başlangıç değerleri. Daha ileri hesaplamalar için İşleme Hesaplayıcısı uygulamasına başvurun.

Product	RE (mm)	P			M			K			N			S			H				
		vc (m/min)	f (mm/rev)	ap (mm)	vc (m/min)	f (mm/rev)	ap (mm)	vc (m/min)	f (mm/rev)	ap (mm)	vc (m/min)	f (mm/rev)	ap (mm)	vc (m/min)	f (mm/rev)	ap (mm)	vc (m/min)	f (mm/rev)	ap (mm)		
	1.0 15° 30°																				
		UR geometri, inceden finişe kadar işleme için, ve darbesiz ve hafif darbeli kesim.																			
		T6310	—	■	160	0.45	1.6	✓	115	0.41	1.6	■	125	0.45	1.6	—	—	—	—	—	—
		T7325	—	■	180	0.45	1.6	✓	140	0.41	1.6	—	—	—	—	—	—	—	—	—	—
		T8330	—	■	160	0.45	1.6	✓	95	0.41	1.6	■	150	0.45	1.6	—	—	—	—	—	—
		T8430	—	■	170	0.45	1.6	✓	90	0.41	1.6	✓	135	0.45	1.6	—	—	—	—	—	—
RCMT 10T3MOE-UR	T9315	—	■	220	0.45	1.6	—	—	—	✓	205	0.45	1.6	—	—	—	—	—	—		
	T9325	—	■	200	0.45	1.6	✓	120	0.41	1.6	✓	190	0.45	1.6	—	—	—	—	—		
	T6310	—	■	160	0.50	1.4	✓	115	0.45	1.4	■	125	0.50	1.4	—	—	—	—	—		
	T7325	—	■	175	0.50	1.4	✓	135	0.45	1.4	—	—	—	—	—	—	—	—	—		
	T8330	—	■	160	0.50	1.4	✓	95	0.45	1.4	■	150	0.50	1.4	—	—	—	—	—		
	T8430	—	■	165	0.50	1.4	✓	90	0.45	1.4	✓	135	0.50	1.4	—	—	—	—	—		
RCMT 1204MOE-UR	T9315	—	■	215	0.50	1.4	—	—	—	✓	200	0.50	1.4	—	—	—	—	—	—		
	T9325	—	■	190	0.50	1.4	✓	110	0.45	1.4	✓	180	0.50	1.4	—	—	—	—	—		
	T6310	—	■	150	0.55	1.8	✓	105	0.50	1.8	■	120	0.55	1.8	—	—	—	—	—		
	T7325	—	■	165	0.55	1.8	✓	125	0.50	1.8	—	—	—	—	—	—	—	—	—		
	T8330	—	■	150	0.55	1.8	✓	90	0.50	1.8	■	140	0.55	1.8	—	—	—	—	—		
	T8430	—	■	145	0.55	1.8	✓	80	0.50	1.8	✓	120	0.55	1.8	—	—	—	—	—		
T9315	—	■	200	0.55	1.8	—	—	—	—	✓	190	0.55	1.8	—	—	—	—	—	—		
T9325	—	■	180	0.55	1.8	✓	105	0.50	1.8	✓	170	0.55	1.8	—	—	—	—	—	—		

RCMW



	INSD (mm)	D1 (mm)	S (mm)
0602	6.0	2.80	2.38
0803	8.0	3.40	3.18
10T3	10.0	4.40	3.97
1204	12.0	4.40	4.76

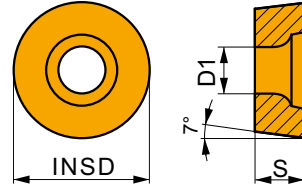

Kesme hızı (vc), ilerleme (f) ve kesme derinliği (ap) için uygunluk ve başlangıç değerleri. Daha ileri hesaplamalar için İşleme Hesaplayıcısı uygulamasına başvurun.

Product	RE (mm)	P			M			K			N			S			H						
		vc (m/min)	f (mm/rev)	ap (mm)	vc (m/min)	f (mm/rev)	ap (mm)	vc (m/min)	f (mm/rev)	ap (mm)	vc (m/min)	f (mm/rev)	ap (mm)	vc (m/min)	f (mm/rev)	ap (mm)	vc (m/min)	f (mm/rev)	ap (mm)				
	1.0 15° 30°																						
		İnce finişten yarı kaba işleme kadar ve darbesizden hafif darbeli kesmeye kadar uygun.																					
RCMW 0602MO	T5305	—	—	—	—	—	—	—	—	■	280	0.25	0.6	—	—	—	—	—	—	✓	55	0.15	1.0
	T5315	—	—	—	—	—	—	—	—	■	250	0.25	0.6	—	—	—	—	—	—	✓	50	0.15	1.0
RCMW 0803MO	T5305	—	—	—	—	—	—	—	—	■	255	0.30	0.8	—	—	—	—	—	—	✓	50	0.15	1.0
	T5315	—	—	—	—	—	—	—	—	■	230	0.30	0.8	—	—	—	—	—	—	✓	45	0.15	1.0
RCMW 10T3MO	T5305	—	—	—	—	—	—	—	—	■	225	0.40	1.0	—	—	—	—	—	—	✓	45	0.15	1.0
	T5315	—	—	—	—	—	—	—	—	■	200	0.40	1.0	—	—	—	—	—	—	✓	40	0.15	1.0
RCMW 1204MO	T5305	—	—	—	—	—	—	—	—	■	205	0.45	1.2	—	—	—	—	—	—	✓	40	0.15	1.0
	T5315	—	—	—	—	—	—	—	—	■	190	0.45	1.2	—	—	—	—	—	—	✓	40	0.15	1.0



RCMX

	INSD (mm)	D1 (mm)	S (mm)
1003	10.0	3.60	3.18
1204	12.0	4.20	4.76
1606	16.0	5.20	6.35
2006	20.0	6.50	6.35
2507	25.0	7.20	7.94
3209	32.0	9.50	9.53

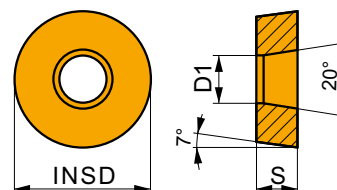

Kesme hızı (vc), ilerleme (f) ve kesme derinliği (ap) için uygunluk ve başlangıç değerleri. Daha ileri hesaplamalar için İşleme Hesaplayıcısı uygulamasına başvurun.

Product	RE (mm)	P			M			K			N			S			H		
		vc (m/min)	f (mm/rev)	ap (mm)	vc (m/min)	f (mm/rev)	ap (mm)	vc (m/min)	f (mm/rev)	ap (mm)	vc (m/min)	f (mm/rev)	ap (mm)	vc (m/min)	f (mm/rev)	ap (mm)	vc (m/min)	f (mm/rev)	ap (mm)

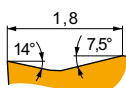

Geometri 31, finiştan yarı kaba işlemeye kadar, ve darbesizden darbeli kesime kadar uygun.

RCMX 1003M05-31

T9325	-	165	0.50	2.0	95	0.45	2.0	155	0.50	2.0	-	-	-	-	-	-	-	-
T9335	-	140	0.50	2.0	80	0.45	2.0	-	-	-	-	-	-	-	-	-	-	-

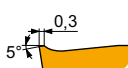

Geometri 37, yarı kabadan ağır kaba işlemeye kadar, ve darbesizden darbeli kesime kadar uygun.

RCMX 1606M05-37

T9315	-	165	0.60	3.0	-	-	-	155	0.60	3.0	-	-	-	-	-	-	-	-
T9325	-	145	0.60	3.0	-	-	-	135	0.60	3.0	-	-	-	-	-	-	-	-

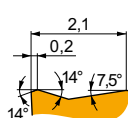

Geometri 321, yarı kabadan ağır kaba işlemeye kadar, ve darbesizden darbeli kesime kadar uygun.

RCMX 1204M05-321

T9315	-	130	1.00	3.0	-	-	-	120	1.00	3.0	-	-	-	-	-	-	-	-
T9325	-	120	1.00	3.0	-	-	-	110	1.00	3.0	-	-	-	-	-	-	-	-
T9335	-	105	1.00	3.0	-	-	-	-	-	-	-	-	-	-	-	-	-	-

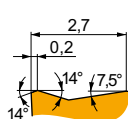

Geometri 331, yarı kabadan ağır kaba işlemeye kadar, ve darbesizden darbeli kesime kadar uygun.

RCMX 1606M05-331

T9315	-	120	1.20	3.5	-	-	-	110	1.20	3.5	-	-	-	-	-	-	-	-
T9325	-	105	1.20	3.5	-	-	-	95	1.20	3.5	-	-	-	-	-	-	-	-
T9335	-	110	0.80	3.5	-	-	-	-	-	-	-	-	-	-	-	-	-	-

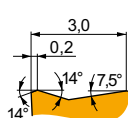

Geometri 341, yarı kabadan ağır kaba işlemeye kadar, ve darbesizden darbeli kesime kadar uygun.

RCMX 2006M05-341

6640	-	90	1.00	3.5	-	-	-	85	1.00	3.5	-	-	-	-	-	-	-	-
------	---	----	------	-----	---	---	---	----	------	-----	---	---	---	---	---	---	---	---

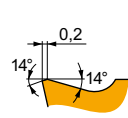

Geometri 351, yarı kabadan ağır kaba işlemeye kadar, ve darbesizden darbeli kesime kadar uygun.

RCMX 2507M05-351

6640	-	60	1.00	3.5	-	-	-	55	1.00	3.5	-	-	-	-	-	-	-	-
------	---	----	------	-----	---	---	---	----	------	-----	---	---	---	---	---	---	---	---



Kesme hızı (vc), ilerleme (f) ve kesme derinliği (ap) için uygunluk ve başlangıç değerleri. Daha ileri hesaplamalar için İşleme Hesaplayıcısı uygulamasına başvurun.

Product	RE (mm)	P			M			K			N			S			H		
		vc (m/min)	f (mm/rev)	ap (mm)	vc (m/min)	f (mm/rev)	ap (mm)	vc (m/min)	f (mm/rev)	ap (mm)	vc (m/min)	f (mm/rev)	ap (mm)	vc (m/min)	f (mm/rev)	ap (mm)	vc (m/min)	f (mm/rev)	ap (mm)

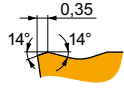

Geometri 361, kabadan ağır kaba işlemeye kadar, ve darbesizden darbeli kesime kadar uygun.

RCMX 3209M0S-361	6640	-	50	1.40	4.5	-	-	-	45	1.40	4.5	-	-	-	-	-	-	-	-
------------------	------	---	----	------	-----	---	---	---	----	------	-----	---	---	---	---	---	---	---	---

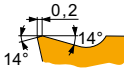

RF1 geometri, finiştan yarı kaba işlemeye kadar, ve darbesizden darbeli kesime kadar uygun.

RCMX 2006M0-RF1	T5305	-	105	0.80	3.5	-	-	-	95	0.80	3.5	-	-	-	-	-	-	-	-
	T9310	-	105	0.80	3.5	-	-	-	95	0.80	3.5	-	-	-	-	-	-	-	-
	T9315	-	100	0.80	3.5	-	-	-	95	0.80	3.5	-	-	-	-	-	-	-	-
	T9325	-	90	0.80	3.5	-	-	-	85	0.80	3.5	-	-	-	-	-	-	-	-
	T9335	-	110	0.80	3.5	-	-	-	-	-	-	-	-	-	-	-	-	-	-
RCMX 2507M0-RF1	T8345	-	45	1.00	3.5	-	-	-	40	1.00	3.5	-	-	-	-	-	-	-	-
	T9310	-	95	1.00	3.5	-	-	-	90	1.00	3.5	-	-	-	-	-	-	-	-
	T9315	-	90	1.00	3.5	-	-	-	85	1.00	3.5	-	-	-	-	-	-	-	-
	T9325	-	80	1.00	3.5	-	-	-	75	1.00	3.5	-	-	-	-	-	-	-	-
	T9335	-	65	1.00	3.5	-	-	-	-	-	-	-	-	-	-	-	-	-	-

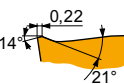

RM1 geometri, finiştan kaba işlemeye kadar, ve darbesizden darbeli kesime kadar uygun.

RCMX 2006M0-RM1	T9310	-	95	1.00	3.5	-	-	-	90	1.00	3.5	-	-	-	-	-	-	-	-
	T9315	-	90	1.00	3.5	-	-	-	85	1.00	3.5	-	-	-	-	-	-	-	-
	T9325	-	80	1.00	3.5	-	-	-	75	1.00	3.5	-	-	-	-	-	-	-	-
	T9335	-	125	0.60	3.0	-	-	-	-	-	-	-	-	-	-	-	-	-	-
RCMX 2507M0-RM1	T9310	-	95	1.00	3.5	-	-	-	90	1.00	3.5	-	-	-	-	-	-	-	-
	T9315	-	90	1.00	3.5	-	-	-	85	1.00	3.5	-	-	-	-	-	-	-	-
	T9325	-	80	1.00	3.5	-	-	-	75	1.00	3.5	-	-	-	-	-	-	-	-
	T9335	-	80	0.60	3.0	-	-	-	-	-	-	-	-	-	-	-	-	-	-

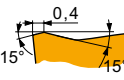

RM2 geometri, yarı kabadan kaba işlemeye kadar, ve darbesizden darbeli kesime kadar uygun.

RCMX 2507M0-RM2	T9310	-	90	1.10	3.5	-	-	-	85	1.10	3.5	-	-	-	-	-	-	-	-
	T9315	-	85	1.10	3.5	-	-	-	80	1.10	3.5	-	-	-	-	-	-	-	-
	T9325	-	75	1.10	3.5	-	-	-	70	1.10	3.5	-	-	-	-	-	-	-	-
RCMX 3209M0-RM2	T5315	-	95	1.00	4.5	-	-	-	90	1.00	4.5	-	-	-	-	-	-	-	-
	T9310	-	90	1.00	4.5	-	-	-	85	1.00	4.5	-	-	-	-	-	-	-	-
	T9315	-	85	1.00	4.5	-	-	-	80	1.00	4.5	-	-	-	-	-	-	-	-
	T9325	-	75	1.00	4.5	-	-	-	70	1.00	4.5	-	-	-	-	-	-	-	-
	T9335	-	55	1.40	4.5	-	-	-	-	-	-	-	-	-	-	-	-	-	-

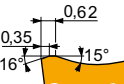

RR geometri, ağır kaba işleme, ve darbesizden darbeli kesime kadar uygun.

RCMX 3209M0-RR2	T9315	-	60	1.40	4.5	-	-	-	55	1.40	4.5	-	-	-	-	-	-	10	0.15	1.0
	T9316	-	60	1.40	4.5	-	-	-	55	1.40	4.5	-	-	-	-	-	-	-	-	-



RCGX CER

	INSD (mm)	S (mm)
0606	6.350	6.35
0907	9.525	7.94
1207	12.700	7.94

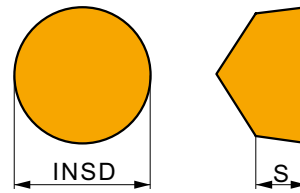

Kesme hızı (vc), ilerleme (f) ve kesme derinliği (ap) için uygunluk ve başlangıç değerleri. Daha ileri hesaplamalar için İşleme Hesaplayıcısı uygulamasına başvurun.

Product	RE (mm)	P			M			K			N			S			H		
		vc (m/min)	f (mm/rev)	ap (mm)	vc (m/min)	f (mm/rev)	ap (mm)	vc (m/min)	f (mm/rev)	ap (mm)	vc (m/min)	f (mm/rev)	ap (mm)	vc (m/min)	f (mm/rev)	ap (mm)			

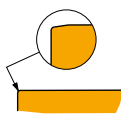

Yüksek hızlı işleme ve darbesiz kesme için.

RCGX 060600 K15015	TC100	-	-	-	-	-	-	-	365	0.30	0.8	-	-	-	-	-	-	-
RCGX 090700 K15015	TC100	-	-	-	-	-	-	-	410	0.20	1.2	-	-	-	-	-	-	-
RCGX 120700 K15015	TC100	-	-	-	-	-	-	-	405	0.20	1.5	-	-	-	-	-	-	-



PRDCN EXT

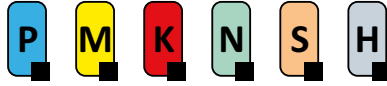

PRAMET

P



RC.. UÇ İÇİN LEVYELİ DIŞ KATER

Levyeli nötr dış kater. RC.. 16-32 uçlarla çap, 90°'ye kadar kopya, konik ve pah tornalama için uygundur. 32x25'ten 50x50mm'ye kadar mevcuttur. Gövde uzun takım ömrü için işlem görmüştür.

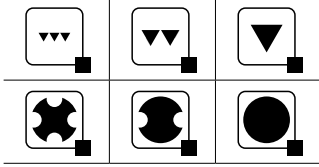
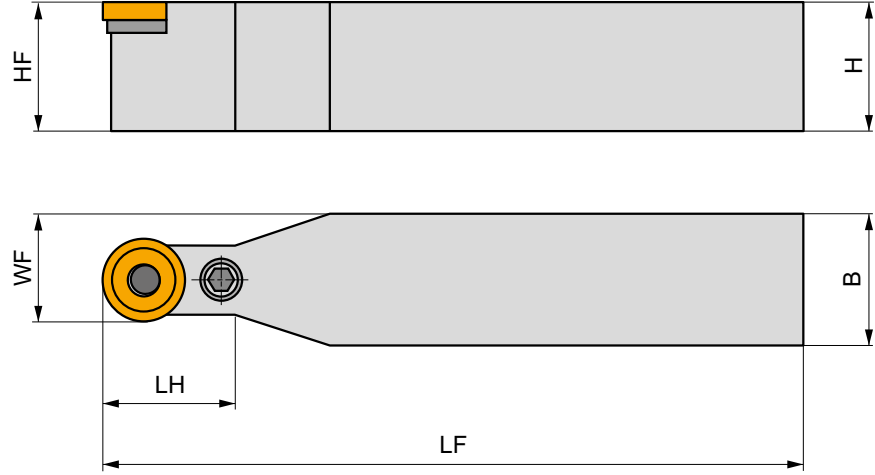
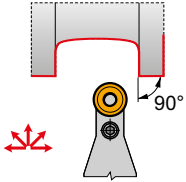

Product	H	B	HF	WF	LF	LH	LAMS	GAMO	kg		
	(mm)	(mm)	(mm)	(mm)	(mm)	(mm)	(°)	(°)			
PRDCN 3225 P 16	32	25	32	20.5	170	32	0	0	0.80	GI090	PRP70
PRDCN 3232 P 20	32	32	32	26	170	32	0	0	1.30	GI069	PRP90
PRDCN 4040 S 20	40	40	40	30	250	40	0	0	3.10	GI069	PRP90
PRDCN 4040 S 25	40	40	40	32.5	250	40	0	0	3.20	GI122	PRP80
PRDCN 5050 S 32	50	50	50	41	250	50	0	0	3.50	GI096	PRP32
PRDCN 5050 T 32	50	50	50	41	300	50	0	0	5.12	GI096	PRP32



GI069
GI090
GI096
GI122

RCMX 2006MO
RCMX 1606MO
RCMX 3209MO
RCMX 2507MO



PRP32
PRP70
PRP80
PRP90

RCU 320600
RCU 160300
RCU 250600
RCU 200400

PU 10
PU 07
PU 08
PU 09

US 47
US 36
US 38
US 36

8.0
6.0
8.0
6.0

M 12x1
M 8x1
M 10x1
M 8x1

36
26
29
26

NT 08
NT 05
NT 06
NT 07

MT 08
MT 05
MT 06
MT 07

HXK 5
HXK 4
HXK 5
HXK 4



PRSC(RL) EXT

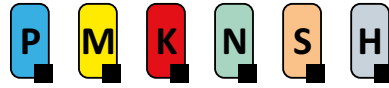

PRAMET

P



RC.. UÇ İÇİN LEVYELİ DİŞ KATER

Levyeli, Sağ/Sol dış kater. Pozitif RC.. 16 - 25 uçlarla çap, 27°'ye kadar kopya, konik ve pah tornalamak için uygundur. 32x25 - 40x40 kadar mevcuttur. Gövde uzun takım ömrü için işlem görmüştür.

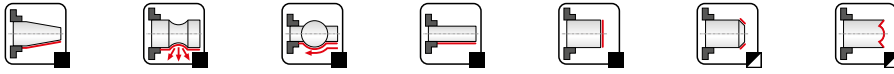
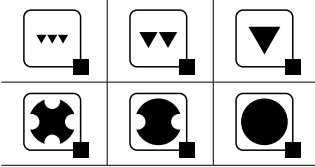
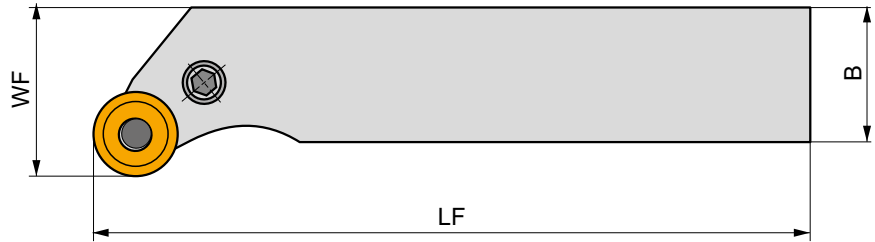
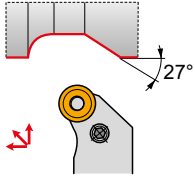

Product	H (mm)	B (mm)	HF (mm)	WF (mm)	LF (mm)	LAMS (°)	GAMO (°)	kg	GI069	GI090	PRP70
R PRSCR 3225 P 16	32	25	32	32	170	0	0	0.90	GI090	PRP70	
PRSCR 4040 R 16	40	40	40	50	200	0	0	2.38	GI090	PRP70	
PRSCR 3232 P 20	32	32	32	40	170	0	0	1.40	GI069	PRP90	
PRSCR 4040 S 25	40	40	40	50	250	0	0	3.40	GI122	PRP80	
L PRSCL 3225 P 16	32	25	32	32	170	0	0	0.90	GI090	PRP70	
PRSCL 4040 R 16	40	40	40	50	200	0	0	2.38	GI090	PRP70	
PRSCL 3232 P 20	32	32	32	40	170	0	0	1.32	GI069	PRP90	
PRSCL 4040 S 25	40	40	40	50	250	0	0	3.40	GI122	PRP80	



GI069
GI090
GI122

RCMX 2006MO
RCMX 1606MO
RCMX 2507MO



PRP70
PRP80
PRP90

RCU 160300
RCU 250600
RCU 200400

PU 07
PU 08
PU 09

US 36
US 38
US 36

6.0
8.0
6.0

M 8x1
M 10x1
M 8x1

26
29
26

NT 05
NT 06
NT 07

MT 05
MT 06
MT 07

HXK 4
HXK 5
HXK 4



SRDC(RL) EXT

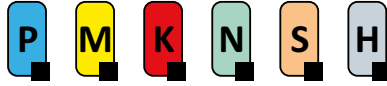

PRAMET

S



RC.. Uç için Vida Sıkmalı Dış Kater

Vida sıkmalı Sağ/Sol dış kater. Pozitif RC.. 08 uçlarla alın, çap, konik ve pah tornalama için uygundur. 20x20-32x25mm şaft ölçülerinde bulunur. Gövde uzun takım ömrü için işlem görmüştür.

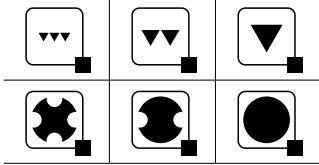
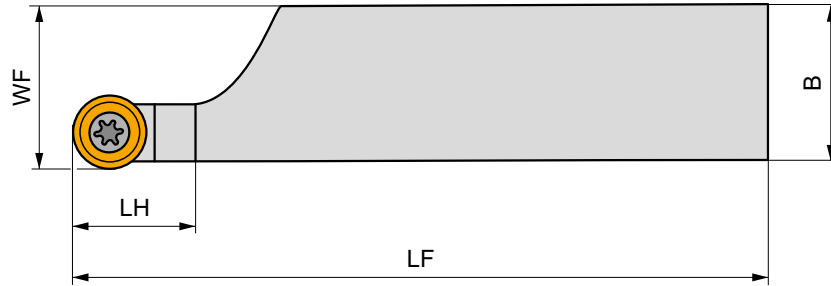
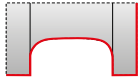

Product	H	B	HF	WF	LF	LH	LAMS	GAMO	kg	GI051	SR21
	(mm)	(mm)	(mm)	(mm)	(mm)	(mm)	(°)	(°)			
R SRDCR 2020 K 08-A	20	20	20	20.5	125	20	0	0	0.36	GI051	SR21
SRDCR 2525 M 08-A	25	25	25	25.5	150	20	0	0	0.66	GI051	SR21
SRDCR 3225 P 08-A	32	25	32	25.5	170	20	0	0	0.95	GI051	SR21
L SRDCL 2020 K 08-A	20	20	20	20.5	125	20	0	0	0.37	GI051	SR21
SRDCL 2525 M 08-A	25	25	25	25.5	150	20	0	0	0.66	GI051	SR21
SRDCL 3225 P 08-A	32	25	32	25.5	170	20	0	0	0.96	GI051	SR21



GI051



RC.. 0803M0



SR21



5513 020-04



1.5



M3



7.2



PT-8002



SRDCN EXT



PRAMET

S



RC.. Uç için Vida Sıklı Dış Kater

Vida sıklı nör dış kater. Pozitif RC.. 06-16 uçlarla çap, alın, kopya, konik ve pah tornalama için uygundur. 12x12-32x25mm mevcuttur. Gövde uzun takım ömrü için işlem görmüştür.

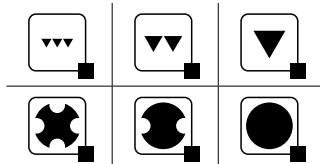
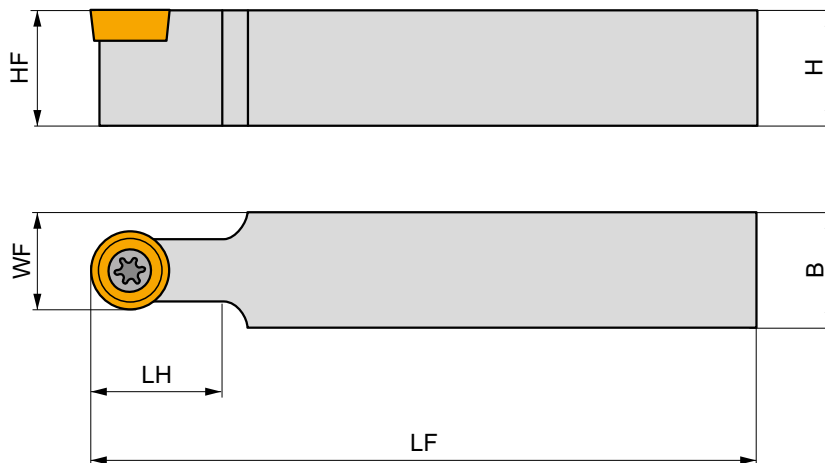
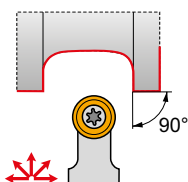

Product	H	B	HF	WF	LF	LH	LAMS	GAMO	kg	GI	SR
	(mm)	(mm)	(mm)	(mm)	(mm)	(mm)	(°)	(°)			
SRDCN 1212 F 06	12	12	12	9	80	12	0	0	0.10	GI054	SO1
SRDCN 1616 H 06	16	16	16	11	100	12	0	0	0.20	GI054	SO1
SRDCN 2020 K 08	20	20	20	14	125	20	0	0	0.38	GI051	SO3
SRDCN 2020 K 1003-M-A	20	20	20	15	125	25	0	0	0.40	GI064	SR10
SRDCN 2020 K 10-M-A	20	20	20	15	125	25	0	0	0.40	GI013	SR10
SRDCN 2525 M 10-M-A	25	25	25	17.5	150	25	0	0	0.68	GI013	SR10
SRDCN 2525 M 12-M-A	25	25	25	18.5	150	30	0	0	0.68	GI014	SR12
SRDCN 3225 P 10-M	32	25	32	17.5	170	25	0	0	0.90	GI013	SR10
SRDCN 3225 P 12-M	32	25	32	18.5	170	30	0	0	0.90	GI014	SR12
SRDCN 3225 P 16-M	32	25	32	20.5	170	32	0	0	1.00	GI161	SR16



GI013	RC.. 10T3MO
GI014	RC.. 1204MO
GI051	RC.. 0803MO
GI054	RC.. 0602MO
GI064	RC.. 1003MO
GI161	RC.. 1606MO



SO1	US 2506-T07P	0.9	M 2.5	6.3	-	-	FLAGT07P	-
SO3	US 3007-T09P	2.0	M 3	7.3	-	-	FLAGT09P	-
SR10	US 3510-T15P	3.0	M 3.5	10.6	SRN 100300	MS 3510	FLAGT15P	HXX 3.5
SR12	US 3510-T15P	3.0	M 3.5	10.6	SRN 120300	MS 3510	FLAGT15P	HXX 3.5
SR16	US 5018-T20P	5.0	M 5	18.2	SRN 16T3MO	MS 5015	FLAGT20P	HXX 5



SRSC(RL) EXT

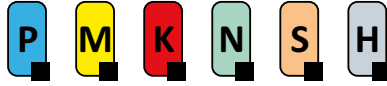

PRAMET

S

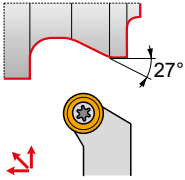

RC.. Uç için Vida Sıkmalı Dış Kater

Vida sıkmalı Sağ/Sol dış kater. Pozitif RC.. 06-16 uçlarla alın, çap, kopya, konik ve pah tornalama için uygundur. 12x12-32x25mm şaft ölçülerinde bulunur. Gövde uzun takım ömrü için işlem görmüştür.

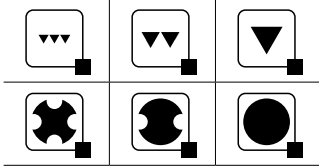
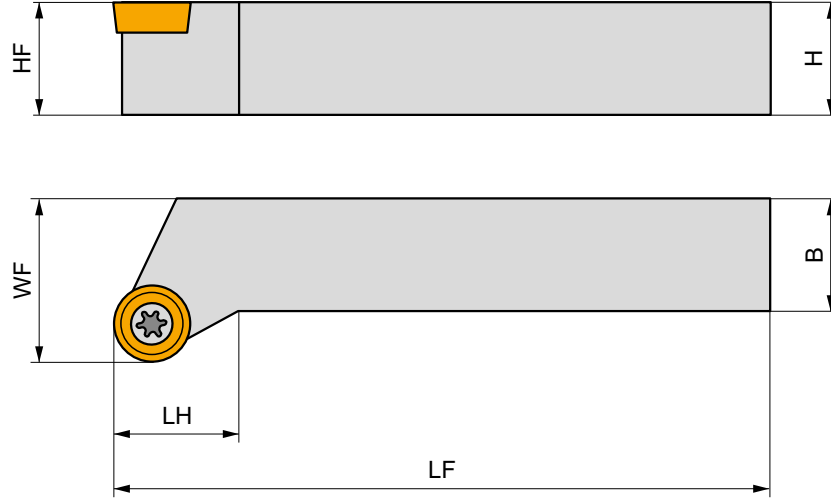









Product	H	B	HF	WF	LF	LH	LAMS	GAMO	kg	GI	SO
	(mm)	(mm)	(mm)	(mm)	(mm)	(mm)	(°)	(°)			
R SRSCR 1212 F 06	12	12	12	16	80	12	0	0	0.09	GI054	SO1
SRSCR 1616 H 06	16	16	16	20	100	12	0	0	0.22	GI054	SO1
SRSCR 2020 K 08	20	20	20	25	125	20	0	0	0.45	GI051	SO3
SRSCR 2020 K 10-M-A	20	20	20	25	125	20	0	0	0.45	GI013	SR10
SRSCR 2525 M 10-M-A	25	25	25	32	150	20	0	0	0.75	GI013	SR10
SRSCR 3225 P 10-M	32	25	32	32	170	20	0	0	1.06	GI013	SR10
SRSCR 2525 M 12-M-A	25	25	25	32	150	20	0	0	0.75	GI014	SR12
SRSCR 3225 P 12-M	32	25	32	32	170	20	0	0	1.07	GI014	SR12
SRSCR 3225 P 16-M	32	25	32	32	170	20	0	0	1.10	GI161	SR16
L SRSCL 1212 F 06	12	12	12	16	80	12	0	0	0.10	GI054	SO1
SRSCL 1616 H 06	16	16	16	20	100	12	0	0	0.22	GI054	SO1
SRSCL 2020 K 08	20	20	20	25	125	20	0	0	0.45	GI051	SO3
SRSCL 2020 K 10-M-A	20	20	20	25	125	20	0	0	0.45	GI013	SR10
SRSCL 2525 M 10-M-A	25	25	25	32	150	20	0	0	0.75	GI013	SR10
SRSCL 3225 P 10-M	32	25	32	32	170	20	0	0	1.06	GI013	SR10
SRSCL 2525 M 12-M-A	25	25	25	32	150	20	0	0	0.75	GI014	SR12
SRSCL 3225 P 12-M	32	25	32	32	170	20	0	0	1.07	GI014	SR12
SRSCL 3225 P 16-M	32	25	32	32	170	20	0	0	1.10	GI161	SR16



GI013	RC.. 10T3MO
GI014	RC.. 1204MO
GI051	RC.. 0803MO
GI054	RC.. 0602MO
GI161	RC.. 1606MO



		 Nm						
S01	US 2506-T07P	0.9	M 2.5	6.3	–	–	FLAG T07P	–
S03	US 3007-T09P	2.0	M 3	7.3	–	–	FLAG T09P	–
SR10	US 3510-T15P	3.0	M 3.5	10.6	SRN 100300	MS 3510	FLAG T15P	HXK 3.5
SR12	US 3510-T15P	3.0	M 3.5	10.6	SRN 120300	MS 3510	FLAG T15P	HXK 3.5
SR16	US 5018-T20P	5.0	M 5	18.2	SRN 16T3MO	MS 5015	FLAG T20P	HXK 5

**NEW****C.-SRDCN EXT**

PRAMET

S**Vida Sıkmalı RC.. Uç için PSC Hızlı Değişirme Dış Kateri**

Vida sıkmalı, içten su vermeli nötr dış kater. Pozitif RC.. 10 veya 12 uçlarla çap, kopya, konik ve pah tornalamak için uygundur. C4'ten C6'ya kadar PSC şaftlı mevcuttur. Tutucu uzun takım ömrü için işlem görmüştür.

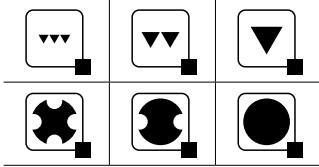
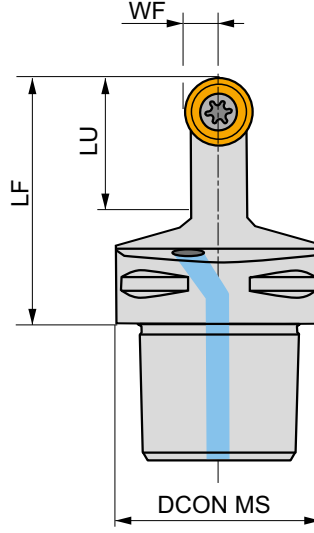
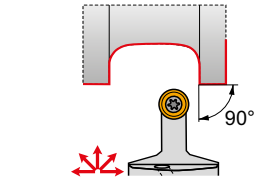

Product	DCON MS (mm)	WF (mm)	LF (mm)	LU (mm)	LAMS (°)	GAMO (°)		kg		
N C4-SRDCN-00050-12A	40	6	50	28	0	0	✓	0.32	GI014	C-SR12V-1
C5-SRDCN-00060-10A	50	5	60	25	0	0	✓	0.56	GI013	C-SR10V
C5-SRDCN-00060-12A	50	6	60	28	0	0	✓	0.56	GI014	C-SR12V-2

GI013	RC.. 10T3M0
GI014	RC.. 1204M0

C-SR10V	US 2010-T15P	3.0	M 3.5	10.1	SRS 110-01	MS 9001	FLAG T15P/3,5	CN 034-02
C-SR12V-1	US 2001-T15P	3.0	M 3.5	12.1	SRS 110-02	MS 9001	FLAG T15P/3,5	CN 034-01
C-SR12V-2	US 2001-T15P	3.0	M 3.5	12.1	SRS 110-02	MS 9001	FLAG T15P/3,5	CN 034-02



KHP-RSC(RL)



PRAMET

P



Modüler KHP LevyeLi Torna Kartuşu, RC.. Uç için

DKH takım tutucu şaft için kırılmaç bağlanırlı Sağ/Sol levyeLi kartuş. Pozitif RC.. 20-32 uçlarla çap, alın, konik ve pah tormalamak için uygundur. Tutucu uzun takım ömrü için işlem görmüştür.

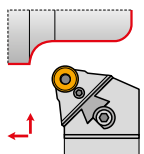

DKHR+KHP-RSCR

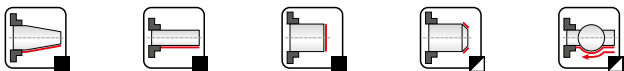
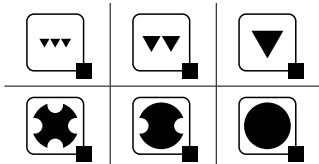
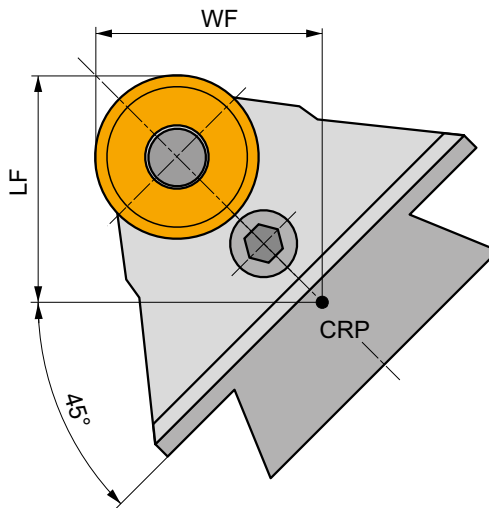

Product	WF	LF	LAMS	GAMO	kg	G1069 G1122 G1096	PRP90 PRP80 PRP32
	(mm)	(mm)	(°)	(°)			
R KHP-RSCR 20	35	45	0	0	1.25	G1069	PRP90
KHP-RSCR 25	35	45	0	0	1.30	G1122	PRP80
KHP-RSCR 32	35	45	0	0	1.30	G1096	PRP32
KHP-RSCL 20	35	45	0	0	1.30	G1069	PRP90
KHP-RSCL 25	35	45	0	0	1.30	G1122	PRP80
KHP-RSCL 32	35	45	0	0	1.30	G1096	PRP32



G1069

RCMX 2006M0

G1096

RCMX 3209M0

G1122

RCMX 2507M0



PRP32

RCU 320600

PU 10

US 47

8.0

M 12x1

36

NT 08

MT 08

HXK 5

PRP80

RCU 250600

PU 08

US 38

8.0

M 10x1

29

NT 06

MT 06

HXK 5

PRP90

RCU 200400

PU 09

US 36

6.0

M 8x1

26

NT 07

MT 07

HXK 4



DKH(RL)

PRAMET



KHP/KHS Ağır Tornalama Kartuşları için Dış Kater Şaftı

KHP/KHS kartuşlar için kırılmalı Sağ/Sol takım şaftı. Ağır tornalama için uygundur. 40x50'den 60x80mm'ye kadar mevcut. Gövde uzun takım ömrü için işlem görmüştür.

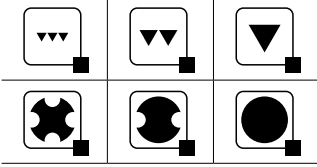
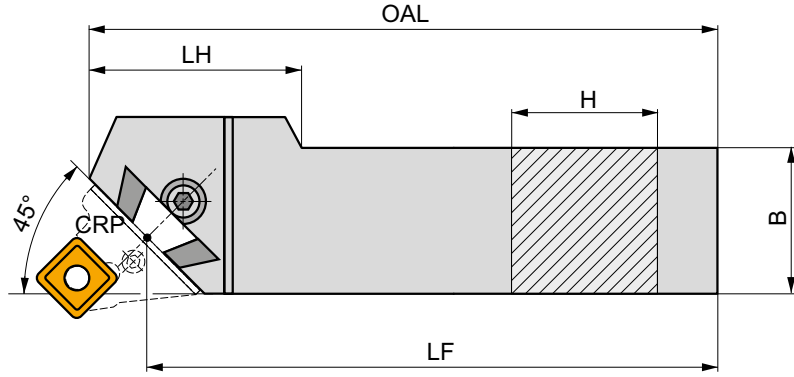
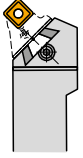

	Product	H	B	LF	OAL	LH	kg	GI098	DKH10
		(mm)	(mm)	(mm)	(mm)	(mm)			
R	DKHR 4050 V	40	50	400	425	100	7.10	GI098	DKH10
	DKHR 5060 W	50	60	450	475	110	11.30	GI098	DKH10
	DKHR 6080 W-A	60	80	450	485	90	19.65	GI098	DKH10
L	DKHL 4050 V	40	50	400	425	100	7.10	GI098	DKH10
	DKHL 5060 W	50	60	450	475	110	11.30	GI098	DKH10
	DKHL 6080 W-A	60	80	450	485	90	19.28	GI098	DKH10



GI098



KHP



KHS



DKH10



SR 14



HXK 10



SC

09/ 12/ 25/ 38

KARBÜR UÇLAR

SCGT



134

SCMT



135

SCMW



138

DOĞRU BOYUTLA EŞLEŞTİRİN (örnek)

Kesici uç

Takım Tutucu

SCMT 120408E-RM

SSDCN 2020 K 12-M-A

ISO TORNALAMA - DIŞ

SSBC(RL) EXT

75°

SC..

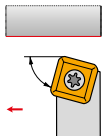
09
12
25
38
 12×12
60×60

139

134 – 138

SSDCN EXT

45°

SC..

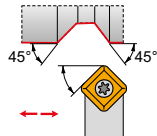
09
12
 12×12
25×25

140

134 – 138

SSKC(RL) EXT

75°

SC..

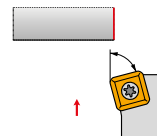
09
12
 12×12
25×25

141

134 – 138

ISO TORNALAMA - AĞIR KABA - DIŞ

KHS-SBCR + DKH(RL)

75°

SC..

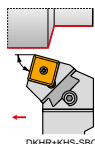
25
38

DKHR+KHS-SBC

 40×50
60×80

142, 143

134 – 138

ISO TORNALAMA - İÇ

SSSC(RL) INT

45°

SC..

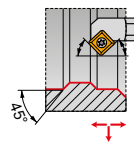

09

 25
32

144

134 – 138



SCGT



	IC (mm)	D1 (mm)	L (mm)	S (mm)
09T3	9.525	4.40	9.53	3.97
09T3-SF3	9.525	4.40	9.53	4.22
1204	12.700	5.50	12.70	4.76

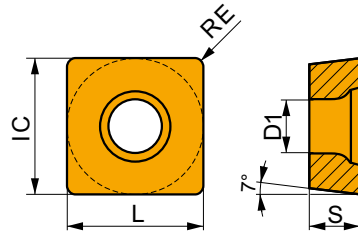

Kesme hızı (vc), ilerleme (f) ve kesme derinliği (ap) için uygunluk ve başlangıç değerleri. Daha ileri hesaplamalar için İşleme Hesaplayıcısı uygulamasına başvurun.

Product	RE (mm)	P			M			K			N			S			H		
		vc (m/min)	f (mm/rev)	ap (mm)	vc (m/min)	f (mm/rev)	ap (mm)	vc (m/min)	f (mm/rev)	ap (mm)	vc (m/min)	f (mm/rev)	ap (mm)	vc (m/min)	f (mm/rev)	ap (mm)			



AL geometri, ince finişten kabaya, ve darbesizden hafif darbeli kesmeye kadar uygun, çok pozitif tasarım.

SCGT 120408F-AL	H07	0.8	-	-	-	-	-	-	-	315	0.48	2.0	-	-	-	-	-	-
	T0315	0.8	-	-	-	-	-	-	-	465	0.48	2.0	-	-	-	-	-	-



NF1 geometri, ince finişten ortaya kadar işlemek için pozitif tasarım, darbesiz kesim için uygun.

SCGT 09T308E-NF1	H07	0.8	-	-	-	100	0.13	1.2	-	510	0.17	1.2	50	0.13	1.0	-	-	-
	T6310	0.8	200	0.14	1.2	140	0.13	1.2	-	600	0.17	1.2	60	0.13	1.0	40	0.15	1.0
	T7325	0.8	225	0.14	1.2	175	0.13	1.2	-	-	-	-	70	0.13	1.0	-	-	-
SCGT 120408E-NF1	H07	0.8	-	-	-	90	0.16	1.4	-	455	0.22	1.4	45	0.16	1.1	-	-	-
	T6310	0.8	180	0.18	1.4	125	0.16	1.4	-	540	0.22	1.4	50	0.16	1.1	35	0.15	1.0
	T7325	0.8	205	0.18	1.4	155	0.16	1.4	-	-	-	-	65	0.16	1.1	-	-	-

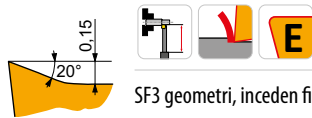

SF3 geometri, inceden finiş işlemeye kadar işlemek için çok pozitif tasarım, darbesiz kesim için uygun.

SCGT 09T304E-SF3	H07	0.4	-	-	-	95	0.09	1.0	155	0.10	1.0	495	0.12	1.0	50	0.07	0.8	-	-
	T6310	0.4	185	0.10	1.0	130	0.09	1.0	145	0.10	1.0	555	0.12	1.0	55	0.07	0.8	35	0.15
	T8315	0.4	200	0.10	1.0	120	0.09	1.0	190	0.10	1.0	600	0.12	1.0	50	0.07	0.8	40	0.15
SCGT 09T308E-SF3	T6310	0.8	210	0.12	1.0	150	0.12	1.0	165	0.12	1.0	630	0.14	1.0	60	0.11	0.8	40	0.15
	T8315	0.8	220	0.12	1.0	130	0.12	1.0	205	0.12	1.0	660	0.14	1.0	55	0.11	0.8	40	0.15



SCMT



	IC (mm)	D1 (mm)	L (mm)	S (mm)
09T3	9.525	4.40	9.53	3.97
1204	12.700	5.50	12.70	4.76
2509	25.400	8.70	25.40	9.53
3809	38.100	8.70	38.10	9.53

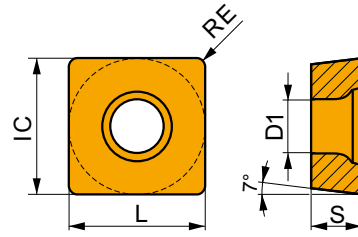

Kesme hızı (vc), ilerleme (f) ve kesme derinliği (ap) için uygunluk ve başlangıç değerleri. Daha ileri hesaplamalar için İşleme Hesaplayıcısı uygulamasına başvurun.

Product	RE (mm)	P			M			K			N			S			H		
		vc (m/min)	f (mm/rev)	ap (mm)	vc (m/min)	f (mm/rev)	ap (mm)	vc (m/min)	f (mm/rev)	ap (mm)	vc (m/min)	f (mm/rev)	ap (mm)	vc (m/min)	f (mm/rev)	ap (mm)	vc (m/min)	f (mm/rev)	ap (mm)

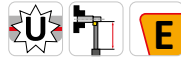
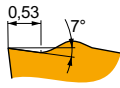

FF2 geometri, ince-finişten finişe işlemeye kadar için çok pozitif tasarım, darbesizden hafif darbeli işlemeye kadar uygun.

SCMT 09T304E-FF2	T8430	0.4	210	0.12	1.2	-	-	-	175	0.12	1.2	-	-	-	-	-	-	-	-
	T9325	0.4	260	0.12	1.2	-	-	-	245	0.12	1.2	-	-	-	-	-	-	-	-
SCMT 09T308E-FF2	T8330	0.8	185	0.17	1.2	-	-	-	175	0.17	1.2	-	-	-	-	-	-	-	-
	T8430	0.8	220	0.17	1.2	-	-	-	180	0.17	1.2	-	-	-	-	-	-	-	-
	T9325	0.8	265	0.17	1.2	-	-	-	250	0.17	1.2	-	-	-	-	-	-	-	-

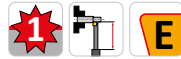
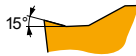

FM geometri, finişten yarı kaba işlemeye, ve darbesizden hafif darbeli kesmeye kadar uygun.

SCMT 09T304E-FM	T7325	0.4	205	0.15	1.2	155	0.15	1.2	-	-	-	-	-	-	-	-	-	-	-	
	T7335	0.4	200	0.15	1.2	155	0.15	1.2	-	-	-	-	-	-	-	-	-	-	-	
	T8315	0.4	190	0.15	1.2	110	0.14	1.2	180	0.15	1.2	570	0.18	1.2	-	-	-	-	-	
	T8330	0.4	180	0.15	1.2	105	0.14	1.2	170	0.15	1.2	540	0.18	1.2	-	-	-	-	-	
	T8430	0.4	210	0.15	1.2	115	0.14	1.2	175	0.15	1.2	585	0.18	1.2	-	-	-	-	-	
	T9315	0.4	290	0.15	1.2	-	-	-	275	0.15	1.2	-	-	-	-	-	-	-	-	-
	T9325	0.4	260	0.15	1.2	155	0.15	1.2	245	0.15	1.2	-	-	-	-	-	-	-	-	
SCMT 09T308E-FM	T7325	0.8	225	0.20	1.2	175	0.18	1.2	-	-	-	-	-	-	-	-	-	-	-	
	T7335	0.8	215	0.20	1.2	165	0.18	1.2	-	-	-	-	-	-	-	-	-	-	-	
	T8315	0.8	205	0.20	1.2	120	0.18	1.2	190	0.20	1.2	615	0.24	1.2	-	-	-	-	-	
	T8330	0.8	195	0.20	1.2	115	0.18	1.2	185	0.20	1.2	585	0.24	1.2	-	-	-	-	-	
	T8430	0.8	225	0.20	1.2	120	0.18	1.2	185	0.20	1.2	615	0.24	1.2	-	-	-	-	-	
	T9315	0.8	305	0.20	1.2	-	-	-	285	0.20	1.2	-	-	-	-	-	-	-	-	
	T9325	0.8	275	0.20	1.2	165	0.18	1.2	260	0.20	1.2	-	-	-	-	-	-	-	-	
SCMT 120404E-FM	T7325	0.4	195	0.15	1.6	150	0.15	1.6	-	-	-	-	-	-	-	-	-	-	-	
	T8315	0.4	185	0.15	1.6	110	0.14	1.6	175	0.15	1.6	555	0.18	1.6	-	-	-	-	-	
	T8330	0.4	170	0.15	1.6	100	0.14	1.6	160	0.15	1.6	510	0.18	1.6	-	-	-	-	-	
	T8430	0.4	205	0.15	1.6	110	0.14	1.6	170	0.15	1.6	570	0.18	1.6	-	-	-	-	-	
	T9315	0.4	280	0.15	1.6	-	-	-	265	0.15	1.6	-	-	-	-	-	-	-	-	
	T9325	0.4	250	0.15	1.6	150	0.15	1.6	235	0.15	1.6	-	-	-	-	-	-	-	-	
	SCMT 120408E-FM	T7325	0.8	215	0.20	1.6	165	0.18	1.6	-	-	-	-	-	-	-	-	-	-	-
T7335		0.8	210	0.20	1.6	160	0.18	1.6	-	-	-	-	-	-	-	-	-	-	-	
T8315		0.8	200	0.20	1.6	120	0.18	1.6	190	0.20	1.6	600	0.24	1.6	-	-	-	-	-	
T8330		0.8	190	0.20	1.6	110	0.18	1.6	180	0.20	1.6	570	0.24	1.6	-	-	-	-	-	
T8430		0.8	220	0.20	1.6	120	0.18	1.6	180	0.20	1.6	600	0.24	1.6	-	-	-	-	-	
T9315		0.8	300	0.20	1.6	-	-	-	285	0.20	1.6	-	-	-	-	-	-	-	-	
T9325		0.8	265	0.20	1.6	155	0.18	1.6	250	0.20	1.6	-	-	-	-	-	-	-	-	
SCMT 120412E-FM	T7325	1.2	210	0.27	1.6	160	0.24	1.6	-	-	-	-	-	-	-	-	-	-	-	
	T8330	1.2	185	0.27	1.6	110	0.24	1.6	175	0.27	1.6	555	0.32	1.6	-	-	-	-	-	
	T8430	1.2	200	0.27	1.6	110	0.24	1.6	165	0.27	1.6	555	0.32	1.6	-	-	-	-	-	
	T9315	1.2	275	0.27	1.6	-	-	-	260	0.27	1.6	-	-	-	-	-	-	-	-	
	T9325	1.2	245	0.27	1.6	145	0.24	1.6	230	0.27	1.6	-	-	-	-	-	-	-	-	



Kesme hızı (vc), ilerleme (f) ve kesme derinliği (ap) için uygunluk ve başlangıç değerleri. Daha ileri hesaplamalar için İşleme Hesaplayıcısı uygulamasına başvurun.

Product	RE  (mm)	P			M			K			N			S			H		
		vc (m/min)	f (mm/rev)	ap (mm)	vc (m/min)	f (mm/rev)	ap (mm)	vc (m/min)	f (mm/rev)	ap (mm)	vc (m/min)	f (mm/rev)	ap (mm)	vc (m/min)	f (mm/rev)	ap (mm)	vc (m/min)	f (mm/rev)	ap (mm)

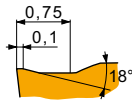

FM2 geometri, finişten orta işlemeye kadar, ve darbesizden darbeli kesmeye kadar uygun.

SCMT 09T304E-FM2	T7325	0.4	200	0.12	1.0	155	0.11	1.0	-	-	-	-	-	-	-	-	-	-
	T8430	0.4	220	0.12	1.0	120	0.11	1.0	180	0.12	1.0	-	-	-	-	-	-	-
	T9325	0.4	265	0.12	1.0	155	0.11	1.0	250	0.12	1.0	-	-	-	-	-	-	-
SCMT 09T308E-FM2	T8330	0.8	190	0.17	1.0	110	0.15	1.0	180	0.17	1.0	-	-	-	-	-	-	-
	T8430	0.8	225	0.17	1.0	120	0.15	1.0	185	0.17	1.0	-	-	-	-	-	-	-
	T9315	0.8	305	0.17	1.0	-	-	-	285	0.17	1.0	-	-	-	-	-	-	-
	T9325	0.8	270	0.17	1.0	160	0.15	1.0	255	0.17	1.0	-	-	-	-	-	-	-
	T9335	0.8	235	0.17	1.0	140	0.15	1.0	-	-	-	-	-	-	-	-	-	-

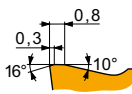

RF geometri, yarı kabadan kaba işlemeye kadar, ve darbesizden darbeli kesime kadar uygun.

SCMT 09T308E-RF	T5315	0.8	255	0.20	1.5	-	-	-	240	0.20	1.5	-	-	-	-	-	50	0.15	1.0
	T7335	0.8	170	0.20	1.5	130	0.18	1.5	-	-	-	-	-	-	-	-	-	-	
	T9325	0.8	220	0.20	1.5	130	0.18	1.5	205	0.20	1.5	-	-	-	-	-	-	-	
SCMT 120408E-RF	T5315	0.8	240	0.22	2.2	-	-	-	225	0.22	2.2	-	-	-	-	-	45	0.15	1.0
	T7335	0.8	160	0.22	2.2	120	0.22	2.2	-	-	-	-	-	-	-	-	-	-	
	T9325	0.8	205	0.22	2.2	120	0.22	2.2	190	0.22	2.2	-	-	-	-	-	-	-	

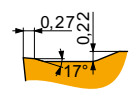

RM geometri, yarı kabadan kaba işlemeye kadar, ve darbesizden darbeli kesime kadar uygun.

SCMT 09T308E-RM	T5315	0.8	275	0.30	2.0	-	-	-	260	0.30	2.0	-	-	-	-	-	55	0.15	1.0	
	T7335	0.8	190	0.30	2.0	145	0.27	2.0	-	-	-	60	0.24	1.6	-	-	-			
	T8330	0.8	175	0.30	2.0	105	0.27	2.0	165	0.30	2.0	-	-	-	40	0.24	1.6	35	0.15	1.0
	T8430	0.8	190	0.30	2.0	105	0.27	2.0	155	0.30	2.0	-	-	-	40	0.24	1.6	30	0.15	1.0
	T9315	0.8	255	0.30	2.0	-	-	-	240	0.30	2.0	-	-	-	-	-	-	50	0.15	1.0
	T9325	0.8	230	0.30	2.0	135	0.27	2.0	215	0.30	2.0	-	-	-	50	0.24	1.6	-	-	
SCMT 120408E-RM	T5305	0.8	305	0.30	2.3	-	-	-	285	0.30	2.3	-	-	-	-	-	60	0.15	1.0	
	T5315	0.8	275	0.30	2.3	-	-	-	260	0.30	2.3	-	-	-	-	-	55	0.15	1.0	
	T7335	0.8	185	0.30	2.3	140	0.27	2.3	-	-	-	60	0.24	1.8	-	-	-			
	T8330	0.8	175	0.30	2.3	105	0.27	2.3	165	0.30	2.3	-	-	-	40	0.24	1.8	35	0.15	1.0
	T8430	0.8	190	0.30	2.3	105	0.27	2.3	155	0.30	2.3	-	-	-	40	0.24	1.8	30	0.15	1.0
	T9315	0.8	250	0.30	2.3	-	-	-	235	0.30	2.3	-	-	-	-	-	-	50	0.15	1.0
	T9325	0.8	225	0.30	2.3	135	0.27	2.3	210	0.30	2.3	-	-	-	50	0.24	1.8	-	-	

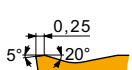

RM3 geometri, yarı kabadan kaba işlemeye kadar, ve darbesizden darbeli kesime kadar uygun.

SCMT 120408E-RM3	T6310	0.8	155	0.27	2.3	110	0.27	2.3	125	0.27	2.3	-	-	-	-	-	30	0.15	1.0
	T8330	0.8	155	0.27	2.3	90	0.27	2.3	145	0.27	2.3	-	-	-	-	-	30	0.15	1.0
	T8430	0.8	170	0.27	2.3	90	0.27	2.3	135	0.27	2.3	-	-	-	-	-	25	0.15	1.0
	T9315	0.8	225	0.27	2.3	-	-	-	210	0.27	2.3	-	-	-	-	-	45	0.15	1.0
	T9325	0.8	205	0.27	2.3	120	0.27	2.3	190	0.27	2.3	-	-	-	-	-	-	-	
	T9335	0.8	175	0.27	2.3	105	0.27	2.3	-	-	-	-	-	-	-	-	-	-	
SCMT 120412E-RM3	T7325	1.2	175	0.30	2.3	135	0.27	2.3	-	-	-	-	-	-	-	-	-	-	
	T9325	1.2	205	0.30	2.3	120	0.27	2.3	190	0.30	2.3	-	-	-	-	-	-	-	



Kesme hızı (vc), ilerleme (f) ve kesme derinliği (ap) için uygunluk ve başlangıç değerleri. Daha ileri hesaplamalar için İşleme Hesaplayıcısı uygulamasına başvurun.

Product	RE (mm)	P			M			K			N			S			H		
		vc (m/min)	f (mm/rev)	ap (mm)	vc (m/min)	f (mm/rev)	ap (mm)	vc (m/min)	f (mm/rev)	ap (mm)	vc (m/min)	f (mm/rev)	ap (mm)	vc (m/min)	f (mm/rev)	ap (mm)	vc (m/min)	f (mm/rev)	ap (mm)

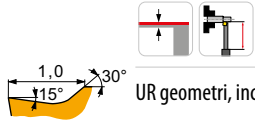

UR geometri, inceden finişe kadar işleme için, ve darbesiz ve hafif darbeleri kesim.

SCMT 09T304E-UR	T7325	0.4	175	0.15	1.2	135	0.15	1.2	-	-	-	-	-	-	-	-	-	-	
	T8330	0.4	155	0.15	1.2	90	0.14	1.2	145	0.15	1.2	-	-	-	-	-	-	-	
	T8430	0.4	180	0.15	1.2	95	0.14	1.2	145	0.15	1.2	-	-	-	-	-	-	-	
	T9315	0.4	250	0.15	1.2	-	-	-	235	0.15	1.2	-	-	-	-	-	-	-	-
	T9325	0.4	225	0.15	1.2	135	0.15	1.2	210	0.15	1.2	-	-	-	-	-	-	-	
SCMT 09T308E-UR	T5315	0.8	280	0.20	1.2	-	-	-	265	0.20	1.2	-	-	-	-	-	-	-	
	T7325	0.8	195	0.20	1.2	150	0.18	1.2	-	-	-	-	-	-	-	-	-	-	
	T8330	0.8	170	0.20	1.2	100	0.18	1.2	160	0.20	1.2	-	-	-	-	-	-	-	
	T8430	0.8	190	0.20	1.2	105	0.18	1.2	155	0.20	1.2	-	-	-	-	-	-	-	
	T9315	0.8	260	0.20	1.2	-	-	-	245	0.20	1.2	-	-	-	-	-	-	-	
SCMT 120408E-UR	T9325	0.8	235	0.20	1.2	140	0.18	1.2	220	0.20	1.2	-	-	-	-	-	-	-	
	TT310	0.8	270	0.20	1.2	160	0.18	1.2	-	-	-	-	-	-	-	-	-	-	
	T5315	0.8	270	0.20	1.6	-	-	-	255	0.20	1.6	-	-	-	-	-	-	-	
	T7325	0.8	185	0.20	1.6	140	0.18	1.6	-	-	-	-	-	-	-	-	-	-	
	T8330	0.8	165	0.20	1.6	95	0.18	1.6	155	0.20	1.6	-	-	-	-	-	-	-	
SCMT 120412E-UR	T8430	0.8	185	0.20	1.6	100	0.18	1.6	150	0.20	1.6	-	-	-	-	-	-	-	
	T9315	0.8	260	0.20	1.6	-	-	-	245	0.20	1.6	-	-	-	-	-	-	-	
	T9325	0.8	230	0.20	1.6	135	0.18	1.6	215	0.20	1.6	-	-	-	-	-	-	-	
	T8330	1.2	160	0.27	1.6	95	0.24	1.6	150	0.27	1.6	-	-	-	-	-	-	-	
	T8430	1.2	175	0.27	1.6	95	0.24	1.6	140	0.27	1.6	-	-	-	-	-	-	-	
T9325	1.2	215	0.27	1.6	125	0.24	1.6	200	0.27	1.6	-	-	-	-	-	-	-		

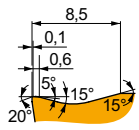

DR4 geometri, kabadan ağır kaba işleme, ve sürekliden aralıklı kesmeye kadar uygun.

SCMT 380932E-DR4	T9335	3.2	50	1.33	16.0	30	1.20	16.0	-	-	-	-	-	-	-	-	-
------------------	-------	-----	----	------	------	----	------	------	---	---	---	---	---	---	---	---	---

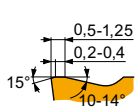

OR geometri, kabadan ağır kabaya kadar işlemek için, darbesizden darbeleri kesime kadar uygun.

SCMT 250924E-OR	T9226	2.4	80	1.00	10.0	45	0.90	10.0	75	1.00	10.0	-	-	-	15	0.70	8.0	-	-	-
	T9325	2.4	90	1.00	10.0	50	0.90	10.0	85	1.00	10.0	-	-	-	20	0.70	8.0	-	-	-
	T9335	2.4	70	1.00	10.0	40	0.90	10.0	-	-	-	-	-	-	15	0.70	8.0	-	-	-
SCMT 380932E-OR	6635	3.2	60	1.20	18.0	35	1.08	18.0	-	-	-	-	-	-	15	1.08	9.9	-	-	-
	T9226	3.2	65	1.20	18.0	35	1.08	18.0	60	1.20	18.0	-	-	-	10	1.08	9.9	-	-	-
	T9315	3.2	85	1.20	18.0	-	-	-	80	1.20	18.0	-	-	-	-	-	-	-	-	-
	T9325	3.2	80	1.20	18.0	45	1.08	18.0	75	1.20	18.0	-	-	-	15	1.08	9.9	-	-	-
	T9335	3.2	60	1.20	18.0	35	1.08	18.0	-	-	-	-	-	-	10	1.08	9.9	-	-	-

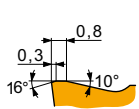

SR geometri, kabadan ağır kaba işlemeye kadar, ve darbesizden darbeleri kesime kadar uygun.

SCMT 250924E-SR	T9325	2.4	70	1.00	14.0	40	0.90	14.0	65	1.00	14.0	-	-	-	-	-	-
	T9335	2.4	60	1.00	14.0	35	0.90	14.0	-	-	-	-	-	-	-	-	-
SCMT 380932E-SR	T9335	3.2	50	1.30	20.0	30	1.30	20.0	-	-	-	-	-	-	-	-	-



SCMW



	IC	D1	L	S
	(mm)	(mm)	(mm)	(mm)
09T3	9.525	4.40	9.53	3.97
1204	12.700	5.50	12.70	4.76

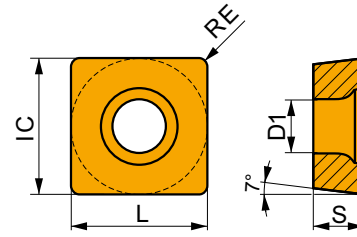

Kesme hızı (vc), ilerleme (f) ve kesme derinliği (ap) için uygunluk ve başlangıç değerleri. Daha ileri hesaplamalar için İşleme Hesaplayıcısı uygulamasına başvurun.

Product	RE (mm)	P			M			K			N			S			H		
		vc (m/min)	f (mm/rev)	ap (mm)	vc (m/min)	f (mm/rev)	ap (mm)	vc (m/min)	f (mm/rev)	ap (mm)	vc (m/min)	f (mm/rev)	ap (mm)	vc (m/min)	f (mm/rev)	ap (mm)	vc (m/min)	f (mm/rev)	ap (mm)

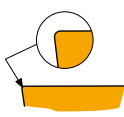

İnce finiştan yarı kaba işleme kadar ve darbesizden hafif darbeli kesmeye kadar uygun.

SCMW 09T304	T5305	0.4	–	–	–	–	–	–	–	240	0.10	2.0	–	–	–	–	–	–	–	50	0.15	1.0
	T5315	0.4	–	–	–	–	–	–	–	205	0.10	2.0	–	–	–	–	–	–	–	40	0.15	1.0
SCMW 09T308	T5305	0.8	–	–	–	–	–	–	–	220	0.20	2.0	–	–	–	–	–	–	–	45	0.15	1.0
	T5315	0.8	–	–	–	–	–	–	–	190	0.20	2.0	–	–	–	–	–	–	–	40	0.15	1.0
SCMW 120408	T5305	0.8	–	–	–	–	–	–	–	205	0.20	4.0	–	–	–	–	–	–	–	40	0.15	1.0
	T5315	0.8	–	–	–	–	–	–	–	185	0.20	4.0	–	–	–	–	–	–	–	35	0.15	1.0



SSBC(RL) EXT



PRAMET

S



SC.. Uç için Vida Sıkmalı 75° Açılı Dış Kater

Vida sıkmalı Sağ/Sol dış kater. Pozitif SC.. 0938 uçlarla çap, konik ve pah tornalama için uygundur. 12x12-60x60mm shaft ölçülerinde bulunur. Gövde uzun takım ömrü için işlem görmüştür.

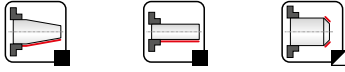
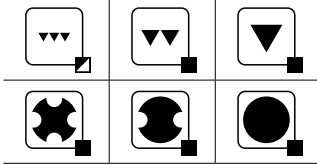
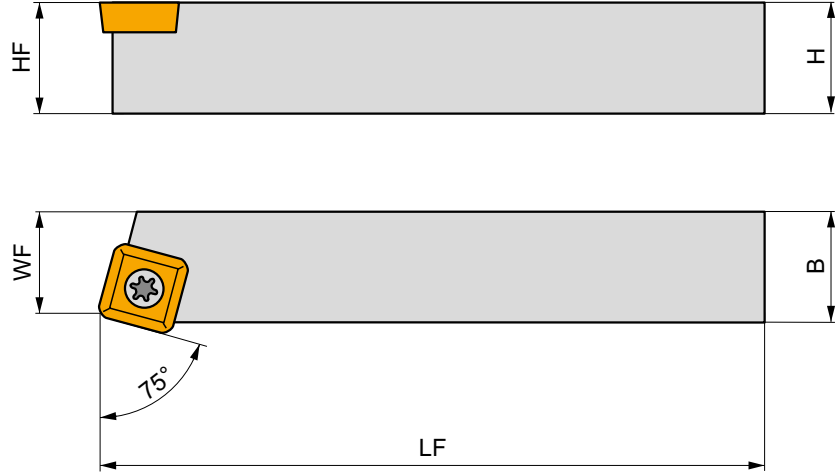
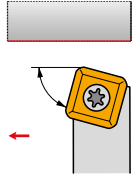

Product	H	B	HF	WF	LF	LAMS	GAMO	kg			
	(mm)	(mm)	(mm)	(mm)	(mm)	(°)	(°)				
R	SSBCR 1212 F 09	12	12	12	11	80	0	0	0.10	GI053	S08
	SSBCR 1616 H 09	16	16	16	13	100	0	0	0.20	GI053	S08
	SSBCR 2020 K 12-M-A	20	20	20	17	125	0	0	0.40	GI015	SS20
	SSBCR 2525 M 12-M-A	25	25	25	22	150	0	0	0.76	GI015	SS20
	SSBCR 4040 S 25	40	40	40	35	250	0	0	3.01	GI131	SS25
	SSBCR 5050 T 25	50	50	50	43	300	0	0	5.65	GI131	SS25
	SSBCR 5050 T 38-A	50	50	50	43	300	0	0	4.84	GI164	SS38A
SSBCR 6060 V 38-A	60	60	60	53	400	0	0	11.10	GI164	SS38A	
L	SSBCL 1212 F 09	12	12	12	11	80	0	0	0.10	GI053	S08
	SSBCL 1616 H 09	16	16	16	13	100	0	0	0.22	GI053	S08
	SSBCL 2020 K 12-M-A	20	20	20	17	125	0	0	0.40	GI015	SS20
	SSBCL 2525 M 12-M-A	25	25	25	22	150	0	0	0.47	GI015	SS20
	SSBCL 4040 S 25	40	40	40	35	250	0	0	3.01	GI131	SS25
	SSBCL 5050 T 25	50	50	50	43	300	0	0	5.65	GI131	SS25
	SSBCL 5050 T 38-A	50	50	50	43	300	0	0	5.78	GI164	SS38A
SSBCL 6060 V 38-A	60	60	60	53	400	0	0	11.16	GI164	SS38A	



GI015
GI053
GI131
GI164

SC.. 1204..
SC.. 09T3..
SC.. 2509..
SC.. 3809..



S08
SS20
SS25
SS38A

US 3510-T15P
US 5012-T15P
US 8025-T30P
US 8025-T30P

3.0
5.0
13.0
13.0

M 3.5
M 5
M 8
M 8

10.6
12.2
24.2
24.2

-
SSN 120304
SSN 250620
SSN 380920

-
MS 5008
MS 8020
MS 8020

FLAG T15P
FLAG T15P
-
-

-
HXK 5
HXK 5
HXK 5

-
-
SDR T30P
SDR T30P



SSDCN EXT

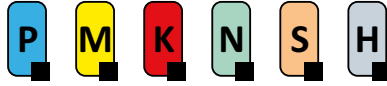

PRAMET

S



SC.. Uç için Vida Sıkmalı 45° Açılı Dış Kater

Vida sıkmalı nötr dış kater. Pozitif SC.. 09 ve 12 uçlarla çap, kopya, konik ve pah tornalama için uygundur. 12x12-25x25mm mevcuttur. Gövde uzun takım ömrü için işlem görmüştür.

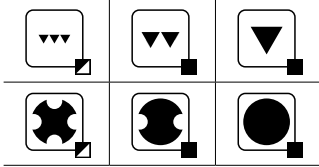
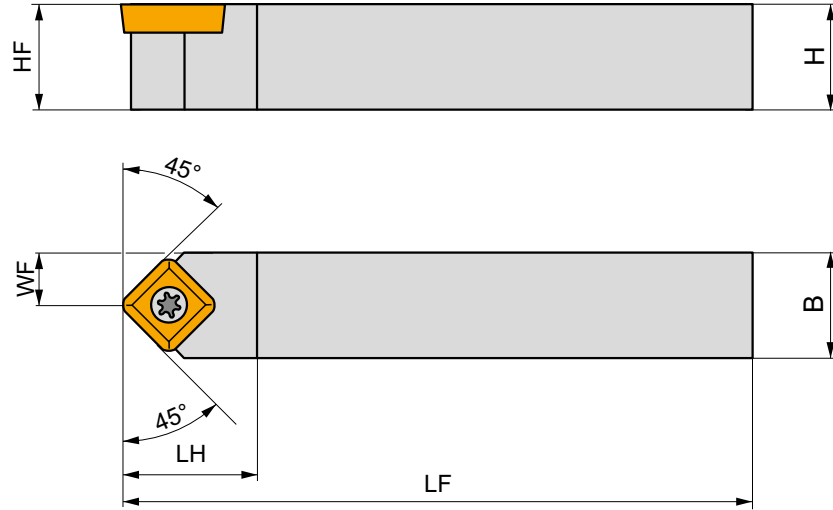
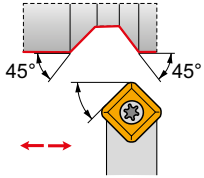

Product	H	B	HF	WF	LF	LH	LAMS	GAMO	kg		
	(mm)	(mm)	(mm)	(mm)	(mm)	(mm)	(°)	(°)			
SSDCN 1212 F 09	12	12	12	6	80	-	0	0	0.12	GI053	S08
SSDCN 1616 H 09	16	16	16	8	100	-	0	0	0.20	GI053	S08
SSDCN 2020 K 12-M-A	20	20	20	10	125	-	0	0	0.42	GI015	SS20
SSDCN 2525 M 12-M-A	25	25	25	12.5	150	-	0	0	0.74	GI015	SS20



GI015

SC.. 1204..

GI053

SC.. 09T3..



S08

US 3510-T15P

3.0

M 3.5

10.6

-

-

FLAG T15P

-

SS20

US 5012-T15P

5.0

M 5

12.2

SSN 120304

MS 5008

FLAG T15P

HXK 5



SSKC(RL) EXT



PRAMET

S



SC.. Uç için Vida Sıkmalı 75° (Alın) Açılı Dış Kater

Vida sıkımalı Sağ/Sol dış kater. Pozitif SC.. 09 ve 12 uçlarla alın ve pah tormalama için uygundur. 12x12-25x25mm shaft ölçülerinde bulunur. Gövde uzun takım ömrü için işlem görmüştür.

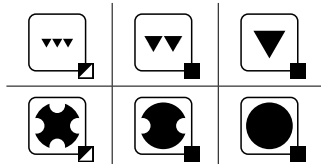
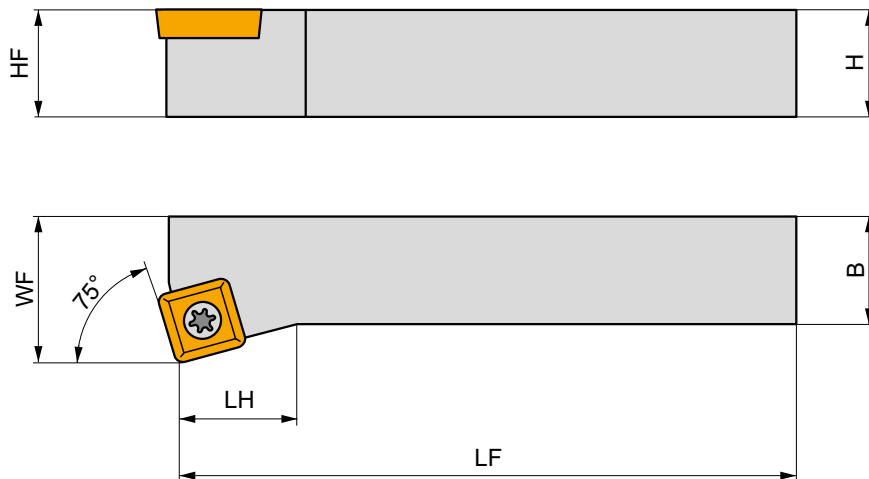
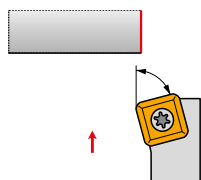

Product	H (mm)	B (mm)	HF (mm)	WF (mm)	LF (mm)	LH (mm)	LAMS (°)	GAMO (°)	kg	GI015	GI053	S08	SS20
R SSKCR 1212 F 09	12	12	12	16	80	32	0	0	0.10	GI053		S08	
SSKCR 1616 H 09	16	16	16	20	100	32	0	0	0.25	GI053		S08	
SSKCR 2020 K 12-M-A	20	20	20	25	125	36	0	0	0.75	GI015		SS20	
SSKCR 2525 M 12-M-A	25	25	25	32	150	36	0	0	0.75	GI015		SS20	
L SSKCL 1212 F 09	12	12	12	16	80	32	0	0	0.10	GI053		S08	
SSKCL 1616 H 09	16	16	16	20	100	32	0	0	0.22	GI053		S08	
SSKCL 2020 K 12-M-A	20	20	20	25	125	36	0	0	0.45	GI015		SS20	
SSKCL 2525 M 12-M-A	25	25	25	32	150	36	0	0	0.80	GI015		SS20	



GI015

SC.. 1204..

GI053

SC.. 09T3..



S08

US 3510-T15P

3.0

M 3.5

10.6

-

-

FLAG T15P

-

SS20

US 5012-T15P

5.0

M 5

12.2

SSN 120304

MS 5008

FLAG T15P

HXK 5



KHS-SBC(RL)



PRAMET

S



Modüler KHS Vida Sıkma Kartuşu, 75° Kesme Açılı, SC.. Uç için

DKH takım tutucu shaft için kırılmalı bağlantılı, 75° açılı Sağ/Sol vida sıkma kartuşu. Pozitif SC.. 25 veya 38 uçlarla çap, alın, konik ve pah tornalamak için uygundur. Tutucu uzun takım ömrü için işlem görmüştür.

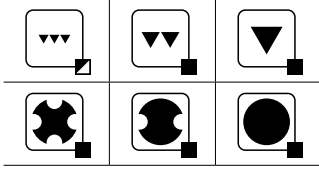
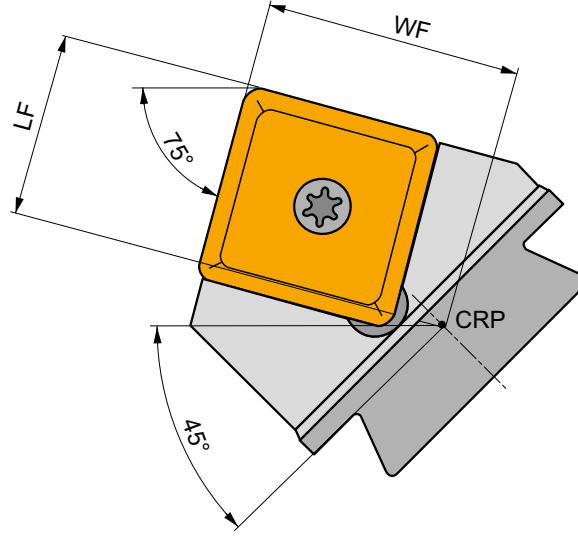
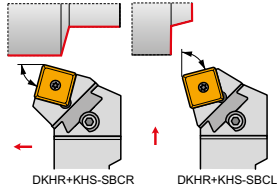

Product	WF	LF	LAMS	GAMO	kg	G1131 G1164	SS26 SS38
	(mm)	(mm)	(°)	(°)			
R KHS-SBCR 25	47	36	0	0	1.50	G1131	SS26
KHS-SBCR 38-A	47	36	0	0	1.50	G1164	SS38
L KHS-SBCL 25	47	36	0	0	1.45	G1131	SS26
KHS-SBCL 38-A	47	36	0	0	1.48	G1164	SS38

G1131		G1164	
SC.. 2509..		SC.. 3809..	

SS26	US 8025-T30P	13.0	M 8	24.2	SSN 250620	MS 8020	SDR T30P	HXK 5
SS38	US 8025-T30P	13.0	M 8	24.2	SSN 380620	MS 8020	SDR T30P	HXK 5



DKH(RL)

PRAMET



KHP/KHS Ağır Tornalama Kartuşları için Dış Kater Şaftı

KHP/KHS kartuşlar için kırılmalı Sağ/Sol takım şaftı. Ağır tornalama için uygundur. 40x50'den 60x80mm'ye kadar mevcut. Gövde uzun takım ömrü için işlem görmüştür.

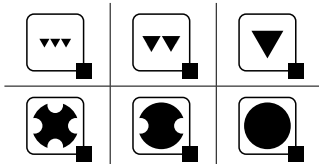
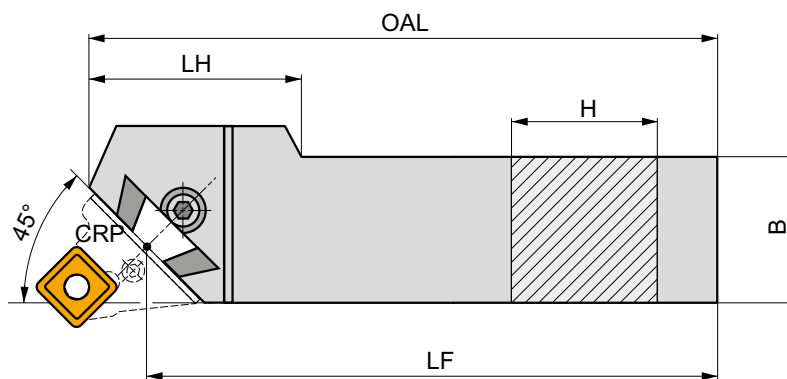
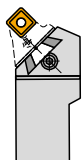

Product	H	B	LF	OAL	LH	kg		
	(mm)	(mm)	(mm)	(mm)	(mm)			
R	DKHR 4050 V	40	50	400	425	7.10	GI098	DKH10
	DKHR 5060 W	50	60	450	475	11.30	GI098	DKH10
	DKHR 6080 W-A	60	80	450	485	19.65	GI098	DKH10
L	DKHL 4050 V	40	50	400	425	7.10	GI098	DKH10
	DKHL 5060 W	50	60	450	475	11.30	GI098	DKH10
	DKHL 6080 W-A	60	80	450	485	19.28	GI098	DKH10



GI098



KHP



KHS



DKH10



SR 14



HXK 10



SSSC(RL) INT

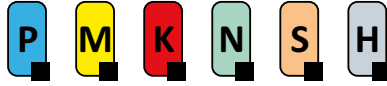

PRAMET

S



SC.. Uç için Vida Sıkmalı 45° Açılı Delik Kateri

Vida sıkmalı Sağ/Sol 45° delik kateri. Pozitif SC.. 09 uçlarla minimum Ø25mm ters pah, konik, çok yönlü, çap ve pah tornalama için uygundur. Ø20-25mm shaft ölçülerinde bulunur. Gövde uzun takım ömrü için işlem görmüştür.

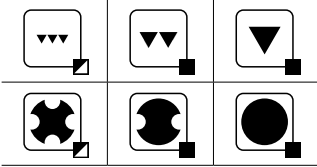
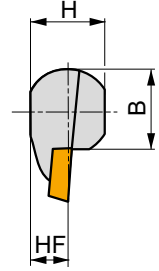
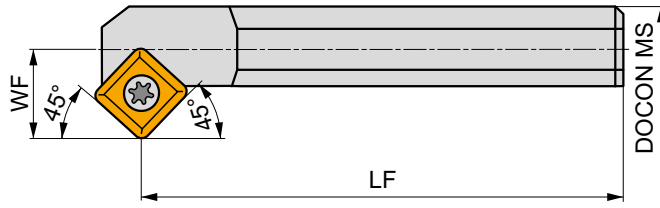
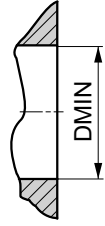
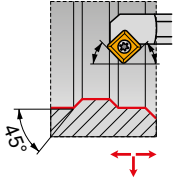

Product	DOCON MS	DMIN	WF	H	B	LF	LAMS	GAMO	kg	G1053	S04
	(mm)	(mm)	(mm)	(mm)	(mm)	(mm)	(°)	(°)			
R S20S-SSSCR 09	20	25	13	18	18.5	250	-5	0	0.61	G1053	S04
	S25T-SSSCR 09	25	32	17	23	23	300	-3	0	1.15	G1053
L S20S-SSSCL 09	20	25	13	18	18.5	250	-5	0	0.05	G1053	S04
	S25T-SSSCL 09	25	32	17	23	23	300	-3	0	1.11	G1053



G1053



SC..09T3..



S04



US 3510-T15P



3.0



M 3.5



10.6



FLAGT15P

**SP**

09/ 12/ 15/ 19/ 25

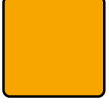
KARBÜR UÇLAR**SPMR**

146

SPUN

146

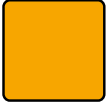
CER UÇLAR**SPGN CER**

147



SPMR



	IC (mm)	L (mm)	S (mm)
0903	9.525	9.53	3.18
1203	12.700	12.70	3.18

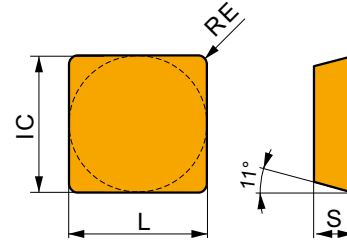

Kesme hızı (vc), ilerleme (f) ve kesme derinliği (ap) için uygunluk ve başlangıç değerleri. Daha ileri hesaplamalar için İşleme Hesaplayıcısı uygulamasına başvurun.

Product	RE (mm)	P			M			K			N			S			H		
		vc (m/min)	f (mm/rev)	ap (mm)	vc (m/min)	f (mm/rev)	ap (mm)	vc (m/min)	f (mm/rev)	ap (mm)	vc (m/min)	f (mm/rev)	ap (mm)	vc (m/min)	f (mm/rev)	ap (mm)			

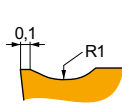

Geometri 46, inceden finiş işlemeye kadar, ve darbesizden darbeli kesime kadar uygun.

SPMR 090304E-46	T9325	0.4	215	0.15	1.0	125	0.15	1.0	200	0.15	1.0	-	-	-	-	-	-
SPMR 090308E-46	T9325	0.8	255	0.15	1.0	150	0.15	1.0	240	0.15	1.0	-	-	-	-	-	-

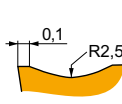

Geometri 48, finişten yarı kaba işlemeye kadar, ve darbesizden darbeli kesime kadar uygun.

SPMR 120304E-48	T9325	0.4	170	0.22	2.2	100	0.22	2.2	160	0.22	2.2	-	-	-	-	-	-
	T9335	0.4	145	0.22	2.2	85	0.22	2.2	-	-	-	-	-	-	-	-	-
SPMR 120308E-48	6640	0.8	160	0.22	2.2	95	0.22	2.2	150	0.22	2.2	-	-	-	-	-	-
	T9325	0.8	205	0.22	2.2	120	0.22	2.2	190	0.22	2.2	-	-	-	-	-	-
	T9335	0.8	175	0.22	2.2	105	0.22	2.2	-	-	-	-	-	-	-	-	-
SPMR 120312E-48	T9325	1.2	215	0.22	2.2	125	0.22	2.2	200	0.22	2.2	-	-	-	-	-	-

SPUN



	IC (mm)	L (mm)	M (mm)	S (mm)
1203	12.700	12.70	2	3.18
1504	15.875	15.88	3	4.76
1904	19.050	19.05	3	4.76
2506	25.400	25.40	4	6.35

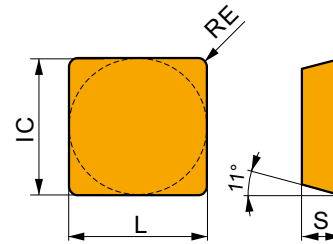

Kesme hızı (vc), ilerleme (f) ve kesme derinliği (ap) için uygunluk ve başlangıç değerleri. Daha ileri hesaplamalar için İşleme Hesaplayıcısı uygulamasına başvurun.

Product	RE (mm)	P			M			K			N			S			H		
		vc (m/min)	f (mm/rev)	ap (mm)	vc (m/min)	f (mm/rev)	ap (mm)	vc (m/min)	f (mm/rev)	ap (mm)	vc (m/min)	f (mm/rev)	ap (mm)	vc (m/min)	f (mm/rev)	ap (mm)			

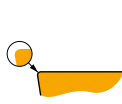

İnce finişten yarı kaba işlemeye kadar ve darbesizden hafif darbeli kesmeye kadar uygun.

SPUN 120308	6640	0.8	180	0.15	4.0	-	-	-	170	0.15	4.0	-	-	-	-	-	-
SPUN 120312	6640	1.2	190	0.15	4.0	-	-	-	180	0.15	4.0	-	-	-	-	-	-
SPUN 150408	6640	0.8	155	0.20	5.0	-	-	-	145	0.20	5.0	-	-	-	-	-	-



Kesme hızı (vc), ilerleme (f) ve kesme derinliği (ap) için uygunluk ve başlangıç değerleri. Daha ileri hesaplamalar için İşleme Hesaplayıcısı uygulamasına başvurun.

Product	RE (mm)	P			M			K			N			S			H		
		vc (m/min)	f (mm/rev)	ap (mm)	vc (m/min)	f (mm/rev)	ap (mm)	vc (m/min)	f (mm/rev)	ap (mm)	vc (m/min)	f (mm/rev)	ap (mm)	vc (m/min)	f (mm/rev)	ap (mm)	vc (m/min)	f (mm/rev)	ap (mm)



İnce finiştan yarı kaba işleme kadar ve darbesizden hafif darbeli kesmeye kadar uygun.

SPUN 150412	6640	1.2	165	0.20	5.0	–	–	–	155	0.20	5.0	–	–	–	–	–	–	–	–
SPUN 190408	6640	0.8	150	0.20	6.0	–	–	–	140	0.20	6.0	–	–	–	–	–	–	–	–
SPUN 190412	6640	1.2	160	0.20	6.0	–	–	–	150	0.20	6.0	–	–	–	–	–	–	–	–
SPUN 190416	6640	1.6	165	0.20	6.0	–	–	–	155	0.20	6.0	–	–	–	–	–	–	–	–

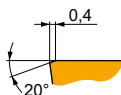

İnce finiştan yarı kaba işleme kadar ve darbesizden hafif darbeli kesmeye kadar uygun.

SPUN 250620S	6640	2.0	80	0.40	12.0	–	–	–	75	0.40	12.0	–	–	–	–	–	–	–	–
--------------	------	-----	----	------	------	---	---	---	----	------	------	---	---	---	---	---	---	---	---

SPGN CER



	IC (mm)	L (mm)	S (mm)
1203	12.700	12.70	3.18

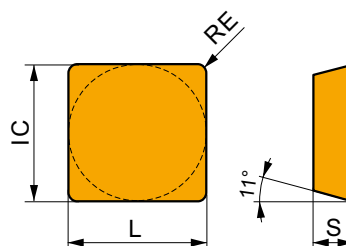

Kesme hızı (vc), ilerleme (f) ve kesme derinliği (ap) için uygunluk ve başlangıç değerleri. Daha ileri hesaplamalar için İşleme Hesaplayıcısı uygulamasına başvurun.

Product	RE (mm)	P			M			K			N			S			H		
		vc (m/min)	f (mm/rev)	ap (mm)	vc (m/min)	f (mm/rev)	ap (mm)	vc (m/min)	f (mm/rev)	ap (mm)	vc (m/min)	f (mm/rev)	ap (mm)	vc (m/min)	f (mm/rev)	ap (mm)	vc (m/min)	f (mm/rev)	ap (mm)

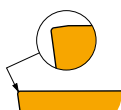

Yüksek hızlı işleme ve darbesiz kesme için.

SPGN 120308 T01020	TC100	0.8	–	–	–	–	–	–	530	0.20	1.5	–	–	–	–	–	–	–	–
--------------------	-------	-----	---	---	---	---	---	---	-----	------	-----	---	---	---	---	---	---	---	---



TC

06/ 09/ 11/16

KARBÜR UÇLAR

TCGT	TCMT	TCMW
149	150	154

KARBÜR UÇLAR

TCGW CBN
154

DOĞRU BOYUTLA EŞLEŞTİRİN (örnek)

Kesici uç	Takım Tutucu
TCMT 110204E-FF2	STFCR 1616 H 11

ISO TORNALAMA - DIŞ

STFC(RL) EXT		STFC(RL)-A EXT		STJC(RL) EXT	
90°	TC..	90°	TC..	93°	TC..
	 11 16		 11		 11 16
16x16 25x25	155	20x20	156	16x16 25x25	157
149 – 154	149 – 154	149 – 154	149 – 154	149 – 154	149 – 154

ISO TORNALAMA - İÇ

STFC(RL) INT		STFC(RL)-E INT	
90°	TC..	90°	TC..
	 06 09 11 16		 06 09 11
8,5 40	158	8,5 20	160
149 – 154	149 – 154	149 – 154	149 – 154



TCGT



	IC (mm)	D1 (mm)	L (mm)	S (mm)
06T1	3.970	2.20	6.90	1.98
0902	5.560	2.50	9.60	2.38
1102	6.350	2.80	11.00	2.38
1102-SF3	6.350	2.80	11.00	2.58
16T3	9.525	4.40	16.50	3.97
16T3-SF3	9.525	4.40	16.50	4.22

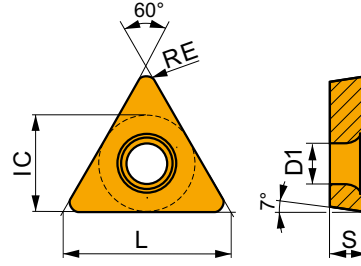

Kesme hızı (vc), ilerleme (f) ve kesme derinliği (ap) için uygunluk ve başlangıç değerleri. Daha ileri hesaplamalar için İşleme Hesaplayıcısı uygulamasına başvurun.

Product	RE (mm)	P			M			K			N			S			H		
		vc (m/min)	f (mm/rev)	ap (mm)	vc (m/min)	f (mm/rev)	ap (mm)	vc (m/min)	f (mm/rev)	ap (mm)	vc (m/min)	f (mm/rev)	ap (mm)	vc (m/min)	f (mm/rev)	ap (mm)			



AL geometri, ince finiştan kabaya, ve darbesizden hafif darbeli kesmeye kadar uygun, çok pozitif tasarım.

TCGT 090202F-AL	HF7	0.2	-	-	-	-	-	-	-	375	0.12	1.0	-	-	-	-	-	-
	T0315	0.2	-	-	-	-	-	-	-	555	0.12	1.0	-	-	-	-	-	-
TCGT 090204F-AL	HF7	0.4	-	-	-	-	-	-	-	300	0.24	1.0	-	-	-	-	-	-
	T0315	0.4	-	-	-	-	-	-	-	450	0.24	1.0	-	-	-	-	-	-
TCGT 110202F-AL	HF7	0.2	-	-	-	-	-	-	-	360	0.12	1.5	-	-	-	-	-	-
	T0315	0.2	-	-	-	-	-	-	-	525	0.12	1.5	-	-	-	-	-	-
TCGT 110204F-AL	HF7	0.4	-	-	-	-	-	-	-	285	0.24	1.5	-	-	-	-	-	-
	T0315	0.4	-	-	-	-	-	-	-	420	0.24	1.5	-	-	-	-	-	-
TCGT 110208F-AL	HF7	0.8	-	-	-	-	-	-	-	270	0.48	1.5	-	-	-	-	-	-
TCGT 16T304F-AL	HF7	0.4	-	-	-	-	-	-	-	285	0.24	2.4	-	-	-	-	-	-
	T0315	0.4	-	-	-	-	-	-	-	405	0.24	2.4	-	-	-	-	-	-
TCGT 16T308F-AL	HF7	0.8	-	-	-	-	-	-	-	255	0.48	2.4	-	-	-	-	-	-
	T0315	0.8	-	-	-	-	-	-	-	360	0.48	2.4	-	-	-	-	-	-

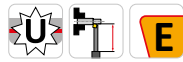
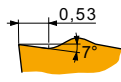

FF2 geometri, ince-finiştan finişe işlemeye kadar için çok pozitif tasarım, darbesizden hafif darbeli işlemeye kadar uygun.

TCGT 06T102E-FF2	T8330	0.2	175	0.05	0.8	-	-	-	165	0.05	0.8	-	-	-	-	-	-	-
	T8430	0.2	235	0.05	0.8	-	-	-	190	0.05	0.8	-	-	-	-	-	-	-
	TT010	0.2	295	0.05	0.5	-	-	-	-	-	-	-	-	-	-	-	-	-
TCGT 090202E-FF2	TT010	0.2	295	0.05	0.5	-	-	-	-	-	-	-	-	-	-	-	-	-

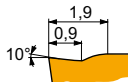
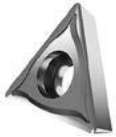

NF1 geometri, ince finiştan ortaya kadar işlemek için pozitif tasarım, darbesiz kesim için uygun.

TCGT 110204E-NF1	H07	0.4	-	-	-	80	0.09	0.8	-	415	0.12	0.8	40	0.08	0.6	-	-	-
	T6310	0.4	155	0.10	0.8	110	0.09	0.8	-	465	0.12	0.8	45	0.08	0.6	30	0.15	1.0
	T7325	0.4	180	0.10	0.8	140	0.09	0.8	-	-	-	-	55	0.08	0.6	-	-	-

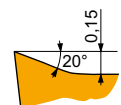

SF3 geometri, inceden finiş işlemeye kadar işlemek için çok pozitif tasarım, darbesiz kesim için uygun.

TCGT 110202E-SF3	T6310	0.2	175	0.05	0.8	125	0.05	0.8	140	0.05	0.8	525	0.06	0.8	50	0.04	0.6	35	0.15	1.0
	T8315	0.2	185	0.05	0.8	110	0.05	0.8	175	0.05	0.8	555	0.06	0.8	45	0.04	0.6	35	0.15	1.0
TCGT 110204E-SF3	H07	0.4	-	-	-	80	0.09	0.8	130	0.10	0.8	415	0.12	0.8	40	0.07	0.6	-	-	-
	T6310	0.4	155	0.10	0.8	110	0.09	0.8	125	0.10	0.8	465	0.12	0.8	45	0.07	0.6	30	0.15	1.0
	T8315	0.4	165	0.10	0.8	95	0.09	0.8	155	0.10	0.8	495	0.12	0.8	40	0.07	0.6	30	0.15	1.0



Kesme hızı (vc), ilerleme (f) ve kesme derinliği (ap) için uygunluk ve başlangıç değerleri. Daha ileri hesaplamalar için İşleme Hesaplayıcısı uygulamasına başvurun.

Product	RE (mm)	P			M			K			N			S			H		
		vc (m/min)	f (mm/rev)	ap (mm)	vc (m/min)	f (mm/rev)	ap (mm)	vc (m/min)	f (mm/rev)	ap (mm)	vc (m/min)	f (mm/rev)	ap (mm)	vc (m/min)	f (mm/rev)	ap (mm)	vc (m/min)	f (mm/rev)	ap (mm)

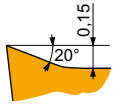

SF3 geometri, inceden finiş işlemeye kadar işlemek için çok pozitif tasarım, darbesiz kesim için uygun.

TCGT 16T304E-SF3	H07	0.4	–	–	–	80	0.09	1.0	125	0.10	1.0	405	0.12	1.0	40	0.07	0.8	–	–	–
	T6310	0.4	150	0.10	1.0	105	0.09	1.0	120	0.10	1.0	450	0.12	1.0	45	0.07	0.8	30	0.15	1.0
	T8315	0.4	160	0.10	1.0	95	0.09	1.0	150	0.10	1.0	480	0.12	1.0	40	0.07	0.8	30	0.15	1.0
TCGT 16T308E-SF3	H07	0.8	–	–	–	90	0.09	1.2	145	0.10	1.2	470	0.12	1.2	45	0.08	1.0	–	–	–
	T6310	0.8	175	0.10	1.2	125	0.09	1.2	140	0.10	1.2	525	0.12	1.2	50	0.08	1.0	35	0.15	1.0
	T8315	0.8	185	0.10	1.2	110	0.09	1.2	175	0.10	1.2	555	0.12	1.2	45	0.08	1.0	35	0.15	1.0
TCGT 16T312E-SF3	T6310	1.2	150	0.20	1.2	105	0.18	1.2	120	0.20	1.2	450	0.24	1.2	45	0.14	1.0	30	0.15	1.0

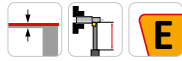

ER-SI geometri, çok pozitif sağ kesme yönlü tasarım, ince finişten yarı kaba işlemeye kadar, ve darbesiz kesim için uygun.

TCGT 110202ER-SI	T8315	0.2	190	0.10	0.8	110	0.09	0.8	180	0.10	0.8	–	–	–	45	0.08	0.6	–	–	–
	T8330	0.2	180	0.10	0.8	105	0.09	0.8	170	0.10	0.8	–	–	–	45	0.08	0.6	–	–	–
	T8430	0.2	225	0.10	0.8	120	0.09	0.8	185	0.10	0.8	–	–	–	45	0.08	0.6	–	–	–
TCGT 110204ER-SI	T8330	0.4	180	0.12	0.8	105	0.11	0.8	170	0.12	0.8	–	–	–	45	0.10	0.6	–	–	–
	T8430	0.4	225	0.12	0.8	120	0.11	0.8	185	0.12	0.8	–	–	–	45	0.10	0.6	–	–	–

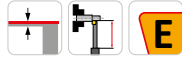

EL-SI geometri, çok pozitif sol kesme yönlü tasarım, ince finişten yarı kaba işlemeye kadar, ve darbesiz kesim için uygun.

TCGT 110202EL-SI	T8315	0.2	190	0.10	0.8	110	0.09	0.8	180	0.10	0.8	–	–	–	45	0.08	0.6	–	–	–
	T8330	0.2	180	0.10	0.8	105	0.09	0.8	170	0.10	0.8	–	–	–	45	0.08	0.6	–	–	–
	T8430	0.2	225	0.10	0.8	120	0.09	0.8	185	0.10	0.8	–	–	–	45	0.08	0.6	–	–	–
TCGT 110204EL-SI	T8315	0.4	195	0.12	0.8	115	0.11	0.8	185	0.12	0.8	–	–	–	45	0.10	0.6	–	–	–
	T8330	0.4	180	0.12	0.8	105	0.11	0.8	170	0.12	0.8	–	–	–	45	0.10	0.6	–	–	–
	T8430	0.4	225	0.12	0.8	120	0.11	0.8	185	0.12	0.8	–	–	–	45	0.10	0.6	–	–	–

TCMT

PRAMET

	IC (mm)	D1 (mm)	L (mm)	S (mm)
06T1	3.970	2.20	6.90	1.98
0902	5.560	2.50	9.60	2.38
1102	6.350	2.80	11.00	2.38
16T3	9.525	4.40	16.50	3.97

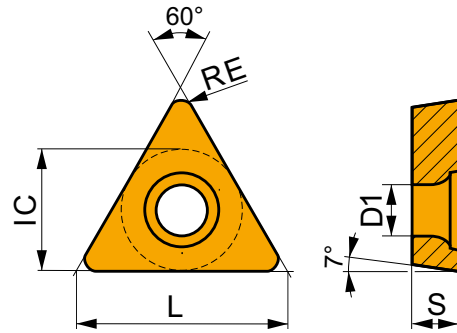

Kesme hızı (vc), ilerleme (f) ve kesme derinliği (ap) için uygunluk ve başlangıç değerleri. Daha ileri hesaplamalar için İşleme Hesaplayıcısı uygulamasına başvurun.

Product	RE (mm)	P			M			K			N			S			H		
		vc (m/min)	f (mm/rev)	ap (mm)	vc (m/min)	f (mm/rev)	ap (mm)	vc (m/min)	f (mm/rev)	ap (mm)	vc (m/min)	f (mm/rev)	ap (mm)	vc (m/min)	f (mm/rev)	ap (mm)	vc (m/min)	f (mm/rev)	ap (mm)

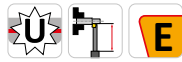
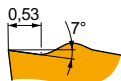

FF2 geometri, ince-finişten finiş işlemeye kadar için çok pozitif tasarım, darbesizden hafif darbeleri işlemeye kadar uygun.

TCMT 06T102E-FF2	T8330	0.2	175	0.05	0.8	–	–	–	165	0.05	0.8	–	–	–	–	–	–	–	–	–
	T8430	0.2	235	0.05	0.8	–	–	–	190	0.05	0.8	–	–	–	–	–	–	–	–	–
	T9315	0.2	335	0.05	0.8	–	–	–	315	0.05	0.8	–	–	–	–	–	–	–	–	–



Kesme hızı (vc), ilerleme (f) ve kesme derinliği (ap) için uygunluk ve başlangıç değerleri. Daha ileri hesaplamalar için İşleme Hesaplayıcısı uygulamasına başvurun.

Product	RE (mm)	P			M			K			N			S			H		
		vc (m/min)	f (mm/rev)	ap (mm)	vc (m/min)	f (mm/rev)	ap (mm)	vc (m/min)	f (mm/rev)	ap (mm)	vc (m/min)	f (mm/rev)	ap (mm)	vc (m/min)	f (mm/rev)	ap (mm)	vc (m/min)	f (mm/rev)	ap (mm)

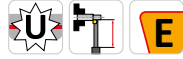
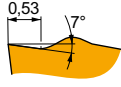

FF2 geometri, ince-finişten finişe işlemeye kadar için çok pozitif tasarım, darbesizden hafif darbeli işlemeye kadar uygun.

TCMT 06T104E-FF2	T7325	0.4	✓	170	0.12	0.8	-	-	-	-	-	-	-	-	-	-	-	-
	T8330	0.4	■	145	0.12	0.8	-	-	-	■	135	0.12	0.8	-	-	-	-	-
	T8430	0.4	■	180	0.12	0.8	-	-	-	✓	145	0.12	0.8	-	-	-	-	-
	T9315	0.4	■	245	0.12	0.8	-	-	-	✓	230	0.12	0.8	-	-	-	-	-
	T9325	0.4	■	220	0.12	0.8	-	-	-	✓	205	0.12	0.8	-	-	-	-	-
TCMT 090204E-FF2	T5315	0.4	✓	240	0.12	1.0	-	-	-	■	225	0.12	1.0	-	-	-	-	-
	T7325	0.4	✓	165	0.12	1.0	-	-	-	-	-	-	-	-	-	-	-	
	T8330	0.4	■	140	0.12	1.0	-	-	-	■	130	0.12	1.0	-	-	-	-	
	T8430	0.4	■	175	0.12	1.0	-	-	-	✓	140	0.12	1.0	-	-	-	-	
	T9315	0.4	■	240	0.12	1.0	-	-	-	✓	225	0.12	1.0	-	-	-	-	
TCMT 110204E-FF2	T7325	0.4	✓	170	0.12	0.8	-	-	-	-	-	-	-	-	-	-	-	
	T8330	0.4	■	145	0.12	0.8	-	-	-	■	135	0.12	0.8	-	-	-	-	
	T8430	0.4	■	180	0.12	0.8	-	-	-	✓	145	0.12	0.8	-	-	-	-	
	T9315	0.4	■	245	0.12	0.8	-	-	-	✓	230	0.12	0.8	-	-	-	-	
	T9325	0.4	■	220	0.12	0.8	-	-	-	✓	205	0.12	0.8	-	-	-	-	
TCMT 110208E-FF2	T7325	0.8	✓	180	0.17	0.8	-	-	-	-	-	-	-	-	-	-	-	
	T8330	0.8	■	155	0.17	0.8	-	-	-	■	145	0.17	0.8	-	-	-	-	
	T8430	0.8	■	185	0.17	0.8	-	-	-	✓	150	0.17	0.8	-	-	-	-	
	T9315	0.8	■	250	0.17	0.8	-	-	-	✓	235	0.17	0.8	-	-	-	-	
	T9325	0.8	■	225	0.17	0.8	-	-	-	✓	210	0.17	0.8	-	-	-	-	
TCMT 16T304E-FF2	T7325	0.4	✓	170	0.12	0.8	-	-	-	-	-	-	-	-	-	-	-	
	T8330	0.4	■	145	0.12	0.8	-	-	-	■	135	0.12	0.8	-	-	-	-	
	T8430	0.4	■	180	0.12	0.8	-	-	-	✓	145	0.12	0.8	-	-	-	-	
	T9315	0.4	■	245	0.12	0.8	-	-	-	✓	230	0.12	0.8	-	-	-	-	
	T9325	0.4	■	220	0.12	0.8	-	-	-	✓	205	0.12	0.8	-	-	-	-	
	T9335	0.4	■	185	0.12	0.8	-	-	-	-	-	-	-	-	-	-	-	
TCMT 16T308E-FF2	TT010	0.4	■	295	0.06	0.5	-	-	-	-	-	-	-	-	-	-	-	
	T7325	0.8	✓	180	0.17	0.8	-	-	-	-	-	-	-	-	-	-	-	
	T8330	0.8	■	155	0.17	0.8	-	-	-	■	145	0.17	0.8	-	-	-	-	
	T8430	0.8	■	185	0.17	0.8	-	-	-	✓	150	0.17	0.8	-	-	-	-	
	T9315	0.8	■	250	0.17	0.8	-	-	-	✓	235	0.17	0.8	-	-	-	-	
	T9325	0.8	■	225	0.17	0.8	-	-	-	✓	210	0.17	0.8	-	-	-	-	

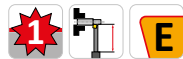

FM geometri, finişten yarı kaba işlemeye, ve darbesizden hafif darbeli kesmeye kadar uygun.

TCMT 110202E-FM	T7325	0.2	✓	185	0.10	0.8	■	140	0.09	0.8	-	-	-	-	-	-	-	
	T7335	0.2	✓	185	0.10	0.8	■	140	0.09	0.8	-	-	-	-	-	-	-	
	T8315	0.2	✓	170	0.10	0.8	■	100	0.09	0.8	✓	160	0.10	0.8	✓	510	0.12	0.8
	T8330	0.2	■	160	0.10	0.8	■	95	0.09	0.8	✓	150	0.10	0.8	✓	480	0.12	0.8
	T8430	0.2	■	195	0.10	0.8	■	105	0.09	0.8	✓	160	0.10	0.8	✓	540	0.12	0.8
	T9315	0.2	■	270	0.10	0.8	-	-	-	✓	255	0.10	0.8	-	-	-	-	
TCMT 110204E-FM	T9325	0.2	■	245	0.10	0.8	■	145	0.09	0.8	✓	230	0.10	0.8	-	-	-	
	T7325	0.4	✓	160	0.19	0.8	■	120	0.17	0.8	-	-	-	-	-	-	-	
	T7335	0.4	✓	155	0.19	0.8	■	120	0.17	0.8	-	-	-	-	-	-	-	
	T8315	0.4	✓	170	0.12	0.8	■	100	0.11	0.8	✓	160	0.12	0.8	✓	510	0.14	0.8
	T8330	0.4	■	160	0.12	0.8	■	95	0.11	0.8	✓	150	0.12	0.8	✓	480	0.14	0.8
	T8430	0.4	■	195	0.12	0.8	■	105	0.11	0.8	✓	160	0.12	0.8	✓	540	0.14	0.8
	T9315	0.4	■	270	0.12	0.8	-	-	-	✓	255	0.12	0.8	-	-	-	-	
	T9325	0.4	■	205	0.18	0.8	■	120	0.16	0.8	✓	190	0.18	0.8	-	-	-	



Kesme hızı (vc), ilerleme (f) ve kesme derinliği (ap) için uygunluk ve başlangıç değerleri. Daha ileri hesaplamalar için İşleme Hesaplayıcısı uygulamasına başvurun.

Product	RE (mm)	P			M			K			N			S			H		
		vc (m/min)	f (mm/rev)	ap (mm)	vc (m/min)	f (mm/rev)	ap (mm)	vc (m/min)	f (mm/rev)	ap (mm)	vc (m/min)	f (mm/rev)	ap (mm)	vc (m/min)	f (mm/rev)	ap (mm)	vc (m/min)	f (mm/rev)	ap (mm)

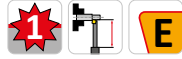

FM geometri, finiştan yarı kaba işleme, ve darbesizden hafif darbeli kesmeye kadar uygun.

TCMT 110208E-FM	T7325	0.8	195	0.17	0.8	150	0.15	0.8	-	-	-	-	-	-	-	-	-	-
	T8330	0.8	175	0.17	0.8	105	0.15	0.8	165	0.17	0.8	525	0.20	0.8	-	-	-	-
	T8430	0.8	200	0.17	0.8	110	0.15	0.8	165	0.17	0.8	555	0.20	0.8	-	-	-	-
	T9315	0.8	275	0.17	0.8	-	-	-	260	0.17	0.8	-	-	-	-	-	-	-
	T9325	0.8	250	0.17	0.8	150	0.15	0.8	235	0.17	0.8	-	-	-	-	-	-	-
TCMT 16T304E-FM	T7325	0.4	150	0.19	1.7	115	0.17	1.7	-	-	-	-	-	-	-	-	-	-
	T7335	0.4	145	0.19	1.7	110	0.17	1.7	-	-	-	-	-	-	-	-	-	-
	T8315	0.4	155	0.12	1.7	90	0.11	1.7	145	0.12	1.7	465	0.14	1.7	-	-	-	-
	T8330	0.4	150	0.12	1.7	90	0.11	1.7	140	0.12	1.7	450	0.14	1.7	-	-	-	-
	T8430	0.4	180	0.12	1.7	95	0.11	1.7	145	0.12	1.7	495	0.14	1.7	-	-	-	-
	T9315	0.4	250	0.12	1.7	-	-	-	235	0.12	1.7	-	-	-	-	-	-	-
	T9325	0.4	190	0.18	1.7	110	0.16	1.7	180	0.18	1.7	-	-	-	-	-	-	-
TCMT 16T308E-FM	T7325	0.8	180	0.17	1.7	140	0.15	1.7	-	-	-	-	-	-	-	-	-	-
	T7335	0.8	175	0.17	1.7	135	0.15	1.7	-	-	-	-	-	-	-	-	-	-
	T8315	0.8	170	0.17	1.7	100	0.15	1.7	160	0.17	1.7	510	0.20	1.7	-	-	-	-
	T8330	0.8	160	0.17	1.7	95	0.15	1.7	150	0.17	1.7	480	0.20	1.7	-	-	-	-
	T8430	0.8	185	0.17	1.7	100	0.15	1.7	150	0.17	1.7	510	0.20	1.7	-	-	-	-
	T9315	0.8	255	0.17	1.7	-	-	-	240	0.17	1.7	-	-	-	-	-	-	-
	T9325	0.8	230	0.17	1.7	135	0.15	1.7	215	0.17	1.7	-	-	-	-	-	-	-

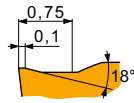

FM2 geometri, finiştan orta işleme kadar, ve darbesizden darbeli kesmeye kadar uygun.

TCMT 110204E-FM2	T8330	0.4	145	0.12	0.8	85	0.11	0.8	135	0.12	0.8	-	-	-	-	-	-
	T8430	0.4	180	0.12	0.8	95	0.11	0.8	145	0.12	0.8	-	-	-	-	-	-
	T9325	0.4	220	0.12	0.8	130	0.11	0.8	205	0.12	0.8	-	-	-	-	-	-
TCMT 110208E-FM2	T8330	0.8	155	0.17	0.8	90	0.15	0.8	145	0.17	0.8	-	-	-	-	-	-
	T8430	0.8	185	0.17	0.8	100	0.15	0.8	150	0.17	0.8	-	-	-	-	-	-
	T9325	0.8	225	0.17	0.8	135	0.15	0.8	210	0.17	0.8	-	-	-	-	-	-
	T9335	0.8	195	0.17	0.8	115	0.15	0.8	-	-	-	-	-	-	-	-	-
TCMT 16T308E-FM2	T7325	0.8	170	0.20	1.0	130	0.18	1.0	-	-	-	-	-	-	-	-	-
	T8330	0.8	145	0.20	1.0	85	0.18	1.0	135	0.20	1.0	-	-	-	-	-	-
	T8430	0.8	170	0.20	1.0	90	0.18	1.0	135	0.20	1.0	-	-	-	-	-	-
	T9325	0.8	205	0.20	1.0	120	0.18	1.0	190	0.20	1.0	-	-	-	-	-	-
	T9335	0.8	175	0.20	1.0	105	0.18	1.0	-	-	-	-	-	-	-	-	-

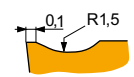

RF geometri, yarı kabadan kaba işleme kadar, ve darbesizden darbeli kesime kadar uygun.

TCMT 16T308E-RF	T9325	0.8	175	0.20	1.5	105	0.18	1.5	165	0.20	1.5	-	-	-	-	-	-
-----------------	-------	-----	-----	------	-----	-----	------	-----	-----	------	-----	---	---	---	---	---	---

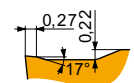

RM geometri, yarı kabadan kaba işleme kadar, ve darbesizden darbeli kesime kadar uygun.

TCMT 16T308E-RM	T5305	0.8	265	0.27	1.9	-	-	-	250	0.27	1.9	-	-	-	50	0.15	1.0	
	T5315	0.8	235	0.27	1.9	-	-	-	220	0.27	1.9	-	-	-	45	0.15	1.0	
	T7335	0.8	155	0.27	1.9	120	0.24	1.9	-	-	-	50	0.19	1.5	-	-	-	
	T8330	0.8	145	0.27	1.9	85	0.24	1.9	135	0.27	1.9	-	-	-	35	0.19	1.5	
	T8430	0.8	165	0.27	1.9	90	0.24	1.9	135	0.27	1.9	-	-	-	35	0.19	1.5	
	T9315	0.8	215	0.27	1.9	-	-	-	200	0.27	1.9	-	-	-	-	-	40	0.15
	T9325	0.8	195	0.27	1.9	115	0.24	1.9	185	0.27	1.9	-	-	-	40	0.19	1.5	



Kesme hızı (vc), ilerleme (f) ve kesme derinliği (ap) için uygunluk ve başlangıç değerleri. Daha ileri hesaplamalar için İşleme Hesaplayıcısı uygulamasına başvurun.

Product	RE (mm)	P			M			K			N			S			H		
		vc (m/min)	f (mm/rev)	ap (mm)	vc (m/min)	f (mm/rev)	ap (mm)	vc (m/min)	f (mm/rev)	ap (mm)	vc (m/min)	f (mm/rev)	ap (mm)	vc (m/min)	f (mm/rev)	ap (mm)	vc (m/min)	f (mm/rev)	ap (mm)

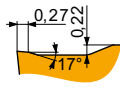

RM geometri, yarı kabadan kaba işleme kadar, ve darbesizden darbeli kesime kadar uygun.

TCMT 16T312E-RM	T5305	1.2	280	0.27	1.9	-	-	-	265	0.27	1.9	-	-	-	-	-	-	55	0.15	1.0
	T5315	1.2	250	0.27	1.9	-	-	-	235	0.27	1.9	-	-	-	-	-	-	50	0.15	1.0
	T8330	1.2	150	0.27	1.9	90	0.24	1.9	140	0.27	1.9	-	-	-	35	0.19	1.5	30	0.15	1.0
	T8430	1.2	170	0.27	1.9	90	0.24	1.9	135	0.27	1.9	-	-	-	35	0.19	1.5	25	0.15	1.0
	T9315	1.2	225	0.27	1.9	-	-	-	210	0.27	1.9	-	-	-	-	-	-	45	0.15	1.0
	T9325	1.2	205	0.27	1.9	120	0.24	1.9	190	0.27	1.9	-	-	-	45	0.19	1.5	-	-	-

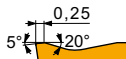

RM3 geometri, yarı kabadan kaba işleme kadar, ve darbesizden darbeli kesime kadar uygun.

TCMT 16T304E-RM3	T6310	0.4	110	0.25	2.0	75	0.25	2.0	85	0.25	2.0	-	-	-	-	-	-	20	0.15	1.0
	T7325	0.4	125	0.25	2.0	95	0.25	2.0	-	-	-	-	-	-	-	-	-	-	-	
	T8330	0.4	110	0.25	2.0	65	0.25	2.0	100	0.25	2.0	-	-	-	-	-	-	20	0.15	1.0
	T8430	0.4	120	0.25	2.0	65	0.25	2.0	95	0.25	2.0	-	-	-	-	-	-	20	0.15	1.0
	T9315	0.4	165	0.25	2.0	-	-	-	155	0.25	2.0	-	-	-	-	-	-	30	0.15	1.0
	T9325	0.4	145	0.25	2.0	85	0.25	2.0	135	0.25	2.0	-	-	-	-	-	-	-	-	
TCMT 16T308E-RM3	T6310	0.8	125	0.27	2.0	90	0.27	2.0	100	0.27	2.0	-	-	-	-	-	-	25	0.15	1.0
	T7325	0.8	145	0.27	2.0	110	0.27	2.0	-	-	-	-	-	-	-	-	-	-		
	T8330	0.8	125	0.27	2.0	75	0.27	2.0	115	0.27	2.0	-	-	-	-	-	-	25	0.15	1.0
	T8430	0.8	135	0.27	2.0	75	0.27	2.0	110	0.27	2.0	-	-	-	-	-	-	20	0.15	1.0
	T9315	0.8	185	0.27	2.0	-	-	-	175	0.27	2.0	-	-	-	-	-	-	35	0.15	1.0
	T9325	0.8	170	0.27	2.0	100	0.27	2.0	160	0.27	2.0	-	-	-	-	-	-	-		

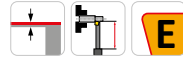
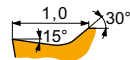

UR geometri, inceden finişe kadar işleme için, ve darbesiz ve hafif darbeli kesim.

TCMT 110204E-UR	T7325	0.4	135	0.19	0.8	105	0.17	0.8	-	-	-	-	-	-	-	-	-	-	-
	T8330	0.4	135	0.12	0.8	80	0.11	0.8	125	0.12	0.8	-	-	-	-	-	-	-	
	T8430	0.4	170	0.12	0.8	90	0.11	0.8	135	0.12	0.8	-	-	-	-	-	-	-	
	T9315	0.4	235	0.12	0.8	-	-	-	220	0.12	0.8	-	-	-	-	-	-	-	
	T9325	0.4	175	0.18	0.8	105	0.16	0.8	165	0.18	0.8	-	-	-	-	-	-	-	
TCMT 16T304E-UR	T7325	0.4	135	0.19	0.8	105	0.17	0.8	-	-	-	-	-	-	-	-	-	-	
	T8330	0.4	135	0.12	0.8	80	0.11	0.8	125	0.12	0.8	-	-	-	-	-	-	-	
	T8430	0.4	170	0.12	0.8	90	0.11	0.8	135	0.12	0.8	-	-	-	-	-	-	-	
	T9315	0.4	235	0.12	0.8	-	-	-	220	0.12	0.8	-	-	-	-	-	-	-	
	T9325	0.4	175	0.18	0.8	105	0.16	0.8	165	0.18	0.8	-	-	-	-	-	-	-	
	TT310	0.4	225	0.12	0.8	135	0.11	0.8	-	-	-	-	-	-	-	-	-	-	
TCMT 16T308E-UR	T5315	0.8	245	0.17	0.8	-	-	-	230	0.17	0.8	-	-	-	-	-	-	-	
	T7325	0.8	170	0.17	0.8	130	0.15	0.8	-	-	-	-	-	-	-	-	-		
	T8330	0.8	150	0.17	0.8	90	0.15	0.8	140	0.17	0.8	-	-	-	-	-	-		
	T8430	0.8	175	0.17	0.8	95	0.15	0.8	140	0.17	0.8	-	-	-	-	-	-		
	T9315	0.8	240	0.17	0.8	-	-	-	225	0.17	0.8	-	-	-	-	-	-	-	
	T9325	0.8	215	0.17	0.8	125	0.15	0.8	200	0.17	0.8	-	-	-	-	-	-		



TCMW

PRAMET

	IC	D1	L	S
	(mm)	(mm)	(mm)	(mm)
1102	6.350	2.80	11.00	2.38
16T3	9.525	4.40	16.50	3.97

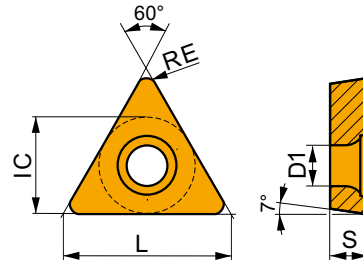

Kesme hızı (vc), ilerleme (f) ve kesme derinliği (ap) için uygunluk ve başlangıç değerleri. Daha ileri hesaplamalar için İşleme Hesaplayıcısı uygulamasına başvurun.

Product	RE	P			M			K			N			S			H		
		vc	f	ap	vc	f	ap	vc	f	ap	vc	f	ap	vc	f	ap	vc	f	ap
	(mm)	(m/min)	(mm/rev)	(mm)	(m/min)	(mm/rev)	(mm)	(m/min)	(mm/rev)	(mm)	(m/min)	(mm/rev)	(mm)	(m/min)	(mm/rev)	(mm)	(m/min)	(mm/rev)	(mm)

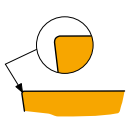

İnce finişten yarı kaba işleme kadar ve darbesizden hafif darbeli kesmeye kadar uygun.

TCMW 110204	T5305	0.4	-	-	-	-	-	-	200	0.10	1.2	-	-	-	-	-	-	40	0.15	1.0
	T5315	0.4	-	-	-	-	-	-	180	0.10	1.2	-	-	-	-	-	-	35	0.15	1.0
TCMW 16T304	T5305	0.4	-	-	-	-	-	-	195	0.10	1.5	-	-	-	-	-	-	40	0.15	1.0
	T5315	0.4	-	-	-	-	-	-	175	0.10	1.5	-	-	-	-	-	-	35	0.15	1.0
	T6310	0.4	-	-	-	-	-	-	85	0.10	1.5	-	-	-	-	-	-	20	0.15	1.0
TCMW 16T308	T5305	0.8	-	-	-	-	-	-	190	0.18	1.5	-	-	-	-	-	-	40	0.15	1.0
	T5315	0.8	-	-	-	-	-	-	165	0.18	1.5	-	-	-	-	-	-	35	0.15	1.0
	T6310	0.8	-	-	-	-	-	-	85	0.18	1.5	-	-	-	-	-	-	20	0.15	1.0

TCGW CBN

PRAMET

	IC	D1	L	S
	(mm)	(mm)	(mm)	(mm)
1102	6.350	2.90	11.00	2.38

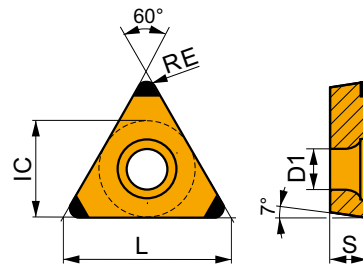

Kesme hızı (vc), ilerleme (f) ve kesme derinliği (ap) için uygunluk ve başlangıç değerleri. Daha ileri hesaplamalar için İşleme Hesaplayıcısı uygulamasına başvurun.

Product	RE	P			M			K			N			S			H		
		vc	f	ap	vc	f	ap	vc	f	ap	vc	f	ap	vc	f	ap	vc	f	ap
	(mm)	(m/min)	(mm/rev)	(mm)	(m/min)	(mm/rev)	(mm)	(m/min)	(mm/rev)	(mm)	(m/min)	(mm/rev)	(mm)	(m/min)	(mm/rev)	(mm)	(m/min)	(mm/rev)	(mm)

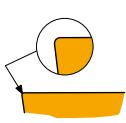

Finiş işleme ve darbesiz kesme için.

TCGW 110204E-C	TB310	0.4	-	-	-	-	-	-	390	0.10	0.4	-	-	-	100	0.07	0.3	80	0.15	1.0
----------------	-------	-----	---	---	---	---	---	---	-----	------	-----	---	---	---	-----	------	-----	----	------	-----

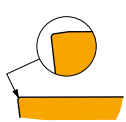

Finiş işleme ve darbesiz kesme için.

TCGW 110204S01020C	TB310	0.4	-	-	-	-	-	-	390	0.10	0.4	-	-	-	100	0.07	0.3	80	0.15	1.0
TCGW 110208S01020C	TB310	0.8	-	-	-	-	-	-	400	0.15	0.6	-	-	-	105	0.11	0.5	85	0.15	1.0



STFC(RL) EXT



PRAMET

S



TC.. Uç için Vida Sıklımal 91° (Alın) Açılı Dış Kater

Vida sıklımal Sađ/Sol 91° dıř kater. Pozitif TC.. 11-16 uçlarla alın ve pah ternalama için uygundur. 16x16-25x25mm řaft ölçülerinde bulunur. Gövde uzun takım ömrü için iřlem görmüřtür.

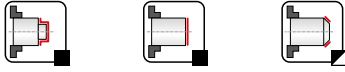
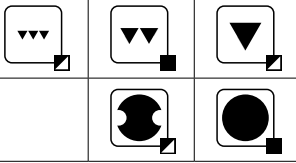
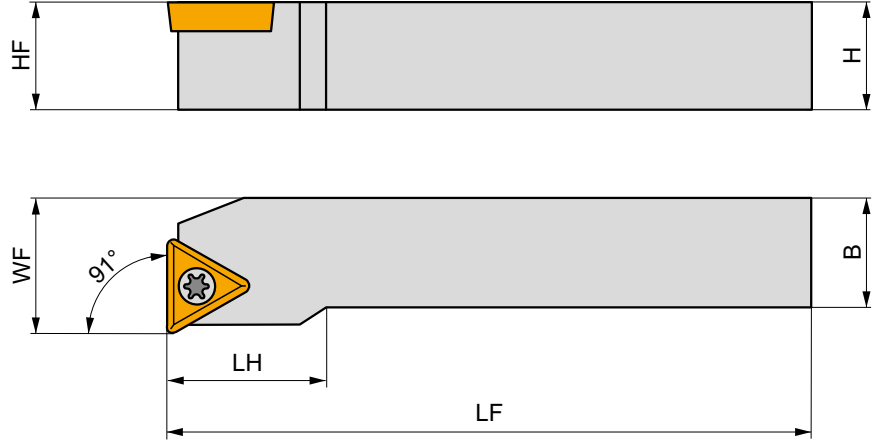
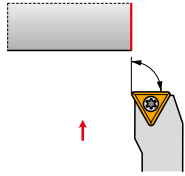

Product	H	B	HF	WF	LF	LH	LAMS	GAMO	kg	GI016	GI056	S01
	(mm)	(mm)	(mm)	(mm)	(mm)	(mm)	(°)	(°)				
R STFCR 1616 H 11	16	16	16	20	100	18	0	0	0.20	GI056	S01	
STFCR 2020 K 16-M-A	20	20	20	25	125	25	0	0	0.40	GI016	ST10	
STFCR 2525 M 16-M-A	25	25	25	32	150	25	0	0	0.76	GI016	ST10	
L STFCL 1616 H 11	16	16	16	20	100	18	0	0	0.22	GI056	S01	
STFCL 2020 K 16-M-A	20	20	20	25	125	25	0	0	0.40	GI016	ST10	
STFCL 2525 M 16-M-A	25	25	25	32	150	25	0	0	0.75	GI016	ST10	



GI016

TC.. 16T3..

GI056

TC.. 1102..



S01

US 2506-T07P

0.9

M 2.5

6.3

-

-

FLAGT07P

-

ST10

US 3510-T15P

3.0

M 3.5

10.6

STN 160308

MS 3510

FLAGT15P

HXK 3.5



STFC(RL)-A EXT



PRAMET

S



TC.. Uç için Vida Sıkmalı 90° (Alın) Açılı Dış Kater

Vida sıkmalı Sağ/Sol dış kater. Pozitif TC.. 11 uçlarla alın ve pah tornalama için uygundur. 20x20mm şaft ölçülerinde bulunur. Gövde uzun takım ömrü için işlem görmüştür.

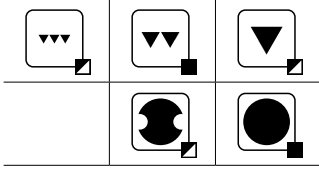
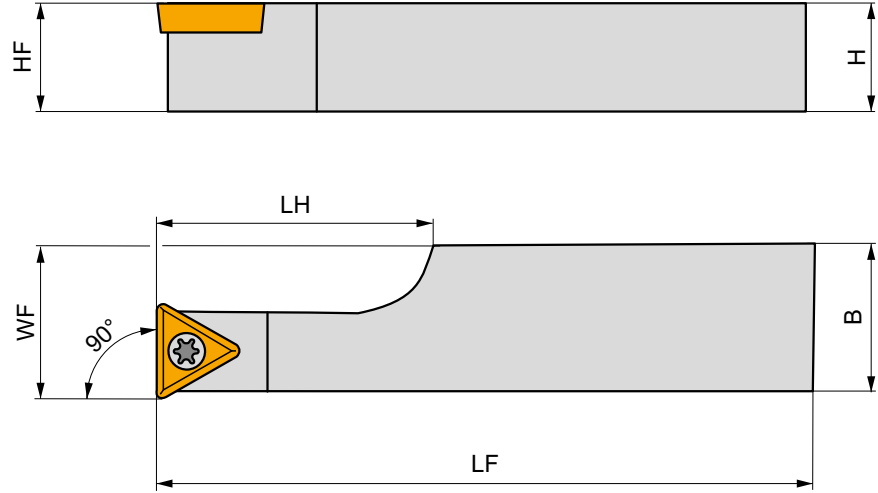
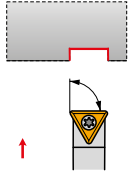

Product	H	B	HF	WF	LF	LH	LAMS	GAMO	kg	GI056	ST21
	(mm)	(mm)	(mm)	(mm)	(mm)	(mm)	(°)	(°)			
R STFCR 2020 K 11-A	20	20	20	25	125	21.3	0	0	0.52	GI056	ST21
L STFCL 2020 K 11-A	20	20	20	25	125	21.3	0	0	0.36	GI056	ST21



GI056



TC.. 1102..



ST21



5513 020-03



0.8



M 2.5



6.5



PT-8001



STJC(RL) EXT

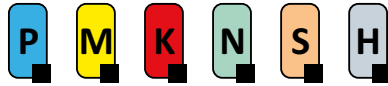

PRAMET

S



TC.. Uç için Vida Sıklı 93° Açılı Dış Kater

Vida sıklı Sađ/Sol dış kater. Pozitif TC.. 11-16 uçlarla çap, konik ve pah tornalama için uygundur. 16x16-25x25mm şaft ölçülerinde bulunur. Gövde uzun takım ömrü için işlem görmüştür.

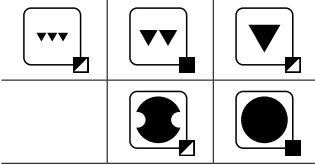
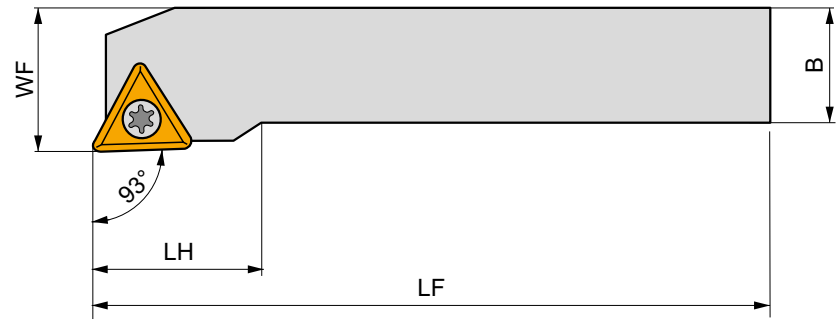
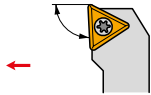

Product	H	B	HF	WF	LF	LH	LAMS	GAMO	kg	GI	ST	
	(mm)	(mm)	(mm)	(mm)	(mm)	(mm)	(°)	(°)				
R	STJCR 1616 H 11	16	16	16	20	100	18	0	0	0.23	GI056	S01
	STJCR 2020 K 16-M-A	20	20	20	25	125	25	0	0	0.44	GI016	ST10
	STJCR 2525 M 16-M-A	25	25	25	32	150	25	0	0	0.76	GI016	ST10
L	STJCL 1616 H 11	16	16	16	20	100	18	0	0	0.22	GI056	S01
	STJCL 2020 K 16-M-A	20	20	20	25	125	25	0	0	0.43	GI016	ST10
	STJCL 2525 M 16-M-A	25	25	25	32	150	25	0	0	0.75	GI016	ST10



GI016
GI056

TC.. 16T3..
TC.. 1102..



S01
ST10

US 2506-T07P
US 3510-T15P

0.9
3.0

M 2.5
M 3.5

6.3
10.6

-
STN 160308

-
MS 3510

FLAGT07P
FLAGT15P

-
HXK 3.5



STFC(RL) INT

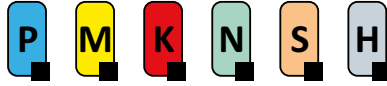

PRAMET

S



TC.. Uç için Vida Sıkmalı 91° Açılı Delik Kateri

Vida sıkmalı Sağ/Sol 91° içten su vermeli delik kateri. Pozitif TC.. 07-16 uçlarla minimum Ø8.5mm çap, konik, ve pah tornalama için uygundur. Ø6-32mm şaft ölçülerinde bulunur. Gövde uzun takım ömrü için işlem görmüştür.

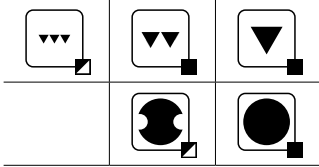
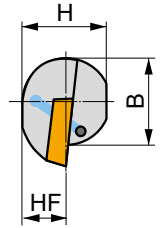
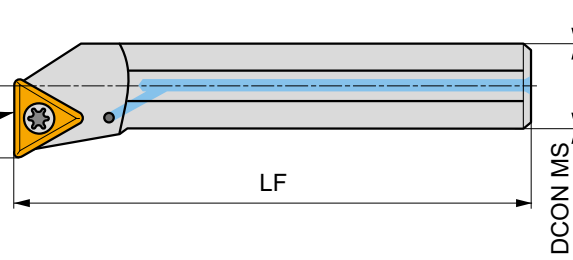
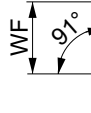
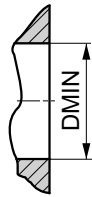
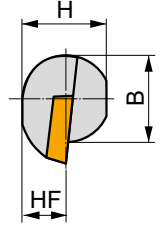
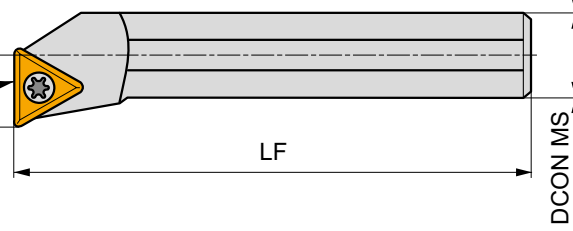
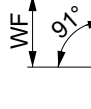
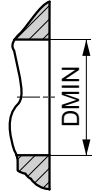
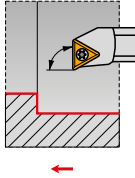

Product	DCON MS	DMIN	WF	H	B	LF	LAMS	GAMO		kg		
	(mm)	(mm)	(mm)	(mm)	(mm)	(mm)	(°)	(°)				
R A06F-STFCR 06	6	8.5	4.5	5	-	80	-12	0	✓	0.03	GI217	ST12
A08H-STFCR 06	8	11	5.9	7	-	100	-10	0	✓	0.04	GI217	ST13
A10K-STFCR 09	10	13	7	9	-	125	-9	0	✓	0.06	GI218	ST14
A12M-STFCR 09	12	16	9	11	-	150	-6.5	0	✓	0.12	GI218	ST14
S10H-STFCR 11	10	13	7	9	9.5	100	-10	0	-	0.08	GI056	S02
A12M-STFCR 11	12	16	9	11	11.5	150	-10	0	✓	0.14	GI056	S01
S12K-STFCR 11	12	16	9	11	11.5	125	-7	0	-	0.13	GI056	S01
A16R-STFCR 11	16	20	11	14.5	15	200	-7	0	✓	0.27	GI056	S01
S16M-STFCR 11	16	20	11	14.5	15	150	-7	0	-	0.24	GI056	S01
A20S-STFCR 11	20	25	13	18	18.5	250	-7	0	✓	0.54	GI056	S01
S20Q-STFCR 11	20	25	13	18	18.5	180	-7	0	-	0.40	GI056	S01
A25R-STFCR 16	25	32	17	23	23	200	-3	0	✓	0.67	GI016	S08
S25T-STFCR 16	25	32	17	23	23	300	-3	0	-	1.15	GI016	S08
A32S-STFCR 16	32	40	22	30	30	250	-10	0	✓	1.36	GI016	ST10
S32U-STFCR 16-A	32	40	22	30	30	350	-10	0	-	2.10	GI016	ST10
L A06F-STFCL 06	6	8.5	4.5	5	-	80	-12	0	✓	0.03	GI217	ST12
A08H-STFCL 06	8	11	5.9	7	-	100	-10	0	✓	0.05	GI217	ST13
A10K-STFCL 09	10	13	7	9	-	125	-9	0	✓	0.06	GI218	ST14
A12M-STFCL 09	12	16	9	11	-	150	-6.5	0	✓	0.03	GI218	ST14
S10H-STFCL 11	10	13	7	9	9.5	100	-10	0	-	0.06	GI056	S02
A12M-STFCL 11	12	16	9	11	11.5	150	-10	0	✓	0.12	GI056	S01
S12K-STFCL 11	12	16	9	11	11.5	125	-7	0	-	0.12	GI056	S01
A16R-STFCL 11	16	20	11	14.5	15	200	-7	0	✓	0.00	GI056	S01
S16M-STFCL 11	16	20	11	14.5	15	150	-7	0	-	0.25	GI056	S01
A20S-STFCL 11	20	25	13	18	18.5	250	-7	0	✓	0.00	GI056	S01
S20Q-STFCL 11	20	25	13	18	18.5	180	-7	0	-	0.42	GI056	S01
A25R-STFCL 16	25	32	17	23	23	200	-3	0	✓	0.00	GI016	S08



Product	DCON MS	DMIN	WF	H	B	LF	LAMS	GAMO				
	(mm)	(mm)	(mm)	(mm)	(mm)	(mm)	(°)	(°)				
L S25T-STFCL 16	25	32	17	23	23	300	-3	0	-	1.15	G1016	S08
A32S-STFCL 16	32	40	22	30	30	250	-10	0	✓	1.36	G1016	ST10
S32U-STFCL 16-A	32	40	22	30	30	350	-10	0	-	2.06	G1016	ST10



G1016	TC.. 16T3..
G1056	TC.. 1102..
G1217	TC.. 06T1..
G1218	TC.. 0902..

S01	US 2506-T07P	0.9	M 2.5	6.3	-	-	FLAG T07P	-	-
S02	US 2505-T07P	0.9	M 2.5	5.2	-	-	FLAG T07P	-	-
S08	US 3510-T15P	3.0	M 3.5	10.6	-	-	FLAG T15P	-	-
ST10	US 3510-T15P	3.0	M 3.5	10.6	STN 160308	MS 3510	FLAG T15P	HXK 3.5	-
ST12	5513 020-28	0.6	M 2	4.2	-	-	-	-	PT-8000
ST13	5513 020-27	0.6	M 2	4.9	-	-	-	-	PT-8000
ST14	5513 020-05	0.8	M 2.2	6.4	-	-	-	-	PT-8001



STFC(RL)-E INT



PRAMET

S



TC.. Uç için Vida Sıkmalı 91° Açılı Karbür Delik Kateri

Vida sıkmalı Sağ/Sol 91° içten su vermeli karbür delik kateri. Pozitif TC.. 06-11 uçlarla minimum Ø8.5mm çap, ve 32°ye kadar çap, konik ve pah tornalama için uygundur. Ø6-16mm shaft ölçülerinde bulunur. Gövde uzun takım ömrü için işlem görmüştür. Delik boyu > 3xD

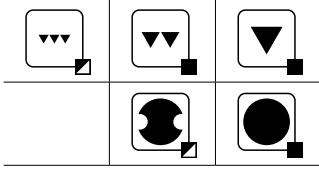
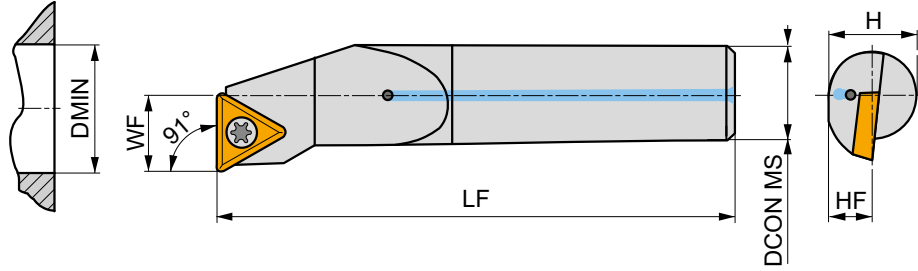
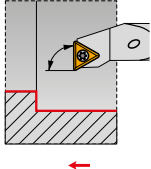

Product	DCON MS	DMIN	WF	H	HF	LF	LAMS	GAMO	✓	kg	GI217	ST22	
	(mm)	(mm)	(mm)	(mm)	(mm)	(mm)	(°)	(°)					
R	E06H-STFCR 06-R	6	8.5	4.5	6	3	100	-10	0	✓	0.05	GI217	ST22
	E08K-STFCR 06-R	8	11	5.9	8	4	125	-10	0	✓	0.09	GI217	ST23
	E10M-STFCR 09-R	10	13	7	10	5	150	-8	0	✓	0.15	GI218	ST24
	E12Q-STFCR 09-R	12	16	9	12	6	180	-6	0	✓	0.26	GI218	ST24
	E16R-STFCR 11-R	16	20	11	16	8	200	-5	0	✓	0.48	GI056	ST21
L	E06H-STFCL 06-R	6	8.5	4.5	6	3	100	-10	0	✓	0.05	GI217	ST22
	E08K-STFCL 06-R	8	11	5.9	8	4	125	-10	0	✓	0.09	GI217	ST23
	E10M-STFCL 09-R	10	13	7	10	5	150	-8	0	✓	0.15	GI218	ST24
	E12Q-STFCL 09-R	12	16	9	12	6	180	-6	0	✓	0.26	GI218	ST24
	E16R-STFCL 11-R	16	20	11	16	8	200	-5	0	✓	0.48	GI056	ST21



GI056	TC.. 1102..
GI217	TC.. 06T1..
GI218	TC.. 0902..



ST21	5513 020-03	0.8	M 2.5	6.5	PT-8001
ST22	5513 020-28	0.6	M 2	4.2	PT-8000
ST23	5513 020-27	0.6	M 2	4.9	PT-8000
ST24	5513 020-05	0.8	M 2.2	6.4	PT-8001



TP

09/ 11/ 16

KARBÜR UÇLAR

TPGX



162

TPMR



163

TPUN



164

CER UÇLAR

TPGN CER



164



TPGX



	IC	D1	L	S
	(mm)	(mm)	(mm)	(mm)
0902	5.560	2.50	9.60	2.38
1102	6.350	2.80	11.00	2.38
16T3	9.525	4.40	16.50	3.97

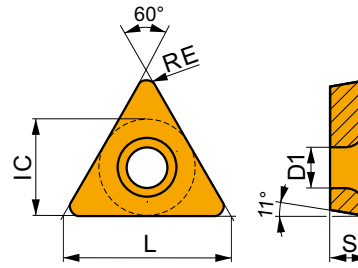

Kesme hızı (vc), ilerleme (f) ve kesme derinliği (ap) için uygunluk ve başlangıç değerleri. Daha ileri hesaplamalar için İşleme Hesaplayıcısı uygulamasına başvurun.

Product	RE	P			M			K			N			S			H		
		vc	f	ap	vc	f	ap	vc	f	ap	vc	f	ap	vc	f	ap	vc	f	ap
	(mm)	(m/min)	(mm/rev)	(mm)	(m/min)	(mm/rev)	(mm)	(m/min)	(mm/rev)	(mm)	(m/min)	(mm/rev)	(mm)	(m/min)	(mm/rev)	(mm)	(m/min)	(mm/rev)	(mm)

			F	FR-JQ sağ kesme yönlü geometri, ince finiş işleme için çok pozitif tasarım, darbesiz kesime uygun.																
TPGX 110204FR-JQ	TT010	0.4	■ 295	0.06	0.5	■ 175	0.05	0.5	■ -	-	-	■ -	-	-	■ -	-	-	■ -	-	-
			F	FR-JQ sol kesme yönlü geometri, ince finiş işleme için çok pozitif tasarım, darbesiz kesime uygun.																
TPGX 090204FL-JQ	TT010	0.4	■ 295	0.06	0.5	■ 175	0.05	0.5	■ -	-	-	■ -	-	-	■ -	-	-	■ -	-	-
TPGX 110204FL-JQ	TT010	0.4	■ 295	0.06	0.5	■ 175	0.05	0.5	■ -	-	-	■ -	-	-	■ -	-	-	■ -	-	-
			F	FL-JR sol kesme yönlü geometri, ince finiş işleme için çok pozitif tasarım, darbesiz kesime uygun.																
TPGX 16T304FL-JR	TT010	0.4	■ 295	0.06	0.5	■ 175	0.05	0.5	■ -	-	-	■ -	-	-	■ -	-	-	■ -	-	-
			F	FR-JR sağ kesme yönlü geometri, ince finiş işleme için çok pozitif tasarım, darbesiz kesime uygun.																
TPGX 090202FR-JZ	TT010	0.2	■ 280	0.06	0.5	■ 165	0.05	0.5	■ -	-	-	■ -	-	-	■ -	-	-	■ -	-	-
			F	FL-JR sol kesme yönlü geometri, ince finiş işleme için çok pozitif tasarım, darbesiz kesime uygun.																
TPGX 090202FL-JZ	TT010	0.2	■ 280	0.06	0.5	■ 165	0.05	0.5	■ -	-	-	■ -	-	-	■ -	-	-	■ -	-	-



TPMR



	IC (mm)	L (mm)	S (mm)
1103	6.350	11.00	3.18
1603	9.525	16.50	3.18

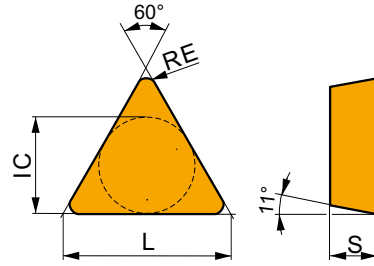

Kesme hızı (vc), ilerleme (f) ve kesme derinliği (ap) için uygunluk ve başlangıç değerleri. Daha ileri hesaplamalar için İşleme Hesaplayıcısı uygulamasına başvurun.

Product	RE (mm)	P			M			K			N			S			H		
		vc (m/min)	f (mm/rev)	ap (mm)	vc (m/min)	f (mm/rev)	ap (mm)	vc (m/min)	f (mm/rev)	ap (mm)	vc (m/min)	f (mm/rev)	ap (mm)	vc (m/min)	f (mm/rev)	ap (mm)	vc (m/min)	f (mm/rev)	ap (mm)

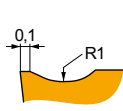

Geometri 46, inceden finiş işlemeye kadar, ve darbesizden darbeleri kesime kadar uygun.

TPMR 110304E-46	6640	0.4	140	0.15	1.0	80	0.14	1.0	130	0.15	1.0	-	-	-	-	-	-	-
	T9325	0.4	175	0.15	1.0	105	0.15	1.0	165	0.15	1.0	-	-	-	-	-	-	-
	T9335	0.4	150	0.15	1.0	90	0.15	1.0	-	-	-	-	-	-	-	-	-	-
TPMR 110308E-46	6640	0.8	170	0.15	1.0	100	0.14	1.0	160	0.15	1.0	-	-	-	-	-	-	-
	T9325	0.8	205	0.15	1.0	120	0.15	1.0	190	0.15	1.0	-	-	-	-	-	-	-
	T9335	0.8	180	0.15	1.0	105	0.15	1.0	-	-	-	-	-	-	-	-	-	-

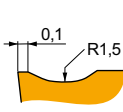

Geometri 47, finişten yarı kaba işlemeye kadar, ve darbesizden darbeleri kesime kadar uygun.

TPMR 160304E-47	6640	0.4	120	0.20	1.5	70	0.18	1.5	110	0.20	1.5	-	-	-	-	-	-	-
	T9325	0.4	150	0.20	1.5	90	0.18	1.5	140	0.20	1.5	-	-	-	-	-	-	-
	T9335	0.4	125	0.20	1.5	75	0.18	1.5	-	-	-	-	-	-	-	-	-	-
TPMR 160308E-47	6640	0.8	140	0.20	1.5	80	0.18	1.5	130	0.20	1.5	-	-	-	-	-	-	-
	T9325	0.8	175	0.20	1.5	105	0.18	1.5	165	0.20	1.5	-	-	-	-	-	-	-
	T9335	0.8	150	0.20	1.5	90	0.18	1.5	-	-	-	-	-	-	-	-	-	-
TPMR 160312E-47	T9325	1.2	185	0.20	1.5	110	0.18	1.5	175	0.20	1.5	-	-	-	-	-	-	-
	T9335	1.2	160	0.20	1.5	95	0.18	1.5	-	-	-	-	-	-	-	-	-	-

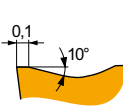

Geometri 61, orta kesme hızları ve talaş derinliklerinde finiş işleme, ve darbesizden darbeleri kesime kadar uygun.

TPMR 160308E-61	T9325	0.8	135	0.35	1.8	80	0.32	1.8	125	0.35	1.8	-	-	-	-	-	-	-
	T9335	0.8	120	0.35	1.8	70	0.32	1.8	-	-	-	-	-	-	-	-	-	-

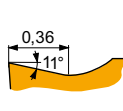

PF2 geometri, inceden finiş işlemeye kadar, ve darbesiz kesim için uygun.

TPMR 110304-PF2	TT010	0.4	255	0.10	0.5	150	0.10	0.5	-	-	-	-	-	-	-	-	-	-
TPMR 160304-PF2	TT010	0.4	255	0.10	0.5	150	0.10	0.5	-	-	-	-	-	-	-	-	-	-



TPUN



	IC (mm)	L (mm)	S (mm)
1103	6.350	11.00	3.18
1603	9.525	16.50	3.18
2204	12.700	22.00	4.76
2706	15.875	27.50	6.35
3306	19.050	33.00	6.35

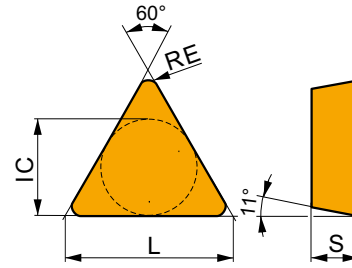

Kesme hızı (vc), ilerleme (f) ve kesme derinliği (ap) için uygunluk ve başlangıç değerleri. Daha ileri hesaplamalar için İşleme Hesaplayıcısı uygulamasına başvurun.

Product	RE (mm)	P			M			K			N			S			H		
		vc (m/min)	f (mm/rev)	ap (mm)	vc (m/min)	f (mm/rev)	ap (mm)	vc (m/min)	f (mm/rev)	ap (mm)	vc (m/min)	f (mm/rev)	ap (mm)	vc (m/min)	f (mm/rev)	ap (mm)	vc (m/min)	f (mm/rev)	ap (mm)

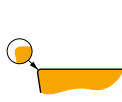

İnce finişten yarı kaba işleme kadar ve darbesizden hafif darbeli kesmeye kadar uygun.

TPUN 110304	6640	0.4	✓	135	0.10	1.2	–	–	–	■	125	0.10	1.2	–	–	–	–	–	–
TPUN 110308	6640	0.8	✓	125	0.18	1.2	–	–	–	■	115	0.18	1.2	–	–	–	–	–	–
TPUN 160304	6640	0.4	✓	135	0.10	1.5	–	–	–	■	125	0.10	1.5	–	–	–	–	–	–
TPUN 160308	6640	0.8	✓	125	0.18	1.5	–	–	–	■	115	0.18	1.5	–	–	–	–	–	–
TPUN 160312	6640	1.2	✓	125	0.20	1.5	–	–	–	■	115	0.20	1.5	–	–	–	–	–	–
TPUN 220408	6640	0.8	✓	120	0.18	2.0	–	–	–	■	110	0.18	2.0	–	–	–	–	–	–
TPUN 220412	6640	1.2	✓	120	0.20	2.0	–	–	–	■	110	0.20	2.0	–	–	–	–	–	–

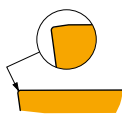

İnce finişten yarı kaba işleme kadar ve darbesizden hafif darbeli kesmeye kadar uygun.

TPUN 270616S	6640	1.6	✓	60	0.30	7.0	–	–	–	■	55	0.30	7.0	–	–	–	–	–	–
TPUN 330620S	6640	2.0	✓	65	0.30	5.0	–	–	–	■	60	0.30	5.0	–	–	–	–	–	–

TPGN CER



	IC (mm)	L (mm)	S (mm)
1103	6.350	11.00	3.18
1603	9.525	16.50	3.18

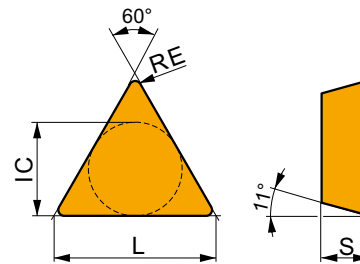

Kesme hızı (vc), ilerleme (f) ve kesme derinliği (ap) için uygunluk ve başlangıç değerleri. Daha ileri hesaplamalar için İşleme Hesaplayıcısı uygulamasına başvurun.

Product	RE (mm)	P			M			K			N			S			H		
		vc (m/min)	f (mm/rev)	ap (mm)	vc (m/min)	f (mm/rev)	ap (mm)	vc (m/min)	f (mm/rev)	ap (mm)	vc (m/min)	f (mm/rev)	ap (mm)	vc (m/min)	f (mm/rev)	ap (mm)	vc (m/min)	f (mm/rev)	ap (mm)



Yüksek hızlı işleme ve darbesiz kesme için.

TPGN 110304 T01020	TC100	0.4	–	–	–	–	–	–	–	■	460	0.10	1.5	–	–	–	–	–	–
TPGN 110308 T01020	TC100	0.8	–	–	–	–	–	–	–	■	425	0.20	1.5	–	–	–	–	–	–



Kesme hızı (vc), ilerleme (f) ve kesme derinliği (ap) için uygunluk ve başlangıç değerleri. Daha ileri hesaplamalar için İşleme Hesaplayıcısı uygulamasına başvurun.

Product	RE (mm)	P			M			K			N			S			H		
		vc (m/min)	f (mm/rev)	ap (mm)	vc (m/min)	f (mm/rev)	ap (mm)	vc (m/min)	f (mm/rev)	ap (mm)	vc (m/min)	f (mm/rev)	ap (mm)	vc (m/min)	f (mm/rev)	ap (mm)	vc (m/min)	f (mm/rev)	ap (mm)

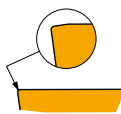

Yüksek hızlı işleme ve darbesiz kesme için.

TPGN 160304 T01020	TC100	0.4	-	-	-	-	-	-	-	460	0.10	1.5	-	-	-	-	-	-	-
TPGN 160308 T01020	TC100	0.8	-	-	-	-	-	-	-	425	0.20	1.5	-	-	-	-	-	-	-
TPGN 160312 T01020	TC100	1.2	-	-	-	-	-	-	-	450	0.20	1.5	-	-	-	-	-	-	-



VB

11/ 16

KARBÜR UÇLAR

VBMT



168

KARBÜR UÇLAR

VBGW CBN



171

DOĞRU BOYUTLA EŞLEŞTİRİN (örnek)

Kesici uç

VBMT 160408E-FM

Takım Tutucu

SVHCR 2020 K 16-M-A

ISO TORNALAMA - DIŞ















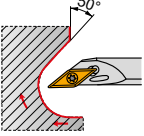
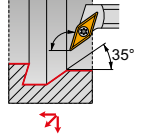
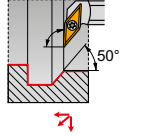
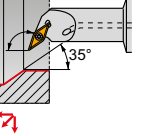





<p>SVHB(C)(RL) EXT</p> <p>107°30'</p> <p>VB, VC..</p> <p>11 16</p> <p>16x16 25x25</p> <p>172</p> <p>168 – 171 186 – 192</p>	<p>SVJB(C)(RL) EXT</p> <p>93°</p> <p>VB, VC..</p> <p>11 13 16</p> <p>12x12 32x25</p> <p>173</p> <p>168 – 171 186 – 192</p>	<p>SVPB(C)(RL) EXT</p> <p>117°30'</p> <p>VB, VC..</p> <p>11 16</p> <p>16x16 32x25</p> <p>174</p> <p>168 – 171 186 – 192</p>	<p>SVVB(C)N EXT</p> <p>72°30'</p> <p>VB, VC..</p> <p>11 13 16</p> <p>12x12 32x25</p> <p>175</p> <p>168 – 171 186 – 192</p>
<p>SVXB(C)(RL) EXT</p> <p>98°</p> <p>VB, VC..</p> <p>11 13 16</p> <p>12x12 32x25</p> <p>176</p> <p>168 – 171 186 – 192</p>	<p>C.-SVHB(RL) EXT NEW</p> <p>107°30'</p> <p>VB, VC..</p> <p>16</p> <p>C4 C6</p> <p>177</p> <p>168 – 171 186 – 192</p>	<p>C.-SVJB(RL) EXT NEW</p> <p>93°</p> <p>VB, VC..</p> <p>11 16</p> <p>C3 C6</p> <p>178</p> <p>168 – 171 186 – 192</p>	<p>C.-SVVB(N) EXT NEW</p> <p>72°30'</p> <p>VB, VC..</p> <p>16</p> <p>C4 C6</p> <p>179</p> <p>168 – 171 186 – 192</p>



VB

11/ 16

ISO TORNALAMA - İÇ

SVJB(RL) INT		SVQB(C)(RL) INT		SVUB(C)(RL) INT		C.-SVQB(C)(RL) INT NEW	
93°	VB, VC..  11	107°30'	VB, VC..  11 13 16	93°	VB, VC..  11 13 16	108°	VB, VC..  16
							
 $\frac{25}{32}$		 $\frac{20}{50}$		 $\frac{20}{50}$		 33	
 180	 168 – 171  186 – 192	 181	 168 – 171  186 – 192	 182	 168 – 171  186 – 192	 183	 168 – 171  186 – 192



VBMT



	IC	D1	L	S
	(mm)	(mm)	(mm)	(mm)
1102	6.350	2.80	11.10	2.38
1103	6.350	2.80	11.10	3.18
1604	9.525	4.40	16.60	4.76

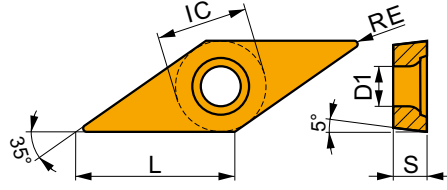

Kesme hızı (vc), ilerleme (f) ve kesme derinliği (ap) için uygunluk ve başlangıç değerleri. Daha ileri hesaplamalar için İşleme Hesaplayıcısı uygulamasına başvurun.

Product	RE (mm)	P			M			K			N			S			H		
		vc (m/min)	f (mm/rev)	ap (mm)	vc (m/min)	f (mm/rev)	ap (mm)	vc (m/min)	f (mm/rev)	ap (mm)	vc (m/min)	f (mm/rev)	ap (mm)	vc (m/min)	f (mm/rev)	ap (mm)	vc (m/min)	f (mm/rev)	ap (mm)

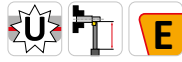
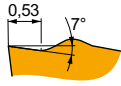

FF2 geometri, ince-finişten finişe işlemeye kadar için çok pozitif tasarım, darbesizden hafif darbeli işlemeye kadar uygun.

VBMT 160404E-FF2	T7325	0.4	145	0.12	0.8	-	-	-	-	-	-	-	-	-	-	-	-	-
	T8330	0.4	125	0.12	0.8	-	-	-	115	0.12	0.8	-	-	-	-	-	-	-
	T8430	0.4	150	0.12	0.8	-	-	-	125	0.12	0.8	-	-	-	-	-	-	-
	T9315	0.4	215	0.12	0.8	-	-	-	200	0.12	0.8	-	-	-	-	-	-	-
	T9325	0.4	190	0.12	0.8	-	-	-	180	0.12	0.8	-	-	-	-	-	-	-
	T9335	0.4	160	0.12	0.8	-	-	-	-	-	-	-	-	-	-	-	-	-

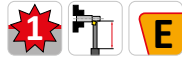

FM geometri, finişten yarı kaba işlemeye, ve darbesizden hafif darbeli kesmeye kadar uygun.

VBMT 110302E-FM	T7325	0.2	160	0.10	0.8	120	0.09	0.8	-	-	-	-	-	-	-	-	-
	T8315	0.2	145	0.10	0.8	85	0.09	0.8	135	0.10	0.8	435	0.12	0.8	-	-	-
	T8330	0.2	135	0.10	0.8	80	0.09	0.8	125	0.10	0.8	405	0.12	0.8	-	-	-
	T8430	0.2	170	0.10	0.8	90	0.09	0.8	135	0.10	0.8	465	0.12	0.8	-	-	-
	T9325	0.2	210	0.10	0.8	125	0.09	0.8	195	0.10	0.8	-	-	-	-	-	-
	T9335	0.2	180	0.10	0.8	110	0.09	0.8	-	-	-	-	-	-	-	-	-
VBMT 110304E-FM	T7325	0.4	140	0.19	0.8	105	0.17	0.8	-	-	-	-	-	-	-	-	-
	T7335	0.4	135	0.19	0.8	105	0.17	0.8	-	-	-	-	-	-	-	-	-
	T8315	0.4	145	0.12	0.8	85	0.11	0.8	135	0.12	0.8	435	0.14	0.8	-	-	-
	T8330	0.4	140	0.12	0.8	80	0.11	0.8	130	0.12	0.8	420	0.14	0.8	-	-	-
	T8430	0.4	170	0.12	0.8	90	0.11	0.8	135	0.12	0.8	465	0.14	0.8	-	-	-
	T9315	0.4	235	0.12	0.8	-	-	-	220	0.12	0.8	-	-	-	-	-	-
VBMT 110308E-FM	T7325	0.8	170	0.17	0.8	130	0.15	0.8	-	-	-	-	-	-	-	-	-
	T8330	0.8	150	0.17	0.8	90	0.15	0.8	140	0.17	0.8	450	0.20	0.8	-	-	-
	T8430	0.8	175	0.17	0.8	95	0.15	0.8	140	0.17	0.8	480	0.20	0.8	-	-	-
	T9315	0.8	240	0.17	0.8	-	-	-	225	0.17	0.8	-	-	-	-	-	-
	T9325	0.8	215	0.17	0.8	125	0.15	0.8	200	0.17	0.8	-	-	-	-	-	-
	T9335	0.8	180	0.17	0.8	110	0.15	0.8	-	-	-	-	-	-	-	-	-
VBMT 160402E-FM	T7325	0.2	150	0.10	1.2	115	0.09	1.2	-	-	-	-	-	-	-	-	-
	T8330	0.2	130	0.10	1.2	75	0.09	1.2	120	0.10	1.2	390	0.12	1.2	-	-	-
	T8430	0.2	165	0.10	1.2	90	0.09	1.2	135	0.10	1.2	450	0.12	1.2	-	-	-
	T9315	0.2	230	0.10	1.2	-	-	-	215	0.10	1.2	-	-	-	-	-	-
	T9325	0.2	205	0.10	1.2	120	0.09	1.2	190	0.10	1.2	-	-	-	-	-	-
	T9335	0.2	170	0.10	1.2	105	0.09	1.2	-	-	-	-	-	-	-	-	-
VBMT 160404E-FM	T5315	0.4	225	0.12	1.2	-	-	-	210	0.12	1.2	-	-	-	-	-	-
	T7325	0.4	130	0.19	1.2	100	0.17	1.2	-	-	-	-	-	-	-	-	-
	T7335	0.4	130	0.19	1.2	100	0.17	1.2	-	-	-	-	-	-	-	-	-
	T8315	0.4	140	0.12	1.2	80	0.11	1.2	130	0.12	1.2	420	0.14	1.2	-	-	-
	T8330	0.4	135	0.12	1.2	80	0.11	1.2	125	0.12	1.2	405	0.14	1.2	-	-	-
	T8430	0.4	165	0.12	1.2	90	0.11	1.2	135	0.12	1.2	450	0.14	1.2	-	-	-
	T9315	0.4	225	0.12	1.2	-	-	-	210	0.12	1.2	-	-	-	-	-	-
	T9325	0.4	165	0.19	1.2	95	0.17	1.2	155	0.19	1.2	-	-	-	-	-	-



Kesme hızı (vc), ilerleme (f) ve kesme derinliği (ap) için uygunluk ve başlangıç değerleri. Daha ileri hesaplamalar için İşleme Hesaplayıcısı uygulamasına başvurun.

Product	RE (mm)	P			M			K			N			S			H		
		vc (m/min)	f (mm/rev)	ap (mm)	vc (m/min)	f (mm/rev)	ap (mm)	vc (m/min)	f (mm/rev)	ap (mm)	vc (m/min)	f (mm/rev)	ap (mm)	vc (m/min)	f (mm/rev)	ap (mm)	vc (m/min)	f (mm/rev)	ap (mm)

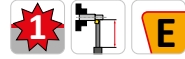
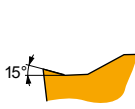

FM geometri, finiştan yarı kaba işleme, ve darbesizden hafif darbeli kesmeye kadar uygun.

VBMT 160408E-FM	T5315	0.8	235	0.17	1.2	-	-	-	220	0.17	1.2	-	-	-	-	-	-	-
	T7325	0.8	165	0.17	1.2	125	0.15	1.2	-	-	-	-	-	-	-	-	-	
	T7335	0.8	160	0.17	1.2	120	0.15	1.2	-	-	-	-	-	-	-	-	-	
	T8315	0.8	150	0.17	1.2	90	0.15	1.2	140	0.17	1.2	450	0.20	1.2	-	-	-	
	T8330	0.8	145	0.17	1.2	85	0.15	1.2	135	0.17	1.2	435	0.20	1.2	-	-	-	
	T8430	0.8	170	0.17	1.2	90	0.15	1.2	135	0.17	1.2	465	0.20	1.2	-	-	-	
	T9310	0.8	255	0.17	1.2	-	-	-	240	0.17	1.2	-	-	-	-	-	-	
	T9315	0.8	230	0.17	1.2	-	-	-	215	0.17	1.2	-	-	-	-	-	-	
	T9325	0.8	205	0.17	1.2	120	0.15	1.2	190	0.17	1.2	-	-	-	-	-	-	
	VBMT 160412E-FM	T7325	1.2	160	0.22	1.2	120	0.22	1.2	-	-	-	-	-	-	-	-	-
T8330		1.2	140	0.22	1.2	80	0.22	1.2	130	0.22	1.2	420	0.26	1.2	-	-	-	
T8430		1.2	155	0.22	1.2	85	0.22	1.2	130	0.22	1.2	435	0.26	1.2	-	-	-	
T9315		1.2	215	0.22	1.2	-	-	-	200	0.22	1.2	-	-	-	-	-	-	
T9325		1.2	195	0.22	1.2	115	0.22	1.2	185	0.22	1.2	-	-	-	-	-	-	

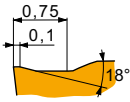

FM2 geometri, finiştan orta işleme kadar, ve darbesizden darbeli kesmeye kadar uygun.

VBMT 160404E-FM2	T6310	0.4	120	0.12	1.2	85	0.11	1.2	95	0.12	1.2	-	-	-	-	-	-
	T7325	0.4	140	0.12	1.2	105	0.11	1.2	-	-	-	-	-	-	-	-	
	T8330	0.4	125	0.12	1.2	75	0.11	1.2	115	0.12	1.2	-	-	-	-	-	
	T8430	0.4	145	0.12	1.2	80	0.11	1.2	120	0.12	1.2	-	-	-	-	-	
	T9315	0.4	200	0.12	1.2	-	-	-	190	0.12	1.2	-	-	-	-	-	
	T9325	0.4	185	0.12	1.2	110	0.11	1.2	175	0.12	1.2	-	-	-	-	-	
	T9335	0.4	155	0.12	1.2	90	0.11	1.2	-	-	-	-	-	-	-	-	
VBMT 160408E-FM2	T6310	0.8	125	0.20	1.2	90	0.18	1.2	100	0.20	1.2	-	-	-	-	-	
	T7325	0.8	145	0.20	1.2	110	0.18	1.2	-	-	-	-	-	-	-		
	T8330	0.8	125	0.20	1.2	75	0.18	1.2	115	0.20	1.2	-	-	-	-		
	T8430	0.8	140	0.20	1.2	75	0.18	1.2	115	0.20	1.2	-	-	-	-		
	T9315	0.8	195	0.20	1.2	-	-	-	185	0.20	1.2	-	-	-	-		
	T9325	0.8	175	0.20	1.2	105	0.18	1.2	165	0.20	1.2	-	-	-	-		
	T9335	0.8	150	0.20	1.2	90	0.18	1.2	-	-	-	-	-	-			
VBMT 160412E-FM2	T8430	1.2	145	0.22	1.2	80	0.20	1.2	120	0.22	1.2	-	-	-	-		
	T9315	1.2	195	0.22	1.2	-	-	-	185	0.22	1.2	-	-	-	-		
	T9325	1.2	175	0.22	1.2	105	0.20	1.2	165	0.22	1.2	-	-	-			

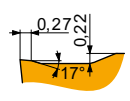

RM geometri, yarı kabadan kaba işleme kadar, ve darbesizden darbeli kesmeye kadar uygun.

VBMT 160404E-RM	T5305	0.4	270	0.12	1.2	-	-	-	255	0.12	1.2	-	-	-	50	0.15	1.0
	T5315	0.4	235	0.12	1.2	-	-	-	220	0.12	1.2	-	-	-	45	0.15	1.0
	T7335	0.4	140	0.18	1.2	105	0.16	1.2	-	-	-	45	0.16	1.0	-	-	
	T8330	0.4	140	0.12	1.2	80	0.11	1.2	130	0.12	1.2	-	-	-	35	0.11	1.0
	T8430	0.4	170	0.12	1.2	90	0.11	1.2	135	0.12	1.2	-	-	-	35	0.11	1.0
	T9315	0.4	235	0.12	1.2	-	-	-	220	0.12	1.2	-	-	-	45	0.15	1.0
	T9325	0.4	170	0.20	1.2	100	0.18	1.2	160	0.20	1.2	-	-	-	35	0.18	1.0
VBMT 160408E-RM	T5305	0.8	285	0.17	1.2	-	-	-	270	0.17	1.2	-	-	-	55	0.15	1.0
	T5315	0.8	250	0.17	1.2	-	-	-	235	0.17	1.2	-	-	-	50	0.15	1.0
	T7335	0.8	155	0.20	1.2	120	0.18	1.2	-	-	-	50	0.18	1.0	-	-	
	T8330	0.8	150	0.17	1.2	90	0.15	1.2	140	0.17	1.2	-	-	-	35	0.12	1.0
	T8430	0.8	175	0.17	1.2	95	0.15	1.2	140	0.17	1.2	-	-	-	35	0.12	1.0
	T9315	0.8	240	0.17	1.2	-	-	-	225	0.17	1.2	-	-	-	45	0.15	1.0
	T9325	0.8	200	0.20	1.2	120	0.18	1.2	190	0.20	1.2	-	-	-	45	0.18	1.0



Kesme hızı (vc), ilerleme (f) ve kesme derinliği (ap) için uygunluk ve başlangıç değerleri. Daha ileri hesaplamalar için İşleme Hesaplayıcısı uygulamasına başvurun.

Product	RE  (mm)	P			M			K			N			S			H		
		vc (m/min)	f (mm/rev)	ap (mm)	vc (m/min)	f (mm/rev)	ap (mm)	vc (m/min)	f (mm/rev)	ap (mm)	vc (m/min)	f (mm/rev)	ap (mm)	vc (m/min)	f (mm/rev)	ap (mm)	vc (m/min)	f (mm/rev)	ap (mm)

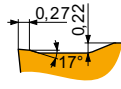

RM geometri, yarı kabadan kaba işleme kadar, ve darbesizden darbeli kesime kadar uygun.

VBMT 160412E-RM	T7335	1.2	✓	150	0.27	1.2	■	115	0.24	1.2	■	–	–	–	■	45	0.19	1.0	–	–	–	
	T8330	1.2	■	140	0.27	1.2	■	80	0.24	1.2	■	130	0.27	1.2	■	35	0.19	1.0	■	25	0.15	1.0
	T8430	1.2	■	155	0.27	1.2	■	85	0.24	1.2	■	130	0.27	1.2	■	30	0.19	1.0	■	25	0.15	1.0
	T9315	1.2	■	210	0.27	1.2	■	–	–	–	■	195	0.27	1.2	■	–	–	–	■	40	0.15	1.0
	T9325	1.2	■	185	0.27	1.2	■	110	0.24	1.2	■	175	0.27	1.2	■	40	0.19	1.0	■	–	–	–

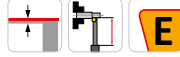
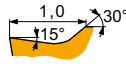

UR geometri, inceden finişe kadar işleme için, ve darbesiz ve hafif darbeli kesim.

VBMT 110202E-UR	TT310	0.2	■	195	0.10	0.8	■	115	0.09	0.8	■	–	–	–	■	–	–	–	–	–	–	
VBMT 110204E-UR	T7325	0.4	■	120	0.19	0.8	■	90	0.17	0.8	■	–	–	–	■	–	–	–	–	–	–	
	T8330	0.4	■	120	0.12	0.8	■	70	0.11	0.8	■	110	0.12	0.8	■	–	–	–	–	–	–	
	T8430	0.4	■	145	0.12	0.8	■	80	0.11	0.8	■	120	0.12	0.8	■	–	–	–	–	–	–	
	T9315	0.4	■	200	0.12	0.8	■	–	–	–	■	190	0.12	0.8	■	–	–	–	–	–	–	
	T9325	0.4	■	150	0.19	0.8	■	90	0.17	0.8	■	140	0.19	0.8	■	–	–	–	–	–	–	
VBMT 160402E-UR	TT310	0.4	■	195	0.12	0.8	■	115	0.11	0.8	■	–	–	–	■	–	–	–	–	–	–	
	T8330	0.2	■	115	0.10	1.2	■	65	0.09	1.2	■	105	0.10	1.2	■	–	–	–	–	–	–	
	T8430	0.2	■	140	0.10	1.2	■	75	0.09	1.2	■	115	0.10	1.2	■	–	–	–	–	–	–	
	VBMT 160404E-UR	T5315	0.4	■	195	0.12	1.2	■	–	–	–	■	185	0.12	1.2	■	–	–	–	–	–	–
		T7325	0.4	■	115	0.19	1.2	■	85	0.17	1.2	■	–	–	–	■	–	–	–	–	–	–
T8330		0.4	■	115	0.12	1.2	■	65	0.11	1.2	■	105	0.12	1.2	■	–	–	–	–	–	–	
T8430		0.4	■	140	0.12	1.2	■	75	0.11	1.2	■	115	0.12	1.2	■	–	–	–	–	–	–	
T9310		0.4	■	215	0.12	1.2	■	–	–	–	■	200	0.12	1.2	■	–	–	–	–	–	–	
VBMT 160408E-UR	T9315	0.4	■	190	0.12	1.2	■	–	–	–	■	180	0.12	1.2	■	–	–	–	–	–	–	
	T9325	0.4	■	145	0.18	1.2	■	85	0.16	1.2	■	135	0.18	1.2	■	–	–	–	–	–	–	
	TT310	0.4	■	185	0.12	1.2	■	110	0.11	1.2	■	–	–	–	■	–	–	–	–	–	–	
	T5315	0.8	■	205	0.17	1.2	■	–	–	–	■	190	0.17	1.2	■	–	–	–	–	–	–	
	T7325	0.8	■	140	0.17	1.2	■	105	0.15	1.2	■	–	–	–	■	–	–	–	–	–	–	
VBMT 160412E-UR	T8330	0.8	■	125	0.17	1.2	■	75	0.15	1.2	■	115	0.17	1.2	■	–	–	–	–	–	–	
	T8430	0.8	■	145	0.17	1.2	■	80	0.15	1.2	■	120	0.17	1.2	■	–	–	–	–	–	–	
	T9310	0.8	■	220	0.17	1.2	■	–	–	–	■	205	0.17	1.2	■	–	–	–	–	–	–	
	T9315	0.8	■	200	0.17	1.2	■	–	–	–	■	190	0.17	1.2	■	–	–	–	–	–	–	
	T9325	0.8	■	180	0.17	1.2	■	105	0.15	1.2	■	170	0.17	1.2	■	–	–	–	–	–	–	
VBMT 160412E-UR	TT310	0.8	■	200	0.17	1.2	■	120	0.15	1.2	■	–	–	–	■	–	–	–	–	–	–	
	T7325	1.2	■	135	0.22	1.2	■	105	0.20	1.2	■	–	–	–	■	–	–	–	–	–	–	
	T8330	1.2	■	120	0.22	1.2	■	70	0.20	1.2	■	110	0.22	1.2	■	–	–	–	–	–	–	
	T8430	1.2	■	135	0.22	1.2	■	75	0.20	1.2	■	110	0.22	1.2	■	–	–	–	–	–	–	
	T9310	1.2	■	205	0.22	1.2	■	–	–	–	■	190	0.22	1.2	■	–	–	–	–	–	–	
T9315	1.2	■	185	0.22	1.2	■	–	–	–	■	175	0.22	1.2	■	–	–	–	–	–	–		
T9325	1.2	■	170	0.22	1.2	■	100	0.20	1.2	■	160	0.22	1.2	■	–	–	–	–	–	–		



VBGW CBN

	IC	D1	L	S
	(mm)	(mm)	(mm)	(mm)
1604	9.525	4.50	16.00	4.76

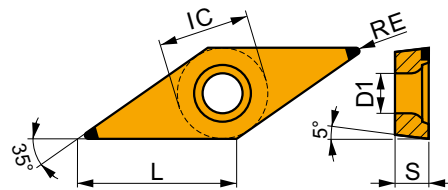

Kesme hızı (vc), ilerleme (f) ve kesme derinliği (ap) için uygunluk ve başlangıç değerleri. Daha ileri hesaplamalar için İşleme Hesaplayıcısı uygulamasına başvurun.

Product	RE (mm)	P			M			K			N			S			H		
		vc (m/min)	f (mm/rev)	ap (mm)	vc (m/min)	f (mm/rev)	ap (mm)	vc (m/min)	f (mm/rev)	ap (mm)	vc (m/min)	f (mm/rev)	ap (mm)	vc (m/min)	f (mm/rev)	ap (mm)			



Finiş işleme ve darbesiz kesme için.

VBGW 160404S01020B	TB310	0.4	-	-	-	-	-	-	-	340	0.10	0.4	-	-	-	90	0.07	0.3	70	0.15	1.0
VBGW 160408S01020B	TB310	0.8	-	-	-	-	-	-	-	350	0.15	0.6	-	-	-	90	0.11	0.5	70	0.15	1.0



SVHB(C)(RL) EXT

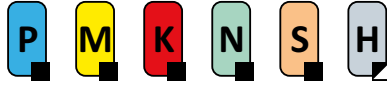

PRAMET

S



VB/VC.. Uç için Vida Sıkmalı 107.5° Açılı Dış Kater

Vida sıkmalı Sağ/Sol dış kater. Pozitif VB/VC.. 11 veya 16 uçlarla çap, alın,konik, 25°'ye kadar kopya ve pah tornalama için uygundur. 16x16-25x25mm shaft ölçülerinde bulunur. Gövde uzun takım ömrü için işlem görmüştür.

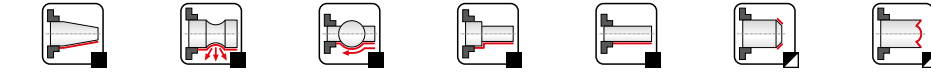
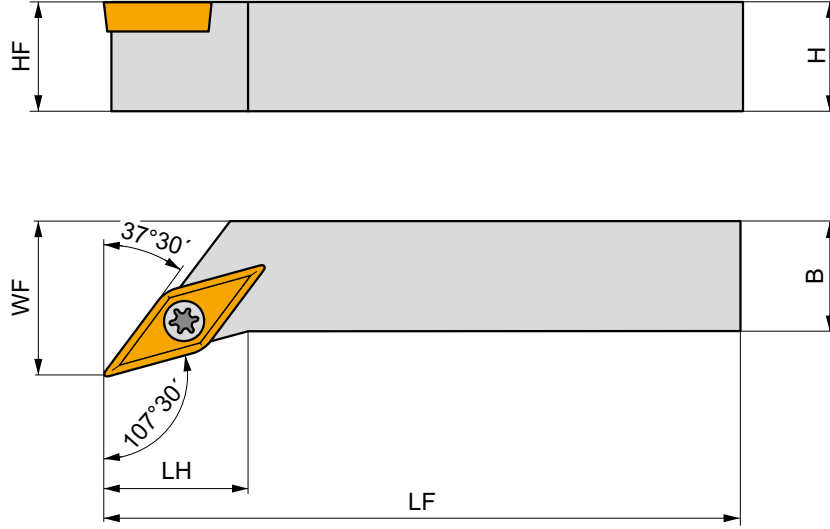
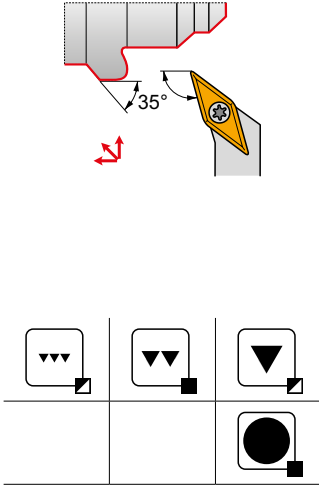

Product	H	B	HF	WF	LF	LH	LAMS	GAMO	kg	GI	SV
	(mm)	(mm)	(mm)	(mm)	(mm)	(mm)	(°)	(°)			
R SVHBR 1616 H 11	16	16	16	20	100	14	0	0	0.21	GI194	S01
SVHCR 2020 K 16-M-A	20	20	20	25	125	20	0	0	0.40	GI017	SV10
SVHCR 2525 M 16-M-A	25	25	25	32	150	20	0	0	0.68	GI017	SV10
L SVHBL 1616 H 11	16	16	16	20	100	14	0	0	0.19	GI194	S01
SVHCL 2020 K 16-M-A	20	20	20	25	125	20	0	0	0.40	GI017	SV10
SVHCL 2525 M 16-M-A	25	25	25	32	150	20	0	0	0.07	GI017	SV10

GI	VB..	VC..
GI017	VB.. 1604..	VC.. 1604..
GI194	VB.. 1103..	VC.. 1103..

SV	US	Nm	M	mm	SVN	MS	FLAG	HXK
S01	US 2506-T07P	0.9	M 2.5	6.3	-	-	FLAG T07P	-
SV10	US 3512-T15P	3.0	M 3.5	12.6	SVN 160304	MS 3510	FLAG T15P	HXK 3.5



SVJB(C)(RL) EXT



PRAMET



VB/VC.. Uç için Vida Sıkmalı 93° Açılı Dış Kater

Vida sıkmalı Sağ/Sol dış kater. Pozitif VB/VC.. 11 veya 16 uçlarla çap, konik, 50°'ye kadar kopya ve pah tornalama için uygundur. 12x12-32x25mm shaft ölçülerinde bulunur. Gövde uzun takım ömrü için işlem görmüştür.

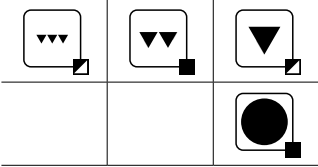
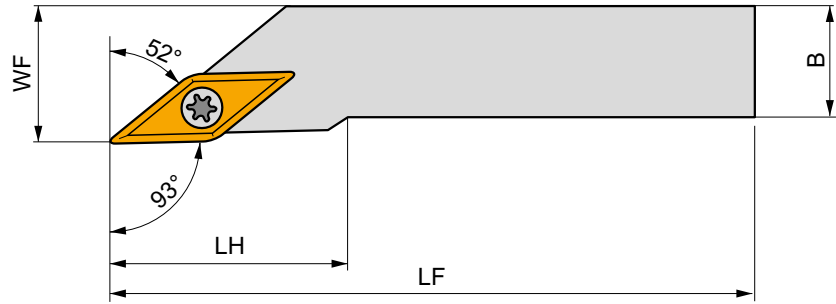
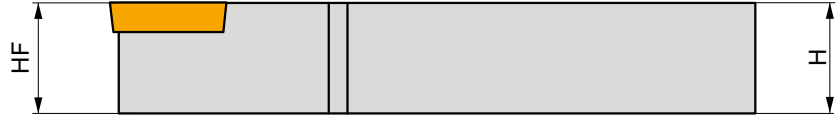
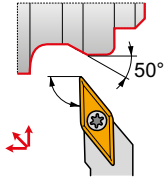

Product	H (mm)	B (mm)	HF (mm)	WF (mm)	LF (mm)	LH (mm)	LAMS (°)	GAMMO (°)	kg	GI	SV
R SVJBR 1212 F 11	12	12	12	16	80	20	0	0	0.09	GI194	SO1
SVJBR 1616 H 11	16	16	16	20	100	20	0	0	0.20	GI194	SO1
SVJCR 1212 N 13	12	12	12	16	160	27	0	0	0.19	GI211	SV21
SVJCR 1616 H 13	16	16	16	20	100	30	0	0	0.20	GI211	SV21
SVJCR 2020 K 13	20	20	20	25	125	30	0	0	0.37	GI211	SV22
SVJCR 2525 M 13	25	25	25	32	150	30	0	0	0.67	GI211	SV22
SVJCR 2020 K 16-M-A	20	20	20	25	125	28	0	0	0.35	GI017	SV10
SVJCR 2525 M 16-M-A	25	25	25	32	150	32	0	0	0.68	GI017	SV10
SVJCR 3225 P 16-M-A	32	25	32	32	170	32	0	0	0.99	GI017	SV10
L SVJBL 1212 F 11	12	12	12	16	80	20	0	0	0.09	GI194	SO1
SVJBL 1616 H 11	16	16	16	20	100	20	0	0	0.19	GI194	SO1
SVJCL 1212 N 13	12	12	12	16	160	27	0	0	0.19	GI211	SV21
SVJCL 1616 H 13	16	16	16	20	100	30	0	0	0.20	GI211	SV21
SVJCL 2020 K 13	20	20	20	25	125	30	0	0	0.37	GI211	SV22
SVJCL 2525 M 13	25	25	25	32	150	30	0	0	0.67	GI211	SV22
SVJCL 2020 K 16-M-A	20	20	20	25	125	28	0	0	0.40	GI017	SV10
SVJCL 2525 M 16-M-A	25	25	25	32	150	32	0	0	0.70	GI017	SV10
SVJCL 3225 P 16-M-A	32	25	32	32	170	32	0	0	0.99	GI017	SV10



GI017
GI194
GI211

VB.. 1604..
VB.. 1103..
-

VC.. 1604..
VC.. 1103..
VC.. 1303..



SO1
SV10
SV21
SV22

US 2506-T07P
US 3512-T15P
5513 020-24
DVF 0573

0.9
3.0
1.5
1.5

M 2.5
M 3.5
M 3
M 3

6.3
12.6
8.5
10.3

-
SVN 160304
-
DAP 0331

-
MS 3510
-
DVT 0332

FLAG T07P
FLAG T15P
PT-8002
PT-8002

-
HXK 3.5
-
174.1-870



SVPB(C)(RL) EXT

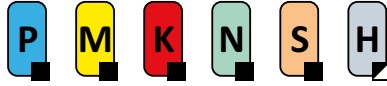

PRAMET

S



VB/VC.. Uç için Vida Sıkmalı 117.5° Açılı Dış Kater

Vida sıkmalı Sağ/Sol dış kater. Pozitif VB/VC.. 11 veya 16 uçlarla çap, alın,konik, 25°'ye kadar kopya ve pah tornalama için uygundur. 16x16-32x25mm şaft ölçülerinde bulunur. Gövde uzun takım ömrü için işlem görmüştür.

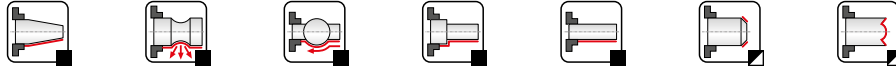
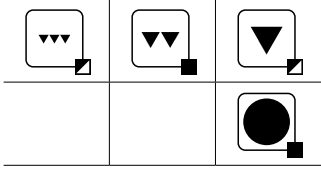
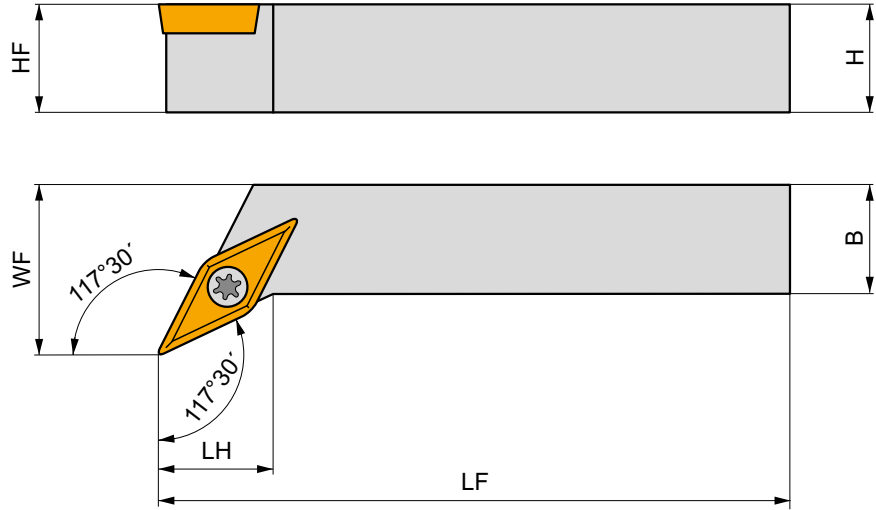
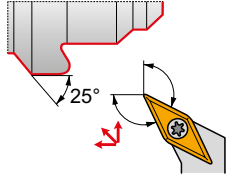

Product	H	B	HF	WF	LF	LH	LAMS	GAMO	kg	Icon 1	Icon 2
	(mm)	(mm)	(mm)	(mm)	(mm)	(mm)	(°)	(°)			
R SVPBR 1616 H 11	16	16	16	20	100	12	0	0	0.20	GI194	S01
SVPBR 2020 K 11	20	20	20	25	125	12	0	0	0.41	GI194	S01
SVPCR 2020 K 16-M-A	20	20	20	25	125	20	0	0	0.40	GI017	SV10
SVPCR 2525 M 16-M-A	25	25	25	32	150	25	0	0	0.75	GI017	SV10
SVPCR 3225 P 16-M-A	32	25	32	32	170	25	0	0	1.10	GI017	SV10
L SVPBL 1616 H 11	16	16	16	20	100	12	0	0	0.20	GI194	S01
SVPBL 2020 K 11	20	20	20	25	125	12	0	0	0.39	GI194	S01
SVPCL 2020 K 16-M-A	20	20	20	25	125	20	0	0	0.70	GI017	SV10
SVPCL 2525 M 16-M-A	25	25	25	32	150	25	0	0	0.70	GI017	SV10
SVPCL 3225 P 16-M-A	32	25	32	32	170	25	0	0	1.10	GI017	SV10

Icon 1	Icon 2	Icon 3
GI017	VB.. 1604..	VC.. 1604..
GI194	VB.. 1103..	VC.. 1103..

Icon 1	Icon 2	Icon 3	Icon 4	Icon 5	Icon 6	Icon 7	Icon 8	Icon 9
S01	US 2506-T07P	0.9	M 2.5	6.3	-	-	FLAG T07P	-
SV10	US 3512-T15P	3.0	M 3.5	12.6	SVN 160304	MS 3510	FLAG T15P	HXK 3.5



SVVB(C)N EXT



PRAMET

S



VB/VC.. Uç için Vida Sıklı 72.5° Açılı Dış Kater

Vida sıklı nötr dış kater. Pozitif VB/VC.. 11 ve 16 uçlarla çap, 72.5°'ye kadar kopya, konik ve pah tornalama için uygundur. 12x12-32x25mm mevcuttur. Gövde uzun takım ömrü için işlem görmüştür.

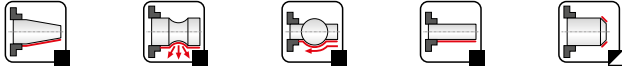
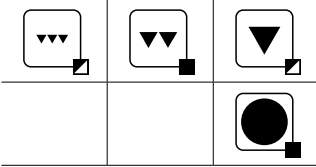
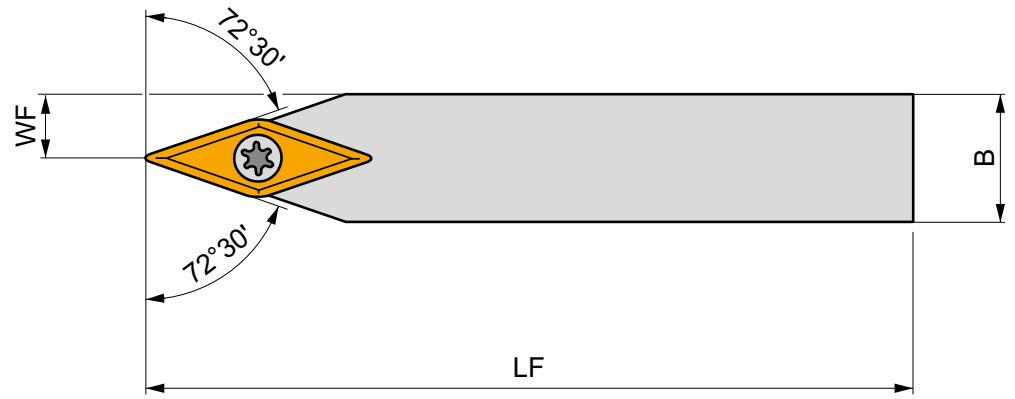
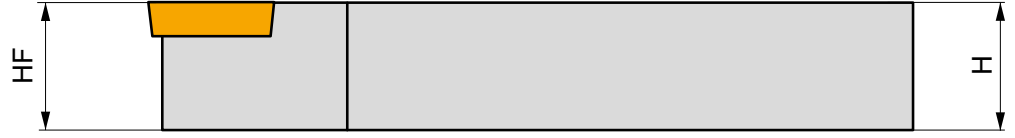
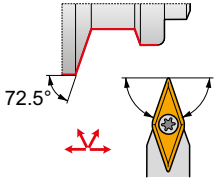

Product	H (mm)	B (mm)	HF (mm)	WF (mm)	LF (mm)	LH (mm)	LAMS (°)	GAM0 (°)	kg	GI	SV
N SVVBN 1212 F 11	12	12	12	6	80	-	0	0	0.11	GI194	S01
SVVBN 1616 H 11	16	16	16	8	100	-	0	0	0.18	GI194	S01
SVVBN 2020 K 11	20	20	20	10	125	-	0	0	0.38	GI194	S01
SVVCN 1212 N 13	12	12	12	6	160	-	0	0	0.19	GI211	SV21
SVVCN 1616 H 13	16	16	16	8	100	-	0	0	0.20	GI211	SV21
SVVCN 2020 K 13	20	20	20	10	125	-	0	0	0.36	GI211	SV22
SVVCN 2525 M 13	25	25	25	12.5	150	-	0	0	0.66	GI211	SV22
SVVCN 2020 K 16-M-A	20	20	20	10	125	-	0	0	0.34	GI017	SV10
SVVCN 2525 M 16-M-A	25	25	25	12.5	150	-	0	0	0.68	GI017	SV10
SVVCN 3225 P 16-M-A	32	25	32	12.5	170	-	0	0	0.98	GI017	SV10

GI	VB..	VC..
GI017	VB.. 1604..	VC.. 1604..
GI194	VB.. 1103..	VC.. 1103..
GI211	-	VC.. 1303..

SV	US	Nm	M	mm	SVN	MS	PT	HXX
S01	US 2506-T07P	0.9	M 2.5	6.3	-	-	FLAG T07P	-
SV10	US 3512-T15P	3.0	M 3.5	12.6	SVN 160304	MS 3510	FLAG T15P	HXX 3.5
SV21	5513 020-24	1.5	M 3	8.5	-	-	PT-8002	-
SV22	DVF 0573	1.5	M 3	10.3	DAP 0331	DVT 0332	PT-8002	174.1-870



SVXB(C)(RL) EXT

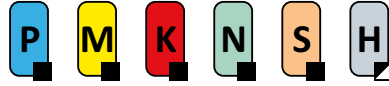

PRAMET

S



VB/VC.. Uç için Vida Sıklı 98/113° Açılı Dış Kater

Vida sıklı Sağ/Sol dış kater. Pozitif VB/VC.. 11 veya 16 uçlarla çap, konik, 30°'ye kadar kopya ve pah tormalama için uygundur. 12x12-32x25mm saft ölçülerinde bulunur. Gövde uzun takım ömrü için işlem görmüştür.

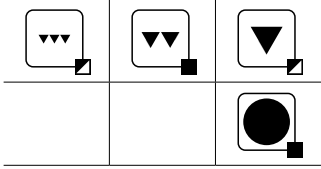
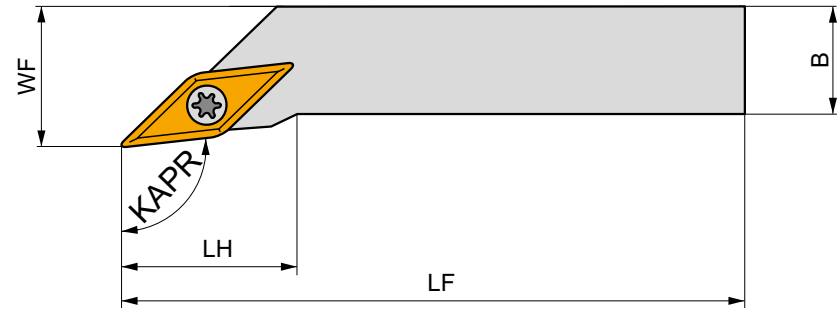
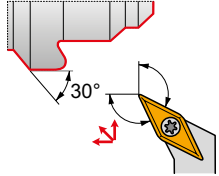

Product	H	B	HF	WF	LF	LH	KAPR	LAMS	GAMO	kg	GI	SV
	(mm)	(mm)	(mm)	(mm)	(mm)	(mm)	(°)	(°)	(°)			
R SVXBR 1212 F 11	12	12	12	16	80	20	98	0	0	0.09	GI194	SO1
SVXBR 1616 H 11	16	16	16	20	100	14	98	0	0	0.19	GI194	SO1
SVXCR 2020 K 13	20	20	20	25	125	12	113	0	0	0.38	GI211	SV22
SVXCR 2020 K 16-M-A	20	20	20	25	125	28	98	0	0	0.41	GI017	SV10
SVXCR 2525 M 16-M-A	25	25	25	32	150	32	98	0	0	0.68	GI017	SV10
SVXCR 3225 P 16-M-A	32	25	32	32	170	32	98	0	0	1.00	GI017	SV10
L SVXBL 1212 F 11	12	12	12	16	80	20	98	0	0	0.09	GI194	SO1
SVXBL 1616 H 11	16	16	16	20	100	14	98	0	0	0.19	GI194	SO1
SVXCL 2020 K 13	20	20	20	25	125	12	113	0	0	0.38	GI211	SV22
SVXCL 2020 K 16-M-A	20	20	20	25	125	28	98	0	0	0.38	GI017	SV10
SVXCL 2525 M 16-M-A	25	25	25	32	150	32	98	0	0	0.69	GI017	SV10
SVXCL 3225 P 16-M-A	32	25	32	32	170	32	98	0	0	0.99	GI017	SV10



GI017

VB.. 1604..

VC.. 1604..

GI194

VB.. 1103..

VC.. 1103..

GI211

-

VC.. 1303..



Nm



SO1

US 2506-T07P

0.9

M 2.5

6.3

-

-

FLAG T07P

-

SV10

US 3512-T15P

3.0

M 3.5

12.6

SVN 160304

MS 3510

FLAG T15P

HXK 3.5

SV22

DVF 0573

1.5

M 3

10.3

DAP 0331

DVT 0332

PT-8002

174.1-870

NEW
C.-SVHB(RL) EXT

PRAMET
S

VB/VC.. Uç için Vida Sıkmalı, 107.5° Açılı Hızlı Değişirme Dış Takımı

Vida sıkmalı Sağ/Sol, içten su vermeli dış kater. Pozitif VB/VC.. 16 uçlarla çap,konik, 35°'ye kadar kopya ve pah tornalama için uygundur. PSC C4-C6 ölçülerinde bulunur. Gövde uzun takım ömrü için işlem görmüştür.

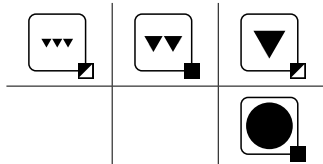
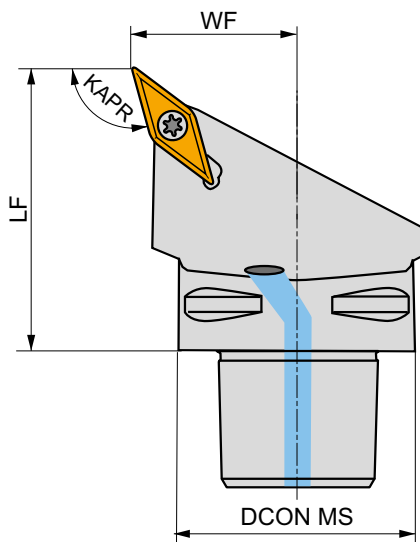
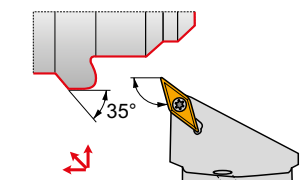

Product	DCON MS	WF	LF	KAPR	LAMS	GAMO		kg			
	(mm)	(mm)	(mm)	(°)	(°)	(°)					
R	C4-SVHBR-27050-16	40	27	50	107.5	0	0	✓	0.35	GI017	C-SV16S-1
	C5-SVHBR-35060-16	50	35	60	107.5	0	0	✓	0.64	GI017	C-SV16S-2
	C6-SVHBR-45065-16	63	45	65	107.5	0	0	✓	1.13	GI017	C-SV16S-2
L	C4-SVHBL-27050-16	40	27	50	107.5	0	0	✓	0.35	GI017	C-SV16S-1
	C5-SVHBL-35060-16	50	35	60	107.5	0	0	✓	0.64	GI017	C-SV16S-2
	C6-SVHBL-45065-16	63	45	65	107.5	0	0	✓	1.12	GI017	C-SV16S-2



GI017

VB.. 1604..

VC.. 1604..



C-SV16S-1

US 2001-T15P

3.0

M 3.5

12.1

SVS 270-01

MS 9001

FLAGT15P/3,5

CN 034-01

C-SV16S-2

US 2001-T15P

3.0

M 3.5

12.1

SVS 270-01

MS 9001

FLAGT15P/3,5

CN 034-02

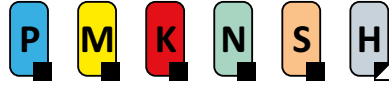
**NEW****C.-SVJB(RL) EXT**

PRAMET

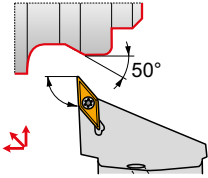
S**VB/VC.. Uç için Vida Sıkmalı, 93° Açılı Hızlı Değişirme Dış Takımı**

Vida sıkmalı Sağ/Sol, içten su vermeli dış kater. Pozitif VB/VC.. 11 veya 16 uçlarla çap, konik, 50°'ye kadar kopya ve pah tornalama için uygundur. PSC C3-C6 ölçülerinde bulunur. Gövde uzun takım ömrü için işlem görmüştür.

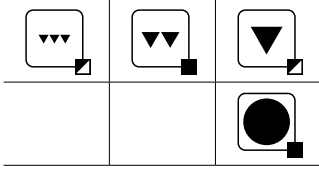
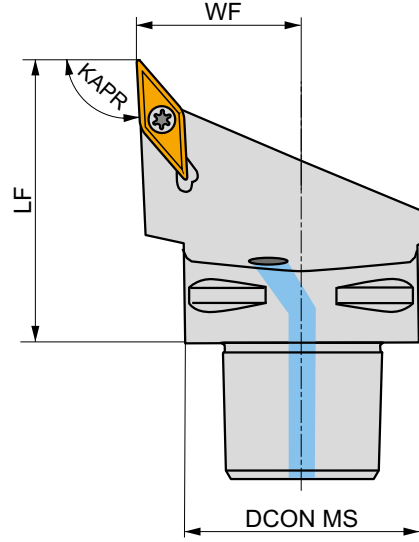

Product	DCON MS (mm)	WF (mm)	LF (mm)	KAPR (°)	LAMS (°)	GAMO (°)		kg		
R C3-SVJBR-22040-11-B1	32	22	40	93	0	0	✓	0.17	GI194	C-SV11
C4-SVJBR-27050-11-B1	40	27	50	93	0	0	✓	0.34	GI194	C-SV11
C4-SVJBR-27050-16	40	27	50	93	0	0	✓	0.35	GI017	C-SV16S-1
C5-SVJBR-35060-16	50	35	60	93	0	0	✓	0.63	GI017	C-SV16S-2
C6-SVJBR-45065-16	63	45	65	93	0	0	✓	1.11	GI017	C-SV16S-2
L C4-SVJBL-27050-16	40	27	50	93	0	0	✓	0.35	GI017	C-SV16S-1
C5-SVJBL-35060-16	50	35	60	93	0	0	✓	0.64	GI017	C-SV16S-2
C6-SVJBL-45065-16	63	45	65	93	0	0	✓	1.11	GI017	C-SV16S-2

GI017	VB.. 1604..	VC.. 1604..
GI194	VB.. 1103..	VC.. 1103..

C-SV11	US 2003-T07P	0.8	M 2.5	6.5	-	-	FLAG T07P	CN 034-01
C-SV16S-1	US 2001-T15P	3.0	M 3.5	12.1	SVS 270-01	MS 9001	FLAG T15P/3,5	CN 034-01
C-SV16S-2	US 2001-T15P	3.0	M 3.5	12.1	SVS 270-01	MS 9001	FLAG T15P/3,5	CN 034-02

NEW
C-SVBN EXT

PRAMET
S

Vida Sıkmalı VB/VC.. Uç için PSC Hızlı Değişirme 72.5° Dış Kateri

Vida sıkmalı, içten su vermeli nötr dış kater. Pozitif VB/VC.. 16 uçlarla çap, 72.5°'ye kadar kopya, konik ve pah tornalamak için uygundur. C4'ten C6'ya kadar PSC şaftlı mevcuttur. Tutucu uzun takım ömrü için işlem görmüştür.

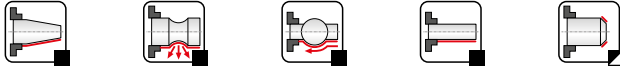
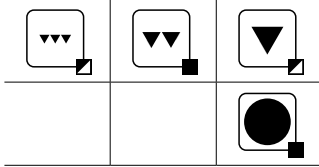
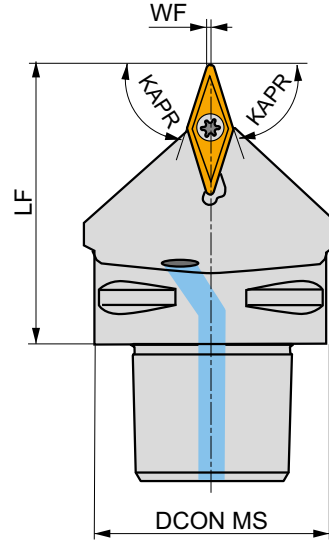
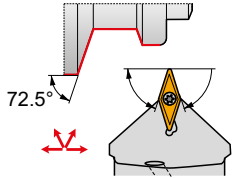

Product	DCON MS (mm)	WF (mm)	LF (mm)	KAPR (°)	LAMS (°)	GAMO (°)				
N C4-SVBN-00050-16	40	0.6	50	72.5	0	0	✓	0.32	GI017	C-SV16S-1
C5-SVBN-00060-16	50	0.6	60	72.5	0	0	✓	0.56	GI017	C-SV16S-2
C6-SVBN-00065-16	63	0.6	65	72.5	0	0	✓	0.99	GI017	C-SV16S-2

GI017	VB.. 1604..	VC.. 1604..

C-SV16S-1	US 2001-T15P	3.0	M 3.5	12.1	SVS 270-01	MS 9001	FLAG T15P/3,5	CN 034-01
C-SV16S-2	US 2001-T15P	3.0	M 3.5	12.1	SVS 270-01	MS 9001	FLAG T15P/3,5	CN 034-02



SVJB(RL) INT

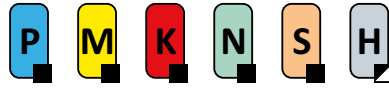

PRAMET

S



VB/VC.. Uç için Vida Sıkmalı 93° Açılı Delik Kateri

Vida sıkmalı Sağ/Sol 93° içten su vermeli delik kateri. Pozitif VB/VC.. 11 uçlarla minimum Ø25mm çap, ve 50°'ye kadar kopya tornalama için uygundur. Ø20 ve Ø25mm shaft ölçülerinde bulunur. Gövde uzun takım ömrü için işlem görmüştür.

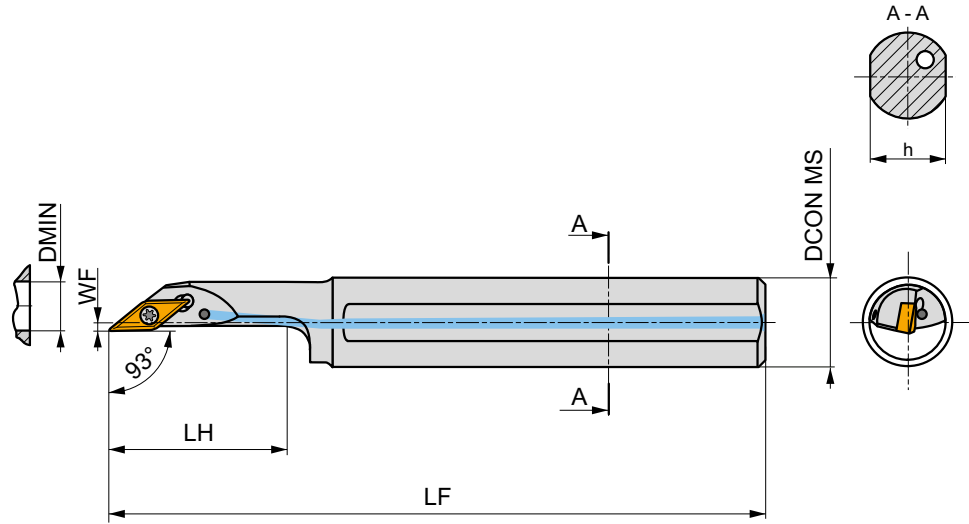
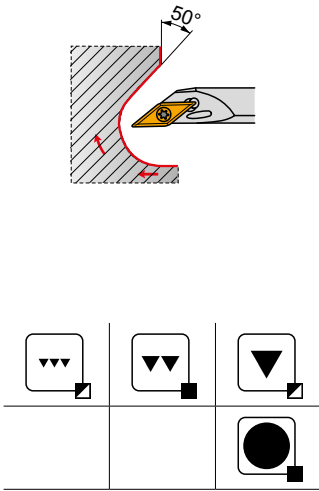

Product	DCON MS (mm)	DMIN (mm)	WF (mm)	H (mm)	LF (mm)	LH (mm)	LAMS (°)	GAMO (°)		kg		
R A20R-SVJBR 11	20	25	2	18	200	40	-5	-5	✓	0.44	GI194	S07
A25S-SVJBR 11	25	32	3.5	23	250	50	-5	-5	✓	0.82	GI194	S07
L A20R-SVJBL 11	20	25	2	18	200	40	-5	-5	✓	0.42	GI194	S07
A25S-SVJBL 11	25	32	3.5	23	250	50	-5	-5	✓	0.82	GI194	S07



GI194



VB.. 1103..



VC.. 1103..



S07



US 2506-T07P



0.9



M 2.5



6.3



FLAG T07P



SVQB(C)(RL) INT



VB/VC.. Uç için Vida Sıkmalı 107.5° Açılı Delik Kateri

Vida sıkmalı Sağ/Sol 107.5° içten su vermeli delik kateri. Pozitif VB/VC.. 11 veya 16 uçlarla minimum Ø20mm çap ve birçok uygulama için uygundur. Ø16-40mm shaft ölçülerinde bulunur. Gövde uzun takım ömrü için işlem görmüştür.

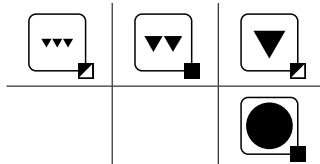
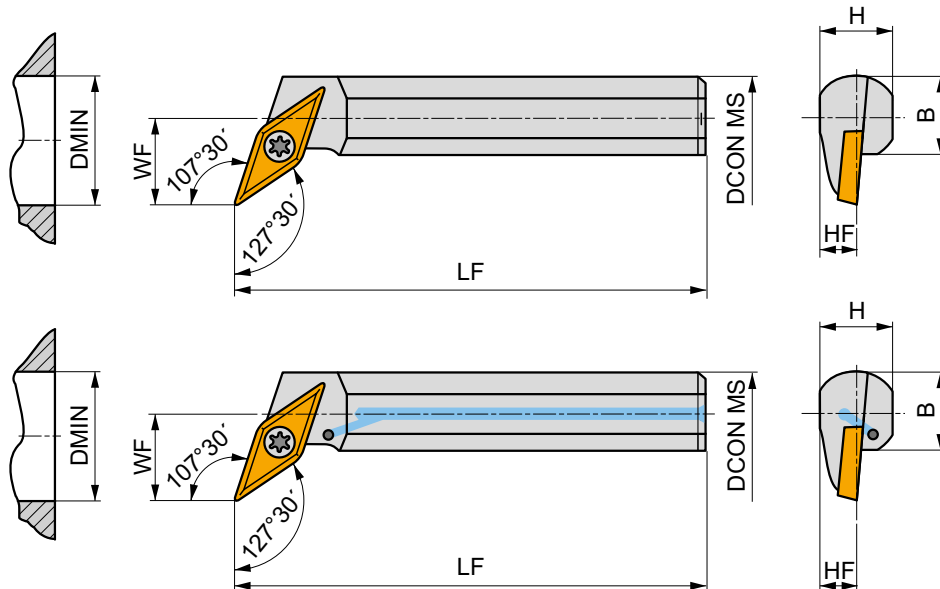
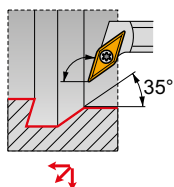

Product	DCON MS (mm)	DMIN (mm)	WF (mm)	H (mm)	B (mm)	LF (mm)	LAMS (°)	GAMO (°)					
R	A16R-SVQBR 11	16	20	11	14.5	15	200	-5	0	✓	0.33	GI194	S01
	A20S-SVQBR 11	20	25	13	18	18.5	250	-4	0	✓	0.58	GI194	S01
	A16R-SVQCR 13	16	21	11	15	15	200	-6	0	✓	0.30	GI211	SV21
	A20S-SVQCR 13	20	25	13	18	18.5	250	-4	0	✓	0.12	GI211	SV21
	S25T-SVQCR 16	25	32	17	23	23	300	-7	0	-	1.10	GI017	S08
	S32U-SVQCR 16	32	40	22	30	30	350	-5	0	-	2.07	GI017	S08
	S40V-SVQCR 16-A	40	50	27	38	38	400	-5	0	-	3.80	GI017	SV10
L	A16R-SVQBL 11	16	20	11	14.5	15	200	-5	0	✓	0.33	GI194	S01
	A20S-SVQBL 11	20	25	13	18	18.5	250	-4	0	✓	0.58	GI194	S01
	A16R-SVQCL 13	16	21	11	15	15	200	-6	0	✓	0.29	GI211	SV21
	A20S-SVQCL 13	20	25	13	18	18.5	250	-4	0	✓	0.54	GI211	SV21
	S25T-SVQCL 16	25	32	17	23	23	300	-7	0	-	1.09	GI017	S08
	S32U-SVQCL 16	32	40	22	30	30	350	-5	0	-	2.07	GI017	S08
	S40V-SVQCL 16-A	40	50	27	38	38	400	-5	0	-	4.10	GI017	SV10



GI017

VB.. 1604..

VC.. 1604..

GI194

VB.. 1103..

VC.. 1103..

GI211

-

VC.. 1303..



S01

US 2506-T07P

0.9

M 2.5

6.3

-

-

FLAGT07P

-

S08

US 3510-T15P

3.0

M 3.5

10.6

-

-

FLAGT15P

-

SV10

US 3512-T15P

3.0

M 3.5

12.6

SVN 160304

MS 3510

FLAGT15P

HXK 3.5

SV21

5513 020-24

1.5

M 3

8.5

-

-

PT-8002

-



SVUB(C)(RL) INT

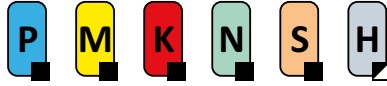

PRAMET

S



VB/VC.. Uç için Vida Sıkmalı 93° Açılı Delik Kateri

Vida sıkmalı Sağ/Sol 93° içten su vermeli delik kateri. Pozitif VB/VC.. 11 veya 16 uçlarla minimum Ø20mm çap, ve 50°'ye kadar kopya tornalama için uygundur. Ø16-40mm shaft ölçülerinde bulunur. Gövde uzun takım ömrü için işlem görmüştür.

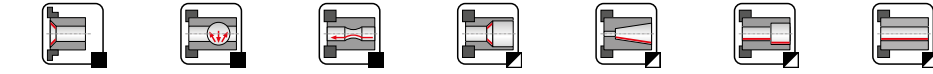
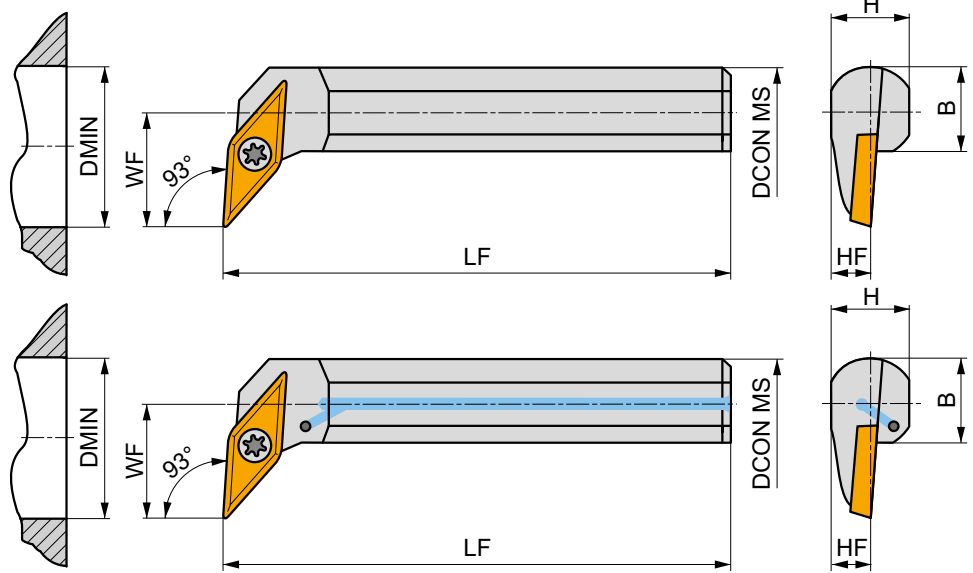
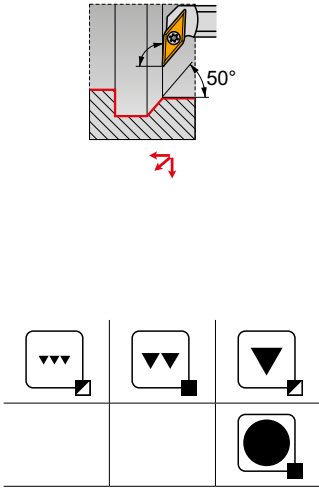

Product	DCON MS (mm)	DMIN (mm)	WF (mm)	H (mm)	B (mm)	LF (mm)	LAMS (°)	GAMO (°)	✓	kg	GI194	S01
R A16R-SVUBR 11	16	20	11	14.5	15	200	-5	0	✓	0.34	GI194	S01
A20S-SVUBR 11	20	25	13	18	18.8	250	-4	0	✓	0.58	GI194	S01
A20S-SVUCR 13	20	25	13	19	18.5	250	-4	2	✓	0.40	GI211	SV21
A25T-SVUCR 13	25	32	17	24	23	300	-2	2	✓	0.96	GI211	SV22
A32T-SVUCR 13	32	40	22	30	30	300	-1	2	✓	1.70	GI211	SV22
S25T-SVUCR 16	25	32	17	23	23	300	-7	0	-	1.10	GI017	S08
S32U-SVUCR 16	32	40	22	30	30	350	-5	0	-	2.10	GI017	S08
S40V-SVUCR 16-A	40	50	27	38	38	400	-5	0	-	4.10	GI017	SV10
L A16R-SVUBL 11	16	20	11	14.5	15	200	-5	0	✓	0.34	GI194	S01
A20S-SVUBL 11	20	25	13	18	18.5	250	-4	0	✓	0.58	GI194	S01
A20S-SVUCL 13	20	25	13	19	18.5	250	-4	2	✓	0.32	GI211	SV21
A25T-SVUCL 13	25	32	17	24	23	300	-2	2	✓	0.96	GI211	SV22
A32T-SVUCL 13	32	40	22	30	30	300	-1	2	✓	1.70	GI211	SV22
S25T-SVUCL 16	25	32	17	23	23	300	-7	0	-	1.10	GI017	S08
S32U-SVUCL 16	32	40	22	30	30	350	-5	0	-	2.10	GI017	S08
S40V-SVUCL 16-A	40	50	27	38	38	400	-5	0	-	4.10	GI017	SV10

GI017	VB.. 1604..	VC.. 1604..
GI194	VB.. 1103..	VC.. 1103..
GI211	-	VC.. 1303..

S01	US 2506-T07P	0.9	M 2.5	6.3	-	-	FLAG T07P	-
S08	US 3510-T15P	3.0	M 3.5	10.6	-	-	FLAG T15P	-
SV10	US 3512-T15P	3.0	M 3.5	12.6	SVN 160304	MS 3510	FLAG T15P	HXK 3.5
SV21	5513 020-24	1.5	M 3	8.5	-	-	PT-8002	-
SV22	DVF 0573	1.5	M 3	10.3	DAP 0331	DVT 0332	PT-8002	174.1-870

NEW
C.-SVQB(RL) INT

PRAMET
S

VB/VC.. Uç için Vida Sıkmalı 107.5° Açılı PSC Hızlı Değişirme Delik Takımı

Vida sıkmalı Sağ/Sol 107.5° içten su vermeli delik kateri. Pozitif VB/VC.. 16 uçlarla minimum Ø33mm çap ve birçok uygulama için uygundur. C4 ve C5 shaft ve çeşitli boy ölçülerinde bulunur. Gövde uzun takım ömrü için işlem görmüştür.

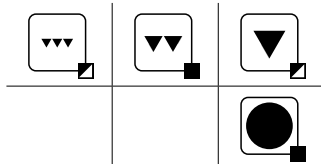
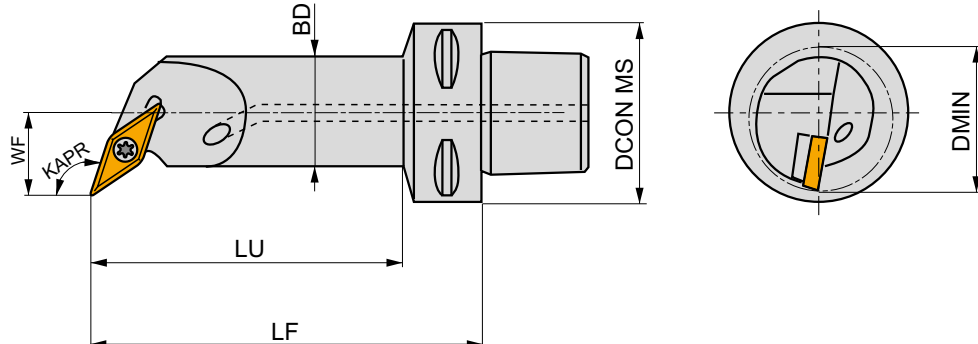
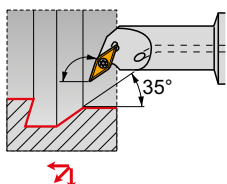

Product	DCON MS (mm)	DMIN (mm)	WF (mm)	LF (mm)	LU (mm)	BD (mm)	KAPR (°)	LAMS (°)	GAMO (°)				
R C4-SVQBR-18090-16	40	33	18	90	68	25	107.5	-7.2	0	✓	0.48	GI017	SV16
C5-SVQBR-18090-16	50	33	18	90	67	25	107.5	-7.2	0	✓	0.67	GI017	SV16
L C4-SVQBL-18090-16	40	33	18	90	68	25	107.5	-7.2	0	✓	0.48	GI017	SV16
C5-SVQBL-18090-16	50	33	18	90	67	25	107.5	-7.2	0	✓	0.68	GI017	SV16



GI017



VB.. 1604..



VC.. 1604..



SV16



US 2010-T15P



3.0



M 3.5



10.1



FLAG T15P/3,5



VC

07/ 11/ 13/ 16

KARBÜR UÇLAR

VCGT	VCGW	VCGX	VCMT	VCMW
186	189	189	190	191

PCD UÇLAR

VCMW PCD
192

DOĞRU BOYUTLA EŞLEŞTİRİN (örnek)

Kesici uç	Takım Tutucu
VCGT 070204E-FF2	SVGCR 1010 M 07

ISO TORNALAMA - DIŞ

SVAC(RL)-DC EXT	SVGC(RL) EXT	SVHB(C)(RL) EXT	SVJB(C)(RL) EXT
<p>90°</p> <p>VC..</p> <p>13</p> <p>10x10 25x25</p> <p>193</p> <p>186 - 192</p>	<p>90°</p> <p>VC..</p> <p>07</p> <p>08x08 16x16</p> <p>194</p> <p>186 - 192</p>	<p>107°30'</p> <p>VB, VC..</p> <p>11 16</p> <p>16x16 25x25</p> <p>195</p> <p>168 - 171 186 - 192</p>	<p>93°</p> <p>VB, VC..</p> <p>11 13 16</p> <p>12x12 32x25</p> <p>196</p> <p>168 - 171 186 - 192</p>
SVJC(RL)-DC EXT	SVPB(C)(RL) EXT	SVVB(C)N EXT	SVXB(C)(RL) EXT
<p>93°</p> <p>VC..</p> <p>13</p> <p>10x10 25x25</p> <p>197</p> <p>186 - 192</p>	<p>117°30'</p> <p>VB, VC..</p> <p>11 16</p> <p>16x16 32x25</p> <p>198</p> <p>168 - 171 186 - 192</p>	<p>72°30'</p> <p>VB, VC..</p> <p>11 13 16</p> <p>12x12 32x25</p> <p>199</p> <p>168 - 171 186 - 192</p>	<p>98°</p> <p>VB, VC..</p> <p>11 13 16</p> <p>12x12 32x25</p> <p>200</p> <p>168 - 171 186 - 192</p>



VC

07/ 11/ 13/ 16

C.-SVHB(RL) EXT **NEW**

107°30'	VB, VC..
	 16
	$\frac{C4}{C6}$
201	168 – 171 186 – 192

C.-SVJB(RL) EXT **NEW**

93°	VB, VC..
	 11 16
	$\frac{C3}{C6}$
202	168 – 171 186 – 192

C.-SVVBN EXT **NEW**

72°30'	VB, VC..
	 16
	$\frac{C4}{C6}$
203	168 – 171 186 – 192

ISO TORNALAMA - İÇ

SVJB(RL) INT

93°	VB, VC..
	 11
	$\frac{25}{32}$
204	168 – 171 186 – 192

SVLC(RL) INT

95°	VC..
	 13
	$\frac{27}{43}$
205	186 – 192

SVQB(C)(RL) INT

107°30'	VB, VC..
	 11 13 16
	$\frac{20}{50}$
206	168 – 171 186 – 192

SVUB(C)(RL) INT

93°	VB, VC..
	 11 13 16
	$\frac{20}{50}$
207	168 – 171 186 – 192

SVXC(RL) INT

113°	VC..
	 07
	$\frac{12,5}{17,5}$
208	186 – 192

SVXC(RL)-E INT

113°	VC..
	 07
	$\frac{12,5}{17,5}$
209	186 – 192

C.-SVQB(C)(RL) INT **NEW**

108°	VB, VC..
	 16
	33
210	168 – 171 186 – 192



VCGT



	IC	D1	L	S
	(mm)	(mm)	(mm)	(mm)
0702	3.970	2.20	6.90	2.38
1102-SF3	6.350	2.80	11.10	2.58
1103	6.350	2.80	11.10	3.18
1103-SF3	6.350	2.80	11.10	3.43
1303	7.940	3.40	13.80	3.18
1303-AL	7.940	3.40	13.80	3.43
1303-SF3	7.940	3.40	13.80	3.43
1604	9.525	4.40	16.60	4.76
1604-SF3	9.525	4.40	16.60	5.01

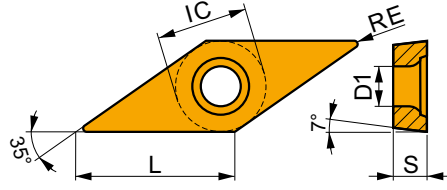

Kesme hızı (vc), ilerleme (f) ve kesme derinliği (ap) için uygunluk ve başlangıç değerleri. Daha ileri hesaplamalar için İşleme Hesaplayıcısı uygulamasına başvurun.

Product	RE	P			M			K			N			S			H		
		vc	f	ap	vc	f	ap	vc	f	ap	vc	f	ap	vc	f	ap	vc	f	ap
	(mm)	(m/min)	(mm/rev)	(mm)	(m/min)	(mm/rev)	(mm)	(m/min)	(mm/rev)	(mm)	(m/min)	(mm/rev)	(mm)	(m/min)	(mm/rev)	(mm)	(m/min)	(mm/rev)	(mm)



AL geometri, ince finişten kabaya, ve darbesizden hafif darbeli kesmeye kadar uygun, çok pozitif tasarım.

VCGT 070202F-AL	HF7	0.2	-	-	-	-	-	-	-	■	315	0.12	1.0	-	-	-	-	-	-
VCGT 110302F-AL	HF7	0.2	-	-	-	-	-	-	-	■	300	0.12	1.5	-	-	-	-	-	-
	T0315	0.2	-	-	-	-	-	-	-	■	465	0.12	0.8	-	-	-	-	-	-
VCGT 110304F-AL	HF7	0.4	-	-	-	-	-	-	-	■	240	0.24	1.5	-	-	-	-	-	-
	T0315	0.4	-	-	-	-	-	-	-	■	375	0.24	0.8	-	-	-	-	-	-
VCGT 130302F-AL	HF7	0.2	-	-	-	-	-	-	-	■	285	0.12	1.7	-	-	-	-	-	-
	T0315	0.2	-	-	-	-	-	-	-	■	420	0.12	1.7	-	-	-	-	-	-
VCGT 130304F-AL	HF7	0.4	-	-	-	-	-	-	-	■	240	0.24	1.7	-	-	-	-	-	-
	T0315	0.4	-	-	-	-	-	-	-	■	345	0.24	1.7	-	-	-	-	-	-
VCGT 130308F-AL	HF7	0.8	-	-	-	-	-	-	-	■	210	0.48	1.7	-	-	-	-	-	-
	T0315	0.8	-	-	-	-	-	-	-	■	315	0.48	1.7	-	-	-	-	-	-
VCGT 160402F-AL	HF7	0.2	-	-	-	-	-	-	-	■	285	0.12	2.4	-	-	-	-	-	-
	T0315	0.2	-	-	-	-	-	-	-	■	420	0.12	2.4	-	-	-	-	-	-
VCGT 160404F-AL	HF7	0.4	-	-	-	-	-	-	-	■	225	0.24	2.4	-	-	-	-	-	-
	T0315	0.4	-	-	-	-	-	-	-	■	330	0.24	2.4	-	-	-	-	-	-
VCGT 160408F-AL	HF7	0.8	-	-	-	-	-	-	-	■	210	0.48	2.4	-	-	-	-	-	-
	T0315	0.8	-	-	-	-	-	-	-	■	300	0.48	2.4	-	-	-	-	-	-
VCGT 160412F-AL	HF7	1.2	-	-	-	-	-	-	-	■	180	0.72	2.4	-	-	-	-	-	-
	T0315	1.2	-	-	-	-	-	-	-	■	270	0.72	2.4	-	-	-	-	-	-

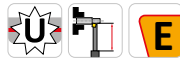
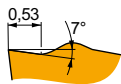

FF2 geometri, ince-finişten finiş işleme kadar için çok pozitif tasarım, darbesizden hafif darbeli işleme kadar uygun.

VCGT 070202E-FF2	T8315	0.2	■	150	0.05	0.8	-	-	-	■	140	0.05	0.8	-	-	-	-	-	-
	T8330	0.2	■	145	0.05	0.8	-	-	-	■	135	0.05	0.8	-	-	-	-	-	-
	T8430	0.2	■	190	0.05	0.8	-	-	-	■	155	0.05	0.8	-	-	-	-	-	-
VCGT 070204E-FF2	T8315	0.4	■	125	0.12	0.8	-	-	-	■	115	0.12	0.8	-	-	-	-	-	-
	T8330	0.4	■	120	0.12	0.8	-	-	-	■	110	0.12	0.8	-	-	-	-	-	-
	T8430	0.4	■	145	0.12	0.8	-	-	-	■	120	0.12	0.8	-	-	-	-	-	-
VCGT 130302E-FF2	T5315	0.2	■	250	0.05	1.0	-	-	-	■	235	0.05	1.0	-	-	-	-	-	-
	T7325	0.2	■	165	0.05	1.0	-	-	-	-	-	-	-	-	-	-	-	-	-
	T8330	0.2	■	140	0.05	1.0	-	-	-	■	130	0.05	1.0	-	-	-	-	-	-
	T8430	0.2	■	185	0.05	1.0	-	-	-	■	150	0.05	1.0	-	-	-	-	-	-
	T9315	0.2	■	265	0.05	1.0	-	-	-	■	250	0.05	1.0	-	-	-	-	-	-
	T9325	0.2	■	240	0.05	1.0	-	-	-	■	225	0.05	1.0	-	-	-	-	-	-
	TT010	0.2	■	240	0.05	0.5	-	-	-	-	-	-	-	-	-	-	-	-	-



Kesme hızı (vc), ilerleme (f) ve kesme derinliği (ap) için uygunluk ve başlangıç değerleri. Daha ileri hesaplamalar için İşleme Hesaplayıcısı uygulamasına başvurun.

Product	RE (mm)	P			M			K			N			S			H		
		vc (m/min)	f (mm/rev)	ap (mm)	vc (m/min)	f (mm/rev)	ap (mm)	vc (m/min)	f (mm/rev)	ap (mm)	vc (m/min)	f (mm/rev)	ap (mm)	vc (m/min)	f (mm/rev)	ap (mm)	vc (m/min)	f (mm/rev)	ap (mm)

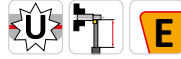
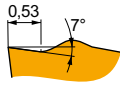

FF2 geometri, ince-finişten finişe işleme kadar için çok pozitif tasarım, darbesizden hafif darbeli işleme kadar uygun.

VCGT 130304E-FF2	T5315	0.4	✓	195	0.12	1.0	–	–	–	■	185	0.12	1.0	–	–	–	–	–	–
	T7325	0.4	✓	135	0.12	1.0	–	–	–	–	–	–	–	–	–	–	–	–	–
	T8330	0.4	■	115	0.12	1.0	–	–	–	■	105	0.12	1.0	–	–	–	–	–	–
	T8430	0.4	■	140	0.12	1.0	–	–	–	✓	115	0.12	1.0	–	–	–	–	–	–
	T9315	0.4	■	195	0.12	1.0	–	–	–	✓	185	0.12	1.0	–	–	–	–	–	–
	T9325	0.4	■	175	0.12	1.0	–	–	–	✓	165	0.12	1.0	–	–	–	–	–	–
TT010	0.4	■	245	0.06	0.5	–	–	–	–	–	–	–	–	–	–	–	–	–	
VCGT 130308E-FF2	T7325	0.8	✓	145	0.17	1.0	–	–	–	–	–	–	–	–	–	–	–	–	
	T9315	0.8	■	200	0.17	1.0	–	–	–	✓	190	0.17	1.0	–	–	–	–	–	
	T9325	0.8	■	180	0.17	1.0	–	–	–	✓	170	0.17	1.0	–	–	–	–	–	
	TT010	0.8	■	245	0.10	0.8	–	–	–	–	–	–	–	–	–	–	–	–	

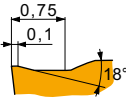

FM2 geometri, finişten orta işleme kadar, ve darbesizden darbeli kesmeye kadar uygun.

VCGT 130308E-FM2	T8330	0.8	■	125	0.17	1.0	✓	75	0.15	1.0	■	115	0.17	1.0	–	–	–	–	–
	T8430	0.8	■	145	0.17	1.0	✓	80	0.15	1.0	✓	120	0.17	1.0	–	–	–	–	–
	T9325	0.8	■	180	0.17	1.0	✓	105	0.15	1.0	✓	170	0.17	1.0	–	–	–	–	–



NF1 geometri, ince finişten yarı kabaya kadar işlemek için pozitif tasarım, darbesiz kesim için uygun.

VCGT 130302E-NF2	H07	0.2	–	–	–	✓	60	0.09	1.0	✓	95	0.10	1.0	✓	310	0.12	1.0	■	30	0.07	0.8	–	–	–		
	T6310	0.2	✓	125	0.07	1.0	■	90	0.06	1.0	✓	100	0.07	1.0	✓	375	0.08	1.0	■	35	0.06	0.8	–	–	–	
	T7325	0.2	✓	150	0.07	1.0	■	115	0.06	1.0	–	–	–	–	–	–	–	–	■	45	0.06	0.8	–	–	–	
	T7335	0.2	✓	150	0.07	1.0	■	115	0.06	1.0	–	–	–	–	–	–	–	–	■	45	0.06	0.8	–	–	–	
	T9315	0.2	✓	200	0.10	1.0	–	–	–	✓	190	0.10	1.0	–	–	–	–	–	–	–	–	–	–	–	–	
	T9325	0.2	✓	210	0.07	1.0	■	125	0.06	1.0	✓	195	0.07	1.0	–	–	–	–	–	✓	45	0.06	0.8	–	–	–
	T9335	0.2	✓	155	0.10	1.0	■	90	0.09	1.0	–	–	–	–	–	–	–	–	✓	30	0.07	0.8	–	–	–	
	TT010	0.2	✓	240	0.05	0.5	✓	140	0.05	0.5	–	–	–	–	–	–	–	–	–	–	–	–	–	–	–	
	VCGT 130304E-NF2	H07	0.4	–	–	–	✓	60	0.11	1.0	✓	95	0.12	1.0	✓	310	0.14	1.0	■	30	0.11	0.8	–	–	–	
		T5315	0.4	✓	195	0.12	1.0	–	–	–	✓	185	0.12	1.0	–	–	–	–	–	–	–	–	–	–	–	
T6310		0.4	✓	115	0.12	1.0	■	80	0.11	1.0	✓	90	0.12	1.0	✓	345	0.14	1.0	■	30	0.11	0.8	–	–	–	
T7325		0.4	✓	135	0.12	1.0	■	105	0.11	1.0	–	–	–	–	–	–	–	–	■	40	0.08	0.8	–	–	–	
T7335		0.4	✓	135	0.12	1.0	■	105	0.11	1.0	–	–	–	–	–	–	–	–	■	40	0.08	0.8	–	–	–	
T9315		0.4	✓	210	0.10	1.0	–	–	–	✓	195	0.10	1.0	–	–	–	–	–	–	–	–	–	–	–	–	
T9325		0.4	✓	175	0.12	1.0	■	105	0.11	1.0	✓	165	0.12	1.0	–	–	–	–	–	✓	35	0.08	0.8	–	–	–
T9335		0.4	✓	150	0.12	1.0	■	90	0.11	1.0	–	–	–	–	–	–	–	–	✓	30	0.11	0.8	–	–	–	
TT010		0.4	✓	245	0.06	0.5	✓	145	0.06	0.5	–	–	–	–	–	–	–	–	–	–	–	–	–	–	–	
VCGT 130308E-NF2		T5315	0.8	✓	205	0.17	1.0	–	–	–	✓	190	0.17	1.0	–	–	–	–	–	–	–	–	–	–	–	
	T6310	0.8	✓	125	0.17	1.0	■	90	0.15	1.0	✓	100	0.17	1.0	✓	375	0.20	1.0	■	35	0.12	0.8	–	–	–	
	T7325	0.8	✓	145	0.17	1.0	■	110	0.15	1.0	–	–	–	–	–	–	–	–	■	45	0.12	0.8	–	–	–	
	T7335	0.8	✓	140	0.17	1.0	■	105	0.15	1.0	–	–	–	–	–	–	–	–	■	45	0.12	0.8	–	–	–	
	T9315	0.8	✓	200	0.17	1.0	–	–	–	✓	190	0.17	1.0	–	–	–	–	–	–	–	–	–	–	–	–	
	T9325	0.8	✓	180	0.17	1.0	■	105	0.15	1.0	✓	170	0.17	1.0	–	–	–	–	–	✓	40	0.12	0.8	–	–	–
	T9335	0.8	✓	155	0.18	1.0	■	90	0.16	1.0	–	–	–	–	–	–	–	–	✓	30	0.16	0.8	–	–	–	
	TT010	0.8	✓	245	0.10	0.8	✓	145	0.09	0.8	–	–	–	–	–	–	–	–	–	–	–	–	–	–	–	



SF3 geometri, inceden finiş işleme kadar işlemek için çok pozitif tasarım, darbesiz kesim için uygun.

VCGT 130301E-SF2	H07	0.1	–	–	–	✓	80	0.05	1.0	–	–	–	✓	405	0.06	1.0	■	40	0.04	0.8	–	–	–
	T6310	0.1	✓	140	0.05	1.0	■	100	0.05	1.0	–	–	–	✓	420	0.06	1.0	■	40	0.04	0.8	–	–



Kesme hızı (vc), ilerleme (f) ve kesme derinliği (ap) için uygunluk ve başlangıç değerleri. Daha ileri hesaplamalar için İşleme Hesaplayıcısı uygulamasına başvurun.

Product	RE (mm)	P			M			K			N			S			H		
		vc (m/min)	f (mm/rev)	ap (mm)	vc (m/min)	f (mm/rev)	ap (mm)	vc (m/min)	f (mm/rev)	ap (mm)	vc (m/min)	f (mm/rev)	ap (mm)	vc (m/min)	f (mm/rev)	ap (mm)	vc (m/min)	f (mm/rev)	ap (mm)

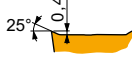

SF3 geometri, inceden finiş işlemeye kadar işlemek için çok pozitif tasarım, darbesiz kesim için uygun.

VCGT 130302E-SF2	H07	0.2	-	-	-	80	0.05	1.0	-	-	-	405	0.06	1.0	40	0.04	0.8	-	-	-
	HF7	0.2	-	-	-	90	0.05	1.0	-	-	-	450	0.06	1.0	-	-	-	-	-	-
	T6310	0.2	140	0.05	1.0	100	0.05	1.0	-	-	-	420	0.06	1.0	40	0.04	0.8	-	-	-
VCGT 130304E-SF2	H07	0.4	-	-	-	65	0.09	1.0	-	-	-	335	0.12	1.0	30	0.07	0.8	-	-	-
	HF7	0.4	-	-	-	75	0.09	1.0	-	-	-	375	0.12	1.0	-	-	-	-	-	-
	T6310	0.4	125	0.10	1.0	90	0.09	1.0	-	-	-	375	0.12	1.0	35	0.07	0.8	-	-	-
VCGT 130308E-SF2	H07	0.8	-	-	-	75	0.09	1.0	-	-	-	390	0.12	1.0	35	0.08	0.8	-	-	-
	HF7	0.8	-	-	-	85	0.09	1.0	-	-	-	435	0.12	1.0	-	-	-	-	-	-
	T6310	0.8	145	0.10	1.0	100	0.09	1.0	-	-	-	435	0.12	1.0	40	0.08	0.8	-	-	-

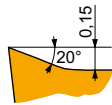

SF3 geometri, inceden finiş işlemeye kadar işlemek için çok pozitif tasarım, darbesiz kesim için uygun.

VCGT 070202E-SF3	H07	0.2	-	-	-	80	0.05	0.8	130	0.05	0.8	415	0.06	0.8	40	0.04	0.6	-	-	-
	T6310	0.2	145	0.05	0.8	100	0.05	0.8	115	0.05	0.8	435	0.06	0.8	40	0.04	0.6	25	0.15	1.0
VCGT 070204E-SF3	T6310	0.4	125	0.10	0.8	90	0.09	0.8	100	0.10	0.8	375	0.12	0.8	35	0.07	0.6	25	0.15	1.0
VCGT 110201E-SF3	T6310	0.1	140	0.05	0.5	100	0.05	0.5	110	0.05	0.5	420	0.06	0.5	40	0.04	0.4	25	0.15	1.0
VCGT 110202E-SF3	H07	0.2	-	-	-	80	0.05	0.8	130	0.05	0.8	415	0.06	0.8	40	0.04	0.6	-	-	-
	T6310	0.2	145	0.05	0.8	100	0.05	0.8	115	0.05	0.8	435	0.06	0.8	40	0.04	0.6	25	0.15	1.0
	T8315	0.2	150	0.05	0.8	90	0.05	0.8	140	0.05	0.8	450	0.06	0.8	35	0.04	0.6	25	0.15	1.0
VCGT 110204E-SF3	H07	0.4	-	-	-	65	0.09	0.8	105	0.10	0.8	335	0.12	0.8	30	0.07	0.6	-	-	-
	T6310	0.4	125	0.10	0.8	90	0.09	0.8	100	0.10	0.8	375	0.12	0.8	35	0.07	0.6	25	0.15	1.0
	T8315	0.4	135	0.10	0.8	80	0.09	0.8	125	0.10	0.8	405	0.12	0.8	30	0.07	0.6	25	0.15	1.0
VCGT 110301E-SF3	T6310	0.1	140	0.05	0.5	100	0.05	0.5	110	0.05	0.5	420	0.06	0.5	40	0.04	0.4	25	0.15	1.0
VCGT 110302E-SF3	T6310	0.2	145	0.05	0.8	100	0.05	0.8	115	0.05	0.8	435	0.06	0.8	40	0.04	0.6	25	0.15	1.0
VCGT 110304E-SF3	T6310	0.4	125	0.10	0.8	90	0.09	0.8	100	0.10	0.8	375	0.12	0.8	35	0.07	0.6	25	0.15	1.0
VCGT 130302E-SF3	H07	0.2	-	-	-	80	0.05	0.8	130	0.05	0.8	415	0.06	0.8	40	0.04	0.6	-	-	-
	T6310	0.2	145	0.05	0.8	100	0.05	0.8	115	0.05	0.8	435	0.06	0.8	40	0.04	0.6	25	0.15	1.0
	T8315	0.2	150	0.05	0.8	90	0.05	0.8	140	0.05	0.8	450	0.06	0.8	35	0.04	0.6	25	0.15	1.0
VCGT 130304E-SF3	H07	0.4	-	-	-	65	0.09	1.0	105	0.10	1.0	335	0.12	1.0	30	0.07	0.8	-	-	-
	T6310	0.4	125	0.10	1.0	90	0.09	1.0	100	0.10	1.0	375	0.12	1.0	35	0.07	0.8	25	0.15	1.0
	T8315	0.4	130	0.10	1.0	75	0.09	1.0	120	0.10	1.0	390	0.12	1.0	30	0.07	0.8	25	0.15	1.0
VCGT 130308E-SF3	H07	0.8	-	-	-	75	0.09	1.0	120	0.10	1.0	390	0.12	1.0	35	0.08	0.8	-	-	-
	T6310	0.8	145	0.10	1.0	100	0.09	1.0	115	0.10	1.0	435	0.12	1.0	40	0.08	0.8	25	0.15	1.0
	T8315	0.8	155	0.10	1.0	90	0.09	1.0	145	0.10	1.0	465	0.12	1.0	35	0.08	0.8	30	0.15	1.0
VCGT 160402E-SF3	T6310	0.2	145	0.05	0.8	100	0.05	0.8	115	0.05	0.8	435	0.06	0.8	40	0.04	0.6	25	0.15	1.0
VCGT 160404E-SF3	H07	0.4	-	-	-	65	0.09	1.0	105	0.10	1.0	335	0.12	1.0	30	0.07	0.8	-	-	-
	T6310	0.4	125	0.10	1.0	90	0.09	1.0	100	0.10	1.0	375	0.12	1.0	35	0.07	0.8	25	0.15	1.0
	T8315	0.4	130	0.10	1.0	75	0.09	1.0	120	0.10	1.0	390	0.12	1.0	30	0.07	0.8	25	0.15	1.0
VCGT 160408E-SF3	H07	0.8	-	-	-	75	0.09	1.2	120	0.10	1.2	390	0.12	1.2	35	0.08	1.0	-	-	-
	T6310	0.8	145	0.10	1.2	100	0.09	1.2	115	0.10	1.2	435	0.12	1.2	40	0.08	1.0	25	0.15	1.0
	T8315	0.8	155	0.10	1.2	90	0.09	1.2	145	0.10	1.2	465	0.12	1.2	35	0.08	1.0	30	0.15	1.0
VCGT 160412E-SF3	H07	1.2	-	-	-	60	0.18	1.2	95	0.20	1.2	310	0.24	1.2	30	0.14	1.0	-	-	-
	T6310	1.2	125	0.20	1.2	90	0.18	1.2	100	0.20	1.2	375	0.24	1.2	35	0.14	1.0	25	0.15	1.0



Kesme hızı (vc), ilerleme (f) ve kesme derinliği (ap) için uygunluk ve başlangıç değerleri. Daha ileri hesaplamalar için İşleme Hesaplayıcısı uygulamasına başvurun.

Product	RE (mm)	P			M			K			N			S			H		
		vc (m/min)	f (mm/rev)	ap (mm)	vc (m/min)	f (mm/rev)	ap (mm)	vc (m/min)	f (mm/rev)	ap (mm)	vc (m/min)	f (mm/rev)	ap (mm)	vc (m/min)	f (mm/rev)	ap (mm)	vc (m/min)	f (mm/rev)	ap (mm)

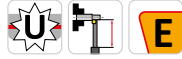
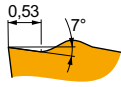

FL-FF2 sol kesme yönlü geometri, ince-finişten finişe işleme kadar için çok pozitif tasarım, darbesizden hafif darbeleri işleme kadar uygun.

VCGX 130300FL-FF2	T6310	0.0	140	0.05	1.0	—	—	—	110	0.05	1.0	—	—	—	—	—	—	—
	T8315	0.0	150	0.05	1.0	—	—	—	140	0.05	1.0	—	—	—	—	—	—	—
	TT010	0.0	240	0.05	0.5	—	—	—	—	—	—	—	—	—	—	—	—	—
VCGX 130301FL-FF2	T6310	0.1	140	0.05	1.0	—	—	—	110	0.05	1.0	—	—	—	—	—	—	—
	T8315	0.1	150	0.05	1.0	—	—	—	140	0.05	1.0	—	—	—	—	—	—	—

VCMT



	IC (mm)	D1 (mm)	L (mm)	S (mm)
1103	6.350	2.80	11.10	3.18
1604	9.525	4.40	16.60	4.76

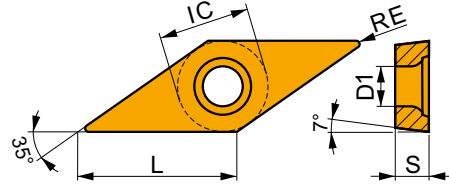

Kesme hızı (vc), ilerleme (f) ve kesme derinliği (ap) için uygunluk ve başlangıç değerleri. Daha ileri hesaplamalar için İşleme Hesaplayıcısı uygulamasına başvurun.

Product	RE (mm)	P			M			K			N			S			H		
		vc (m/min)	f (mm/rev)	ap (mm)	vc (m/min)	f (mm/rev)	ap (mm)	vc (m/min)	f (mm/rev)	ap (mm)	vc (m/min)	f (mm/rev)	ap (mm)	vc (m/min)	f (mm/rev)	ap (mm)	vc (m/min)	f (mm/rev)	ap (mm)

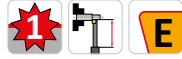
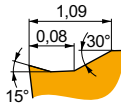

FM geometri, finişten yarı kaba işleme, ve darbesizden hafif darbeleri kesmeye kadar uygun.

VCMT 160404E-FM	T7325	0.4	125	0.19	1.2	95	0.17	1.2	—	—	—	—	—	—	—	—	—	—
	T8330	0.4	130	0.12	1.2	75	0.11	1.2	120	0.12	1.2	390	0.14	1.2	—	—	—	—
	T8430	0.4	150	0.12	1.2	80	0.11	1.2	125	0.12	1.2	420	0.14	1.2	—	—	—	—
	T9315	0.4	210	0.12	1.2	—	—	—	195	0.12	1.2	—	—	—	—	—	—	—
VCMT 160408E-FM	T9325	0.4	155	0.19	1.2	90	0.17	1.2	145	0.19	1.2	—	—	—	—	—	—	—
	T7325	0.8	155	0.17	1.2	120	0.15	1.2	—	—	—	—	—	—	—	—	—	—
	T8330	0.8	135	0.17	1.2	80	0.15	1.2	125	0.17	1.2	405	0.20	1.2	—	—	—	—
	T8430	0.8	155	0.17	1.2	85	0.15	1.2	130	0.17	1.2	435	0.20	1.2	—	—	—	—
	T9315	0.8	220	0.17	1.2	—	—	—	205	0.17	1.2	—	—	—	—	—	—	—
T9325	0.8	195	0.17	1.2	115	0.15	1.2	185	0.17	1.2	—	—	—	—	—	—	—	—

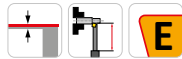
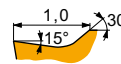

UR geometri, inceden finişe kadar işleme için, ve darbesiz ve hafif darbeleri kesim.

VCMT 110304E-UR	T7325	0.4	110	0.19	0.8	85	0.17	0.8	—	—	—	—	—	—	—	—	—	—
	T8330	0.4	110	0.12	0.8	65	0.11	0.8	100	0.12	0.8	—	—	—	—	—	—	—
	T8430	0.4	135	0.12	0.8	75	0.11	0.8	110	0.12	0.8	—	—	—	—	—	—	—
	T9315	0.4	190	0.12	0.8	—	—	—	180	0.12	0.8	—	—	—	—	—	—	—
	T9325	0.4	140	0.19	0.8	80	0.17	0.8	130	0.19	0.8	—	—	—	—	—	—	—
VCMT 110308E-UR	T7325	0.8	140	0.17	0.8	105	0.15	0.8	—	—	—	—	—	—	—	—	—	—
	T8330	0.8	125	0.17	0.8	75	0.15	0.8	115	0.17	0.8	—	—	—	—	—	—	—
	T8430	0.8	140	0.17	0.8	75	0.15	0.8	115	0.17	0.8	—	—	—	—	—	—	—
	T9315	0.8	195	0.17	0.8	—	—	—	185	0.17	0.8	—	—	—	—	—	—	—
	T9325	0.8	175	0.17	0.8	105	0.15	0.8	165	0.17	0.8	—	—	—	—	—	—	—



Kesme hızı (vc), ilerleme (f) ve kesme derinliği (ap) için uygunluk ve başlangıç değerleri. Daha ileri hesaplamalar için İşleme Hesaplayıcısı uygulamasına başvurun.

Product	RE (mm)	P			M			K			N			S			H		
		vc (m/min)	f (mm/rev)	ap (mm)	vc (m/min)	f (mm/rev)	ap (mm)	vc (m/min)	f (mm/rev)	ap (mm)	vc (m/min)	f (mm/rev)	ap (mm)	vc (m/min)	f (mm/rev)	ap (mm)	vc (m/min)	f (mm/rev)	ap (mm)

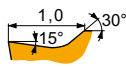
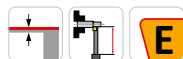

UR geometri, inceden finişe kadar işleme için, ve darbesiz ve hafif darbeli kesim.

VCMT 160404E-UR	T7325	0.4	110	0.19	1.2	85	0.17	1.2	100	0.12	1.2	-	-	-	-	-	-	-	
	T8330	0.4	110	0.12	1.2	65	0.11	1.2	100	0.12	1.2	-	-	-	-	-	-	-	
	T8430	0.4	130	0.12	1.2	70	0.11	1.2	105	0.12	1.2	-	-	-	-	-	-	-	
	T9315	0.4	180	0.12	1.2	-	-	-	170	0.12	1.2	-	-	-	-	-	-	-	-
	T9325	0.4	135	0.19	1.2	80	0.17	1.2	125	0.19	1.2	-	-	-	-	-	-	-	
VCMT 160408E-UR	T7325	0.8	135	0.17	1.2	105	0.15	1.2	-	-	-	-	-	-	-	-	-	-	
	T8330	0.8	115	0.17	1.2	65	0.15	1.2	105	0.17	1.2	-	-	-	-	-	-	-	
	T8430	0.8	135	0.17	1.2	75	0.15	1.2	110	0.17	1.2	-	-	-	-	-	-	-	
	T9315	0.8	190	0.17	1.2	-	-	-	180	0.17	1.2	-	-	-	-	-	-	-	
	T9325	0.8	170	0.17	1.2	100	0.15	1.2	160	0.17	1.2	-	-	-	-	-	-	-	

VCMW

PRAMET

	IC (mm)	D1 (mm)	L (mm)	S (mm)
1103	6.350	2.80	11.10	3.18
1604	9.525	4.40	16.60	4.76

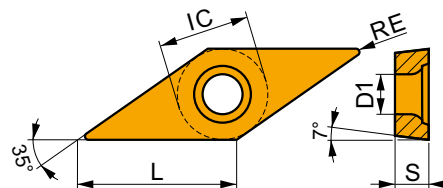

Kesme hızı (vc), ilerleme (f) ve kesme derinliği (ap) için uygunluk ve başlangıç değerleri. Daha ileri hesaplamalar için İşleme Hesaplayıcısı uygulamasına başvurun.

Product	RE (mm)	P			M			K			N			S			H		
		vc (m/min)	f (mm/rev)	ap (mm)	vc (m/min)	f (mm/rev)	ap (mm)	vc (m/min)	f (mm/rev)	ap (mm)	vc (m/min)	f (mm/rev)	ap (mm)	vc (m/min)	f (mm/rev)	ap (mm)	vc (m/min)	f (mm/rev)	ap (mm)

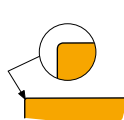

İnce finişten yarı kaba işleme kadar ve darbesizden hafif darbeli kesmeye kadar uygun.

VCMW 110302	T5305	0.2	-	-	-	-	-	-	170	0.08	1.2	-	-	-	-	-	-	35	0.15	1.0
	T5315	0.2	-	-	-	-	-	-	145	0.08	1.2	-	-	-	-	-	-	30	0.15	1.0
	T6310	0.2	-	-	-	-	-	-	70	0.08	1.2	-	-	-	-	-	-	15	0.15	1.0
VCMW 110304	T5305	0.4	-	-	-	-	-	-	165	0.10	1.2	-	-	-	-	-	-	35	0.15	1.0
	T5315	0.4	-	-	-	-	-	-	145	0.10	1.2	-	-	-	-	-	-	30	0.15	1.0
	T6310	0.4	-	-	-	-	-	-	70	0.10	1.2	-	-	-	-	-	-	15	0.15	1.0
VCMW 160404	T5305	0.4	-	-	-	-	-	-	165	0.10	1.5	-	-	-	-	-	-	35	0.15	1.0
	T5315	0.4	-	-	-	-	-	-	140	0.10	1.5	-	-	-	-	-	-	30	0.15	1.0
	T6310	0.4	-	-	-	-	-	-	70	0.10	1.5	-	-	-	-	-	-	15	0.15	1.0
VCMW 160408	T5305	0.8	-	-	-	-	-	-	155	0.18	1.5	-	-	-	-	-	-	30	0.15	1.0
	T5315	0.8	-	-	-	-	-	-	135	0.18	1.5	-	-	-	-	-	-	25	0.15	1.0
	T6310	0.8	-	-	-	-	-	-	70	0.18	1.5	-	-	-	-	-	-	15	0.15	1.0



VCMW PCD



	IC	D1	L	S
	(mm)	(mm)	(mm)	(mm)
1604	9.525	4.40	16.60	4.76

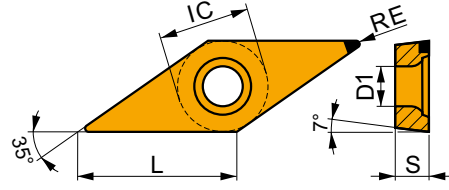

Kesme hızı (vc), ilerleme (f) ve kesme derinliği (ap) için uygunluk ve başlangıç değerleri. Daha ileri hesaplamalar için İşleme Hesaplayıcısı uygulamasına başvurun.

Product	RE (mm)	P			M			K			N			S			H		
		vc (m/min)	f (mm/rev)	ap (mm)	vc (m/min)	f (mm/rev)	ap (mm)	vc (m/min)	f (mm/rev)	ap (mm)	vc (m/min)	f (mm/rev)	ap (mm)	vc (m/min)	f (mm/rev)	ap (mm)	vc (m/min)	f (mm/rev)	ap (mm)

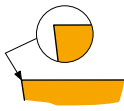

PCD lehimli, finiştten orta kaba işlemeye kadar, yüksek hızlar ve stabil şartlar için uygun.

VCMW 160404FN	PD1	0.4	-	-	-	-	-	-	-	■	900	0.12	0.5	-	-	-	-	-	-
VCMW 160408FN	PD1	0.8	-	-	-	-	-	-	-	■	1050	0.12	1.0	-	-	-	-	-	-



SVAC(RL)-DC EXT



PRAMET

S



VCGX13 Uç için Vida Sıklı 90° Açılı Dış Kater

Vida sıklı Sağ/Sol dış kayar otomat kateri. Pozitif VCGX uçlarla çap, alın, konik, 53°'ye kadar kopya ve pah tormalama için uygundur. 10x10-25x25mm şaft ölçülerinde bulunur. Gövde uzun takım ömrü için işlem görmüştür.

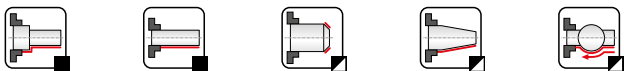
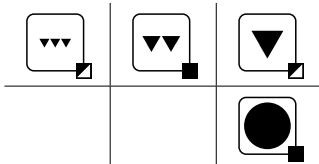
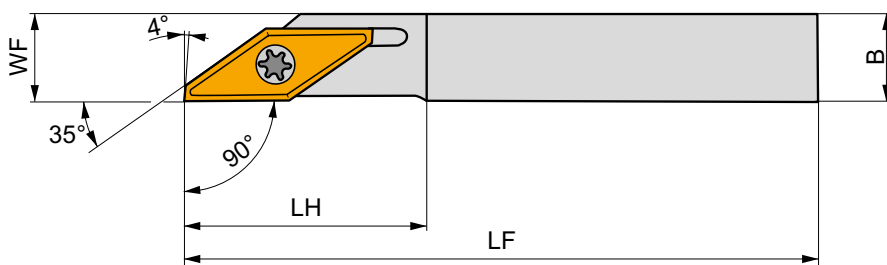
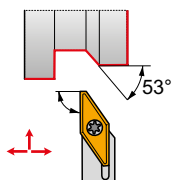

Product	H (mm)	B (mm)	HF (mm)	WF (mm)	LF (mm)	LH (mm)	LAMS (°)	GAMO (°)	kg	GI222	SV20
R SVACR 1010 L 13-DC	10	10	10	10	140	25	0	0	0.12	GI222	SV20
SVACR 1212 L 13-DC	12	12	12	12	140	25	0	0	0.17	GI222	SV20
SVACR 1616 M 13-DC	16	16	16	16	150	25	0	0	0.29	GI222	SV20
SVACR 2020 M 13-DC	20	20	20	20	150	25	0	0	0.46	GI222	SV20
SVACR 2525 M 13-DC	25	25	25	25	150	25	0	0	0.67	GI222	SV20
L SVACL 1010 L 13-DC	10	10	10	10	140	25	0	0	0.10	GI222	SV20
SVACL 1212 L 13-DC	12	12	12	12	140	25	0	0	0.19	GI222	SV20
SVACL 1616 M 13-DC	16	16	16	16	150	25	0	0	0.29	GI222	SV20
SVACL 2020 M 13-DC	20	20	20	20	150	25	0	0	0.43	GI222	SV20
SVACL 2525 M 13-DC	25	25	25	25	150	25	0	0	0.67	GI222	SV20



GI222



VCGX 1303..



SV20



5513 020-24



1.5



M 3



8.5



PT-8002



SVGCL(RL) EXT

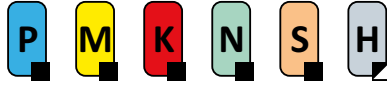

PRAMET

S



VC.. Uç için Vida Sıkmalı 90° Açılı Dış Kater

Vida sıkmalı Sağ/Sol dış kater. Pozitif VC.. 07 uçlarla çap, konik, 53°'ye kadar kopya ve pah tornalama için uygundur. 08x08-16x16mm şaft ölçülerinde bulunur. Gövde uzun takım ömrü için işlem görmüştür.

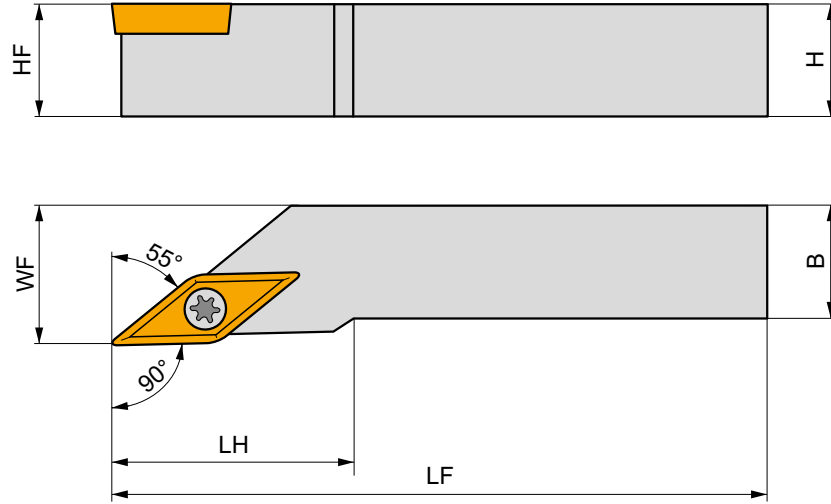
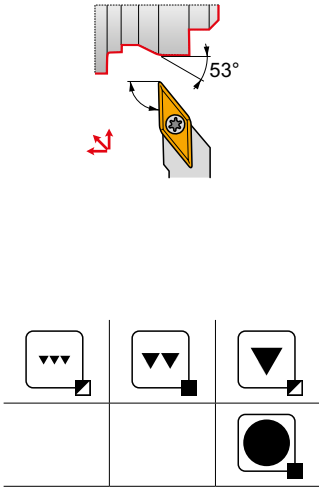

Product	H	B	HF	WF	LF	LH	LAMS	GAMO	kg	GI234	SV23
	(mm)	(mm)	(mm)	(mm)	(mm)	(mm)	(°)	(°)			
R SVGCR 0808 K 07	8	8	8	8.5	125	15	0	0	0.07	GI234	SV23
SVGCR 1010 M 07	10	10	10	10.5	150	15	0	0	0.13	GI234	SV23
SVGCR 1212 M 07	12	12	12	12.5	150	18	0	0	0.17	GI234	SV23
SVGCR 1616 P 07	16	16	16	16.3	170	23	0	0	0.33	GI234	SV23
L SVGCL 0808 K 07	8	8	8	8.5	125	15	0	0	0.07	GI234	SV23
SVGCL 1010 M 07	10	10	10	10.5	150	15	0	0	0.13	GI234	SV23
SVGCL 1212 M 07	12	12	12	12.5	150	18	0	0	0.17	GI234	SV23
SVGCL 1616 P 07	16	16	16	16.3	170	23	0	0	0.33	GI234	SV23



GI234



VC.. 0702..



SV23



DVF 3584



0.6



M 2



5.5



DMD 1650



SVHB(C)(RL) EXT



PRAMET

S



VB/VC.. Uç için Vida Sıklı 107.5° Açılı Dış Kater

Vida sıklı Sağ/Sol dış kater. Pozitif VB/VC.. 11 veya 16 uçlarla çap, alın,konik, 25°'ye kadar kopya ve pah tornalama için uygundur. 16x16-25x25mm şaft ölçülerinde bulunur. Gövde uzun takım ömrü için işlem görmüştür.

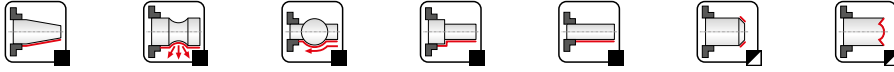
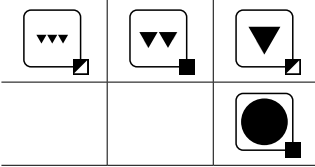
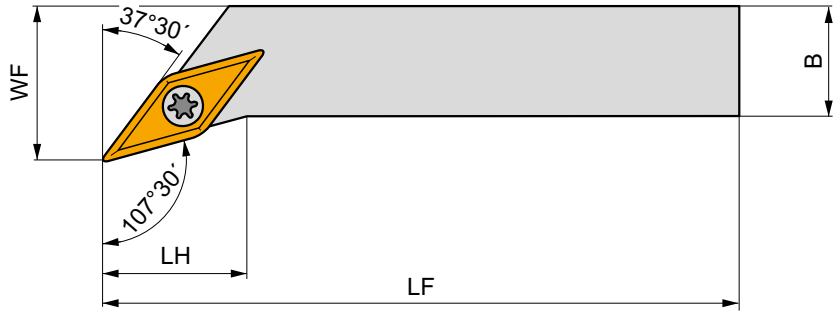
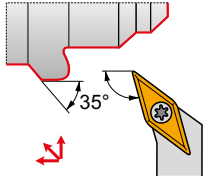

Product	H	B	HF	WF	LF	LH	LAMS	GAMO	kg	G1017	G1194	S01
	(mm)	(mm)	(mm)	(mm)	(mm)	(mm)	(°)	(°)				
R SVHBR 1616 H 11	16	16	16	20	100	14	0	0	0.21	G1194	S01	
SVHCR 2020 K 16-M-A	20	20	20	25	125	20	0	0	0.40	G1017	SV10	
SVHCR 2525 M 16-M-A	25	25	25	32	150	20	0	0	0.68	G1017	SV10	
L SVHBL 1616 H 11	16	16	16	20	100	14	0	0	0.19	G1194	S01	
SVHCL 2020 K 16-M-A	20	20	20	25	125	20	0	0	0.40	G1017	SV10	
SVHCL 2525 M 16-M-A	25	25	25	32	150	20	0	0	0.07	G1017	SV10	

G1017	VB.. 1604..	VC.. 1604..
G1194	VB.. 1103..	VC.. 1103..

		Nm						
S01	US 2506-T07P	0.9	M 2.5	6.3	-	-	FLAGT07P	-
SV10	US 3512-T15P	3.0	M 3.5	12.6	SVN 160304	MS 3510	FLAGT15P	HXK 3.5



SVJB(C)(RL) EXT

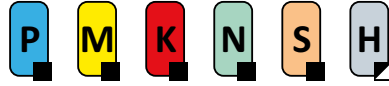

PRAMET

S



VB/VC.. Uç için Vida Sıkmalı 93° Açılı Dış Kater

Vida sıkmalı Sağ/Sol dış kater. Pozitif VB/VC.. 11 veya 16 uçlarla çap, konik, 50°'ye kadar kopya ve pah tormalama için uygundur. 12x12-32x25mm shaft ölçülerinde bulunur. Gövde uzun takım ömrü için işlem görmüştür.

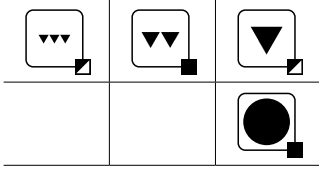
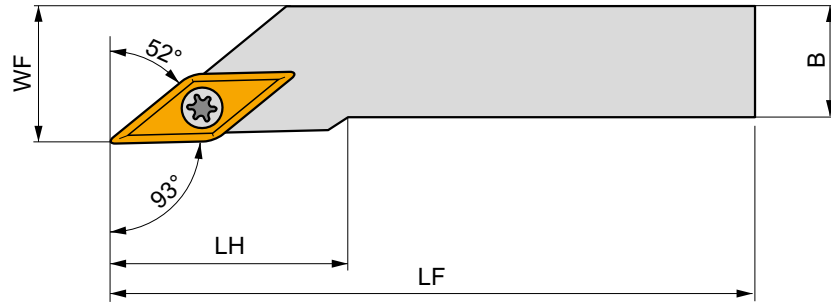
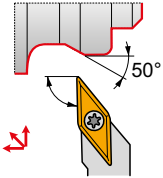

Product	H	B	HF	WF	LF	LH	LAMS	GAMO	kg	GI	SV
	(mm)	(mm)	(mm)	(mm)	(mm)	(mm)	(°)	(°)			
R SVJBR 1212 F 11	12	12	12	16	80	20	0	0	0.09	GI194	S01
SVJBR 1616 H 11	16	16	16	20	100	20	0	0	0.20	GI194	S01
SVJCR 1212 N 13	12	12	12	16	160	27	0	0	0.19	GI211	SV21
SVJCR 1616 H 13	16	16	16	20	100	30	0	0	0.20	GI211	SV21
SVJCR 2020 K 13	20	20	20	25	125	30	0	0	0.37	GI211	SV22
SVJCR 2525 M 13	25	25	25	32	150	30	0	0	0.67	GI211	SV22
SVJCR 2020 K 16-M-A	20	20	20	25	125	28	0	0	0.35	GI017	SV10
SVJCR 2525 M 16-M-A	25	25	25	32	150	32	0	0	0.68	GI017	SV10
SVJCR 3225 P 16-M-A	32	25	32	32	170	32	0	0	0.99	GI017	SV10
L SVJBL 1212 F 11	12	12	12	16	80	20	0	0	0.09	GI194	S01
SVJBL 1616 H 11	16	16	16	20	100	20	0	0	0.19	GI194	S01
SVJCL 1212 N 13	12	12	12	16	160	27	0	0	0.19	GI211	SV21
SVJCL 1616 H 13	16	16	16	20	100	30	0	0	0.20	GI211	SV21
SVJCL 2020 K 13	20	20	20	25	125	30	0	0	0.37	GI211	SV22
SVJCL 2525 M 13	25	25	25	32	150	30	0	0	0.67	GI211	SV22
SVJCL 2020 K 16-M-A	20	20	20	25	125	28	0	0	0.40	GI017	SV10
SVJCL 2525 M 16-M-A	25	25	25	32	150	32	0	0	0.70	GI017	SV10
SVJCL 3225 P 16-M-A	32	25	32	32	170	32	0	0	0.99	GI017	SV10



GI017
GI194
GI211

VB.. 1604..
VB.. 1103..
-

VC.. 1604..
VC.. 1103..
VC.. 1303..



S01
SV10
SV21
SV22

US 2506-T07P
US 3512-T15P
5513 020-24
DVF 0573

0.9
3.0
1.5
1.5

M 2.5
M 3.5
M 3
M 3

6.3
12.6
8.5
10.3

-
SVN 160304
-
DAP 0331

-
MS 3510
-
DVT 0332

FLAG T07P
FLAG T15P
PT-8002
PT-8002

-
HXK 3.5
-
174.1-870



SVJC(RL)-DC EXT



PRAMET

S



VCGX13 Uç için Vida Sıkmalı 93° Açılı Dış Kater

Vida sıkmalı Sağ/Sol dış kayar otomat kateri. Pozitif VCGX uçlarla çap, alın, konik, 50°'ye kadar kopya ve pah tornalama için uygundur. 10x10-25x25mm shaft ölçülerinde bulunur. Gövde uzun takım ömrü için işlem görmüştür.

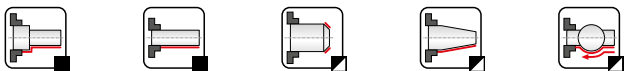
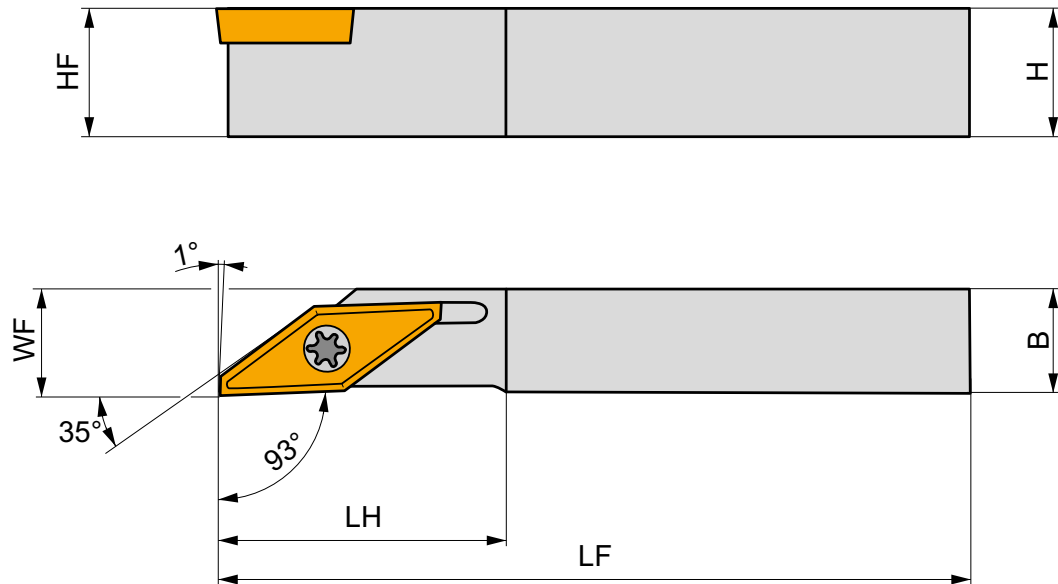
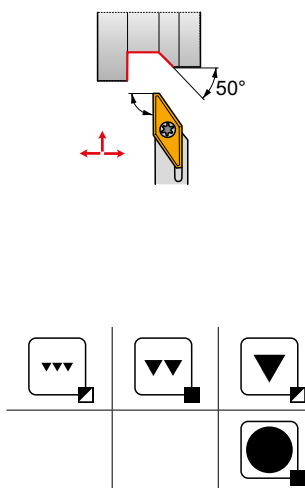

Product	H (mm)	B (mm)	HF (mm)	WF (mm)	LF (mm)	LH (mm)	LAMS (°)	GAM0 (°)	kg	GI222	SV20
R SVJCR 1010 L 13-DC	10	10	10	0	140	25	0	0	0.12	GI222	SV20
SVJCR 1212 L 13-DC	12	12	12	0	140	25	0	0	0.17	GI222	SV20
SVJCR 1616 M 13-DC	16	16	16	0	150	25	0	0	0.29	GI222	SV20
SVJCR 2020 M 13-DC	20	20	20	0	150	25	0	0	0.45	GI222	SV20
SVJCR 2525 M 13-DC	25	25	25	0	150	25	0	0	0.68	GI222	SV20
L SVJCL 1010 L 13-DC	10	10	10	0	140	25	0	0	0.12	GI222	SV20
SVJCL 1212 L 13-DC	12	12	12	0	140	25	0	0	0.17	GI222	SV20
SVJCL 1616 M 13-DC	16	16	16	0	150	25	0	0	0.30	GI222	SV20
SVJCL 2020 M 13-DC	20	20	20	0	150	25	0	0	0.47	GI222	SV20
SVJCL 2525 M 13-DC	25	25	25	0	150	25	0	0	0.69	GI222	SV20



GI222



VCGX 1303..



SV20



5513 020-24



1.5



M 3



8.5



PT-8002



SVPB(C)(RL) EXT



PRAMET

S



VB/VC.. Uç için Vida Sıkmalı 117.5° Açılı Dış Kater

Vida sıkmalı Sağ/Sol dış kater. Pozitif VB/VC.. 11 veya 16 uçlarla çap, alın,konik, 25°'ye kadar kopya ve pah tornalama için uygundur. 16x16-32x25mm şaft ölçülerinde bulunur. Gövde uzun takım ömrü için işlem görmüştür.

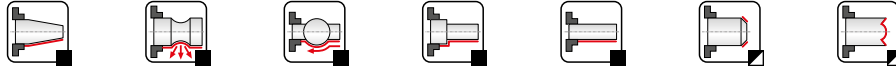
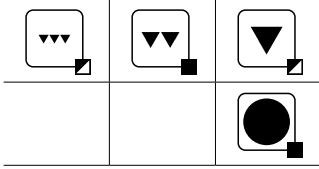
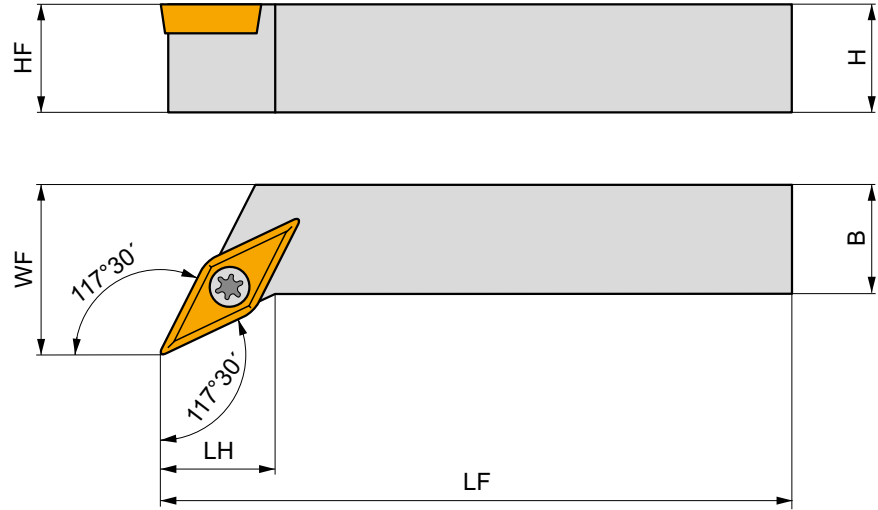
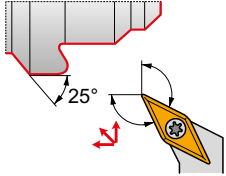

Product	H	B	HF	WF	LF	LH	LAMS	GAMO	kg	GI	SV
	(mm)	(mm)	(mm)	(mm)	(mm)	(mm)	(°)	(°)			
R SVPBR 1616 H 11	16	16	16	20	100	12	0	0	0.20	GI194	S01
SVPBR 2020 K 11	20	20	20	25	125	12	0	0	0.41	GI194	S01
SVPCR 2020 K 16-M-A	20	20	20	25	125	20	0	0	0.40	GI017	SV10
SVPCR 2525 M 16-M-A	25	25	25	32	150	25	0	0	0.75	GI017	SV10
SVPCR 3225 P 16-M-A	32	25	32	32	170	25	0	0	1.10	GI017	SV10
L SVPBL 1616 H 11	16	16	16	20	100	12	0	0	0.20	GI194	S01
SVPBL 2020 K 11	20	20	20	25	125	12	0	0	0.39	GI194	S01
SVPCL 2020 K 16-M-A	20	20	20	25	125	20	0	0	0.70	GI017	SV10
SVPCL 2525 M 16-M-A	25	25	25	32	150	25	0	0	0.70	GI017	SV10
SVPCL 3225 P 16-M-A	32	25	32	32	170	25	0	0	1.10	GI017	SV10

GI	VB..	VC..
GI017	VB.. 1604..	VC.. 1604..
GI194	VB.. 1103..	VC.. 1103..

SV	US	Nm	M	mm	mm	mm	mm	mm
S01	US 2506-T07P	0.9	M 2.5	6.3	-	-	FLAG T07P	-
SV10	US 3512-T15P	3.0	M 3.5	12.6	SVN 160304	MS 3510	FLAG T15P	HXK 3.5



SVVB(C)N EXT

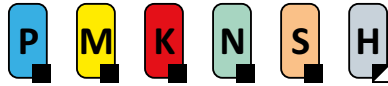

PRAMET



VB/VC.. Uç için Vida Sıklı 72.5° Açılı Dış Kater

Vida sıklı nötr dış kater. Pozitif VB/VC.. 11 ve 16 uçlarla çap, 72.5°'ye kadar kopya, konik ve pah tornalama için uygundur. 12x12-32x25mm mevcuttur. Gövde uzun takım ömrü için işlem görmüştür.

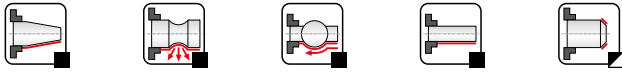
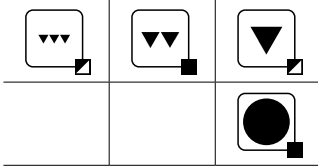
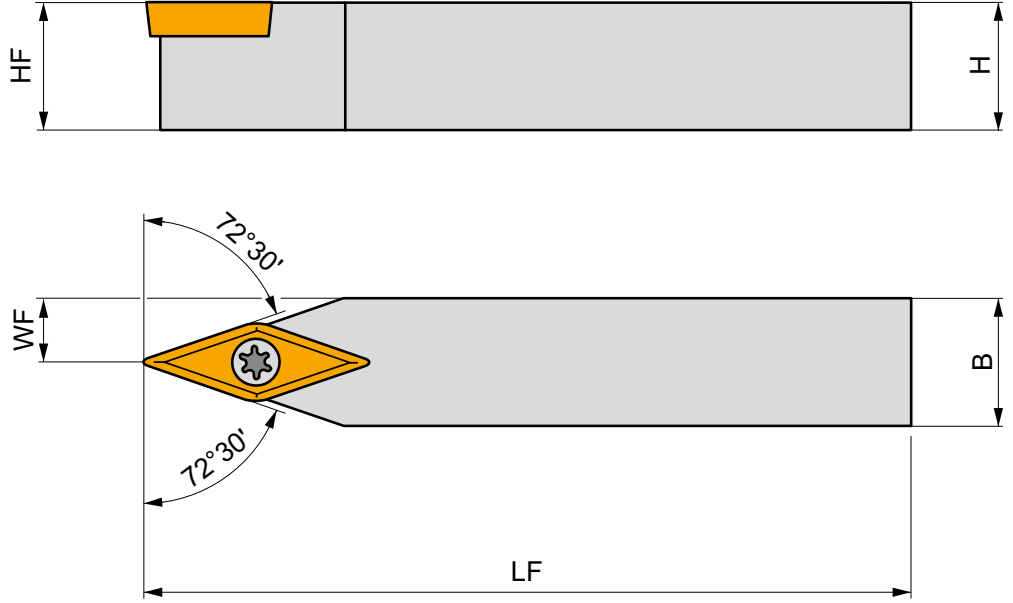
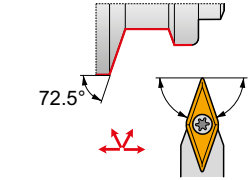

Product	H (mm)	B (mm)	HF (mm)	WF (mm)	LF (mm)	LH (mm)	LAMS (°)	GAMO (°)	kg	GI	SV
N SVVBN 1212 F 11	12	12	12	6	80	-	0	0	0.11	GI194	S01
SVVBN 1616 H 11	16	16	16	8	100	-	0	0	0.18	GI194	S01
SVVBN 2020 K 11	20	20	20	10	125	-	0	0	0.38	GI194	S01
SVVCN 1212 N 13	12	12	12	6	160	-	0	0	0.19	GI211	SV21
SVVCN 1616 H 13	16	16	16	8	100	-	0	0	0.20	GI211	SV21
SVVCN 2020 K 13	20	20	20	10	125	-	0	0	0.36	GI211	SV22
SVVCN 2525 M 13	25	25	25	12.5	150	-	0	0	0.66	GI211	SV22
SVVCN 2020 K 16-M-A	20	20	20	10	125	-	0	0	0.34	GI017	SV10
SVVCN 2525 M 16-M-A	25	25	25	12.5	150	-	0	0	0.68	GI017	SV10
SVVCN 3225 P 16-M-A	32	25	32	12.5	170	-	0	0	0.98	GI017	SV10

GI	VB..	VC..
GI017	VB.. 1604..	VC.. 1604..
GI194	VB.. 1103..	VC.. 1103..
GI211	-	VC.. 1303..

SV	US	Nm	M	mm	SVN	MS	PT	HXX
S01	US 2506-T07P	0.9	M 2.5	6.3	-	-	FLAG T07P	-
SV10	US 3512-T15P	3.0	M 3.5	12.6	SVN 160304	MS 3510	FLAG T15P	HXX 3.5
SV21	5513 020-24	1.5	M 3	8.5	-	-	PT-8002	-
SV22	DVF 0573	1.5	M 3	10.3	DAP 0331	DVT 0332	PT-8002	174.1-870



SVXB(C)(RL) EXT

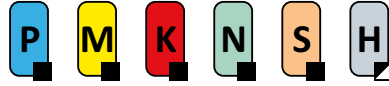

PRAMET

S



VB/VC.. Uç için Vida Sıkmalı 98/113° Açılı Dış Kater

Vida sıkmalı Sağ/Sol dış kater. Pozitif VB/VC.. 11 veya 16 uçlarla çap, konik, 30°'ye kadar kopya ve pah tornalama için uygundur. 12x12-32x25mm shaft ölçülerinde bulunur. Gövde uzun takım ömrü için işlem görmüştür.

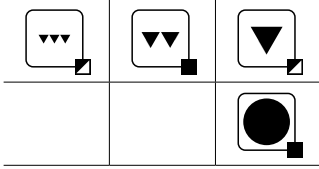
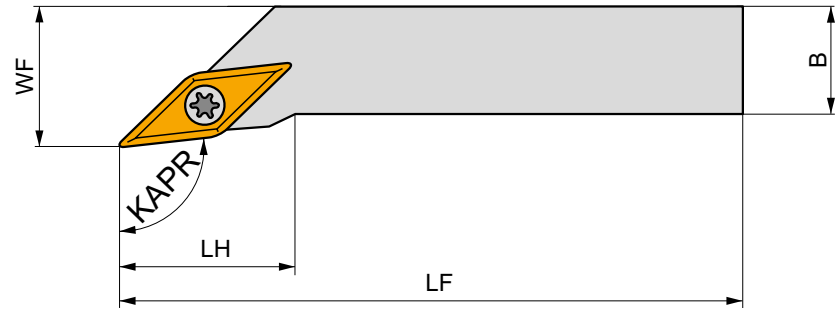
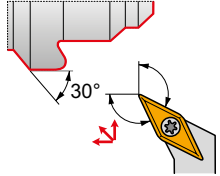

Product	H	B	HF	WF	LF	LH	KAPR	LAMS	GAMO	kg	GI	SV
	(mm)	(mm)	(mm)	(mm)	(mm)	(mm)	(°)	(°)	(°)			
R SVXBR 1212 F 11	12	12	12	16	80	20	98	0	0	0.09	GI194	SO1
SVXBR 1616 H 11	16	16	16	20	100	14	98	0	0	0.19	GI194	SO1
SVXCR 2020 K 13	20	20	20	25	125	12	113	0	0	0.38	GI211	SV22
SVXCR 2020 K 16-M-A	20	20	20	25	125	28	98	0	0	0.41	GI017	SV10
SVXCR 2525 M 16-M-A	25	25	25	32	150	32	98	0	0	0.68	GI017	SV10
SVXCR 3225 P 16-M-A	32	25	32	32	170	32	98	0	0	1.00	GI017	SV10
L SVXBL 1212 F 11	12	12	12	16	80	20	98	0	0	0.09	GI194	SO1
SVXBL 1616 H 11	16	16	16	20	100	14	98	0	0	0.19	GI194	SO1
SVXCL 2020 K 13	20	20	20	25	125	12	113	0	0	0.38	GI211	SV22
SVXCL 2020 K 16-M-A	20	20	20	25	125	28	98	0	0	0.38	GI017	SV10
SVXCL 2525 M 16-M-A	25	25	25	32	150	32	98	0	0	0.69	GI017	SV10
SVXCL 3225 P 16-M-A	32	25	32	32	170	32	98	0	0	0.99	GI017	SV10

GI	VB..	VC..
GI017	VB.. 1604..	VC.. 1604..
GI194	VB.. 1103..	VC.. 1103..
GI211	-	VC.. 1303..

SV	US	Nm	M	mm	mm	mm	mm	mm	mm
SO1	US 2506-T07P	0.9	M 2.5	6.3	-	-	FLAG T07P	-	-
SV10	US 3512-T15P	3.0	M 3.5	12.6	SVN 160304	MS 3510	FLAG T15P	HXK 3.5	-
SV22	DVF 0573	1.5	M 3	10.3	DAP 0331	DVT 0332	PT-8002	174.1-870	-

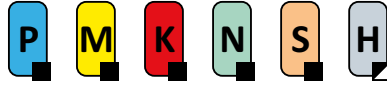
**NEW****C.-SVHB(RL) EXT**

PRAMET

S**VB/VC.. Uç için Vida Sıkmalı, 107.5° Açılı Hızlı Değişirme Dış Takımı**

Vida sıkmalı Sağ/Sol, içten su vermeli dış kater. Pozitif VB/VC.. 16 uçlarla çap,konik, 35°'ye kadar kopya ve pah tornalama için uygundur. PSC C4-C6 ölçülerinde bulunur. Gövde uzun takım ömrü için işlem görmüştür.

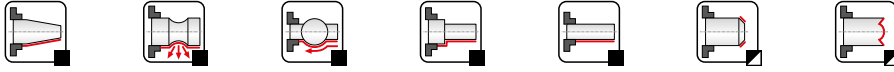
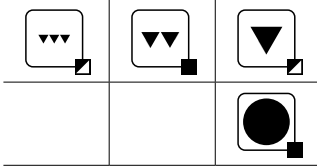
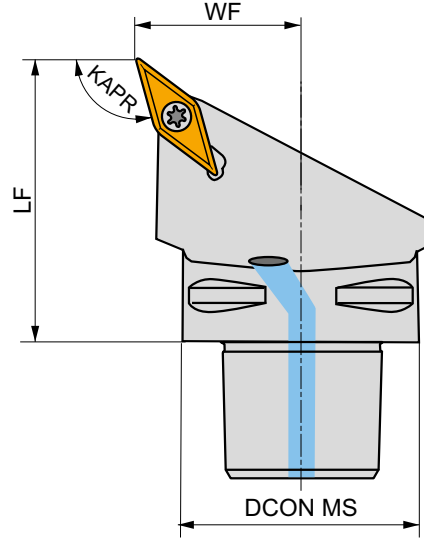
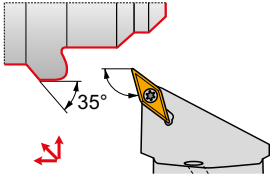

Product	DCON MS (mm)	WF (mm)	LF (mm)	KAPR (°)	LAMS (°)	GAMO (°)		kg			
R	C4-SVHBR-27050-16	40	27	50	107.5	0	0	✓	0.35	GI017	C-SV16S-1
	C5-SVHBR-35060-16	50	35	60	107.5	0	0	✓	0.64	GI017	C-SV16S-2
	C6-SVHBR-45065-16	63	45	65	107.5	0	0	✓	1.13	GI017	C-SV16S-2
L	C4-SVHBL-27050-16	40	27	50	107.5	0	0	✓	0.35	GI017	C-SV16S-1
	C5-SVHBL-35060-16	50	35	60	107.5	0	0	✓	0.64	GI017	C-SV16S-2
	C6-SVHBL-45065-16	63	45	65	107.5	0	0	✓	1.12	GI017	C-SV16S-2



GI017



VB.. 1604..



VC.. 1604..



C-SV16S-1	US 2001-T15P	3.0	M 3.5	12.1	SVS 270-01	MS 9001	FLAGT15P/3,5	CN 034-01
C-SV16S-2	US 2001-T15P	3.0	M 3.5	12.1	SVS 270-01	MS 9001	FLAGT15P/3,5	CN 034-02



NEW

C.-SVJB(RL) EXT



PRAMET

S

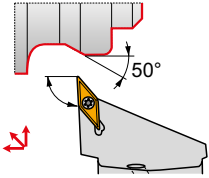

VB/VC.. Uç için Vida Sıkmalı, 93° Açılı Hızlı Değişirme Dış Takımı

Vida sıkmalı Sağ/Sol, içten su vermeli dış kater. Pozitif VB/VC.. 11 veya 16 uçlarla çap, konik, 50°'ye kadar kopya ve pah tornalama için uygundur. PSC C3-C6 ölçülerinde bulunur. Gövde uzun takım ömrü için işlem görmüştür.

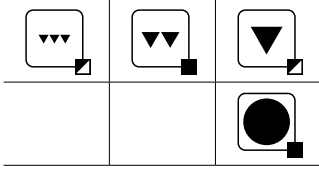
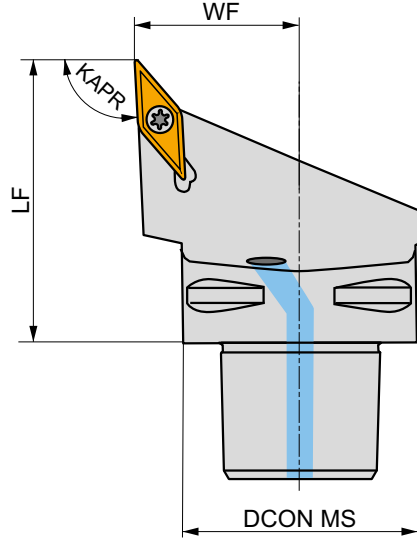

Product	DCON MS (mm)	WF (mm)	LF (mm)	KAPR (°)	LAMS (°)	GAMO (°)		kg		
R C3-SVJBR-22040-11-B1	32	22	40	93	0	0	✓	0.17	GI194	C-SV11
C4-SVJBR-27050-11-B1	40	27	50	93	0	0	✓	0.34	GI194	C-SV11
C4-SVJBR-27050-16	40	27	50	93	0	0	✓	0.35	GI017	C-SV16S-1
C5-SVJBR-35060-16	50	35	60	93	0	0	✓	0.63	GI017	C-SV16S-2
C6-SVJBR-45065-16	63	45	65	93	0	0	✓	1.11	GI017	C-SV16S-2
L C4-SVJBL-27050-16	40	27	50	93	0	0	✓	0.35	GI017	C-SV16S-1
C5-SVJBL-35060-16	50	35	60	93	0	0	✓	0.64	GI017	C-SV16S-2
C6-SVJBL-45065-16	63	45	65	93	0	0	✓	1.11	GI017	C-SV16S-2

GI017	VB.. 1604..	VC.. 1604..
GI194	VB.. 1103..	VC.. 1103..

		Nm						
C-SV11	US 2003-T07P	0.8	M 2.5	6.5	-	-	FLAG T07P	CN 034-01
C-SV16S-1	US 2001-T15P	3.0	M 3.5	12.1	SVS 270-01	MS 9001	FLAG T15P/3,5	CN 034-01
C-SV16S-2	US 2001-T15P	3.0	M 3.5	12.1	SVS 270-01	MS 9001	FLAG T15P/3,5	CN 034-02

NEW
C-SVBN EXT

PRAMET
S

Vida Sıkmalı VB/VC.. Uç için PSC Hızlı Değişirme 72.5° Dış Kateri

Vida sıkmalı, içten su vermeli nötr dış kater. Pozitif VB/VC.. 16 uçlarla çap, 72.5°'ye kadar kopya, konik ve pah tornalamak için uygundur. C4'ten C6'ya kadar PSC şaftlı mevcuttur. Tutucu uzun takım ömrü için işlem görmüştür.

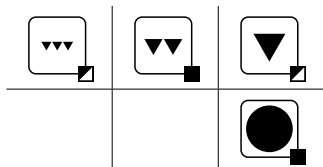
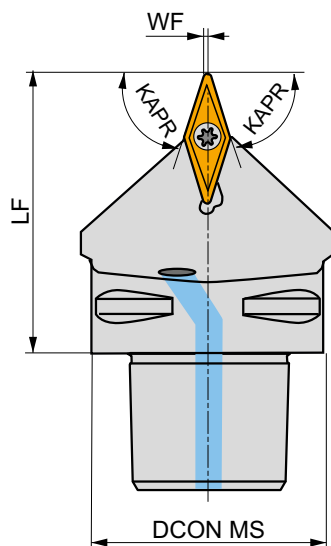
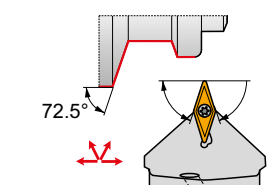

Product	DCON MS (mm)	WF (mm)	LF (mm)	KAPR (°)	LAMS (°)	GAMO (°)				
N C4-SVBN-00050-16	40	0.6	50	72.5	0	0	✓	0.32	GI017	C-SV16S-1
C5-SVBN-00060-16	50	0.6	60	72.5	0	0	✓	0.56	GI017	C-SV16S-2
C6-SVBN-00065-16	63	0.6	65	72.5	0	0	✓	0.99	GI017	C-SV16S-2

GI017	VB.. 1604..	VC.. 1604..

C-SV16S-1	US 2001-T15P	3.0	M 3.5	12.1	SVS 270-01	MS 9001	FLAG T15P/3,5	CN 034-01
C-SV16S-2	US 2001-T15P	3.0	M 3.5	12.1	SVS 270-01	MS 9001	FLAG T15P/3,5	CN 034-02



SVJB(RL) INT



PRAMET

S



VB/VC.. Uç için Vida Sıkmalı 93° Açılı Delik Kateri

Vida sıkmalı Sağ/Sol 93° içten su vermeli delik kateri. Pozitif VB/VC.. 11 uçlarla minimum Ø25mm çap, ve 50°'ye kadar kopya tornalama için uygundur. Ø20 ve Ø25mm shaft ölçülerinde bulunur. Gövde uzun takım ömrü için işlem görmüştür.

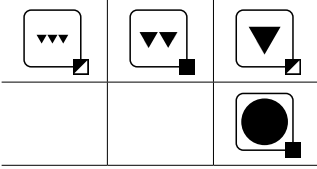
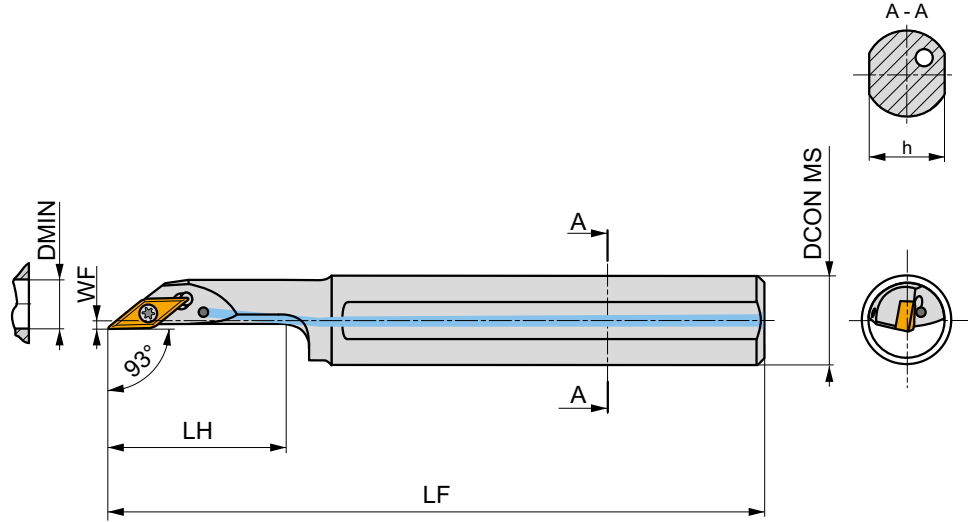
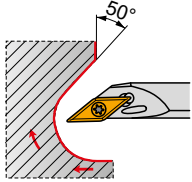

Product	DCON MS (mm)	DMIN (mm)	WF (mm)	H (mm)	LF (mm)	LH (mm)	LAMS (°)	GAMO (°)		kg		
R A20R-SVJBR 11	20	25	2	18	200	40	-5	-5	✓	0.44	GI194	S07
A25S-SVJBR 11	25	32	3.5	23	250	50	-5	-5	✓	0.82	GI194	S07
L A20R-SVJBL 11	20	25	2	18	200	40	-5	-5	✓	0.42	GI194	S07
A25S-SVJBL 11	25	32	3.5	23	250	50	-5	-5	✓	0.82	GI194	S07



GI194



VB.. 1103..



VC.. 1103..



S07



US 2506-T07P



0.9



M 2.5



6.3



FLAG T07P



SVLC(RL) INT



PRAMET

S



VC.. Uç için Vida Sıkmalı 50° Açılı Delik Kateri

Vida sıkmalı Sağ/Sol 50° içten su vermeli delik kateri. Pozitif VC.. 13 uçlarla minimum Ø27mm çap, ve 48°'ye kadar kopya tormalama için uygundur. Ø20-32mm shaft ölçülerinde bulunur. Gövde uzun takım ömrü için işlem görmüştür.

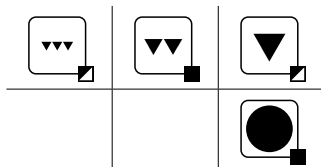
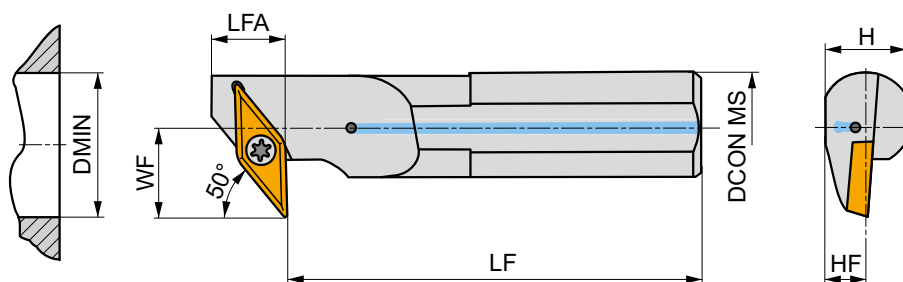
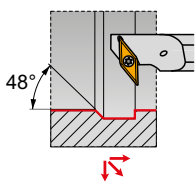

Product	DCON MS	DMIN	WF	H	LF	HF	LFA	LAMS	GAMO		kg		
	(mm)	(mm)	(mm)	(mm)	(mm)	(mm)	(mm)	(°)	(°)				
R	A20S-SVLCR 13-X	20	27	15	18	250	9	15	-4	-2	✓	0.57	GI211 SV21
	A25T-SVLCR 13-X	25	35	20	24	300	12	18	-2	-2	✓	1.01	GI211 SV22
	A32T-SVLCR 13-X	32	43	25	30	300	15	18	-1	-2	✓	1.75	GI211 SV22
L	A20S-SVLCR 13-X	20	27	15	18	250	9	15	-4	-2	✓	0.57	GI211 SV21
	A25T-SVLCR 13-X	25	35	20	24	300	12	18	-2	-2	✓	0.05	GI211 SV22
	A32T-SVLCR 13-X	32	43	25	30	300	15	18	-1	-2	✓	1.75	GI211 SV22



GI211



VC.. 1303..



SV21



5513 020-24



1.5



M3



8.5



-



-



PT-8002



-

SV22

DVF 0573

1.5

M3

10.3

DAP 0331

DVT 0332

PT-8002

174.1-870



SVQB(C)(RL) INT



PRAMET

S



VB/VC.. Uç için Vida Sıkmalı 107.5° Açılı Delik Kateri

Vida sıkmalı Sağ/Sol 107.5° içten su vermeli delik kateri. Pozitif VB/VC.. 11 veya 16 uçlarla minimum Ø20mm çap ve birçok uygulama için uygundur. Ø16-40mm şaft ölçülerinde bulunur. Gövde uzun takım ömrü için işlem görmüştür.

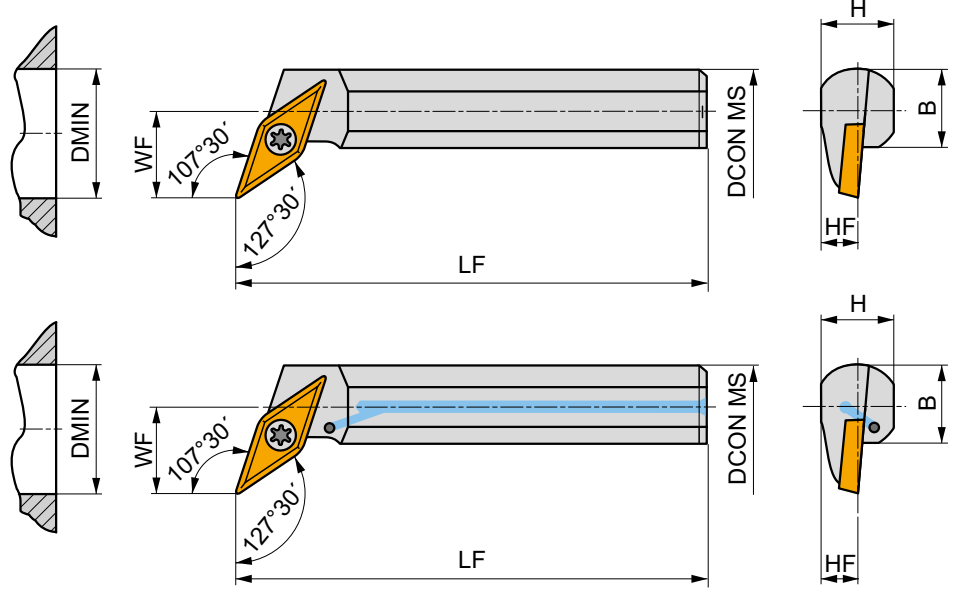
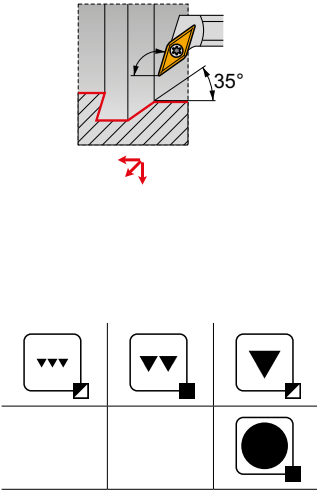

Product	DCON MS	DMIN	WF	H	B	LF	LAMS	GAMO		kg			
	(mm)	(mm)	(mm)	(mm)	(mm)	(mm)	(°)	(°)					
R	A16R-SVQBR 11	16	20	11	14.5	15	200	-5	0	✓	0.33	GI194	S01
	A20S-SVQBR 11	20	25	13	18	18.5	250	-4	0	✓	0.58	GI194	S01
	A16R-SVQCR 13	16	21	11	15	15	200	-6	0	✓	0.30	GI211	SV21
	A20S-SVQCR 13	20	25	13	18	18.5	250	-4	0	✓	0.12	GI211	SV21
	S25T-SVQCR 16	25	32	17	23	23	300	-7	0	-	1.10	GI017	S08
	S32U-SVQCR 16	32	40	22	30	30	350	-5	0	-	2.07	GI017	S08
	S40V-SVQCR 16-A	40	50	27	38	38	400	-5	0	-	3.80	GI017	SV10
L	A16R-SVQBL 11	16	20	11	14.5	15	200	-5	0	✓	0.33	GI194	S01
	A20S-SVQBL 11	20	25	13	18	18.5	250	-4	0	✓	0.58	GI194	S01
	A16R-SVQCL 13	16	21	11	15	15	200	-6	0	✓	0.29	GI211	SV21
	A20S-SVQCL 13	20	25	13	18	18.5	250	-4	0	✓	0.54	GI211	SV21
	S25T-SVQCL 16	25	32	17	23	23	300	-7	0	-	1.09	GI017	S08
	S32U-SVQCL 16	32	40	22	30	30	350	-5	0	-	2.07	GI017	S08
	S40V-SVQCL 16-A	40	50	27	38	38	400	-5	0	-	4.10	GI017	SV10



GI017
GI194
GI211

VB.. 1604..
VB.. 1103..
-

VC.. 1604..
VC.. 1103..
VC.. 1303..



S01
S08
SV10
SV21

US 2506-T07P
US 3510-T15P
US 3512-T15P
5513 020-24

0.9
3.0
3.0
1.5

M 2.5
M 3.5
M 3.5
M 3

6.3
10.6
12.6
8.5

-
-
SVN 160304
-

-
-
MS 3510
-

FLAG T07P
FLAG T15P
FLAG T15P
PT-8002

-
-
HXK 3.5
-



SVUB(C)(RL) INT

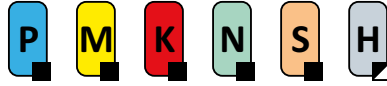

PRAMET

S



VB/VC.. Uç için Vida Sıkmalı 93° Açılı Delik Kateri

Vida sıkmalı Sağ/Sol 93° içten su vermeli delik kateri. Pozitif VB/VC.. 11 veya 16 uçlarla minimum Ø20mm çap, ve 50°'ye kadar kopya tornalama için uygundur. Ø16-40mm shaft ölçülerinde bulunur. Gövde uzun takım ömrü için işlem görmüştür.

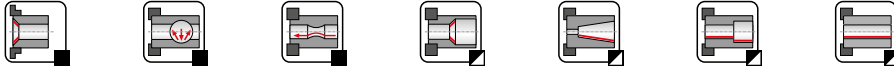
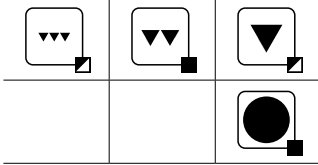
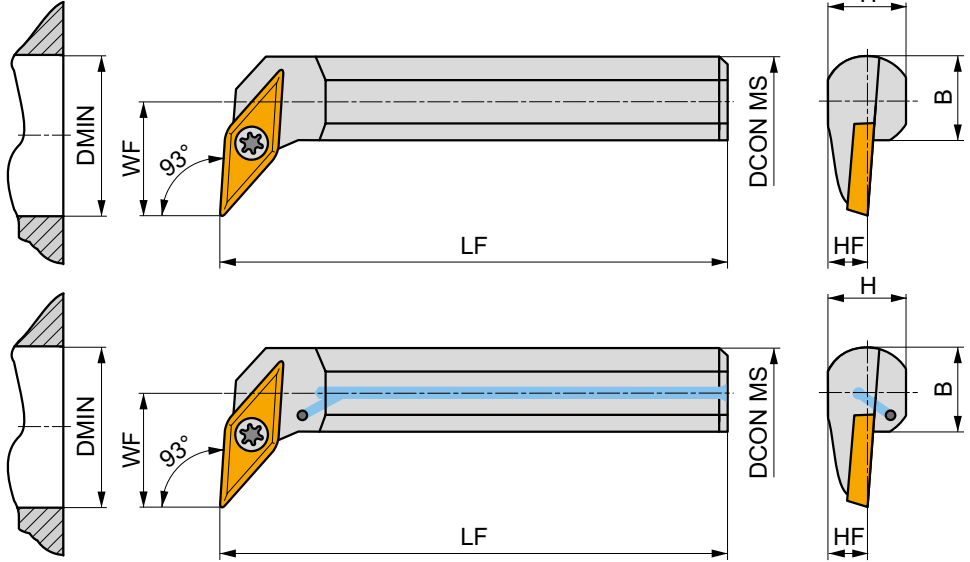
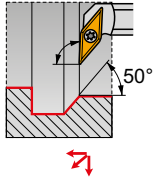

Product	DCON MS (mm)	DMIN (mm)	WF (mm)	H (mm)	B (mm)	LF (mm)	LAMS (°)	GAMO (°)	✓	kg	GI	SV
R A16R-SVUBR 11	16	20	11	14.5	15	200	-5	0	✓	0.34	GI194	S01
A20S-SVUBR 11	20	25	13	18	18.8	250	-4	0	✓	0.58	GI194	S01
A20S-SVUCR 13	20	25	13	19	18.5	250	-4	2	✓	0.40	GI211	SV21
A25T-SVUCR 13	25	32	17	24	23	300	-2	2	✓	0.96	GI211	SV22
A32T-SVUCR 13	32	40	22	30	30	300	-1	2	✓	1.70	GI211	SV22
S25T-SVUCR 16	25	32	17	23	23	300	-7	0	-	1.10	GI017	S08
S32U-SVUCR 16	32	40	22	30	30	350	-5	0	-	2.10	GI017	S08
S40V-SVUCR 16-A	40	50	27	38	38	400	-5	0	-	4.10	GI017	SV10
L A16R-SVUBL 11	16	20	11	14.5	15	200	-5	0	✓	0.34	GI194	S01
A20S-SVUBL 11	20	25	13	18	18.5	250	-4	0	✓	0.58	GI194	S01
A20S-SVUCL 13	20	25	13	19	18.5	250	-4	2	✓	0.32	GI211	SV21
A25T-SVUCL 13	25	32	17	24	23	300	-2	2	✓	0.96	GI211	SV22
A32T-SVUCL 13	32	40	22	30	30	300	-1	2	✓	1.70	GI211	SV22
S25T-SVUCL 16	25	32	17	23	23	300	-7	0	-	1.10	GI017	S08
S32U-SVUCL 16	32	40	22	30	30	350	-5	0	-	2.10	GI017	S08
S40V-SVUCL 16-A	40	50	27	38	38	400	-5	0	-	4.10	GI017	SV10



GI017
GI194
GI211

VB.. 1604..
VB.. 1103..
-

VC.. 1604..
VC.. 1103..
VC.. 1303..



S01
S08
SV10
SV21
SV22

US 2506-T07P
US 3510-T15P
US 3512-T15P
5513 020-24
DVF 0573

0.9
3.0
3.0
1.5
1.5

M 2.5
M 3.5
M 3.5
M 3
M 3

6.3
10.6
12.6
8.5
10.3

-
-
SVN 160304
-
DAP 0331

-
-
MS 3510
-
DVT 0332

FLAG T07P
FLAG T15P
FLAG T15P
PT-8002
PT-8002

-
-
HXK 3.5
-
174.1-870



SVXC(RL) INT

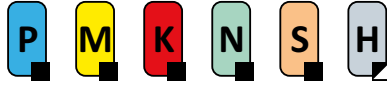

PRAMET

S



VC.. Uç için Vida Sıkmalı 113° Açılı Delik Kateri

Vida sıkmalı Sağ/Sol 113° içten su vermeli delik kateri. Pozitif VC.. 07 uçlarla minimum Ø12.5mm çap, ve 32°'ye kadar kopya tornalama için uygundur. Ø10-16mm şaft ölçülerinde bulunur. Gövde uzun takım ömrü için işlem görmüştür.

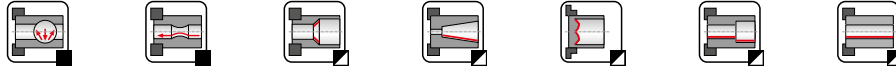
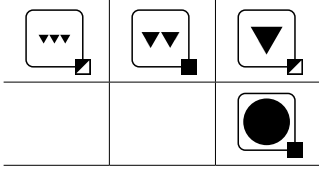
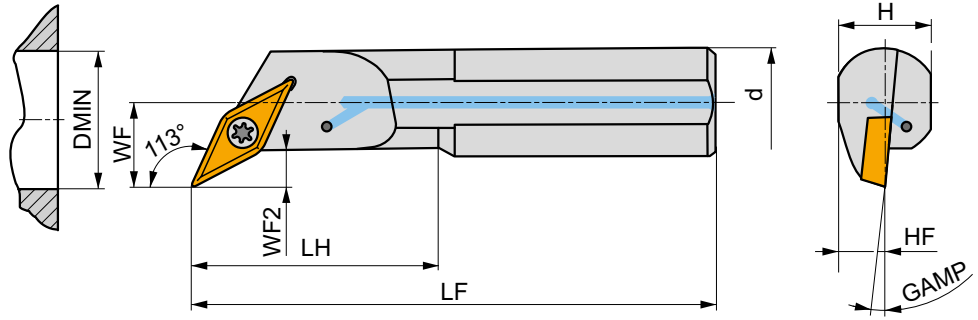
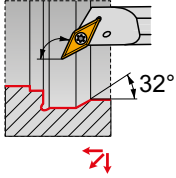

Product	DCON MS	DMIN	WF	H	LF	HF	LH	WF2	GAMP	✓	kg	GI234	SV23	
	(mm)	(mm)	(mm)	(mm)	(mm)	(mm)	(mm)	(mm)	(°)					
R	A10H-SVXCR 07	10	12.5	7	9	100	4.5	22	3	-10	✓	0.06	GI234	SV23
	A12K-SVXCR 07	12	15.5	9	11	125	5.5	28	3	-8	✓	0.11	GI234	SV23
	A16M-SVXCR 07	16	17.5	11	15	150	7.5	36	3	-6	✓	0.19	GI234	SV23
L	A10H-SVXCL 07	10	12.5	7	9	100	4.5	22	3	-10	✓	0.06	GI234	SV23
	A12K-SVXCL 07	12	15.5	9	11	125	5.5	28	3	-8	✓	0.11	GI234	SV23
	A16M-SVXCL 07	16	17.5	11	15	150	7.5	36	3	-6	✓	0.20	GI234	SV23



GI234



VC.. 0702..



SV23



DVF 3584



0.6



M 2



5.5



DMD 1650



SVXC(RL)-E INT



PRAMET

S



VC.. Uç için Vida Sıkmalı 113° Açılı Karbür Delik Kateri

Vida sıkmalı Sağ/Sol 113° içten su vermeli karbür delik kateri. Pozitif VC.. 07 uçlarla minimum Ø12.5mm çap, ve 32°'ye kadar kopya tormalama için uygundur. Ø10-32mm shaft ölçülerinde bulunur. Gövde uzun takım ömrü için işlem görmüştür. Delik boyu > 3xD

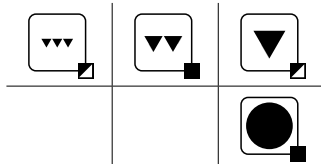
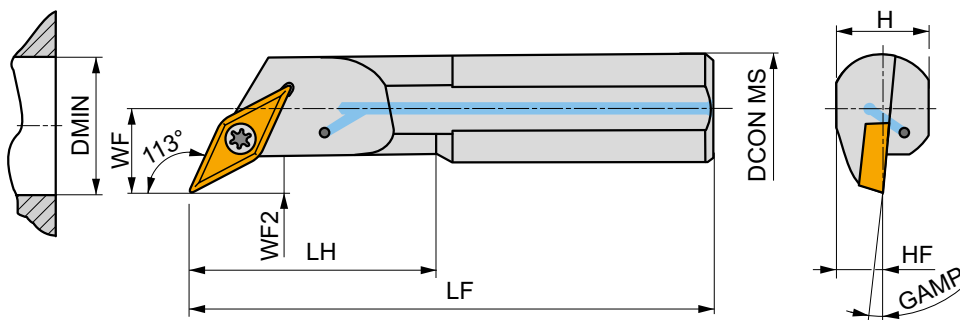
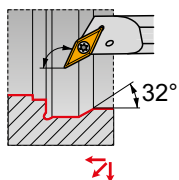

Product	DCON MS (mm)	DMIN (mm)	WF (mm)	H (mm)	HF (mm)	LF (mm)	LH (mm)	WF2 (mm)	GAMP (°)	✓	kg	GI234	SV23
R E10H-SVXCR 07	10	12.5	7	9	4.5	100	22	3	-10	✓	0.10	GI234	SV23
E12K-SVXCR 07	12	15.5	9	11	5.5	125	28	3	-8	✓	0.19	GI234	SV23
E16M-SVXCR 07	16	17.5	11	15	7.5	150	36	3	-6	✓	0.33	GI234	SV23
L E10H-SVXCL 07	10	12.5	7	9	4.5	100	22	3	-10	✓	0.10	GI234	SV23
E12K-SVXCL 07	12	15.5	9	11	5.5	125	28	3	-8	✓	0.19	GI234	SV23
E16M-SVXCL 07	16	17.5	11	15	7.5	150	36	3	-6	✓	0.33	GI234	SV23



GI234



VC.. 0702..



SV23



DVF 3584



0.6



M 2



5.5



DMD 1650

NEW
C.-SVQB(RL) INT

PRAMET
S

VB/VC.. Uç için Vida Sıkmalı 107.5° Açılı PSC Hızlı Değişirme Delik Takımı

Vida sıkımalı Sağ/Sol 107.5° içten su vermeli delik kateri. Pozitif VB/VC.. 16 uçlarla minimum Ø33mm çap ve birçok uygulama için uygundur. C4 ve C5 şaft ve çeşitli boy ölçülerinde bulunur. Gövde uzun takım ömrü için işlem görmüştür.

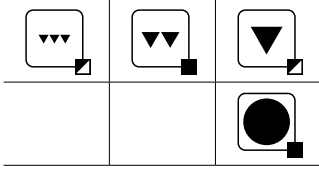
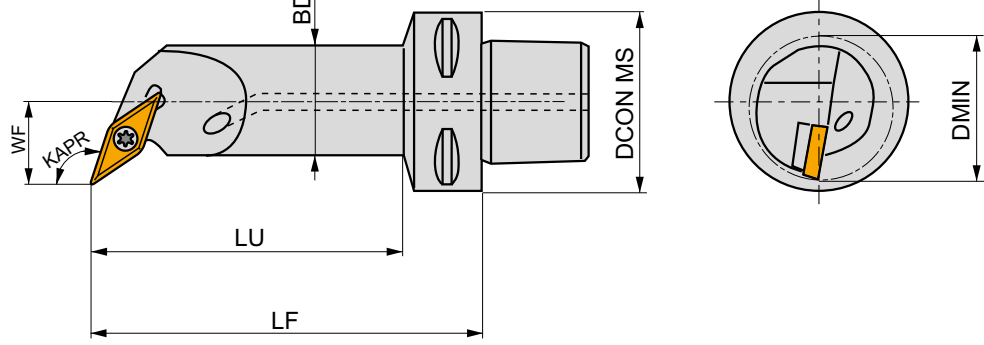
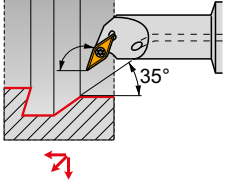

Product	DCON MS (mm)	DMIN (mm)	WF (mm)	LF (mm)	LU (mm)	BD (mm)	KAPR (°)	LAMS (°)	GAMO (°)				
R C4-SVQBR-18090-16	40	33	18	90	68	25	107.5	-7.2	0	✓	0.48	GI017	SV16
C5-SVQBR-18090-16	50	33	18	90	67	25	107.5	-7.2	0	✓	0.67	GI017	SV16
L C4-SVQBL-18090-16	40	33	18	90	68	25	107.5	-7.2	0	✓	0.48	GI017	SV16
C5-SVQBL-18090-16	50	33	18	90	67	25	107.5	-7.2	0	✓	0.68	GI017	SV16



GI017



VB.. 1604..



VC.. 1604..



SV16



US 2010-T15P



3.0



M 3.5



10.1



FLAG T15P/3,5



WC

02/ 06/ 08/ 16

KARBÜR UÇLAR

WCGT



212

WCGX



213

WCMT



213

DOĞRU BOYUTLA EŞLEŞTİRİN (örnek)

Kesici uç

WCGT 020102E-FF2

Takım Tutucu

A0508H-SWUCR 02

ISO TORNALAMA - DIŞ

SWLC(RL) EXT

95°

WC..

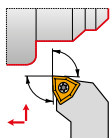
06
0816×16
25×25

215

212 – 214

ISO TORNALAMA - İÇ

SWLC(RL) INT

95°

WC..

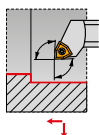
06
0825
40

216

212 – 214

SWUC(RL) INT

93°

WC..

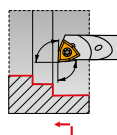

02

5,8
7,8

217

212 – 214

SWUC(RL)-E INT

93°

WC..

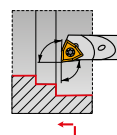

02

5,8
7,8

218

212 – 214



WCGT



	IC	D1	L	S
	(mm)	(mm)	(mm)	(mm)
0201	3.970	2.20	2.70	1.59
06T3	9.525	4.40	6.50	3.97
0804	12.700	5.50	8.70	4.76

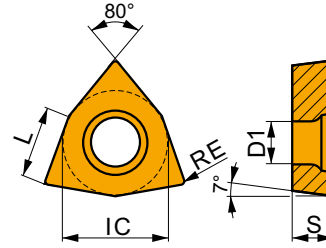

Kesme hızı (vc), ilerleme (f) ve kesme derinliği (ap) için uygunluk ve başlangıç değerleri. Daha ileri hesaplamalar için İşleme Hesaplayıcısı uygulamasına başvurun.

Product	RE	P			M			K			N			S			H		
		vc	f	ap	vc	f	ap	vc	f	ap	vc	f	ap	vc	f	ap	vc	f	ap
	(mm)	(m/min)	(mm/rev)	(mm)	(m/min)	(mm/rev)	(mm)	(m/min)	(mm/rev)	(mm)	(m/min)	(mm/rev)	(mm)	(m/min)	(mm/rev)	(mm)	(m/min)	(mm/rev)	(mm)

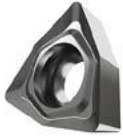

AL geometri, ince finişten kabaya, ve darbesizden hafif darbeli kesmeye kadar uygun, çok pozitif tasarım.

WCGT 06T302F-AL	HF7	0.2	-	-	-	-	-	-	-	450	0.12	1.0	-	-	-	-	-	-
WCGT 06T304F-AL	HF7	0.4	-	-	-	-	-	-	-	360	0.24	1.0	-	-	-	-	-	-
	T0315	0.4	-	-	-	-	-	-	-	525	0.24	1.0	-	-	-	-	-	-
WCGT 06T308F-AL	HF7	0.8	-	-	-	-	-	-	-	315	0.48	1.5	-	-	-	-	-	-
WCGT 080412F-AL	HF7	1.2	-	-	-	-	-	-	-	255	0.72	2.4	-	-	-	-	-	-
	T0315	1.2	-	-	-	-	-	-	-	375	0.72	2.4	-	-	-	-	-	-

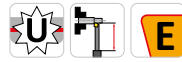
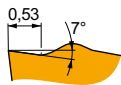

FF2 geometri, ince-finişten finişe işlemeye kadar için çok pozitif tasarım, darbesizden hafif darbeli işlemeye kadar uygun.

WCGT 020102E-FF2	HF7	0.2	-	-	-	-	-	210	0.05	0.8	-	-	-	-	-	-	-	-
	T8330	0.2	205	0.05	0.8	-	-	190	0.05	0.8	-	-	-	-	-	-	-	-
	T8430	0.2	280	0.05	0.8	-	-	230	0.05	0.8	-	-	-	-	-	-	-	-
	TT010	0.2	345	0.05	0.5	-	-	-	-	-	-	-	-	-	-	-	-	-
WCGT 020104E-FF2	HF7	0.4	-	-	-	-	-	155	0.12	0.8	-	-	-	-	-	-	-	-
	T8330	0.4	170	0.12	0.8	-	-	160	0.12	0.8	-	-	-	-	-	-	-	-
	T8430	0.4	205	0.12	0.8	-	-	170	0.12	0.8	-	-	-	-	-	-	-	-
	TT010	0.4	350	0.06	0.5	-	-	-	-	-	-	-	-	-	-	-	-	-



WCGX

	IC	D1	L	S
	(mm)	(mm)	(mm)	(mm)
0201	3.970	2.20	2.70	1.59

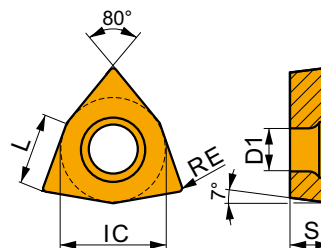

Kesme hızı (vc), ilerleme (f) ve kesme derinliği (ap) için uygunluk ve başlangıç değerleri. Daha ileri hesaplamalar için İşleme Hesaplayıcısı uygulamasına başvurun.

Product	RE	P			M			K			N			S			H		
		vc	f	ap	vc	f	ap	vc	f	ap	vc	f	ap	vc	f	ap	vc	f	ap
	(mm)	(m/min)	(mm/rev)	(mm)	(m/min)	(mm/rev)	(mm)	(m/min)	(mm/rev)	(mm)	(m/min)	(mm/rev)	(mm)	(m/min)	(mm/rev)	(mm)	(m/min)	(mm/rev)	(mm)

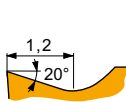

JZ sol kesme yönlü geometri, ince finiş işleme ve darbesiz kesim için.

WCGX 020102FL-JZ	TT010	0.2	■	330	0.06	0.5	■	195	0.05	0.5	■	-	-	-	■	-	-	-	■	-	-	-
------------------	-------	-----	---	-----	------	-----	---	-----	------	-----	---	---	---	---	---	---	---	---	---	---	---	---

WCMT

	IC	D1	L	S
	(mm)	(mm)	(mm)	(mm)
06T3	9.525	4.40	6.50	3.97
0804	12.700	5.50	8.70	4.76

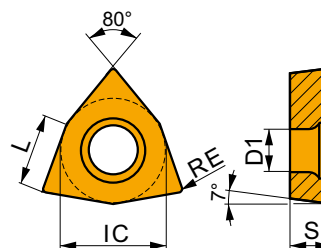

Kesme hızı (vc), ilerleme (f) ve kesme derinliği (ap) için uygunluk ve başlangıç değerleri. Daha ileri hesaplamalar için İşleme Hesaplayıcısı uygulamasına başvurun.

Product	RE	P			M			K			N			S			H		
		vc	f	ap	vc	f	ap	vc	f	ap	vc	f	ap	vc	f	ap	vc	f	ap
	(mm)	(m/min)	(mm/rev)	(mm)	(m/min)	(mm/rev)	(mm)	(m/min)	(mm/rev)	(mm)	(m/min)	(mm/rev)	(mm)	(m/min)	(mm/rev)	(mm)	(m/min)	(mm/rev)	(mm)

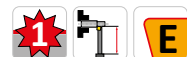
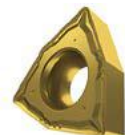

FM geometri, finişten yarı kaba işlemeye, ve darbesizden hafif darbeleri kesmeye kadar uygun.

WCMT 06T304E-FM	T7325	0.4	■	195	0.15	1.2	■	150	0.15	1.2	■	-	-	-	■	-	-	-	■	-	-	-
	T7335	0.4	■	190	0.15	1.2	■	145	0.15	1.2	■	-	-	-	■	-	-	-	■	-	-	-
	T8315	0.4	■	180	0.15	1.2	■	105	0.14	1.2	■	170	0.15	1.2	■	540	0.18	1.2	■	-	-	-
	T8330	0.4	■	170	0.15	1.2	■	100	0.14	1.2	■	160	0.15	1.2	■	510	0.18	1.2	■	-	-	-
	T8430	0.4	■	200	0.15	1.2	■	110	0.14	1.2	■	165	0.15	1.2	■	555	0.18	1.2	■	-	-	-
	T9315	0.4	■	275	0.15	1.2	■	-	-	-	■	260	0.15	1.2	■	-	-	-	■	-	-	-
WCMT 06T308E-FM	T9325	0.4	■	245	0.15	1.2	■	145	0.15	1.2	■	230	0.15	1.2	■	-	-	-	■	-	-	-
	T7325	0.8	■	215	0.20	1.2	■	165	0.18	1.2	■	-	-	-	■	-	-	-	■	-	-	-
	T7335	0.8	■	205	0.20	1.2	■	155	0.18	1.2	■	-	-	-	■	-	-	-	■	-	-	-
	T8315	0.8	■	195	0.20	1.2	■	115	0.18	1.2	■	185	0.20	1.2	■	585	0.24	1.2	■	-	-	-
	T8330	0.8	■	185	0.20	1.2	■	110	0.18	1.2	■	175	0.20	1.2	■	555	0.24	1.2	■	-	-	-
	T8430	0.8	■	210	0.20	1.2	■	115	0.18	1.2	■	175	0.20	1.2	■	585	0.24	1.2	■	-	-	-
	T9315	0.8	■	290	0.20	1.2	■	-	-	-	■	275	0.20	1.2	■	-	-	-	■	-	-	-
T9325	0.8	■	260	0.20	1.2	■	155	0.18	1.2	■	245	0.20	1.2	■	-	-	-	■	-	-	-	



Kesme hızı (vc), ilerleme (f) ve kesme derinliği (ap) için uygunluk ve başlangıç değerleri. Daha ileri hesaplamalar için İşleme Hesaplayıcısı uygulamasına başvurun.

Product	RE (mm)	P			M			K			N			S			H		
		vc (m/min)	f (mm/rev)	ap (mm)	vc (m/min)	f (mm/rev)	ap (mm)	vc (m/min)	f (mm/rev)	ap (mm)	vc (m/min)	f (mm/rev)	ap (mm)	vc (m/min)	f (mm/rev)	ap (mm)	vc (m/min)	f (mm/rev)	ap (mm)

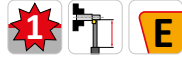
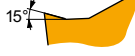
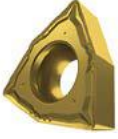

FM geometri, finiştan yarı kaba işlemeye, ve darbesizden hafif darbeleri kesmeye kadar uygun.

WCMT 080404E-FM	T7325	0.4	✓	190	0.15	1.7	■	145	0.15	1.7	—	—	—	—	—	—	—	—	—	
	T8315	0.4	✓	170	0.15	1.7	■	100	0.14	1.7	✓	160	0.15	1.7	✓	510	0.18	1.7	—	—
	T8330	0.4	■	165	0.15	1.7	■	95	0.14	1.7	✓	155	0.15	1.7	✓	495	0.18	1.7	—	—
	T8430	0.4	■	195	0.15	1.7	■	105	0.14	1.7	✓	160	0.15	1.7	✓	540	0.18	1.7	—	—
	T9315	0.4	■	265	0.15	1.7	—	—	—	—	✓	250	0.15	1.7	—	—	—	—	—	—
	T9325	0.4	■	240	0.15	1.7	■	140	0.15	1.7	✓	225	0.15	1.7	—	—	—	—	—	—
WCMT 080408E-FM	T7325	0.8	✓	205	0.20	1.7	■	155	0.18	1.7	—	—	—	—	—	—	—	—	—	
	T7335	0.8	✓	200	0.20	1.7	■	155	0.18	1.7	—	—	—	—	—	—	—	—	—	
	T8315	0.8	✓	190	0.20	1.7	■	110	0.18	1.7	✓	180	0.20	1.7	✓	570	0.24	1.7	—	—
	T8330	0.8	■	180	0.20	1.7	■	105	0.18	1.7	✓	170	0.20	1.7	✓	540	0.24	1.7	—	—
	T8430	0.8	■	205	0.20	1.7	■	110	0.18	1.7	✓	170	0.20	1.7	✓	570	0.24	1.7	—	—
	T9315	0.8	■	280	0.20	1.7	—	—	—	—	✓	265	0.20	1.7	—	—	—	—	—	—
WCMT 080412E-FM	T9325	0.8	■	250	0.20	1.7	■	150	0.18	1.7	✓	235	0.20	1.7	—	—	—	—	—	
	T8330	1.2	■	175	0.27	1.7	■	105	0.24	1.7	✓	165	0.27	1.7	✓	525	0.32	1.7	—	—
	T8430	1.2	■	190	0.27	1.7	■	105	0.24	1.7	✓	155	0.27	1.7	✓	525	0.32	1.7	—	—
T9325	1.2	■	235	0.27	1.7	■	140	0.24	1.7	✓	220	0.27	1.7	—	—	—	—	—	—	

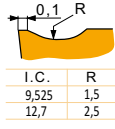

RF geometri, yarı kabadan kaba işlemeye kadar, ve darbesizden darbeleri kesime kadar uygun.

WCMT 06T308E-RF	T7335	0.8	✓	165	0.20	1.5	■	125	0.18	1.5	—	—	—	—	—	—	—	—	—
WCMT 080412E-RF	T7335	1.2	✓	160	0.22	2.2	■	120	0.22	2.2	—	—	—	—	—	—	—	—	—

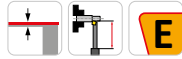
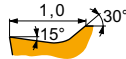

UR geometri, inceden finişe kadar işleme için, ve darbesiz ve hafif darbeleri kesim.

WCMT 06T308E-UR	T7325	0.8	✓	185	0.20	1.2	■	140	0.18	1.2	—	—	—	—	—	—	—	—	—
	T9315	0.8	■	250	0.20	1.2	—	—	—	✓	235	0.20	1.2	—	—	—	—	—	—
	T9325	0.8	■	225	0.20	1.2	■	135	0.18	1.2	✓	210	0.20	1.2	—	—	—	—	—



SWLC(RL) EXT



PRAMET

S

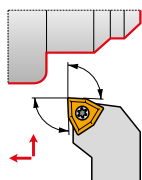

WC.. Uç için Vida Sıkmalı 95° Açılı Dış Kater

Vida sıkmalı Sağ/Sol dış kater. Pozitif WC.. 06 veya 08 uçlarla alın, çap, konik ve pah tornalama için uygundur. 16x16-25x25mm shaft ölçülerinde bulunur. Gövde uzun takım ömrü için işlem görmüştür.

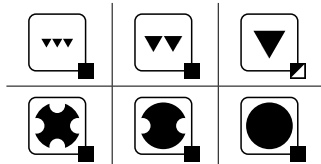
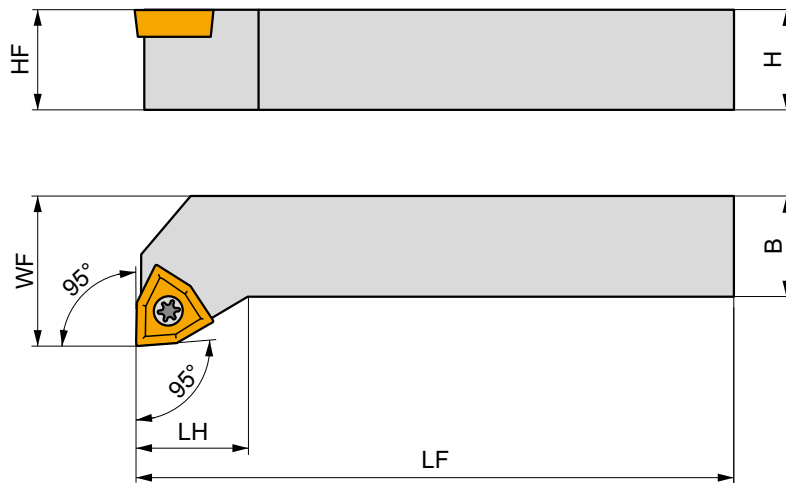

Product	H	B	HF	WF	LF	LH	LAMS	GAMO	kg	GI055	S04	
	(mm)	(mm)	(mm)	(mm)	(mm)	(mm)	(°)	(°)				
R	SWLCR 1616 H 06	16	16	16	20	100	15	0	0	0.24	GI055	S04
	SWLCR 2020 K 06	20	20	20	25	125	15	0	0	0.40	GI055	S04
	SWLCR 2525 M 08	25	25	25	32	150	20	0	0	0.77	GI049	S09
L	SWLCL 1616 H 06	16	16	16	20	100	15	0	0	0.23	GI055	S04
	SWLCL 2020 K 06	20	20	20	25	125	15	0	0	0.40	GI055	S04
	SWLCL 2525 M 08	25	25	25	32	150	20	0	0	0.75	GI049	S09



GI049

WC.. 0804..

GI055

WC.. 06T3..



S04

US 3510-T15P

3.0

M 3.5

10.6

FLAGT15P

S09

US 4512-T15P

5.0

M 4.5

12.2

FLAGT15P



SWLC(RL) INT

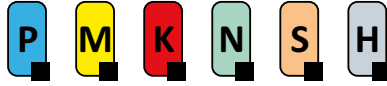

PRAMET

S

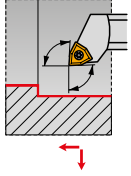

WC.. Uç için Vida Sıklı 95° Açılı Delik Kateri

Vida sıklı Sađ/Sol 95° için su vermeli delik kateri. Pozitif WC.. 06 veya 08 uçlarla minimum Ø25mm çap, konik ve pah tormalama için uygundur. Ø20-32mm şaft ölçülerinde bulunur. Gövde uzun takım ömrü için işlem görmüştür.

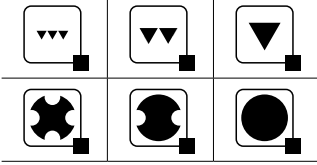
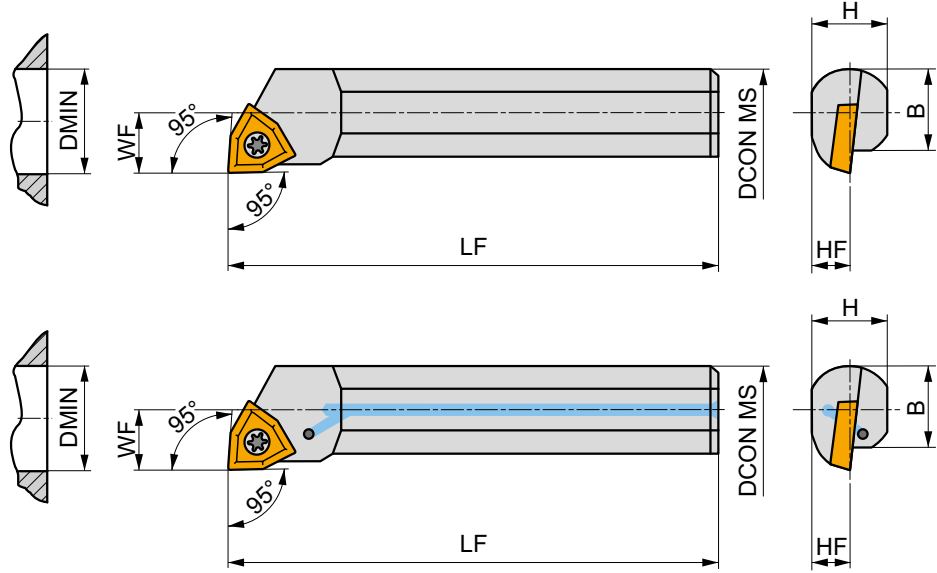

Product	DCON MS	DMIN	WF	H	B	LF	LAMS	GAMO		kg			
	(mm)	(mm)	(mm)	(mm)	(mm)	(mm)	(°)	(°)					
R	A20Q-SWLCR 06	20	25	13	18	18.5	180	-7	0	✓	0.37	GI055	S04
	S20S-SWLCR 06	20	25	13	18	18.5	250	-7	0	-	0.62	GI055	S04
	A25R-SWLCR 06	25	32	17	23	23	200	-7	0	✓	0.70	GI055	S04
	S25T-SWLCR 06	25	32	17	23	23	300	-7	0	-	1.15	GI055	S04
	A25R-SWLCR 08	25	32	17	23	23	200	-7	0	✓	0.70	GI049	S04
	A32S-SWLCR 08	32	40	22	30	30	250	-5	0	✓	1.32	GI049	S09
L	S32U-SWLCR 08	32	40	22	30	30	350	-5	0	-	2.05	GI049	S09
	A20Q-SWLCCL 06	20	25	13	18	18.5	180	-7	0	✓	0.00	GI055	S04
	S20S-SWLCCL 06	20	25	13	18	18.5	250	-7	0	-	0.60	GI055	S04
	A25R-SWLCCL 06	25	32	17	23	23	200	-7	0	✓	0.70	GI055	S04
	S25T-SWLCCL 06	25	32	17	23	23	300	-7	0	-	1.15	GI055	S04
	A25R-SWLCCL 08	25	32	17	23	23	200	-7	0	✓	0.70	GI049	S04
A32S-SWLCCL 08	32	40	22	30	30	250	-5	0	✓	1.32	GI049	S09	
S32U-SWLCCL 08	32	40	22	30	30	350	-5	0	-	4.10	GI049	S09	

GI049
GI055WC.. 0804..
WC.. 06T3..S04
S09US 3510-T15P
US 4512-T15P3.0
5.0M 3.5
M 4.510.6
12.2FLAGT15P
FLAGT15P



SWUC(RL) INT



PRAMET

S

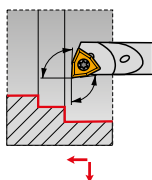

WC.. Uç için Vida Sıkmalı 93° Açılı Delik Kateri

Vida sıkmalı Sağ/Sol 93° içten su vermeli delik kateri. Pozitif WC.. 0201 uçlarla minimum Ø5.8mm çap, konik ve pah tornalama için uygundur. Ø8mm shaft ölçülerinde bulunur. Gövde uzun takım ömrü için işlem görmüştür.

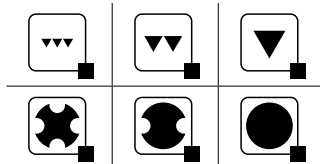
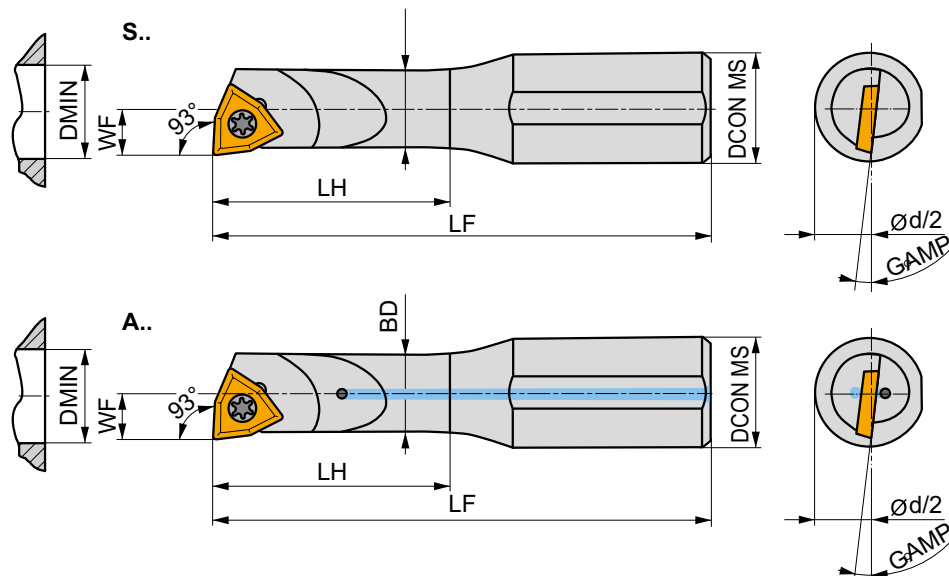

Product	DCON MS	DMIN	BD	WF	LF	LH	GAMP	GAMP	kg	GAMP	GAMP	
	(mm)	(mm)	(mm)	(mm)	(mm)	(mm)	(°)					
R	A0508H-SWUCR 02	8	5.8	5	2.9	100	18	-17	✓	0.09	GI221	SW21
	S0508H-SWUCR 02	8	5.8	5	2.9	100	18	-17	-	0.04	GI221	SW21
	A0608H-SWUCR 02	8	7.8	6	3.9	100	24	-12	✓	0.04	GI221	SW21
	S0608H-SWUCR 02	8	7.8	6	3.9	100	24	-12	-	0.04	GI221	SW21
L	A0508H-SWUCL 02	8	5.8	5	2.9	100	18	-17	✓	0.04	GI221	SW21
	S0508H-SWUCL 02	8	5.8	5	2.9	100	18	-17	-	0.04	GI221	SW21
	A0608H-SWUCL 02	8	7.8	6	3.9	100	24	-12	✓	0.04	GI221	SW21
	S0608H-SWUCL 02	8	7.8	6	3.9	100	24	-12	-	0.04	GI221	SW21



GI221



WC.. 0201..



SW21



T20.037



0.6



M 2



3.7



DMD 1650



SWUC(RL)-E INT

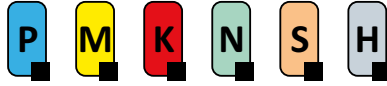

PRAMET

S



WC.. Uç için Vida Sıkmalı 93° Açılı Karbür Delik Kateri

Vida sıkmalı Sağ/Sol 93° içten su vermeli karbür delik kateri. Pozitif WC.. 0201 uçlarla minimum Ø5.8mm çap, konik ve pah tornalama için uygundur. Ø8mm shaft ölçülerinde bulunur. Gövde uzun takım ömrü için işlem görmüştür. Delik boyu > 3xD

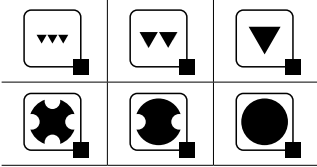
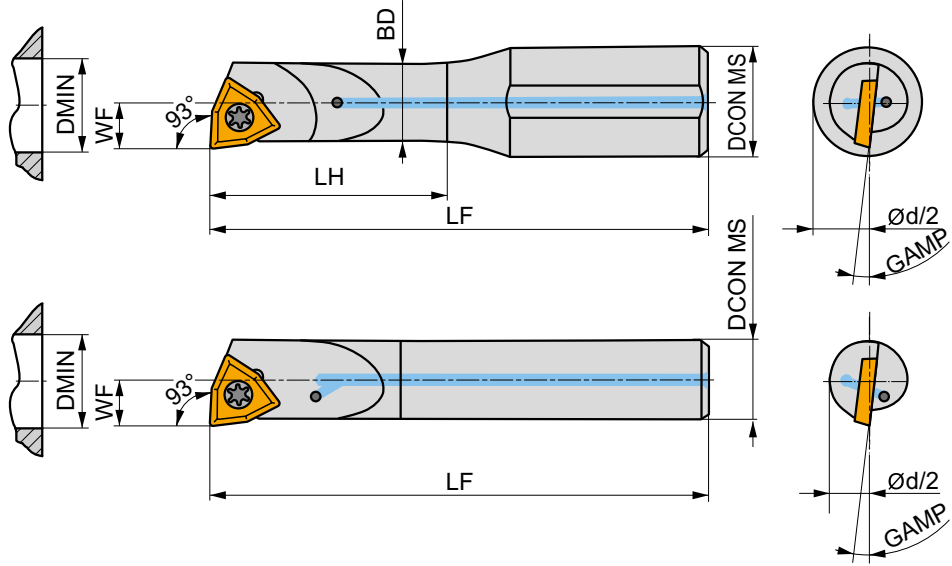
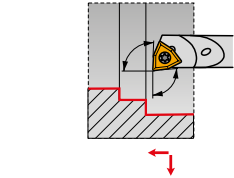

Product	DCON MS (mm)	DMIN (mm)	BD (mm)	WF (mm)	LF (mm)	LH (mm)	GAMP (°)				
R E0508H-SWUCR 02	8	5.8	5	2.9	100	24	-17	✓	0.06	GI221	SW21
E05F-SWUCR 02	5	5.8	-	2.9	85	-	-17	✓	0.03	GI221	SW21
E0608H-SWUCR 02	8	7.8	6	3.9	100	32	-12	✓	0.06	GI221	SW21
E06G-SWUCR 02	6	7.8	-	3.9	95	-	-12	✓	0.04	GI221	SW21
L E0508H-SWUCL 02	8	5.8	5	2.9	100	24	-17	✓	0.07	GI221	SW21
E05F-SWUCL 02	5	5.8	-	2.9	85	-	-17	✓	0.03	GI221	SW21
E0608H-SWUCL 02	8	7.8	6	3.9	100	32	-12	✓	0.06	GI221	SW21
E06G-SWUCL 02	6	7.8	-	3.9	95	-	-12	✓	0.04	GI221	SW21



GI221



WC.. 0201..



SW21



T20.037



0.6



M 2



3.7



DMD 1650



NEGATİF KESİCİ UÇLAR



CN

09/ 12/ 16/ 19/ 25

KARBÜR UÇLAR

CNGG	CNMA	CNMG	CNMM
222	222	223	234

CER VE CBN UÇLAR

CNGA CER	CNGN CER	CNGA CBN
238	238	239

DOĞRU BOYUTLA EŞLEŞTİRİN (örnek)

Kesici uç	Takım Tutucu
CNMM 120412E-OR	DCBNR 2525 M 12

ISO TORNALAMA - DIŞ

DCBN(RL) EXT	DCKN(RL) EXT	DCLN(RL) EXT	PCBN(RL) EXT
75°	75°	95°	75°
CN.. 12 16 19	CN.. 12 16	CN.. 09 12 16 19	CN.. 12 16 19 25
20×20 40×40	20×20 32×32	16×16 40×40	20×20 50×50
240	242	243	245
222 – 239	222 – 239	222 – 239	222 – 239
PCLN(RL) EXT	PCKN(RL) EXT	C.-DCLN(RL) EXT NEW	
95°	75°	95°	
CN.. 12 16 19 25	CN.. 12 16 19	CN.. 12 16 19	
20×20 50×50	20×20 40×40	C3 C8	
247	246	249	
222 – 239	222 – 239	222 – 239	



CN

09/ 12/ 16/ 19/ 25

ISO TORNALAMA - AĞIR KABA - DIŞ

KHP-CBNR + DKH(RL)

75°	CN..
	 25
	$\frac{40 \times 50}{60 \times 80}$
 251, 253	 222 - 239

KHP-CBNL + DKH(RL)

75°	CN..
	 25
	$\frac{40 \times 50}{60 \times 80}$
 251, 253	 222 - 239

KHP-CLNR/L + DKH(RL)

95°	CN..
	 19 25
	$\frac{40 \times 50}{60 \times 80}$
 252, 253	 222 - 239

ISO TORNALAMA - İÇ

DCLN(RL) INT

95°	CN..
	 09 12
	$\frac{32}{50}$
 254	 222 - 239

PCLN(RL) INT

95°	CN..
	 09 12 16 19
	$\frac{20}{80}$
 255	 222 - 239

C.-DCLN(RL) INT **NEW**

95°	CN..
	 09 12 16
	$\frac{25}{50}$
 257	 222 - 239



CNGG

	IC	D1	L	S
	(mm)	(mm)	(mm)	(mm)
1204	12.700	5.16	12.90	4.76

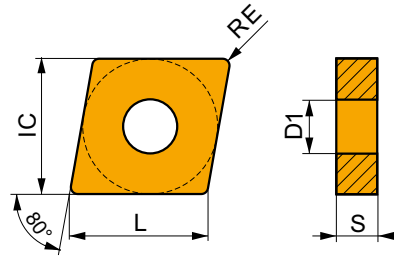

Kesme hızı (vc), ilerleme (f) ve kesme derinliği (ap) için uygunluk ve başlangıç değerleri. Daha ileri hesaplamalar için İşleme Hesaplayıcısı uygulamasına başvurun.

Product	RE	P			M			K			N			S			H		
		vc	f	ap	vc	f	ap	vc	f	ap	vc	f	ap	vc	f	ap	vc	f	ap
	(mm)	(m/min)	(mm/rev)	(mm)	(m/min)	(mm/rev)	(mm)	(m/min)	(mm/rev)	(mm)	(m/min)	(mm/rev)	(mm)	(m/min)	(mm/rev)	(mm)	(m/min)	(mm/rev)	(mm)

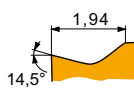

SF geometri, ince finiş ve ince cidar işlemek için pozitif tasarım, darbesiz kesim için uygun.

CNGG 120402E-SF	H07	0.2	–	–	–	105	0.09	1.0	165	0.10	1.0	525	0.12	1.0	50	0.08	0.8	–	–	–
	T6310	0.2	195	0.10	1.0	140	0.09	1.0	155	0.10	1.0	585	0.12	1.0	55	0.08	0.8	35	0.15	1.0
	T8315	0.2	205	0.10	1.0	120	0.09	1.0	190	0.10	1.0	615	0.12	1.0	50	0.08	0.8	40	0.15	1.0
	T8330	0.2	195	0.10	1.0	115	0.09	1.0	185	0.10	1.0	585	0.12	1.0	45	0.08	0.8	35	0.15	1.0
	T8430	0.2	240	0.10	1.0	130	0.09	1.0	195	0.10	1.0	660	0.12	1.0	50	0.08	0.8	40	0.15	1.0

CNMA

	IC	D1	L	S
	(mm)	(mm)	(mm)	(mm)
1204	12.700	5.16	12.90	4.76
1606	15.875	6.35	16.10	6.35
1906	19.050	7.94	19.30	6.35

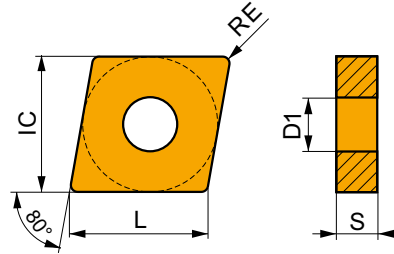

Kesme hızı (vc), ilerleme (f) ve kesme derinliği (ap) için uygunluk ve başlangıç değerleri. Daha ileri hesaplamalar için İşleme Hesaplayıcısı uygulamasına başvurun.

Product	RE	P			M			K			N			S			H		
		vc	f	ap	vc	f	ap	vc	f	ap	vc	f	ap	vc	f	ap	vc	f	ap
	(mm)	(m/min)	(mm/rev)	(mm)	(m/min)	(mm/rev)	(mm)	(m/min)	(mm/rev)	(mm)	(m/min)	(mm/rev)	(mm)	(m/min)	(mm/rev)	(mm)	(m/min)	(mm/rev)	(mm)

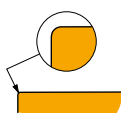

İnce finişten yarı kaba işleme kadar ve darbesizden hafif darbeli kesmeye kadar uygun.

CNMA 120404	T5305	0.4	–	–	–	–	–	–	235	0.10	4.0	–	–	–	–	–	–	50	0.15	1.0
	T5315	0.4	–	–	–	–	–	–	200	0.10	4.0	–	–	–	–	–	–	40	0.15	1.0
CNMA 120408	T5305	0.8	–	–	–	–	–	–	220	0.20	4.0	–	–	–	–	–	–	45	0.15	1.0
	T5315	0.8	–	–	–	–	–	–	190	0.20	4.0	–	–	–	–	–	–	40	0.15	1.0
CNMA 120412	T6310	0.8	–	–	–	–	–	–	100	0.20	4.0	–	–	–	–	–	–	25	0.15	1.0
	T5305	1.2	–	–	–	–	–	–	195	0.30	4.0	–	–	–	–	–	–	40	0.15	1.0
CNMA 120416	T5315	1.2	–	–	–	–	–	–	180	0.30	4.0	–	–	–	–	–	–	35	0.15	1.0
	T6310	1.2	–	–	–	–	–	–	95	0.30	4.0	–	–	–	–	–	–	20	0.15	1.0
CNMA 120416	T5305	1.6	–	–	–	–	–	–	190	0.40	4.0	–	–	–	–	–	–	40	0.15	1.0
	T5315	1.6	–	–	–	–	–	–	170	0.40	4.0	–	–	–	–	–	–	35	0.15	1.0



Kesme hızı (vc), ilerleme (f) ve kesme derinliği (ap) için uygunluk ve başlangıç değerleri. Daha ileri hesaplamalar için İşleme Hesaplayıcısı uygulamasına başvurun.

Product	RE (mm)	P			M			K			N			S			H		
		vc (m/min)	f (mm/rev)	ap (mm)	vc (m/min)	f (mm/rev)	ap (mm)	vc (m/min)	f (mm/rev)	ap (mm)	vc (m/min)	f (mm/rev)	ap (mm)	vc (m/min)	f (mm/rev)	ap (mm)	vc (m/min)	f (mm/rev)	ap (mm)

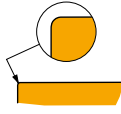

İnce finişten yarı kaba işleme kadar ve darbesizden hafif darbeli kesmeye kadar uygun.

CNMA 160612	T5305	1.2	-	-	-	-	-	-	190	0.30	5.0	-	-	-	-	-	40	0.15	1.0
	T5315	1.2	-	-	-	-	-	-	175	0.30	5.0	-	-	-	-	-	35	0.15	1.0
	T6310	1.2	-	-	-	-	-	-	90	0.30	5.0	-	-	-	-	-	20	0.15	1.0
CNMA 160616	T5305	1.6	-	-	-	-	-	-	185	0.40	5.0	-	-	-	-	-	35	0.15	1.0
	T5315	1.6	-	-	-	-	-	-	165	0.40	5.0	-	-	-	-	-	35	0.15	1.0
CNMA 190612	T5305	1.2	-	-	-	-	-	-	190	0.30	6.0	-	-	-	-	-	40	0.15	1.0
	T5315	1.2	-	-	-	-	-	-	170	0.30	6.0	-	-	-	-	-	35	0.15	1.0
	T6310	1.2	-	-	-	-	-	-	85	0.30	6.0	-	-	-	-	-	20	0.15	1.0
CNMA 190616	T5305	1.6	-	-	-	-	-	-	180	0.40	6.0	-	-	-	-	-	35	0.15	1.0
	T5315	1.6	-	-	-	-	-	-	160	0.40	6.0	-	-	-	-	-	30	0.15	1.0

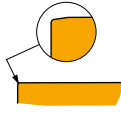

İnce finişten yarı kaba işleme kadar ve darbesizden hafif darbeli kesmeye kadar uygun.

CNMA 120408S	T5305	0.8	-	-	-	-	-	-	220	0.20	4.0	-	-	-	-	-	45	0.15	1.0
CNMA 120412S	T5305	1.2	-	-	-	-	-	-	190	0.40	4.0	-	-	-	-	-	40	0.15	1.0
CNMA 160612S	T5305	1.2	-	-	-	-	-	-	190	0.30	5.0	-	-	-	-	-	40	0.15	1.0
CNMA 190616S	T5305	1.6	-	-	-	-	-	-	180	0.40	6.0	-	-	-	-	-	35	0.15	1.0

CNMG

PRAMET

	IC (mm)	D1 (mm)	L (mm)	S (mm)
0903	9.525	3.81	9.70	3.18
1204	12.700	5.16	12.90	4.76
1606	15.880	6.35	16.10	6.35
1906	19.050	7.94	19.30	6.35
2509	25.400	9.12	25.80	9.53

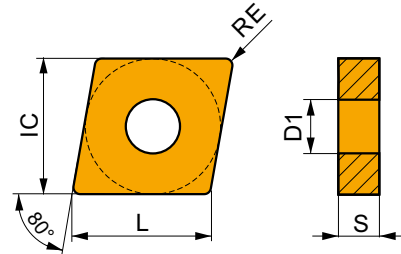

Kesme hızı (vc), ilerleme (f) ve kesme derinliği (ap) için uygunluk ve başlangıç değerleri. Daha ileri hesaplamalar için İşleme Hesaplayıcısı uygulamasına başvurun.

Product	RE (mm)	P			M			K			N			S			H		
		vc (m/min)	f (mm/rev)	ap (mm)	vc (m/min)	f (mm/rev)	ap (mm)	vc (m/min)	f (mm/rev)	ap (mm)	vc (m/min)	f (mm/rev)	ap (mm)	vc (m/min)	f (mm/rev)	ap (mm)	vc (m/min)	f (mm/rev)	ap (mm)

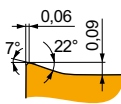

FF geometri, ince-finiş işleme için çok pozitif tasarım, darbesizden hafif darbeli işleme kadar uygun.

CNMG 120404E-FF	T7325	0.4	235	0.12	1.0	180	0.11	1.0	-	-	-	-	-	-	-	-	-	-
	T8315	0.4	220	0.12	1.0	130	0.11	1.0	205	0.12	1.0	-	-	-	-	-	-	-
CNMG 120408E-FF	T7325	0.8	265	0.15	1.0	205	0.14	1.0	-	-	-	-	-	-	-	-	-	-
	T8315	0.8	245	0.15	1.0	145	0.14	1.0	230	0.15	1.0	-	-	-	-	-	-	-



Kesme hızı (vc), ilerleme (f) ve kesme derinliği (ap) için uygunluk ve başlangıç değerleri. Daha ileri hesaplamalar için İşleme Hesaplayıcısı uygulamasına başvurun.

Product	RE (mm)	P			M			K			N			S			H		
		vc (m/min)	f (mm/rev)	ap (mm)	vc (m/min)	f (mm/rev)	ap (mm)	vc (m/min)	f (mm/rev)	ap (mm)	vc (m/min)	f (mm/rev)	ap (mm)	vc (m/min)	f (mm/rev)	ap (mm)	vc (m/min)	f (mm/rev)	ap (mm)

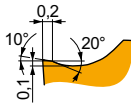

FM pozitif geometri, finişten yarı kaba işleme, ve darbesizden hafif darbeli kesmeye kadar uygun.

CNMG 090304E-FM	T7325	0.4	195	0.20	1.4	150	0.18	1.4	-	-	-	60	0.16	1.1	-	-	-	
	T8330	0.4	175	0.20	1.4	105	0.18	1.4	165	0.20	1.4	40	0.14	1.1	-	-	-	
	T8430	0.4	195	0.20	1.4	105	0.18	1.4	160	0.20	1.4	40	0.14	1.1	-	-	-	
	T9315	0.4	265	0.20	1.4	-	-	-	250	0.20	1.4	-	-	-	-	-	-	-
	T9325	0.4	240	0.20	1.4	140	0.18	1.4	225	0.20	1.4	50	0.16	1.1	-	-	-	
CNMG 090308E-FM	T7325	0.8	235	0.20	1.4	180	0.18	1.4	-	-	-	75	0.16	1.1	-	-	-	
	T8330	0.8	205	0.20	1.4	120	0.18	1.4	190	0.20	1.4	50	0.14	1.1	-	-	-	
	T8430	0.8	235	0.20	1.4	125	0.18	1.4	190	0.20	1.4	50	0.14	1.1	-	-	-	
	T9315	0.8	315	0.20	1.4	-	-	-	295	0.20	1.4	-	-	-	-	-	-	
	T9325	0.8	285	0.20	1.4	170	0.18	1.4	270	0.20	1.4	60	0.16	1.1	-	-	-	
CNMG 120404E-FM	T7325	0.4	185	0.20	2.1	140	0.18	2.1	-	-	-	60	0.16	1.7	-	-	-	
	T7335	0.4	180	0.20	2.1	140	0.18	2.1	-	-	-	55	0.16	1.7	-	-	-	
	T8315	0.4	175	0.20	2.1	105	0.18	2.1	165	0.20	2.1	40	0.14	1.7	-	-	-	
	T8330	0.4	165	0.20	2.1	95	0.18	2.1	155	0.20	2.1	40	0.14	1.7	-	-	-	
	T8430	0.4	190	0.20	2.1	105	0.18	2.1	155	0.20	2.1	40	0.14	1.7	-	-	-	
	T9310	0.4	285	0.20	2.1	-	-	-	270	0.20	2.1	-	-	-	-	-	-	
	T9315	0.4	255	0.20	2.1	-	-	-	240	0.20	2.1	-	-	-	-	-	-	
	T9325	0.4	230	0.20	2.1	135	0.18	2.1	215	0.20	2.1	50	0.16	1.7	-	-	-	
CNMG 120408E-FM	TT310	0.4	260	0.20	2.1	155	0.18	2.1	-	-	-	-	-	-	-	-	-	
	T7325	0.8	220	0.20	2.1	170	0.18	2.1	-	-	-	70	0.16	1.7	-	-	-	
	T7335	0.8	215	0.20	2.1	165	0.18	2.1	-	-	-	65	0.16	1.7	-	-	-	
	T8315	0.8	205	0.20	2.1	120	0.18	2.1	190	0.20	2.1	50	0.16	1.7	-	-	-	
	T8330	0.8	195	0.20	2.1	115	0.18	2.1	185	0.20	2.1	45	0.16	1.7	-	-	-	
	T8430	0.8	225	0.20	2.1	120	0.18	2.1	185	0.20	2.1	45	0.16	1.7	-	-	-	
	T9310	0.8	335	0.20	2.1	-	-	-	315	0.20	2.1	-	-	-	-	-	-	
	T9315	0.8	305	0.20	2.1	-	-	-	285	0.20	2.1	-	-	-	-	-	-	
CNMG 120412E-FM	T9325	0.8	275	0.20	2.1	165	0.18	2.1	260	0.20	2.1	60	0.16	1.7	-	-	-	
	TT310	0.8	310	0.20	2.1	185	0.18	2.1	-	-	-	-	-	-	-	-	-	
	T7325	1.2	210	0.27	2.1	160	0.24	2.1	-	-	-	65	0.19	1.7	-	-	-	
	T9315	1.2	285	0.27	2.1	-	-	-	270	0.27	2.1	-	-	-	-	-	-	
T9325	1.2	255	0.27	2.1	150	0.24	2.1	240	0.27	2.1	55	0.19	1.7	-	-	-		

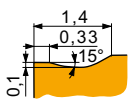

KR geometri, yarı kabadan kaba işleme kadar, darbesizden darbeli kesime kadar uygun.

CNMG 120408E-KR	T5305	0.8	255	0.35	4.0	-	-	-	240	0.35	4.0	50	0.15	1.0	-	-	-
	T5315	0.8	225	0.35	4.0	-	-	-	210	0.35	4.0	45	0.15	1.0	-	-	-
CNMG 120412E-KR	T5305	1.2	255	0.40	4.0	-	-	-	240	0.40	4.0	50	0.15	1.0	-	-	-
	T5315	1.2	230	0.40	4.0	-	-	-	215	0.40	4.0	45	0.15	1.0	-	-	-

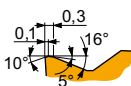

M geometri, finişten yarı kaba işleme kadar ve darbesizden darbeli kesime kadar uygun.

CNMG 090308E-M	T9315	0.8	230	0.32	1.8	-	-	-	215	0.32	1.8	45	0.15	1.0	-	-	-
	T9325	0.8	205	0.32	1.8	-	-	-	190	0.32	1.8	-	-	-	-	-	-
	T9335	0.8	180	0.32	1.8	-	-	-	-	-	-	-	-	-	-	-	-
CNMG 120404E-M	T5315	0.4	245	0.20	2.1	-	-	-	230	0.20	2.1	45	0.15	1.0	-	-	-
	T9310	0.4	260	0.20	2.1	-	-	-	245	0.20	2.1	50	0.15	1.0	-	-	-
	T9315	0.4	235	0.20	2.1	-	-	-	220	0.20	2.1	45	0.15	1.0	-	-	-
	T9325	0.4	210	0.20	2.1	-	-	-	195	0.20	2.1	-	-	-	-	-	-
	T9335	0.4	180	0.20	2.1	-	-	-	-	-	-	-	-	-	-	-	-



Kesme hızı (vc), ilerleme (f) ve kesme derinliği (ap) için uygunluk ve başlangıç değerleri. Daha ileri hesaplamalar için İşleme Hesaplayıcısı uygulamasına başvurun.

Product	RE (mm)	P			M			K			N			S			H		
		vc (m/min)	f (mm/rev)	ap (mm)	vc (m/min)	f (mm/rev)	ap (mm)	vc (m/min)	f (mm/rev)	ap (mm)	vc (m/min)	f (mm/rev)	ap (mm)	vc (m/min)	f (mm/rev)	ap (mm)	vc (m/min)	f (mm/rev)	ap (mm)

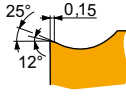

NF geometri, ince finiştten orta kabaya kadar işlemek için çok pozitif tasarım, darbesiz kesim için uygun.

CNMG 120404E-NF	HF7	0.4	–	–	–	95	0.15	1.7	155	0.17	1.7	495	0.20	1.7	–	–	–	–	–	–
	T6310	0.4	180	0.17	1.7	125	0.15	1.7	145	0.17	1.7	540	0.20	1.7	50	0.14	1.4	–	–	–
	T7325	0.4	200	0.18	1.7	155	0.16	1.7	–	–	–	–	–	–	65	0.16	1.4	–	–	–
	T7335	0.4	195	0.18	1.7	150	0.16	1.7	–	–	–	–	–	–	60	0.16	1.4	–	–	–
	T8315	0.4	185	0.17	1.7	110	0.15	1.7	175	0.17	1.7	555	0.20	1.7	45	0.14	1.4	–	–	–
	T8330	0.4	180	0.17	1.7	105	0.15	1.7	170	0.17	1.7	540	0.20	1.7	45	0.14	1.4	–	–	–
	T8430	0.4	200	0.17	1.7	110	0.15	1.7	165	0.17	1.7	555	0.20	1.7	40	0.14	1.4	–	–	–
	T9315	0.4	285	0.17	1.7	–	–	–	270	0.17	1.7	–	–	–	–	–	–	–	–	–
	T9325	0.4	250	0.18	1.7	150	0.16	1.7	235	0.18	1.7	–	–	–	55	0.16	1.4	–	–	–
CNMG 120408E-NF	HF7	0.8	–	–	–	110	0.17	1.7	180	0.19	1.7	570	0.23	1.7	–	–	–	–	–	–
	T6310	0.8	200	0.19	1.7	140	0.17	1.7	160	0.19	1.7	600	0.23	1.7	60	0.15	1.4	–	–	–
	T7325	0.8	235	0.19	1.7	180	0.17	1.7	–	–	–	–	–	75	0.15	1.4	–	–	–	
	T7335	0.8	225	0.19	1.7	175	0.17	1.7	–	–	–	–	–	70	0.15	1.4	–	–	–	
	T8315	0.8	215	0.19	1.7	125	0.17	1.7	200	0.19	1.7	645	0.23	1.7	50	0.15	1.4	–	–	–
	T8330	0.8	200	0.19	1.7	120	0.17	1.7	190	0.19	1.7	600	0.23	1.7	50	0.15	1.4	–	–	–
	T8430	0.8	235	0.19	1.7	125	0.17	1.7	190	0.19	1.7	645	0.23	1.7	50	0.15	1.4	–	–	–
	T9315	0.8	320	0.19	1.7	–	–	–	300	0.19	1.7	–	–	–	–	–	–	–	–	–
	T9325	0.8	285	0.19	1.7	170	0.17	1.7	270	0.19	1.7	–	–	–	60	0.15	1.4	–	–	–
CNMG 120412E-NF	T6310	1.2	185	0.30	2.1	130	0.27	2.1	145	0.30	2.1	555	0.36	2.1	55	0.21	1.7	–	–	–
	T7325	1.2	205	0.30	2.1	155	0.27	2.1	–	–	–	–	–	65	0.21	1.7	–	–	–	
	T7335	1.2	200	0.30	2.1	155	0.27	2.1	–	–	–	–	–	65	0.21	1.7	–	–	–	
	T8330	1.2	185	0.30	2.1	110	0.27	2.1	175	0.30	2.1	555	0.36	2.1	45	0.21	1.7	–	–	–
	T8430	1.2	200	0.30	2.1	110	0.27	2.1	165	0.30	2.1	555	0.36	2.1	40	0.21	1.7	–	–	–
	T9315	1.2	275	0.30	2.1	–	–	–	260	0.30	2.1	–	–	–	–	–	–	–	–	–
	T9325	1.2	245	0.30	2.1	145	0.27	2.1	230	0.30	2.1	–	–	–	55	0.21	1.7	–	–	–

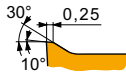

NM geometri, ince finiş, orta ve kaba işlemek için çok pozitif tasarım, darbesiz kesim için uygun.

CNMG 120404E-NM	T7325	0.4	195	0.20	2.1	150	0.18	2.1	–	–	–	–	–	60	0.16	1.7	–	–	–	
	T7335	0.4	190	0.20	2.1	145	0.18	2.1	–	–	–	–	–	60	0.16	1.7	–	–	–	
	T8315	0.4	180	0.20	2.1	105	0.18	2.1	–	–	–	540	0.24	2.1	45	0.16	1.7	–	–	–
	T8330	0.4	170	0.20	2.1	100	0.18	2.1	–	–	–	510	0.24	2.1	40	0.16	1.7	–	–	–
	T8430	0.4	195	0.20	2.1	105	0.18	2.1	–	–	–	540	0.24	2.1	40	0.16	1.7	–	–	–
	T9315	0.4	270	0.20	2.1	–	–	–	–	–	–	–	–	–	–	–	–	–	–	–
	T9325	0.4	240	0.20	2.1	140	0.18	2.1	–	–	–	–	–	–	50	0.16	1.7	–	–	–
CNMG 120408E-NM	T7325	0.8	215	0.25	2.1	165	0.23	2.1	–	–	–	–	–	65	0.20	1.7	–	–	–	
	T7335	0.8	210	0.25	2.1	160	0.23	2.1	–	–	–	–	–	65	0.20	1.7	–	–	–	
	T8315	0.8	205	0.25	2.1	120	0.23	2.1	–	–	–	615	0.30	2.1	50	0.20	1.7	–	–	–
	T8330	0.8	195	0.25	2.1	115	0.23	2.1	–	–	–	585	0.30	2.1	45	0.20	1.7	–	–	–
	T8430	0.8	210	0.25	2.1	115	0.23	2.1	–	–	–	585	0.30	2.1	45	0.20	1.7	–	–	–
	T9315	0.8	290	0.25	2.1	–	–	–	–	–	–	–	–	–	–	–	–	–	–	–
	T9325	0.8	260	0.25	2.1	155	0.23	2.1	–	–	–	–	–	–	55	0.20	1.7	–	–	–
CNMG 120412E-NM	T7325	1.2	215	0.30	2.1	165	0.27	2.1	–	–	–	–	–	65	0.24	1.7	–	–	–	
	T7335	1.2	210	0.30	2.1	160	0.27	2.1	–	–	–	–	–	65	0.24	1.7	–	–	–	
	T8315	1.2	205	0.30	2.1	120	0.27	2.1	–	–	–	615	0.36	2.1	50	0.24	1.7	–	–	–
	T8330	1.2	195	0.30	2.1	115	0.27	2.1	–	–	–	585	0.36	2.1	45	0.24	1.7	–	–	–
	T8430	1.2	210	0.30	2.1	115	0.27	2.1	–	–	–	585	0.36	2.1	45	0.24	1.7	–	–	–
	T9315	1.2	285	0.30	2.1	–	–	–	–	–	–	–	–	–	–	–	–	–	–	–
	T9325	1.2	255	0.30	2.1	150	0.27	2.1	–	–	–	–	–	–	55	0.24	1.7	–	–	–
CNMG 160608E-NM	T7325	0.8	195	0.30	3.6	150	0.27	3.6	–	–	–	–	–	60	0.27	2.9	–	–	–	
	T7335	0.8	190	0.30	3.6	145	0.27	3.6	–	–	–	–	–	60	0.27	2.9	–	–	–	
	T8315	0.8	185	0.30	3.6	110	0.27	3.6	–	–	–	555	0.36	3.6	45	0.27	2.9	–	–	–
	T8330	0.8	170	0.30	3.6	100	0.27	3.6	–	–	–	510	0.36	3.6	40	0.27	2.9	–	–	–
	T8430	0.8	185	0.30	3.6	100	0.27	3.6	–	–	–	510	0.36	3.6	40	0.27	2.9	–	–	–
	T9325	0.8	225	0.30	3.6	135	0.27	3.6	–	–	–	–	–	–	50	0.27	2.9	–	–	–



Kesme hızı (vc), ilerleme (f) ve kesme derinliği (ap) için uygunluk ve başlangıç değerleri. Daha ileri hesaplamalar için İşleme Hesaplayıcısı uygulamasına başvurun.

Product	RE (mm)	P			M			K			N			S			H		
		vc (m/min)	f (mm/rev)	ap (mm)	vc (m/min)	f (mm/rev)	ap (mm)	vc (m/min)	f (mm/rev)	ap (mm)	vc (m/min)	f (mm/rev)	ap (mm)	vc (m/min)	f (mm/rev)	ap (mm)	vc (m/min)	f (mm/rev)	ap (mm)

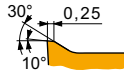

NM geometri, ince finiş, orta ve kaba işlemek için çok pozitif tasarım, darbesiz kesim için uygun.

CNMG 160612E-NM	T7325	1.2	205	0.30	3.6	155	0.27	3.6	-	-	-	-	-	-	65	0.27	2.9	-	-	-
	T7335	1.2	200	0.30	3.6	155	0.27	3.6	-	-	-	-	-	-	65	0.27	2.9	-	-	-
	T8315	1.2	195	0.30	3.6	115	0.27	3.6	-	-	-	585	0.36	3.6	45	0.27	2.9	-	-	-
	T9325	1.2	240	0.30	3.6	140	0.27	3.6	-	-	-	-	-	-	50	0.27	2.9	-	-	-
CNMG 190612E-NM	T7325	1.2	195	0.35	4.2	150	0.32	4.2	-	-	-	-	-	-	60	0.32	3.4	-	-	-
	T7335	1.2	180	0.35	4.2	140	0.32	4.2	-	-	-	-	-	-	55	0.32	3.4	-	-	-
	T8315	1.2	180	0.35	4.2	105	0.32	4.2	-	-	-	540	0.42	4.2	45	0.32	3.4	-	-	-
	T8330	1.2	170	0.35	4.2	100	0.32	4.2	-	-	-	510	0.42	4.2	40	0.32	3.4	-	-	-
	T8430	1.2	180	0.35	4.2	95	0.32	4.2	-	-	-	495	0.42	4.2	35	0.32	3.4	-	-	-
	T9325	1.2	220	0.35	4.2	130	0.32	4.2	-	-	-	-	-	-	45	0.32	3.4	-	-	-

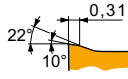

NMR geometri, ortadan kabaya kadar işlemek için pozitif tasarım, darbesiz kesim için uygun.

CNMG 090308E-NMR	T7325	0.8	175	0.35	1.6	135	0.32	1.6	-	-	-	-	-	-	55	0.25	1.3	-	-	-
	T7335	0.8	170	0.35	1.6	130	0.32	1.6	-	-	-	-	-	-	55	0.25	1.3	-	-	-
	T9325	0.8	200	0.35	1.6	120	0.32	1.6	-	-	-	-	-	-	45	0.25	1.3	-	-	-
CNMG 120404E-NMR	T6310	0.4	140	0.25	2.7	100	0.23	2.7	-	-	-	-	-	-	40	0.20	2.2	-	-	-
	T7325	0.4	155	0.25	2.7	120	0.23	2.7	-	-	-	-	-	-	50	0.20	2.2	-	-	-
	T7335	0.4	155	0.25	2.0	120	0.23	2.0	-	-	-	-	-	-	50	0.20	1.6	-	-	-
	T8330	0.4	140	0.25	2.0	80	0.23	2.0	-	-	-	-	-	-	35	0.20	1.6	-	-	-
	T8430	0.4	150	0.25	2.7	80	0.23	2.7	-	-	-	-	-	-	30	0.20	2.2	-	-	-
	T9315	0.4	215	0.25	2.0	-	-	-	-	-	-	-	-	-	-	-	-	-	-	-
	T9325	0.4	190	0.25	2.0	110	0.23	2.0	-	-	-	-	-	-	40	0.20	1.6	-	-	-
CNMG 120408E-NMR	T6310	0.8	150	0.35	2.7	105	0.32	2.7	-	-	-	-	-	-	45	0.25	2.2	-	-	-
	T7325	0.8	170	0.35	2.7	130	0.32	2.7	-	-	-	-	-	-	55	0.25	2.2	-	-	-
	T7335	0.8	160	0.35	2.7	120	0.32	2.7	-	-	-	-	-	-	50	0.25	2.2	-	-	-
	T8330	0.8	150	0.35	2.7	90	0.32	2.7	-	-	-	-	-	-	35	0.25	2.2	-	-	-
	T8430	0.8	155	0.35	2.7	85	0.32	2.7	-	-	-	-	-	-	30	0.25	2.2	-	-	-
	T9315	0.8	210	0.35	2.7	-	-	-	-	-	-	-	-	-	-	-	-	-	-	-
	T9325	0.8	190	0.35	2.7	110	0.32	2.7	-	-	-	-	-	-	40	0.25	2.2	-	-	-
CNMG 120412E-NMR	T6310	1.2	150	0.40	2.7	105	0.36	2.7	-	-	-	-	-	-	45	0.28	2.2	-	-	-
	T7325	1.2	170	0.40	2.7	130	0.36	2.7	-	-	-	-	-	-	55	0.28	2.2	-	-	-
	T7335	1.2	160	0.40	2.7	120	0.36	2.7	-	-	-	-	-	-	50	0.28	2.2	-	-	-
	T8330	1.2	150	0.40	2.7	90	0.36	2.7	-	-	-	-	-	-	35	0.28	2.2	-	-	-
	T8430	1.2	155	0.40	2.7	85	0.36	2.7	-	-	-	-	-	-	30	0.28	2.2	-	-	-
	T9315	1.2	215	0.40	2.7	-	-	-	-	-	-	-	-	-	-	-	-	-	-	-
CNMG 120416E-NMR	T9325	1.2	190	0.40	2.7	110	0.36	2.7	-	-	-	-	-	-	40	0.28	2.2	-	-	-
	T7325	1.6	170	0.45	2.7	130	0.41	2.7	-	-	-	-	-	-	55	0.32	2.2	-	-	-
	T7335	1.6	160	0.45	2.7	120	0.41	2.7	-	-	-	-	-	-	50	0.32	2.2	-	-	-
CNMG 160608E-NMR	T9325	1.6	190	0.45	2.7	110	0.41	2.7	-	-	-	-	-	-	40	0.32	2.2	-	-	-
	T7325	0.8	160	0.35	4.0	120	0.32	4.0	-	-	-	-	-	-	50	0.25	3.2	-	-	-
	T7335	0.8	150	0.35	4.0	115	0.32	4.0	-	-	-	-	-	-	45	0.25	3.2	-	-	-
	T9315	0.8	205	0.35	4.0	-	-	-	-	-	-	-	-	-	-	-	-	-	-	-
CNMG 160612E-NMR	T9325	0.8	185	0.35	4.0	110	0.32	4.0	-	-	-	-	-	-	40	0.25	3.2	-	-	-
	T7325	1.2	165	0.40	4.0	125	0.36	4.0	-	-	-	-	-	-	50	0.28	3.2	-	-	-
	T7335	1.2	155	0.40	4.0	120	0.36	4.0	-	-	-	-	-	-	50	0.28	3.2	-	-	-
	T8330	1.2	145	0.40	4.0	85	0.36	4.0	-	-	-	-	-	-	35	0.28	3.2	-	-	-
	T8430	1.2	150	0.40	4.0	80	0.36	4.0	-	-	-	-	-	-	30	0.28	3.2	-	-	-
	T9315	1.2	205	0.40	4.0	-	-	-	-	-	-	-	-	-	-	-	-	-	-	-
	T9325	1.2	185	0.40	4.0	110	0.36	4.0	-	-	-	-	-	-	40	0.28	3.2	-	-	-



Kesme hızı (vc), ilerleme (f) ve kesme derinliği (ap) için uygunluk ve başlangıç değerleri. Daha ileri hesaplamalar için İşleme Hesaplayıcısı uygulamasına başvurun.

Product	RE (mm)	P			M			K			N			S			H		
		vc (m/min)	f (mm/rev)	ap (mm)	vc (m/min)	f (mm/rev)	ap (mm)	vc (m/min)	f (mm/rev)	ap (mm)	vc (m/min)	f (mm/rev)	ap (mm)	vc (m/min)	f (mm/rev)	ap (mm)	vc (m/min)	f (mm/rev)	ap (mm)

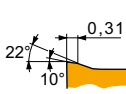

NMR geometri, ortadan kabaya kadar işlemek için pozitif tasarım, darbesiz kesim için uygun.

CNMG 160616E-NMR	T7325	1.6	165	0.45	4.0	125	0.41	4.0	-	-	-	-	-	-	50	0.32	3.2	-	-	-
	T7335	1.6	155	0.45	4.0	120	0.41	4.0	-	-	-	-	-	-	50	0.32	3.2	-	-	-
	T8330	1.6	145	0.45	4.0	85	0.41	4.0	-	-	-	-	-	-	35	0.32	3.2	-	-	-
	T8430	1.6	150	0.45	4.0	80	0.41	4.0	-	-	-	-	-	-	30	0.32	3.2	-	-	-
	T9315	1.6	200	0.45	4.0	-	-	-	-	-	-	-	-	-	-	-	-	-	-	-
CNMG 190608E-NMR	T9325	1.6	180	0.45	4.0	105	0.41	4.0	-	-	-	-	-	-	40	0.32	3.2	-	-	-
	T6310	0.8	140	0.35	5.2	100	0.32	5.2	-	-	-	-	-	-	40	0.25	4.2	-	-	-
	T7325	0.8	155	0.35	5.2	120	0.32	5.2	-	-	-	-	-	-	50	0.25	4.2	-	-	-
	T7335	0.8	150	0.35	5.2	115	0.32	5.2	-	-	-	-	-	-	45	0.25	4.2	-	-	-
	T9315	0.8	195	0.35	5.2	-	-	-	-	-	-	-	-	-	-	-	-	-	-	-
CNMG 190612E-NMR	T9325	0.8	180	0.35	5.2	105	0.32	5.2	-	-	-	-	-	-	40	0.25	4.2	-	-	-
	T6310	1.2	140	0.40	5.2	100	0.36	5.2	-	-	-	-	-	-	40	0.28	4.2	-	-	-
	T7325	1.2	160	0.40	5.2	120	0.36	5.2	-	-	-	-	-	-	50	0.28	4.2	-	-	-
	T7335	1.2	150	0.40	5.2	115	0.36	5.2	-	-	-	-	-	-	45	0.28	4.2	-	-	-
	T8330	1.2	140	0.40	5.2	80	0.36	5.2	-	-	-	-	-	-	35	0.28	4.2	-	-	-
	T8430	1.2	145	0.40	5.2	80	0.36	5.2	-	-	-	-	-	-	30	0.28	4.2	-	-	-
	T9315	1.2	200	0.40	5.2	-	-	-	-	-	-	-	-	-	-	-	-	-	-	-
CNMG 190616E-NMR	T9325	1.2	180	0.40	5.2	105	0.36	5.2	-	-	-	-	-	-	40	0.28	4.2	-	-	-
	T7325	1.6	160	0.45	5.2	120	0.41	5.2	-	-	-	-	-	-	50	0.32	4.2	-	-	-
	T7335	1.6	150	0.45	5.2	115	0.41	5.2	-	-	-	-	-	-	45	0.32	4.2	-	-	-
	T9315	1.6	195	0.45	5.2	-	-	-	-	-	-	-	-	-	-	-	-	-	-	-
	T9325	1.6	175	0.45	5.2	105	0.41	5.2	-	-	-	-	-	-	35	0.32	4.2	-	-	-

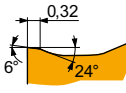

NRM geometri, orta kabadan kabaya kadar işlemek için pozitif tasarım, darbesizden darbeli kesime kadar uygun.

CNMG 120408-NRM	T7325	0.8	160	0.35	4.0	120	0.32	4.0	-	-	-	-	-	-	50	0.28	3.2	-	-	-
	T7335	0.8	150	0.35	4.0	115	0.32	4.0	-	-	-	-	-	-	45	0.28	3.2	-	-	-
	T9315	0.8	205	0.35	4.0	-	-	-	-	-	-	-	-	-	-	-	-	-	-	-
CNMG 120412-NRM	T7325	1.2	165	0.40	4.0	125	0.36	4.0	-	-	-	-	-	-	50	0.28	3.2	-	-	-
	T7335	1.2	155	0.40	4.0	120	0.36	4.0	-	-	-	-	-	-	50	0.28	3.2	-	-	-
	T9315	1.2	205	0.40	4.0	-	-	-	-	-	-	-	-	-	-	-	-	-	-	-
CNMG 120416-NRM	T7325	1.6	165	0.45	4.0	125	0.41	4.0	-	-	-	-	-	-	50	0.36	3.2	-	-	-
	T7335	1.6	155	0.45	4.0	120	0.41	4.0	-	-	-	-	-	-	50	0.36	3.2	-	-	-
	T9315	1.6	200	0.45	4.0	-	-	-	-	-	-	-	-	-	-	-	-	-	-	-
CNMG 160608-NRM	T7325	0.8	155	0.35	6.0	120	0.32	6.0	-	-	-	-	-	-	50	0.28	4.8	-	-	-
	T7335	0.8	145	0.35	6.0	110	0.32	6.0	-	-	-	-	-	-	45	0.28	4.8	-	-	-
	T9315	0.8	195	0.35	6.0	-	-	-	-	-	-	-	-	-	-	-	-	-	-	-
CNMG 160612-NRM	T7325	1.2	155	0.40	6.0	120	0.36	6.0	-	-	-	-	-	-	50	0.32	4.8	-	-	-
	T7335	1.2	150	0.40	6.0	115	0.36	6.0	-	-	-	-	-	-	45	0.32	4.8	-	-	-
	T9315	1.2	200	0.40	6.0	-	-	-	-	-	-	-	-	-	-	-	-	-	-	-
CNMG 160616-NRM	T7325	1.6	155	0.45	6.0	120	0.41	6.0	-	-	-	-	-	-	50	0.36	4.8	-	-	-
	T7335	1.6	150	0.45	6.0	115	0.41	6.0	-	-	-	-	-	-	45	0.36	4.8	-	-	-
	T9315	1.6	195	0.45	6.0	-	-	-	-	-	-	-	-	-	-	-	-	-	-	-
CNMG 190608-NRM	T7325	0.8	150	0.35	8.0	115	0.32	8.0	-	-	-	-	-	-	45	0.28	6.4	-	-	-
	T7335	0.8	140	0.35	8.0	105	0.32	8.0	-	-	-	-	-	-	45	0.28	6.4	-	-	-
	T9315	0.8	190	0.35	8.0	-	-	-	-	-	-	-	-	-	-	-	-	-	-	-
CNMG 190612-NRM	T7325	1.2	155	0.40	8.0	120	0.36	8.0	-	-	-	-	-	-	50	0.32	6.4	-	-	-
	T7335	1.2	145	0.40	8.0	110	0.36	8.0	-	-	-	-	-	-	45	0.32	6.4	-	-	-
	T9315	1.2	190	0.40	8.0	-	-	-	-	-	-	-	-	-	-	-	-	-	-	-
CNMG 190616-NRM	T7325	1.6	150	0.45	8.0	115	0.41	8.0	-	-	-	-	-	-	45	0.36	6.4	-	-	-
	T7335	1.6	145	0.45	8.0	110	0.41	8.0	-	-	-	-	-	-	45	0.36	6.4	-	-	-
	T9315	1.6	190	0.45	8.0	-	-	-	-	-	-	-	-	-	-	-	-	-	-	-
CNMG 250924-NRM	T7325	2.4	95	0.70	10.0	70	0.63	10.0	-	-	-	-	-	-	30	0.49	8.0	-	-	-
	T7335	2.4	90	0.70	10.0	70	0.63	10.0	-	-	-	-	-	-	25	0.49	8.0	-	-	-
	T9315	2.4	115	0.70	10.0	-	-	-	105	0.70	10.0	-	-	-	-	-	-	-	-	-



Kesme hızı (vc), ilerleme (f) ve kesme derinliği (ap) için uygunluk ve başlangıç değerleri. Daha ileri hesaplamalar için İşleme Hesaplayıcısı uygulamasına başvurun.

Product	RE (mm)	P			M			K			N			S			H		
		vc (m/min)	f (mm/rev)	ap (mm)	vc (m/min)	f (mm/rev)	ap (mm)	vc (m/min)	f (mm/rev)	ap (mm)	vc (m/min)	f (mm/rev)	ap (mm)	vc (m/min)	f (mm/rev)	ap (mm)	vc (m/min)	f (mm/rev)	ap (mm)

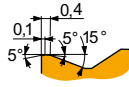

R geometri, orta kabadan kaba işleme kadar, darbesizden darbeli kesime kadar uygun.

CNMG 120408E-R	6640	0.8	■	140	0.40	4.0	–	–	–	■	130	0.40	4.0	–	–	–	–	–	–	
	T5305	0.8	▣	240	0.40	4.0	–	–	–	■	225	0.40	4.0	–	–	–	▣	45	0.15	1.0
	T5315	0.8	▣	215	0.40	4.0	–	–	–	■	200	0.40	4.0	–	–	–	▣	40	0.15	1.0
	T9310	0.8	■	205	0.40	4.0	–	–	–	▣	190	0.40	4.0	–	–	–	▣	40	0.15	1.0
	T9315	0.8	■	190	0.40	4.0	–	–	–	▣	180	0.40	4.0	–	–	–	▣	35	0.15	1.0
	T9325	0.8	■	175	0.40	4.0	–	–	–	▣	165	0.40	4.0	–	–	–	–	–	–	–
	T9335	0.8	■	150	0.40	4.0	–	–	–	–	–	–	–	–	–	–	–	–	–	–
CNMG 120412E-R	T5305	1.2	▣	245	0.45	4.0	–	–	–	■	230	0.45	4.0	–	–	–	▣	45	0.15	1.0
	T5315	1.2	▣	220	0.45	4.0	–	–	–	■	205	0.45	4.0	–	–	–	▣	40	0.15	1.0
	T9315	1.2	■	195	0.45	4.0	–	–	–	▣	185	0.45	4.0	–	–	–	▣	35	0.15	1.0
	T9325	1.2	■	175	0.45	4.0	–	–	–	▣	165	0.45	4.0	–	–	–	–	–	–	–
	T9335	1.2	■	155	0.45	4.0	–	–	–	–	–	–	–	–	–	–	–	–	–	–
CNMG 120416E-R	T5315	1.6	▣	225	0.50	4.0	–	–	–	■	210	0.50	4.0	–	–	–	▣	45	0.15	1.0
	T9335	1.6	■	150	0.50	4.0	–	–	–	–	–	–	–	–	–	–	–	–	–	–
CNMG 160608E-R	T5315	0.8	▣	210	0.40	5.5	–	–	–	■	195	0.40	5.5	–	–	–	▣	40	0.15	1.0
CNMG 160612E-R	T5305	1.2	▣	235	0.45	5.5	–	–	–	■	220	0.45	5.5	–	–	–	▣	45	0.15	1.0
	T5315	1.2	▣	215	0.45	5.5	–	–	–	■	200	0.45	5.5	–	–	–	▣	40	0.15	1.0
	T7335	1.2	▣	145	0.45	5.5	–	–	–	–	–	–	–	–	–	–	–	–	–	
	T9310	1.2	■	205	0.45	5.5	–	–	–	▣	190	0.45	5.5	–	–	–	▣	40	0.15	1.0
	T9315	1.2	■	190	0.45	5.5	–	–	–	▣	180	0.45	5.5	–	–	–	▣	35	0.15	1.0
	T9325	1.2	■	170	0.45	5.5	–	–	–	▣	160	0.45	5.5	–	–	–	–	–	–	–
	T9335	1.2	■	150	0.45	5.5	–	–	–	–	–	–	–	–	–	–	–	–	–	–
CNMG 160616E-R	T5305	1.6	▣	240	0.50	5.5	–	–	–	■	225	0.50	5.5	–	–	–	▣	45	0.15	1.0
CNMG 190608E-R	T5315	0.8	▣	205	0.40	7.0	–	–	–	■	190	0.40	7.0	–	–	–	▣	40	0.15	1.0
CNMG 190612E-R	6640	1.2	■	135	0.45	7.0	–	–	–	■	125	0.45	7.0	–	–	–	–	–	–	–
	T5305	1.2	▣	230	0.45	7.0	–	–	–	■	215	0.45	7.0	–	–	–	▣	45	0.15	1.0
	T5315	1.2	▣	210	0.45	7.0	–	–	–	■	195	0.45	7.0	–	–	–	▣	40	0.15	1.0
	T9315	1.2	■	185	0.45	7.0	–	–	–	▣	175	0.45	7.0	–	–	–	▣	35	0.15	1.0
	T9325	1.2	■	165	0.45	7.0	–	–	–	▣	155	0.45	7.0	–	–	–	–	–	–	–
	T9335	1.2	■	145	0.45	7.0	–	–	–	–	–	–	–	–	–	–	–	–	–	–
CNMG 190616E-R	6640	1.6	■	130	0.50	7.0	–	–	–	■	120	0.50	7.0	–	–	–	–	–	–	–
	T5305	1.6	▣	235	0.50	7.0	–	–	–	■	220	0.50	7.0	–	–	–	▣	45	0.15	1.0
	T5315	1.6	▣	210	0.50	7.0	–	–	–	■	195	0.50	7.0	–	–	–	▣	40	0.15	1.0
	T9310	1.6	■	195	0.50	7.0	–	–	–	▣	185	0.50	7.0	–	–	–	▣	35	0.15	1.0
	T9315	1.6	■	180	0.50	7.0	–	–	–	▣	170	0.50	7.0	–	–	–	▣	35	0.15	1.0
	T9325	1.6	■	165	0.50	7.0	–	–	–	▣	155	0.50	7.0	–	–	–	–	–	–	–
	T9335	1.6	■	145	0.50	7.0	–	–	–	–	–	–	–	–	–	–	–	–	–	–

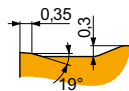

RM geometri, yarı kabadan kaba işleme kadar, ve darbesizden darbeli kesime kadar uygun.

CNMG 120408E-RM	T5305	0.8	▣	275	0.40	4.0	–	–	–	▣	260	0.40	4.0	–	–	–	–	–	–		
	T5315	0.8	▣	250	0.40	4.0	–	–	–	▣	235	0.40	4.0	–	–	–	–	–	–	–	
	T6310	0.8	■	155	0.40	4.0	▣	110	0.36	4.0	▣	125	0.40	4.0	–	–	–	–	–	–	
	T7325	0.8	▣	180	0.40	4.0	▣	140	0.36	4.0	–	–	–	–	–	–	–	–	–	–	
	T7335	0.8	▣	165	0.40	4.0	▣	125	0.36	4.0	–	–	–	–	–	–	–	–	–	–	
	T8315	0.8	▣	165	0.40	4.0	▣	95	0.36	4.0	▣	155	0.40	4.0	–	–	–	–	–	–	–
	T8330	0.8	■	155	0.40	4.0	▣	90	0.36	4.0	▣	145	0.40	4.0	–	–	–	–	–	–	–
	T8430	0.8	■	165	0.40	4.0	▣	90	0.36	4.0	▣	135	0.40	4.0	–	–	–	–	–	–	–
	T9310	0.8	■	240	0.40	4.0	–	–	–	▣	225	0.40	4.0	–	–	–	–	–	–	–	–
	T9315	0.8	■	220	0.40	4.0	–	–	–	▣	205	0.40	4.0	–	–	–	–	–	–	–	–
	T9325	0.8	■	200	0.40	4.0	▣	120	0.36	4.0	▣	190	0.40	4.0	–	–	–	–	–	–	–
	T9335	0.8	■	170	0.40	4.0	▣	100	0.36	4.0	–	–	–	–	–	–	–	–	–	–	–



Kesme hızı (vc), ilerleme (f) ve kesme derinliği (ap) için uygunluk ve başlangıç değerleri. Daha ileri hesaplamalar için İşleme Hesaplayıcısı uygulamasına başvurun.

Product	RE  (mm)	P			M			K			N			S			H		
		vc (m/min)	f (mm/rev)	ap (mm)	vc (m/min)	f (mm/rev)	ap (mm)	vc (m/min)	f (mm/rev)	ap (mm)	vc (m/min)	f (mm/rev)	ap (mm)	vc (m/min)	f (mm/rev)	ap (mm)	vc (m/min)	f (mm/rev)	ap (mm)

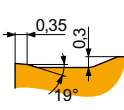

RM geometri, yarı kabadan kaba işleme kadar, ve darbesizden darbeli kesime kadar uygun.

CNMG 120412E-RM	T5305	1.2	280	0.45	4.0	-	-	-	265	0.45	4.0	-	-	-	-	-	-	-
	T5315	1.2	250	0.45	4.0	-	-	-	235	0.45	4.0	-	-	-	-	-	-	-
	T6310	1.2	160	0.45	4.0	115	0.41	4.0	125	0.45	4.0	-	-	-	-	-	-	-
	T7325	1.2	180	0.45	4.0	140	0.41	4.0	-	-	-	-	-	-	-	-	-	-
	T7335	1.2	170	0.45	4.0	130	0.41	4.0	-	-	-	-	-	-	-	-	-	-
	T8315	1.2	170	0.45	4.0	100	0.41	4.0	160	0.45	4.0	-	-	-	-	-	-	-
	T8330	1.2	160	0.45	4.0	95	0.41	4.0	150	0.45	4.0	-	-	-	-	-	-	-
	T8430	1.2	170	0.45	4.0	90	0.41	4.0	135	0.45	4.0	-	-	-	-	-	-	-
	T9310	1.2	240	0.45	4.0	-	-	-	225	0.45	4.0	-	-	-	-	-	-	-
	T9315	1.2	220	0.45	4.0	-	-	-	205	0.45	4.0	-	-	-	-	-	-	-
	T9325	1.2	200	0.45	4.0	120	0.41	4.0	190	0.45	4.0	-	-	-	-	-	-	-
	T9335	1.2	175	0.45	4.0	105	0.41	4.0	-	-	-	-	-	-	-	-	-	-
CNMG 120416E-RM	T5305	1.6	280	0.50	4.0	-	-	-	265	0.50	4.0	-	-	-	-	-	-	-
	T5315	1.6	255	0.50	4.0	-	-	-	240	0.50	4.0	-	-	-	-	-	-	-
	T7325	1.6	185	0.50	4.0	140	0.45	4.0	-	-	-	-	-	-	-	-	-	
	T7335	1.6	175	0.50	4.0	135	0.45	4.0	-	-	-	-	-	-	-	-	-	
	T8330	1.6	160	0.50	4.0	95	0.45	4.0	150	0.50	4.0	-	-	-	-	-	-	
	T8430	1.6	170	0.50	4.0	90	0.45	4.0	135	0.50	4.0	-	-	-	-	-	-	
	T9310	1.6	240	0.50	4.0	-	-	-	225	0.50	4.0	-	-	-	-	-	-	
	T9315	1.6	220	0.50	4.0	-	-	-	205	0.50	4.0	-	-	-	-	-	-	
	T9325	1.6	205	0.50	4.0	120	0.45	4.0	190	0.50	4.0	-	-	-	-	-	-	
T9335	1.6	175	0.50	4.0	105	0.45	4.0	-	-	-	-	-	-	-	-	-		
CNMG 160608E-RM	T5305	0.8	265	0.40	6.0	-	-	-	250	0.40	6.0	-	-	-	-	-	-	
	T5315	0.8	240	0.40	6.0	-	-	-	225	0.40	6.0	-	-	-	-	-	-	
	T8330	0.8	150	0.40	6.0	90	0.36	6.0	140	0.40	6.0	-	-	-	-	-		
	T8430	0.8	155	0.40	6.0	85	0.36	6.0	130	0.40	6.0	-	-	-	-	-		
	T9315	0.8	215	0.40	6.0	-	-	-	200	0.40	6.0	-	-	-	-	-		
	T9325	0.8	190	0.40	6.0	110	0.36	6.0	180	0.40	6.0	-	-	-	-	-		
	T9335	0.8	165	0.40	6.0	95	0.36	6.0	-	-	-	-	-	-	-			
CNMG 160612E-RM	T5305	1.2	270	0.45	6.0	-	-	-	255	0.45	6.0	-	-	-	-	-	-	
	T5315	1.2	245	0.45	6.0	-	-	-	230	0.45	6.0	-	-	-	-	-		
	T6310	1.2	155	0.45	6.0	110	0.41	6.0	125	0.45	6.0	-	-	-	-	-		
	T7325	1.2	170	0.45	6.0	130	0.41	6.0	-	-	-	-	-	-	-			
	T7335	1.2	165	0.45	6.0	125	0.41	6.0	-	-	-	-	-	-				
	T8330	1.2	155	0.45	6.0	90	0.41	6.0	145	0.45	6.0	-	-	-				
	T8430	1.2	155	0.45	6.0	85	0.41	6.0	130	0.45	6.0	-	-	-				
	T9310	1.2	230	0.45	6.0	-	-	-	215	0.45	6.0	-	-	-				
	T9315	1.2	215	0.45	6.0	-	-	-	200	0.45	6.0	-	-	-				
	T9325	1.2	195	0.45	6.0	115	0.41	6.0	185	0.45	6.0	-	-	-				
	T9335	1.2	165	0.45	6.0	95	0.41	6.0	-	-	-	-	-					
CNMG 160616E-RM	T5305	1.6	270	0.50	6.0	-	-	-	255	0.50	6.0	-	-	-	-	-		
	T5315	1.6	245	0.50	6.0	-	-	-	230	0.50	6.0	-	-	-	-			
	T7325	1.6	175	0.50	6.0	135	0.45	6.0	-	-	-	-	-					
	T7335	1.6	165	0.50	6.0	125	0.45	6.0	-	-	-	-	-					
	T9310	1.6	225	0.50	6.0	-	-	-	210	0.50	6.0	-	-					
	T9315	1.6	215	0.50	6.0	-	-	-	200	0.50	6.0	-	-					
	T9325	1.6	190	0.50	6.0	110	0.45	6.0	180	0.50	6.0	-	-					
T9335	1.6	165	0.50	6.0	95	0.45	6.0	-	-	-	-							
CNMG 190608E-RM	T5305	0.8	260	0.40	7.5	-	-	-	245	0.40	7.5	-	-	-	-	-		
	T5315	0.8	230	0.40	7.5	-	-	-	215	0.40	7.5	-	-	-	-			
	T7335	0.8	155	0.40	7.5	120	0.36	7.5	-	-	-	-	-					
	T9315	0.8	210	0.40	7.5	-	-	-	195	0.40	7.5	-	-					
	T9325	0.8	190	0.40	7.5	110	0.36	7.5	180	0.40	7.5	-	-					
	T9335	0.8	160	0.40	7.5	95	0.36	7.5	-	-	-	-						



Kesme hızı (vc), ilerleme (f) ve kesme derinliği (ap) için uygunluk ve başlangıç değerleri. Daha ileri hesaplamalar için İşleme Hesaplayıcısı uygulamasına başvurun.

Product	RE (mm)	P			M			K			N			S			H						
		vc	f	ap	vc	f	ap	vc	f	ap	vc	f	ap	vc	f	ap	vc	f	ap				
		(m/min)	(mm/rev)	(mm)	(m/min)	(mm/rev)	(mm)	(m/min)	(mm/rev)	(mm)	(m/min)	(mm/rev)	(mm)	(m/min)	(mm/rev)	(mm)	(m/min)	(mm/rev)	(mm)	(m/min)	(mm/rev)	(mm)	
CNMG 190612E-RM	T5305	1.2	260	0.45	7.5	–	–	–	245	0.45	7.5	–	–	–	–	–	–	–	–	–	–	–	–
	T5315	1.2	240	0.45	7.5	–	–	–	225	0.45	7.5	–	–	–	–	–	–	–	–	–	–	–	–
	T6310	1.2	155	0.45	7.5	110	0.41	7.5	125	0.45	7.5	–	–	–	–	–	–	–	–	–	–	–	–
	T7325	1.2	170	0.45	7.5	130	0.41	7.5	–	–	–	–	–	–	–	–	–	–	–	–	–	–	–
	T7335	1.2	160	0.45	7.5	120	0.41	7.5	–	–	–	–	–	–	–	–	–	–	–	–	–	–	–
	T8330	1.2	155	0.45	7.5	90	0.41	7.5	145	0.45	7.5	–	–	–	–	–	–	–	–	–	–	–	–
	T8430	1.2	150	0.45	7.5	80	0.41	7.5	125	0.45	7.5	–	–	–	–	–	–	–	–	–	–	–	–
	T9310	1.2	220	0.45	7.5	–	–	–	205	0.45	7.5	–	–	–	–	–	–	–	–	–	–	–	–
	T9315	1.2	210	0.45	7.5	–	–	–	195	0.45	7.5	–	–	–	–	–	–	–	–	–	–	–	–
	T9325	1.2	185	0.45	7.5	110	0.41	7.5	175	0.45	7.5	–	–	–	–	–	–	–	–	–	–	–	–
T9335	1.2	165	0.45	7.5	95	0.41	7.5	–	–	–	–	–	–	–	–	–	–	–	–	–	–	–	
CNMG 190616E-RM	T5305	1.6	265	0.50	7.5	–	–	–	250	0.50	7.5	–	–	–	–	–	–	–	–	–	–	–	–
	T5315	1.6	240	0.50	7.5	–	–	–	225	0.50	7.5	–	–	–	–	–	–	–	–	–	–	–	–
	T6310	1.6	155	0.50	7.5	110	0.45	7.5	125	0.50	7.5	–	–	–	–	–	–	–	–	–	–	–	–
	T7325	1.6	175	0.50	7.5	135	0.45	7.5	–	–	–	–	–	–	–	–	–	–	–	–	–	–	–
	T7335	1.6	160	0.50	7.5	120	0.45	7.5	–	–	–	–	–	–	–	–	–	–	–	–	–	–	–
	T9310	1.6	225	0.50	7.5	–	–	–	210	0.50	7.5	–	–	–	–	–	–	–	–	–	–	–	–
	T9315	1.6	210	0.50	7.5	–	–	–	195	0.50	7.5	–	–	–	–	–	–	–	–	–	–	–	–
	T9325	1.6	190	0.50	7.5	110	0.45	7.5	180	0.50	7.5	–	–	–	–	–	–	–	–	–	–	–	–
T9335	1.6	160	0.50	7.5	95	0.45	7.5	–	–	–	–	–	–	–	–	–	–	–	–	–	–	–	
CNMG 250924E-RM	T7325	2.4	105	0.80	12.0	80	0.72	12.0	–	–	–	–	–	–	–	–	–	–	–	–	–	–	–
	T7335	2.4	100	0.80	12.0	75	0.72	12.0	–	–	–	–	–	–	–	–	–	–	–	–	–	–	–
	T9226	2.4	90	0.80	12.0	50	0.72	12.0	85	0.80	12.0	–	–	–	–	–	–	–	–	–	–	–	–
	T9315	2.4	120	0.80	12.0	–	–	–	110	0.80	12.0	–	–	–	–	–	–	–	–	–	–	–	–
	T9325	2.4	105	0.80	12.0	60	0.72	12.0	95	0.80	12.0	–	–	–	–	–	–	–	–	–	–	–	–
	T9335	2.4	85	0.80	12.0	50	0.72	12.0	–	–	–	–	–	–	–	–	–	–	–	–	–	–	–

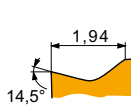

SF geometri, ince finiş ve ince cidar işlemek için pozitif tasarım, darbesiz kesim için uygun.

CNMG 120404E-SF	H07	0.4	–	–	–	90	0.14	1.0	145	0.15	1.0	470	0.18	1.0	45	0.12	0.8	–	–	–	–	–	–		
	T6310	0.4	180	0.15	1.0	125	0.14	1.0	145	0.15	1.0	540	0.18	1.0	50	0.12	0.8	35	0.15	1.0	–	–	–		
	T7325	0.4	205	0.17	1.0	155	0.15	1.0	–	–	–	–	–	–	65	0.15	0.8	–	–	–	–	–	–		
	T7335	0.4	200	0.17	1.0	155	0.15	1.0	–	–	–	–	–	–	65	0.15	0.8	–	–	–	–	–	–	–	
	T8315	0.4	195	0.15	1.0	115	0.14	1.0	185	0.15	1.0	585	0.18	1.0	45	0.12	0.8	35	0.15	1.0	–	–	–	–	
	T8330	0.4	180	0.15	1.0	105	0.14	1.0	170	0.15	1.0	540	0.18	1.0	45	0.12	0.8	35	0.15	1.0	–	–	–	–	
	T8430	0.4	220	0.15	1.0	120	0.14	1.0	180	0.15	1.0	600	0.18	1.0	45	0.12	0.8	35	0.15	1.0	–	–	–	–	
	T9315	0.4	300	0.15	1.0	–	–	–	285	0.15	1.0	–	–	–	–	–	–	60	0.15	1.0	–	–	–	–	
	T9325	0.4	255	0.17	1.0	150	0.15	1.0	240	0.17	1.0	–	–	–	55	0.15	0.8	–	–	–	–	–	–	–	
CNMG 120408E-SF	H07	0.8	–	–	–	95	0.18	1.0	155	0.20	1.0	495	0.24	1.0	50	0.14	0.8	–	–	–	–	–	–	–	
	T6310	0.8	200	0.20	1.0	140	0.18	1.0	160	0.20	1.0	600	0.24	1.0	60	0.14	0.8	40	0.15	1.0	–	–	–	–	
	T7325	0.8	230	0.20	1.0	175	0.18	1.0	–	–	–	–	–	–	70	0.16	0.8	–	–	–	–	–	–	–	
	T7335	0.8	220	0.20	1.0	170	0.18	1.0	–	–	–	–	–	–	70	0.16	0.8	–	–	–	–	–	–	–	–
	T8315	0.8	210	0.20	1.0	125	0.18	1.0	195	0.20	1.0	630	0.24	1.0	50	0.14	0.8	40	0.15	1.0	–	–	–	–	
	T8330	0.8	200	0.20	1.0	120	0.18	1.0	190	0.20	1.0	600	0.24	1.0	50	0.14	0.8	40	0.15	1.0	–	–	–	–	
	T8430	0.8	230	0.20	1.0	125	0.18	1.0	185	0.20	1.0	630	0.24	1.0	45	0.14	0.8	35	0.15	1.0	–	–	–	–	
	T9315	0.8	315	0.20	1.0	–	–	–	295	0.20	1.0	–	–	–	–	–	–	60	0.15	1.0	–	–	–	–	
T9325	0.8	280	0.20	1.0	165	0.18	1.0	265	0.20	1.0	–	–	–	60	0.16	0.8	–	–	–	–	–	–	–		
CNMG 120412E-SF	T6310	1.2	190	0.25	1.5	135	0.23	1.5	150	0.25	1.5	570	0.30	1.5	55	0.18	1.2	35	0.15	1.0	–	–	–	–	
	T7325	1.2	220	0.25	1.5	170	0.23	1.5	–	–	–	–	–	–	70	0.18	1.2	–	–	–	–	–	–		
	T8315	1.2	200	0.25	1.5	120	0.23	1.5	190	0.25	1.5	600	0.30	1.5	50	0.18	1.2	40	0.15	1.0	–	–	–	–	
	T8430	1.2	210	0.25	1.5	115	0.23	1.5	175	0.25	1.5	585	0.30	1.5	45	0.18	1.2	35	0.15	1.0	–	–	–	–	



Kesme hızı (vc), ilerleme (f) ve kesme derinliği (ap) için uygunluk ve başlangıç değerleri. Daha ileri hesaplamalar için İşleme Hesaplayıcısı uygulamasına başvurun.

Product	RE  (mm)	P			M			K			N			S			H		
		vc (m/min)	f (mm/rev)	ap (mm)	vc (m/min)	f (mm/rev)	ap (mm)	vc (m/min)	f (mm/rev)	ap (mm)	vc (m/min)	f (mm/rev)	ap (mm)	vc (m/min)	f (mm/rev)	ap (mm)	vc (m/min)	f (mm/rev)	ap (mm)

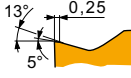

SM geometri, orta işleme için pozitif tasarım, darbesizden darbeli kesime kadar uygun.

CNMG 120404E-SM	T6310	0.4	■	155	0.22	2.0	■	110	0.20	2.0	■	125	0.22	2.0	▣	465	0.26	2.0	■	45	0.20	1.6	▣	30	0.15	1.0
	T7325	0.4	▣	175	0.22	2.0	■	135	0.20	2.0	■	-	-	-	-	-	-	-	■	55	0.20	1.6	-	-	-	
	T7335	0.4	▣	170	0.22	2.0	■	130	0.20	2.0	■	-	-	-	-	-	-	-	■	55	0.20	1.6	-	-	-	
	T8330	0.4	■	155	0.22	2.0	■	90	0.20	2.0	■	145	0.22	2.0	▣	465	0.26	2.0	▣	35	0.20	1.6	▣	30	0.15	1.0
	T8430	0.4	■	170	0.22	2.0	■	90	0.20	2.0	▣	135	0.22	2.0	▣	465	0.26	2.0	▣	35	0.20	1.6	▣	25	0.15	1.0
	T9315	0.4	■	245	0.20	2.0	■	-	-	-	▣	230	0.20	2.0	-	-	-	-	-	▣	45	0.15	1.0	-	-	-
	T9325	0.4	■	210	0.22	2.0	■	125	0.20	2.0	▣	195	0.22	2.0	-	-	-	-	-	▣	45	0.20	1.6	-	-	-
CNMG 120408E-SM	T6310	0.8	■	175	0.25	2.0	■	125	0.23	2.0	■	140	0.25	2.0	▣	525	0.30	2.0	■	50	0.20	1.6	▣	35	0.15	1.0
	T7325	0.8	▣	200	0.25	2.0	■	155	0.23	2.0	■	-	-	-	-	-	-	-	■	65	0.20	1.6	-	-	-	
	T7335	0.8	▣	190	0.25	2.0	■	145	0.23	2.0	■	-	-	-	-	-	-	-	■	60	0.20	1.6	-	-	-	
	T8330	0.8	■	175	0.25	2.0	■	105	0.23	2.0	■	165	0.25	2.0	▣	525	0.30	2.0	▣	40	0.20	1.6	▣	35	0.15	1.0
	T8430	0.8	■	195	0.25	2.0	■	105	0.23	2.0	▣	160	0.25	2.0	▣	540	0.30	2.0	▣	40	0.20	1.6	▣	30	0.15	1.0
	T9315	0.8	■	265	0.25	2.0	■	-	-	-	▣	250	0.25	2.0	-	-	-	-	-	▣	50	0.15	1.0	-	-	-
	T9325	0.8	■	235	0.25	2.0	■	140	0.23	2.0	▣	220	0.25	2.0	-	-	-	-	-	▣	50	0.20	1.6	-	-	-
CNMG 120412E-SM	T6310	1.2	■	175	0.30	2.0	■	125	0.27	2.0	■	140	0.30	2.0	▣	525	0.36	2.0	■	50	0.24	1.6	▣	35	0.15	1.0
	T7325	1.2	▣	195	0.30	2.0	■	150	0.27	2.0	■	-	-	-	-	-	-	-	■	60	0.24	1.6	-	-	-	
	T7335	1.2	▣	190	0.30	2.0	■	145	0.27	2.0	■	-	-	-	-	-	-	-	■	60	0.24	1.6	-	-	-	
	T8330	1.2	■	175	0.30	2.0	■	105	0.27	2.0	■	165	0.30	2.0	▣	525	0.36	2.0	▣	40	0.24	1.6	▣	35	0.15	1.0
	T8430	1.2	■	190	0.30	2.0	■	105	0.27	2.0	▣	155	0.30	2.0	▣	525	0.36	2.0	▣	40	0.24	1.6	▣	30	0.15	1.0
	T9315	1.2	■	260	0.30	2.0	■	-	-	-	▣	245	0.30	2.0	-	-	-	-	-	▣	50	0.15	1.0	-	-	-
	T9325	1.2	■	235	0.30	2.0	■	140	0.27	2.0	▣	220	0.30	2.0	-	-	-	-	-	▣	50	0.24	1.6	-	-	-
CNMG 160608E-SM	T7325	0.8	▣	185	0.26	3.0	■	140	0.23	3.0	■	-	-	-	-	-	-	-	■	60	0.23	2.4	-	-	-	
	T7335	0.8	▣	180	0.26	3.0	■	140	0.23	3.0	■	-	-	-	-	-	-	-	■	55	0.23	2.4	-	-	-	
	T8330	0.8	■	165	0.26	3.0	■	95	0.23	3.0	■	155	0.26	3.0	▣	495	0.31	3.0	▣	40	0.23	2.4	▣	30	0.15	1.0
	T8430	0.8	■	180	0.26	3.0	■	95	0.23	3.0	▣	145	0.26	3.0	▣	495	0.31	3.0	▣	35	0.23	2.4	▣	30	0.15	1.0
	T9325	0.8	■	225	0.26	3.0	■	135	0.23	3.0	▣	210	0.26	3.0	-	-	-	-	▣	50	0.23	2.4	-	-	-	
CNMG 160612E-SM	T6310	1.2	■	170	0.30	3.0	■	120	0.27	3.0	■	135	0.30	3.0	▣	510	0.36	3.0	■	50	0.27	2.4	▣	30	0.15	1.0
	T7325	1.2	▣	190	0.30	3.0	■	145	0.27	3.0	■	-	-	-	-	-	-	-	■	60	0.27	2.4	-	-	-	
	T7335	1.2	▣	180	0.30	3.0	■	140	0.27	3.0	■	-	-	-	-	-	-	-	■	55	0.27	2.4	-	-	-	
	T9315	1.2	■	250	0.30	3.0	■	-	-	-	▣	235	0.30	3.0	-	-	-	-	-	▣	50	0.15	1.0	-	-	-
	T9325	1.2	■	225	0.30	3.0	■	135	0.27	3.0	▣	210	0.30	3.0	-	-	-	-	-	▣	50	0.27	2.4	-	-	-
CNMG 190612E-SM	T6310	1.2	■	165	0.30	4.0	■	115	0.27	4.0	■	130	0.30	4.0	▣	495	0.36	4.0	■	45	0.27	3.2	▣	30	0.15	1.0
	T7325	1.2	▣	185	0.30	4.0	■	140	0.27	4.0	■	-	-	-	-	-	-	-	■	60	0.27	3.2	-	-	-	
	T7335	1.2	▣	175	0.30	4.0	■	135	0.27	4.0	■	-	-	-	-	-	-	-	■	55	0.27	3.2	-	-	-	
	T9315	1.2	■	245	0.30	4.0	■	-	-	-	▣	230	0.30	4.0	-	-	-	-	-	▣	45	0.15	1.0	-	-	-
	T9325	1.2	■	220	0.30	4.0	■	130	0.27	4.0	▣	205	0.30	4.0	-	-	-	-	-	▣	45	0.27	3.2	-	-	-

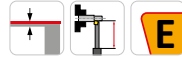
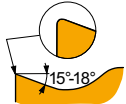

ER-SI geometri, çok pozitif sağ kesme yönlü tasarım, ince finiştten yarı kaba işleme kadar, ve darbesiz kesim için uygun.

CNMG 120404ER-SI	T7325	0.4	▣	220	0.20	1.7	■	170	0.18	1.7	■	-	-	-	-	-	-	-	▣	70	0.18	1.4	-	-	-
	T7335	0.4	▣	215	0.20	1.7	■	165	0.18	1.7	■	-	-	-	-	-	-	-	▣	65	0.18	1.4	-	-	-
	T8330	0.4	■	195	0.20	1.7	■	115	0.18	1.7	■	-	-	-	▣	585	0.24	1.7	▣	45	0.18	1.4	-	-	-
	T8430	0.4	■	225	0.20	1.7	■	120	0.18	1.7	■	-	-	-	▣	615	0.24	1.7	▣	45	0.18	1.4	-	-	-
	T9325	0.4	■	270	0.20	1.7	■	160	0.18	1.7	■	-	-	-	-	-	-	-	▣	60	0.18	1.4	-	-	-
CNMG 120408ER-SI	T7325	0.8	▣	215	0.35	1.7	■	165	0.32	1.7	■	-	-	-	-	-	-	-	▣	65	0.25	1.4	-	-	-
	T7335	0.8	▣	205	0.35	1.7	■	155	0.32	1.7	■	-	-	-	-	-	-	-	▣	65	0.25	1.4	-	-	-
	T8315	0.8	▣	205	0.35	1.7	■	120	0.32	1.7	■	-	-	-	▣	615	0.42	1.7	▣	50	0.25	1.4	-	-	-
	T8330	0.8	■	195	0.35	1.7	■	115	0.32	1.7	■	-	-	-	▣	585	0.42	1.7	▣	45	0.25	1.4	-	-	-
	T8430	0.8	■	210	0.35	1.7	■	115	0.32	1.7	■	-	-	-	▣	585	0.42	1.7	▣	45	0.25	1.4	-	-	-
CNMG 120412ER-SI	T9325	0.8	■	255	0.35	1.7	■	150	0.32	1.7	■	-	-	-	-	-	-	-	▣	55	0.25	1.4	-	-	-
	T8430	1.2	■	225	0.35	1.7	■	120	0.32	1.7	■	-	-	-	▣	615	0.42	1.7	▣	45	0.25	1.4	-	-	-



Kesme hızı (vc), ilerleme (f) ve kesme derinliği (ap) için uygunluk ve başlangıç değerleri. Daha ileri hesaplamalar için İşleme Hesaplayıcısı uygulamasına başvurun.

Product	RE (mm)	P			M			K			N			S			H		
		vc (m/min)	f (mm/rev)	ap (mm)	vc (m/min)	f (mm/rev)	ap (mm)	vc (m/min)	f (mm/rev)	ap (mm)	vc (m/min)	f (mm/rev)	ap (mm)	vc (m/min)	f (mm/rev)	ap (mm)	vc (m/min)	f (mm/rev)	ap (mm)

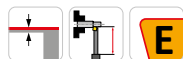
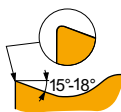

EL-SI geometri, çok pozitif sol kesme yönlü tasarım, ince finişten yarı kaba işleme kadar, ve darbesiz kesim için uygun.

CNMG 120404EL-SI	T7325	0.4	220	0.20	1.7	170	0.18	1.7	-	-	-	-	-	70	0.18	1.4	-	-	-	
	T7335	0.4	215	0.20	1.7	165	0.18	1.7	-	-	-	-	-	65	0.18	1.4	-	-	-	
	T8330	0.4	195	0.20	1.7	115	0.18	1.7	-	-	-	585	0.24	1.7	45	0.18	1.4	-	-	-
	T8430	0.4	225	0.20	1.7	120	0.18	1.7	-	-	-	615	0.24	1.7	45	0.18	1.4	-	-	-
	T9325	0.4	270	0.20	1.7	160	0.18	1.7	-	-	-	-	-	60	0.18	1.4	-	-	-	
CNMG 120408EL-SI	T7325	0.8	215	0.35	1.7	165	0.32	1.7	-	-	-	-	-	65	0.25	1.4	-	-	-	
	T7335	0.8	205	0.35	1.7	155	0.32	1.7	-	-	-	-	-	65	0.25	1.4	-	-	-	
	T8315	0.8	205	0.35	1.7	120	0.32	1.7	-	-	-	615	0.42	1.7	50	0.25	1.4	-	-	-
	T8330	0.8	195	0.35	1.7	115	0.32	1.7	-	-	-	585	0.42	1.7	45	0.25	1.4	-	-	-
	T8430	0.8	210	0.35	1.7	115	0.32	1.7	-	-	-	585	0.42	1.7	45	0.25	1.4	-	-	-
CNMG 120412EL-SI	T8430	1.2	225	0.35	1.7	120	0.32	1.7	-	-	-	615	0.42	1.7	45	0.25	1.4	-	-	-

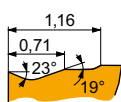

W-F wiper geometri, inceden finişe kadar işleme, yüksek ilerleme hızları ve iyileştirilmiş yüzey finışı için.

CNMG 120408W-F	T9315	0.8	215	0.45	0.8	-	-	-	200	0.45	0.8	-	-	-	-	-	-	-	-
	T9325	0.8	190	0.45	0.8	-	-	-	180	0.45	0.8	-	-	-	-	-	-	-	-

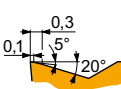

W-M wiper geometri, yarı kabadan kabaya kadar işleme, yüksek ilerleme hızları ve iyileştirilmiş yüzey finışı için.

CNMG 120408W-M	T5315	0.8	230	0.45	1.5	-	-	-	215	0.45	1.5	-	-	-	-	-	-	-	-
	T9315	0.8	200	0.45	1.5	-	-	-	190	0.45	1.5	-	-	-	-	-	-	-	-
	T9325	0.8	185	0.45	1.5	-	-	-	175	0.45	1.5	-	-	-	-	-	-	-	-
CNMG 120412W-M	T5315	1.2	230	0.55	1.5	-	-	-	215	0.55	1.5	-	-	-	-	-	-	-	-
	T9315	1.2	200	0.55	1.5	-	-	-	190	0.55	1.5	-	-	-	-	-	-	-	-
	T9325	1.2	180	0.55	1.5	-	-	-	170	0.55	1.5	-	-	-	-	-	-	-	-

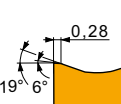

W-MR wiper geometri, finişten kabaya kadar işleme, yüksek ilerleme hızları ve iyileştirilmiş yüzey finışı için.

CNMG 120404W-MR	T9315	0.4	200	0.30	1.5	-	-	-	190	0.30	1.5	-	-	-	-	-	-	-	-
	T9325	0.4	180	0.30	1.5	105	0.27	1.5	170	0.30	1.5	-	-	-	-	-	-	-	-
CNMG 120408W-MR	T5315	0.8	230	0.45	1.5	-	-	-	215	0.45	1.5	-	-	-	-	-	-	-	-
	T9310	0.8	215	0.45	1.5	-	-	-	200	0.45	1.5	-	-	-	-	-	-	-	-
	T9315	0.8	200	0.45	1.5	-	-	-	190	0.45	1.5	-	-	-	-	-	-	-	-
CNMG 120412W-MR	T9325	0.8	185	0.45	1.5	110	0.41	1.5	175	0.45	1.5	-	-	-	-	-	-	-	-
	T5315	1.2	230	0.55	1.5	-	-	-	215	0.55	1.5	-	-	-	-	-	-	-	-
	T9310	1.2	210	0.55	1.5	-	-	-	195	0.55	1.5	-	-	-	-	-	-	-	-
CNMG 120412W-MR	T9315	1.2	200	0.55	1.5	-	-	-	190	0.55	1.5	-	-	-	-	-	-	-	-
	T9325	1.2	180	0.55	1.5	105	0.50	1.5	170	0.55	1.5	-	-	-	-	-	-	-	-

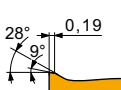

W-NR wiper geometri, finişten kabaya kadar işleme, yüksek ilerleme hızları ve iyileştirilmiş yüzey finışı için.

CNMG 120404W-NM	T7325	0.4	195	0.20	2.1	150	0.18	2.1	-	-	-	-	-	60	0.16	1.7	-	-	-
	T7335	0.4	190	0.20	2.1	145	0.18	2.1	-	-	-	-	-	60	0.16	1.7	-	-	-
	T9315	0.4	270	0.20	2.1	-	-	-	255	0.20	2.1	-	-	-	-	-	-	-	-
	T9325	0.4	240	0.20	2.1	140	0.18	2.1	225	0.20	2.1	-	-	-	50	0.16	1.7	-	-



Kesme hızı (vc), ilerleme (f) ve kesme derinliği (ap) için uygunluk ve başlangıç değerleri. Daha ileri hesaplamalar için İşleme Hesaplayıcısı uygulamasına başvurun.

Product	RE (mm)	P			M			K			N			S			H		
		vc (m/min)	f (mm/rev)	ap (mm)	vc (m/min)	f (mm/rev)	ap (mm)	vc (m/min)	f (mm/rev)	ap (mm)	vc (m/min)	f (mm/rev)	ap (mm)	vc (m/min)	f (mm/rev)	ap (mm)	vc (m/min)	f (mm/rev)	ap (mm)

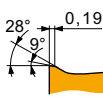

W-NR wiper geometri, finişten kabaya kadar işleme, yüksek ilerleme hızları ve iyileştirilmiş yüzey finiş için.

CNMG 120408W-NM	T7325	0.8	215	0.25	2.1	165	0.23	2.1	-	-	-	-	-	-	65	0.20	1.7	-	-	-
	T7335	0.8	210	0.25	2.1	160	0.23	2.1	-	-	-	-	-	-	65	0.20	1.7	-	-	-
	T9315	0.8	290	0.25	2.1	-	-	-	275	0.25	2.1	-	-	-	-	-	-	-	-	-
	T9325	0.8	260	0.25	2.1	155	0.23	2.1	245	0.25	2.1	-	-	-	55	0.20	1.7	-	-	-
CNMG 120412W-NM	T7325	1.2	215	0.30	2.1	165	0.27	2.1	-	-	-	-	-	-	65	0.24	1.7	-	-	-
	T7335	1.2	210	0.30	2.1	160	0.27	2.1	-	-	-	-	-	-	65	0.24	1.7	-	-	-
	T9315	1.2	285	0.30	2.1	-	-	-	270	0.30	2.1	-	-	-	-	-	-	-	-	-
	T9325	1.2	255	0.30	2.1	150	0.27	2.1	240	0.30	2.1	-	-	-	55	0.24	1.7	-	-	-

CNMM



	IC (mm)	D1 (mm)	L (mm)	S (mm)
1204	12.700	5.16	12.90	4.76
1606	15.875	6.35	16.10	6.35
1906	19.050	7.94	19.30	6.35
2509	25.400	9.12	25.80	9.53

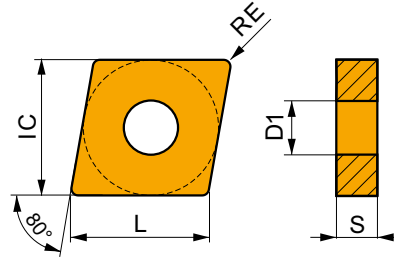

Kesme hızı (vc), ilerleme (f) ve kesme derinliği (ap) için uygunluk ve başlangıç değerleri. Daha ileri hesaplamalar için İşleme Hesaplayıcısı uygulamasına başvurun.

Product	RE (mm)	P			M			K			N			S			H		
		vc (m/min)	f (mm/rev)	ap (mm)	vc (m/min)	f (mm/rev)	ap (mm)	vc (m/min)	f (mm/rev)	ap (mm)	vc (m/min)	f (mm/rev)	ap (mm)	vc (m/min)	f (mm/rev)	ap (mm)	vc (m/min)	f (mm/rev)	ap (mm)

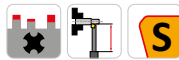
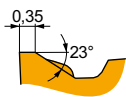

DR geometri, yarı kabadan kaba işleme, ve sürekli aralıklı kesmeye kadar uygun.

CNMM 160612E-DR	T9315	1.2	225	0.45	6.0	-	-	-	210	0.45	6.0	-	-	-	-	-	-	-	-	-
	T9325	1.2	200	0.45	6.0	120	0.41	6.0	190	0.45	6.0	-	-	-	-	-	-	-	-	
	T9335	1.2	170	0.45	6.0	100	0.41	6.0	-	-	-	-	-	-	-	-	-	-	-	
CNMM 190608E-DR	T9315	0.8	215	0.40	8.0	-	-	-	200	0.40	8.0	-	-	-	-	-	-	-	-	
	T9325	0.8	190	0.40	8.0	110	0.36	8.0	180	0.40	8.0	-	-	-	-	-	-	-	-	
CNMM 190612E-DR	T9315	1.2	220	0.45	8.0	-	-	-	205	0.45	8.0	-	-	-	-	-	-	-	-	
	T9325	1.2	195	0.45	8.0	115	0.41	8.0	185	0.45	8.0	-	-	-	-	-	-	-	-	
	T9335	1.2	170	0.45	8.0	100	0.41	8.0	-	-	-	-	-	-	-	-	-	-		
CNMM 190616E-DR	T9325	1.6	195	0.50	9.0	115	0.45	9.0	185	0.50	9.0	-	-	-	-	-	-	-	-	
	T9335	1.6	170	0.50	9.0	100	0.45	9.0	-	-	-	-	-	-	-	-	-	-		

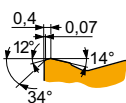

HR geometri, kapadan ağır kaba işleme kadar, darbesizden darbeye kadar uygun.

CNMM 190616E-HR	6640	1.6	75	0.60	10.0	45	0.54	10.0	70	0.60	10.0	-	-	-	-	-	-	-
	T8345	1.6	55	0.60	10.0	30	0.54	10.0	50	0.60	10.0	-	-	-	-	-	-	-
	T9325	1.6	105	0.60	10.0	60	0.54	10.0	95	0.60	10.0	-	-	-	-	-	-	-
	T9335	1.6	80	0.60	10.0	45	0.54	10.0	-	-	-	-	-	-	-	-	-	-
CNMM 190624E-HR	T8345	2.4	60	0.65	10.0	35	0.59	10.0	55	0.65	10.0	-	-	-	-	-	-	-
	T9315	2.4	115	0.65	10.0	-	-	-	105	0.65	10.0	-	-	-	-	-	-	-
	T9325	2.4	100	0.65	10.0	60	0.59	10.0	95	0.65	10.0	-	-	-	-	-	-	-
	T9335	2.4	85	0.65	10.0	50	0.59	10.0	-	-	-	-	-	-	-	-	-	



Kesme hızı (vc), ilerleme (f) ve kesme derinliği (ap) için uygunluk ve başlangıç değerleri. Daha ileri hesaplamalar için İşleme Hesaplayıcısı uygulamasına başvurun.

Product	RE (mm)	P			M			K			N			S			H		
		vc (m/min)	f (mm/rev)	ap (mm)	vc (m/min)	f (mm/rev)	ap (mm)	vc (m/min)	f (mm/rev)	ap (mm)	vc (m/min)	f (mm/rev)	ap (mm)	vc (m/min)	f (mm/rev)	ap (mm)	vc (m/min)	f (mm/rev)	ap (mm)

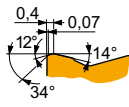

HR geometri, kaptan ağır kaba işlemeye kadar, darbesizden darbeli kesime kadar uygun.

CNMM 250924E-HR	6640	2.4	75	0.65	14.0	45	0.59	14.0	70	0.65	14.0	-	-	-	-	-	-	-
	T8345	2.4	55	0.65	14.0	30	0.59	14.0	50	0.65	14.0	-	-	-	-	-	-	-
	T9315	2.4	110	0.65	14.0	-	-	-	100	0.65	14.0	-	-	-	-	-	-	-
	T9325	2.4	100	0.65	14.0	60	0.59	14.0	95	0.65	14.0	-	-	-	-	-	-	-
	T9335	2.4	80	0.65	14.0	45	0.59	14.0	-	-	-	-	-	-	-	-	-	-

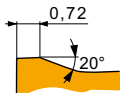

HR2 geometri, kaptan ağır kaba işlemeye kadar, darbesizden darbeli kesime kadar uygun.

CNMM 190616-HR2	T9226	1.6	85	0.65	10.0	50	0.59	10.0	80	0.65	10.0	-	-	-	-	-	-	-
	T9315	1.6	110	0.65	10.0	-	-	-	100	0.65	10.0	-	-	-	-	-	-	-
	T9335	1.6	80	0.65	10.0	45	0.59	10.0	-	-	-	-	-	-	-	-	-	-
CNMM 190624-HR2	T9226	2.4	80	0.85	10.0	45	0.77	10.0	75	0.85	10.0	-	-	-	-	-	-	-
	T9315	2.4	100	0.85	10.0	-	-	-	95	0.85	10.0	-	-	-	-	-	-	-
	T9335	2.4	75	0.85	10.0	45	0.77	10.0	-	-	-	-	-	-	-	-	-	-
CNMM 250924-HR2	T9315	2.4	100	0.85	12.0	-	-	-	95	0.85	12.0	-	-	-	-	-	-	-
	T9335	2.4	75	0.85	12.0	45	0.77	12.0	-	-	-	-	-	-	-	-	-	-

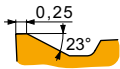

NR geometri, yarı kaptan kaba işlemeye kadar, darbesizden darbeli kesime kadar uygun.

CNMM 120408E-NR	6640	0.8	155	0.40	3.0	90	0.36	3.0	145	0.40	3.0	-	-	-	-	-	-	-	
	T7325	0.8	175	0.40	3.0	135	0.36	3.0	-	-	-	55	0.28	2.4	-	-	-	-	
	T7335	0.8	165	0.40	3.0	125	0.36	3.0	-	-	-	50	0.28	2.4	-	-	-	-	
	T8330	0.8	155	0.40	3.0	90	0.36	3.0	145	0.40	3.0	-	-	-	35	0.28	2.4	-	
	T8430	0.8	165	0.40	3.0	90	0.36	3.0	135	0.40	3.0	-	-	-	35	0.28	2.4	-	
	T9315	0.8	215	0.40	3.0	-	-	-	200	0.40	3.0	-	-	-	-	-	-	-	-
	T9325	0.8	195	0.40	3.0	115	0.36	3.0	185	0.40	3.0	-	-	-	40	0.28	2.4	-	
CNMM 120412E-NR	T7325	1.2	185	0.40	3.0	140	0.36	3.0	-	-	-	60	0.28	2.4	-	-	-	-	
	T7335	1.2	175	0.40	3.0	135	0.36	3.0	-	-	-	55	0.28	2.4	-	-	-	-	
	T8330	1.2	165	0.40	3.0	95	0.36	3.0	155	0.40	3.0	-	-	-	40	0.28	2.4	-	
	T8430	1.2	170	0.40	3.0	90	0.36	3.0	135	0.40	3.0	-	-	-	35	0.28	2.4	-	
	T9325	1.2	205	0.40	3.0	120	0.36	3.0	190	0.40	3.0	-	-	-	45	0.28	2.4	-	

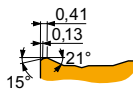

NR2 geometri, yarı kaptan kaba işlemeye kadar, darbesizden darbeli kesime kadar uygun.

CNMM 120408E-NR2	T7325	0.8	165	0.40	5.0	125	0.36	5.0	-	-	-	50	0.28	4.0	-	-	-	-
	T7335	0.8	155	0.40	5.0	120	0.36	5.0	-	-	-	50	0.28	4.0	-	-	-	-
	T8330	0.8	150	0.40	5.0	90	0.36	5.0	140	0.40	5.0	-	-	-	35	0.28	4.0	-
	T8430	0.8	150	0.40	5.0	80	0.36	5.0	125	0.40	5.0	-	-	-	30	0.28	4.0	-
	T9315	0.8	205	0.40	5.0	-	-	-	190	0.40	5.0	-	-	-	-	-	-	-
CNMM 120412E-NR2	T9325	0.8	185	0.40	5.0	110	0.36	5.0	175	0.40	5.0	-	-	-	40	0.28	4.0	-
	T7335	1.2	155	0.45	5.0	120	0.41	5.0	-	-	-	50	0.32	4.0	-	-	-	-
	T8330	1.2	150	0.45	5.0	90	0.41	5.0	140	0.45	5.0	-	-	-	35	0.32	4.0	-
	T8430	1.2	150	0.45	5.0	80	0.41	5.0	125	0.45	5.0	-	-	-	30	0.32	4.0	-
	T9315	1.2	205	0.45	5.0	-	-	-	190	0.45	5.0	-	-	-	-	-	-	-
CNMM 160608E-NR2	T9325	1.2	185	0.45	5.0	110	0.41	5.0	175	0.45	5.0	-	-	-	40	0.32	4.0	-
	T8330	0.8	145	0.40	6.0	85	0.36	6.0	135	0.40	6.0	-	-	-	35	0.32	4.8	-
	T8430	0.8	150	0.40	6.0	80	0.36	6.0	125	0.40	6.0	-	-	-	30	0.32	4.8	-
T9325	0.8	180	0.40	6.0	105	0.36	6.0	170	0.40	6.0	-	-	-	40	0.32	4.8	-	



Kesme hızı (vc), ilerleme (f) ve kesme derinliği (ap) için uygunluk ve başlangıç değerleri. Daha ileri hesaplamalar için İşleme Hesaplayıcısı uygulamasına başvurun.

Product	RE  (mm)	P			M			K			N			S			H		
		vc (m/min)	f (mm/rev)	ap (mm)	vc (m/min)	f (mm/rev)	ap (mm)	vc (m/min)	f (mm/rev)	ap (mm)	vc (m/min)	f (mm/rev)	ap (mm)	vc (m/min)	f (mm/rev)	ap (mm)	vc (m/min)	f (mm/rev)	ap (mm)

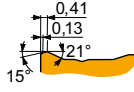

NR2 geometri, yarı kabadan kaba işleme kadar, darbesizden darbeli kesime kadar uygun.

CNMM 160612E-NR2	T7325	1.2	165	0.45	6.0	125	0.41	6.0	-	-	-	50	0.36	4.8	-	-	-
	T7335	1.2	155	0.45	6.0	120	0.41	6.0	-	-	-	50	0.36	4.8	-	-	-
	T8330	1.2	145	0.45	6.0	85	0.41	6.0	135	0.45	6.0	35	0.36	4.8	-	-	-
	T8430	1.2	150	0.45	6.0	80	0.41	6.0	125	0.45	6.0	30	0.36	4.8	-	-	-
	T9315	1.2	205	0.45	6.0	-	-	-	190	0.45	6.0	-	-	-	-	-	-
	T9325	1.2	185	0.45	6.0	110	0.41	6.0	175	0.45	6.0	40	0.36	4.8	-	-	-
CNMM 160616E-NR2	T7325	1.6	165	0.50	6.0	125	0.45	6.0	-	-	-	50	0.40	4.8	-	-	-
	T7335	1.6	160	0.50	6.0	120	0.45	6.0	-	-	-	50	0.40	4.8	-	-	-
	T9325	1.6	180	0.50	6.0	105	0.45	6.0	170	0.50	6.0	40	0.40	4.8	-	-	-
CNMM 190612E-NR2	T7325	1.2	155	0.45	9.0	120	0.41	9.0	-	-	-	50	0.36	7.2	-	-	-
	T7335	1.2	145	0.45	9.0	110	0.41	9.0	-	-	-	45	0.36	7.2	-	-	-
	T8330	1.2	140	0.45	9.0	80	0.41	9.0	130	0.45	9.0	35	0.36	7.2	-	-	-
	T8430	1.2	140	0.45	9.0	75	0.41	9.0	115	0.45	9.0	30	0.36	7.2	-	-	-
	T9325	1.2	175	0.45	9.0	105	0.41	9.0	165	0.45	9.0	35	0.36	7.2	-	-	-
CNMM 190616E-NR2	T7325	1.6	160	0.50	9.0	120	0.45	9.0	-	-	-	50	0.40	7.2	-	-	-
	T7335	1.6	150	0.50	9.0	115	0.45	9.0	-	-	-	45	0.40	7.2	-	-	-
	T8330	1.6	140	0.50	9.0	80	0.45	9.0	130	0.50	9.0	35	0.40	7.2	-	-	-
	T8430	1.6	140	0.50	9.0	75	0.45	9.0	115	0.50	9.0	30	0.40	7.2	-	-	-
	T9315	1.6	195	0.50	9.0	-	-	-	185	0.50	9.0	-	-	-	-	-	-
	T9325	1.6	175	0.50	9.0	105	0.45	9.0	165	0.50	9.0	35	0.40	7.2	-	-	-
CNMM 190624E-NR2	T7335	2.4	130	0.80	9.0	100	0.72	9.0	-	-	-	40	0.56	7.2	-	-	-
	T9325	2.4	150	0.80	9.0	90	0.72	9.0	140	0.80	9.0	30	0.56	7.2	-	-	-
	T9325	2.4	150	0.80	9.0	90	0.72	9.0	140	0.80	9.0	30	0.56	7.2	-	-	-
CNMM 250924E-NR2	T7325	2.4	100	0.80	12.0	75	0.72	12.0	-	-	-	30	0.56	9.6	-	-	-
	T7335	2.4	95	0.80	12.0	70	0.72	12.0	-	-	-	30	0.56	9.6	-	-	-
	T8430	2.4	80	0.80	12.0	45	0.72	12.0	65	0.80	12.0	15	0.56	9.6	-	-	-
	T9315	2.4	110	0.80	12.0	-	-	-	100	0.80	12.0	-	-	-	-	-	-
	T9325	2.4	100	0.80	12.0	60	0.72	12.0	95	0.80	12.0	20	0.56	9.6	-	-	-

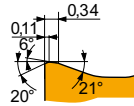

NRM geometri, orta kabadan kabaya kadar işlemek için pozitif tasarım, darbesizden darbeli kesime kadar uygun.

CNMM 250924-NRM	T7325	2.4	95	0.70	10.0	70	0.63	10.0	-	-	-	30	0.49	8.0	-	-	-
	T7335	2.4	90	0.70	10.0	70	0.63	10.0	-	-	-	25	0.49	8.0	-	-	-
	T9315	2.4	115	0.70	10.0	-	-	-	105	0.70	10.0	-	-	-	-	-	-

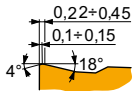

OR geometri, orta kabadan kabaya kadar işlemek için, darbesizden darbeli kesime kadar uygun.

CNMM 120408E-OR	T8330	0.8	150	0.40	5.0	90	0.36	5.0	140	0.40	5.0	35	0.28	4.0	-	-	-
	T8430	0.8	150	0.40	5.0	80	0.36	5.0	125	0.40	5.0	30	0.28	4.0	-	-	-
	T9315	0.8	205	0.40	5.0	-	-	-	190	0.40	5.0	-	-	-	-	-	-
	T9325	0.8	185	0.40	5.0	110	0.36	5.0	175	0.40	5.0	40	0.28	4.0	-	-	-
	T9335	0.8	160	0.40	5.0	95	0.36	5.0	-	-	-	35	0.28	4.0	-	-	-
CNMM 120412E-OR	T9315	1.2	205	0.45	5.0	-	-	-	190	0.45	5.0	-	-	-	-	-	-
	T9325	1.2	185	0.45	5.0	110	0.41	5.0	175	0.45	5.0	40	0.36	4.0	-	-	-
	T9335	1.2	165	0.45	5.0	95	0.41	5.0	-	-	-	35	0.36	4.0	-	-	-
CNMM 120416E-OR	T9325	1.6	190	0.50	5.0	110	0.45	5.0	180	0.50	5.0	40	0.40	4.0	-	-	-
	T9335	1.6	165	0.50	5.0	95	0.45	5.0	-	-	-	35	0.40	4.0	-	-	-
CNMM 160608E-OR	T9315	0.8	205	0.40	6.0	-	-	-	190	0.40	6.0	-	-	-	-	-	-
	T9325	0.8	180	0.40	6.0	105	0.36	6.0	170	0.40	6.0	40	0.32	4.8	-	-	-
	T9335	0.8	160	0.40	6.0	95	0.36	6.0	-	-	-	35	0.32	4.8	-	-	-
CNMM 160612E-OR	T8430	1.2	150	0.45	6.0	80	0.41	6.0	125	0.45	6.0	30	0.36	4.8	-	-	-
	T9315	1.2	205	0.45	6.0	-	-	-	190	0.45	6.0	-	-	-	-	-	-
	T9325	1.2	185	0.45	6.0	110	0.41	6.0	175	0.45	6.0	40	0.36	4.8	-	-	-



Kesme hızı (vc), ilerleme (f) ve kesme derinliği (ap) için uygunluk ve başlangıç değerleri. Daha ileri hesaplamalar için İşleme Hesaplayıcısı uygulamasına başvurun.

Product	RE (mm)	P			M			K			N			S			H		
		vc (m/min)	f (mm/rev)	ap (mm)	vc (m/min)	f (mm/rev)	ap (mm)	vc (m/min)	f (mm/rev)	ap (mm)	vc (m/min)	f (mm/rev)	ap (mm)	vc (m/min)	f (mm/rev)	ap (mm)	vc (m/min)	f (mm/rev)	ap (mm)

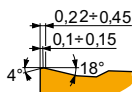

OR geometri, orta kabadan kabaya kadar işlemek için, darbesizden darbeli kesime kadar uygun.

CNMM 160616E-OR	T9315	1.6	205	0.50	6.0	–	–	–	190	0.50	6.0	–	–	–	–	–	–	–	–
	T9325	1.6	180	0.50	6.0	105	0.45	6.0	170	0.50	6.0	–	–	–	40	0.40	4.8	–	–
CNMM 190612E-OR	T8330	1.2	140	0.45	9.0	80	0.41	9.0	130	0.45	9.0	–	–	–	35	0.36	7.2	–	–
	T8430	1.2	140	0.45	9.0	75	0.41	9.0	115	0.45	9.0	–	–	–	30	0.36	7.2	–	–
	T9315	1.2	195	0.45	9.0	–	–	–	185	0.45	9.0	–	–	–	–	–	–	–	–
CNMM 190616E-OR	T9325	1.2	175	0.45	9.0	105	0.41	9.0	165	0.45	9.0	–	–	–	35	0.36	7.2	–	–
	T9335	1.2	150	0.45	9.0	90	0.41	9.0	–	–	–	–	–	–	30	0.36	7.2	–	–
	T8330	1.6	140	0.50	9.0	80	0.45	9.0	130	0.50	9.0	–	–	–	35	0.40	7.2	–	–
	T8345	1.6	120	0.50	9.0	70	0.45	9.0	110	0.50	9.0	–	–	–	30	0.40	7.2	–	–
	T8430	1.6	140	0.50	9.0	75	0.45	9.0	115	0.50	9.0	–	–	–	30	0.40	7.2	–	–
CNMM 190624E-OR	T9315	1.6	195	0.50	9.0	–	–	–	185	0.50	9.0	–	–	–	–	–	–	–	–
	T9325	1.6	175	0.50	9.0	105	0.45	9.0	165	0.50	9.0	–	–	–	35	0.40	7.2	–	–
	T9335	1.6	155	0.50	9.0	90	0.45	9.0	–	–	–	–	–	–	30	0.40	7.2	–	–
	T9315	2.4	165	0.80	9.0	–	–	–	155	0.80	9.0	–	–	–	–	–	–	–	–
CNMM 250924E-OR	T9325	2.4	150	0.80	9.0	90	0.72	9.0	140	0.80	9.0	–	–	–	30	0.56	7.2	–	–
	T8330	2.4	75	1.00	12.0	45	0.90	12.0	70	1.00	12.0	–	–	–	15	0.70	9.6	–	–
	T8430	2.4	75	1.00	12.0	40	0.90	12.0	60	1.00	12.0	–	–	–	15	0.70	9.6	–	–
	T9315	2.4	100	1.00	12.0	–	–	–	95	1.00	12.0	–	–	–	–	–	–	–	–
	T9325	2.4	95	1.00	12.0	55	0.90	12.0	90	1.00	12.0	–	–	–	20	0.70	9.6	–	–
	T9335	2.4	75	1.00	12.0	45	0.90	12.0	–	–	–	–	–	–	15	0.70	9.6	–	–

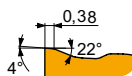

OR geometri, orta kabadan ağır kabaya kadar işlemek için, darbesizden darbeli kesime kadar uygun.

CNMM 190616E-OR1	T9325	1.6	175	0.50	9.0	105	0.45	9.0	165	0.50	9.0	–	–	–	35	0.35	7.2	–	–
	T9335	1.6	155	0.50	9.0	90	0.45	9.0	–	–	–	–	–	–	30	0.35	7.2	–	–

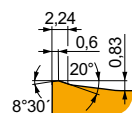

Geometri 923, yarı kabadan ağır kaba işlemeye kadar ve darbesizden ağır darbeli kesime kadar uygun.

CNMM 250924S-923	T8330	2.4	75	0.85	12.0	45	0.77	12.0	70	0.85	12.0	–	–	–	15	0.60	9.6	–	–
	T8430	2.4	75	0.85	12.0	40	0.77	12.0	60	0.85	12.0	–	–	–	15	0.60	9.6	–	–
	T9335	2.4	75	0.85	12.0	45	0.77	12.0	–	–	–	–	–	–	15	0.60	9.6	–	–



CNGA CER

	IC	D1	L	S
	(mm)	(mm)	(mm)	(mm)
1204	12.700	5.16	12.90	4.76

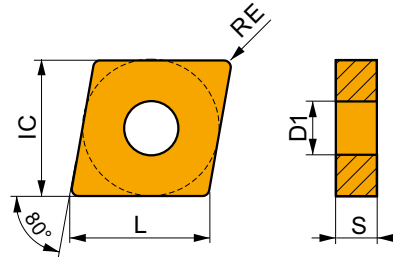

Kesme hızı (vc), ilerleme (f) ve kesme derinliği (ap) için uygunluk ve başlangıç değerleri. Daha ileri hesaplamalar için İşleme Hesaplayıcısı uygulamasına başvurun.

Product	RE	P			M			K			N			S			H		
		vc	f	ap	vc	f	ap	vc	f	ap	vc	f	ap	vc	f	ap	vc	f	ap
	(mm)	(m/min)	(mm/rev)	(mm)	(m/min)	(mm/rev)	(mm)	(m/min)	(mm/rev)	(mm)	(m/min)	(mm/rev)	(mm)	(m/min)	(mm/rev)	(mm)	(m/min)	(mm/rev)	(mm)

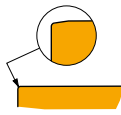
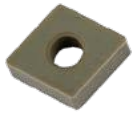

Yüksek hızlı işleme ve darbesiz kesme için.

CNGA 120404 T02020	TC100	0.4	-	-	-	-	-	-	590	0.10	2.0	-	-	-	-	-	-	-	-
CNGA 120408 T01020	TC100	0.8	-	-	-	-	-	-	550	0.20	2.0	-	-	-	-	-	-	-	-
CNGA 120412 T01020	TC100	1.2	-	-	-	-	-	-	540	0.25	2.0	-	-	-	-	-	-	-	-

CNGN CER

	IC	L	S
	(mm)	(mm)	(mm)
1204	12.700	12.90	4.76
1207	12.700	12.90	7.94

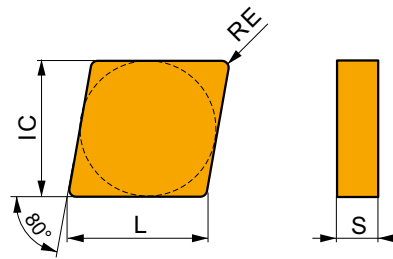

Kesme hızı (vc), ilerleme (f) ve kesme derinliği (ap) için uygunluk ve başlangıç değerleri. Daha ileri hesaplamalar için İşleme Hesaplayıcısı uygulamasına başvurun.

Product	RE	P			M			K			N			S			H		
		vc	f	ap	vc	f	ap	vc	f	ap	vc	f	ap	vc	f	ap	vc	f	ap
	(mm)	(m/min)	(mm/rev)	(mm)	(m/min)	(mm/rev)	(mm)	(m/min)	(mm/rev)	(mm)	(m/min)	(mm/rev)	(mm)	(m/min)	(mm/rev)	(mm)	(m/min)	(mm/rev)	(mm)

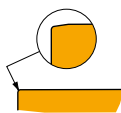

Yüksek hızlı işleme ve darbesiz kesme için.

CNGN 120408 T01020	TC100	0.8	-	-	-	-	-	-	550	0.20	2.0	-	-	-	-	-	-	-	-
CNGN 120708 T01020	TC100	0.8	-	-	-	-	-	-	550	0.20	2.0	-	-	-	-	-	-	-	-
CNGN 120712 T01020	TC100	1.2	-	-	-	-	-	-	540	0.25	2.0	-	-	-	-	-	-	-	-



DCBN(RL) EXT

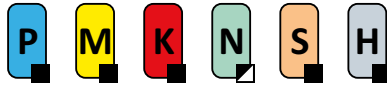

PRAMET

D



CN.. Uç için Çift Sıklımlı 75° Dış Kateri

Çift sıklımlı 75° Sağ/Sol dış kater. Negatif CN.. 12 - 19 uçlarla çap, alın ve pah tornalama için uygundur. 20x20 - 40x40mm shaft ölçüleri. Gövde uzun takım ömrü için işlem görmüştür.

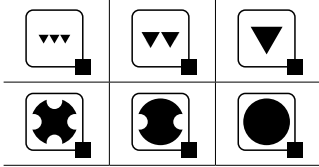
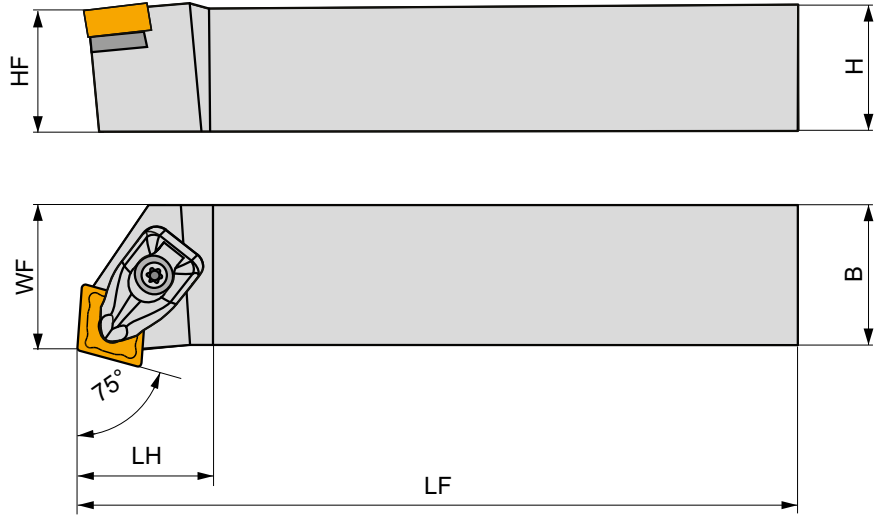

Product	H	B	HF	WF	LF	LH	LAMS	GAMO	kg	GI	DC	AT
	(mm)	(mm)	(mm)	(mm)	(mm)	(mm)	(°)	(°)				
R DCBNR 2020 K 12	20	20	20	17	125	34.2	-6	-6	0.43	GI043	DC12	AT001
DCBNR 2525 M 12	25	25	25	22	150	34.6	-6	-6	0.76	GI043	DC12	AT001
DCBNR 3225 P 12	32	25	32	22	170	34.6	-6	-6	1.09	GI043	DC12	AT001
DCBNR 2525 M 16	25	25	25	22	150	41.5	-6	-6	0.80	GI050	DC16	AT005
DCBNR 3225 P 16	32	25	32	22	170	32	-6	-6	1.11	GI050	DC16	AT005
DCBNR 3232 P 19	32	32	32	27	170	46.1	-6	-6	1.39	GI042	DC19	-
DCBNR 4040 S 19	40	40	40	35	250	46.7	-6	-6	3.16	GI042	DC19	-
L DCBNL 2020 K 12	20	20	20	17	125	34.2	-6	-6	0.43	GI043	DC12	AT001
DCBNL 2525 M 12	25	25	25	22	150	34.6	-6	-6	0.76	GI043	DC12	AT001
DCBNL 3225 P 12	32	25	32	22	170	34.6	-6	-6	1.09	GI043	DC12	AT001
DCBNL 2525 M 16	25	25	25	22	150	41.5	-6	-6	0.79	GI050	DC16	AT005
DCBNL 3225 P 16	32	25	32	22	170	32	-6	-6	1.11	GI050	DC16	AT005
DCBNL 3232 P 19	32	32	32	27	170	46.1	-6	-6	1.39	GI042	DC19	-







GI042
GI043
GI050

CN.. 1906..
CN.. 1204..
CN.. 1606..



DC	DCS	Nm	DCS	US	FLAG	
DC12	DCS 12	3.9	DCS 234-01	US 2002-T15P	FLAG T15P/3,5	-
DC16	DCS 16	6.4	DCS 234-03	US 2007-T20P	-	LK T20P
DC19	DCS 19	6.4	DCS 236-01	US 2007-T20P	-	LK T20P



			
AT001a	CN.. 1207..	–	DCS 234-02
AT005a	CN.. 1607..	–	DCS 234-04
AT001b	CER CN.N 1204..	DCS 12C4	–
AT001c	CER CN.A 1204..	DCS 12C2	–
AT005b	CER CN.N 1606..	DCS 16C4	–
AT005c	CER CN.A 1606..	DCS 16C2	–



DCKN(RL) EXT

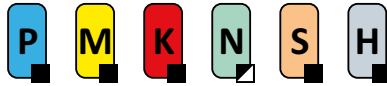

PRAMET

D



CN.. Uç için Çift Sıkmalı 75° (Alın) Dış Kateri

Çift sıkmalı 75° Sağ/Sol dış kater. Negatif CN.. 12 veya 16 uçlarla alın ve pah tornalama için uygundur. 20x20 - 32x32mm şaft ölçüleri. Gövde uzun takım ömrü için işlem görmüştür.

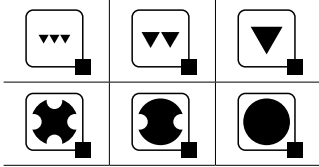
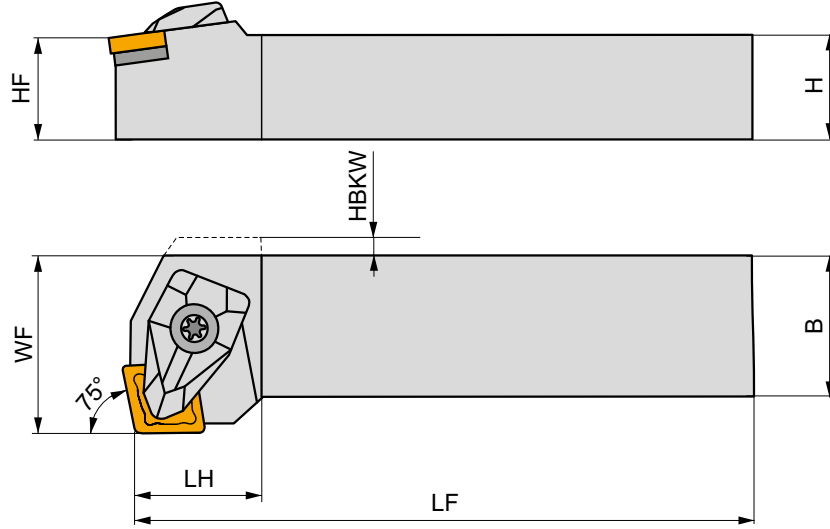
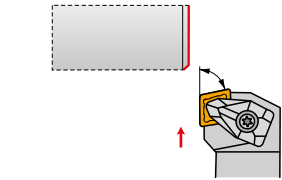

Product	H	B	HF	WF	LF	LH	HBKW	LAMS	GAMO	kg			
	(mm)	(mm)	(mm)	(mm)	(mm)	(mm)	(mm)	(°)	(°)				
R DCKNR 2020 K 12	20	20	20	25	125	21.2	4.5	-6	-6	0.46	GI043	DC12	AT001
DCKNR 2525 M 12	25	25	25	32	150	21.1	-	-6	-6	0.80	GI043	DC12	AT001
DCKNR 3225 P 12	32	25	32	32	170	21.1	-	-6	-6	1.14	GI043	DC12	AT001
DCKNR 3232 P 16	32	32	32	40	170	26	-	-6	-6	1.46	GI050	DC16	AT005
L DCKNL 2020 K 12	20	20	20	25	125	21.2	4.5	-6	-6	0.46	GI043	DC12	AT001
DCKNL 2525 M 12	25	25	25	32	150	21.1	-	-6	-6	0.80	GI043	DC12	AT001
DCKNL 3225 P 12	32	25	32	32	170	21.1	-	-6	-6	1.13	GI043	DC12	AT001
DCKNL 3232 P 16	32	32	32	40	170	26	-	-6	-6	1.46	GI050	DC16	AT005

GI043	GI050	CN.. 1204..	CN.. 1606..

DC12	DCS 12	3.9	DCS 234-01	US 2002-T15P	FLAG T15P/3,5	-
DC16	DCS 16	6.4	DCS 234-03	US 2007-T20P	-	LK T20P

AT001a	CN.. 1207..	-	DCS 234-02
AT005a	CN.. 1607..	-	DCS 234-04
AT001b	CER CN.N 1204..	DCS 12C4	-
AT001c	CER CN.A 1204..	DCS 12C2	-
AT005b	CER CN.N 1606..	DCS 16C4	-
AT005c	CER CN.A 1606..	DCS 16C2	-



DCLN(RL) EXT



PRAMET

D

CN.. Uç için Çift Sıkmalı 95° Dış Kateri

Çift sıkmalı 95° Sağ/Sol dış kater. Negatif CN.. 09 - 19 uçlarla çap, alın ve pah tornalama için uygundur. 16x16 - 40x40mm shaft ölçüleri. Gövde uzun takım ömrü için işlem görmüştür.

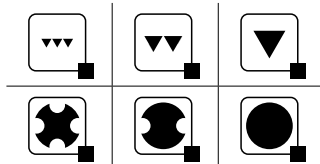
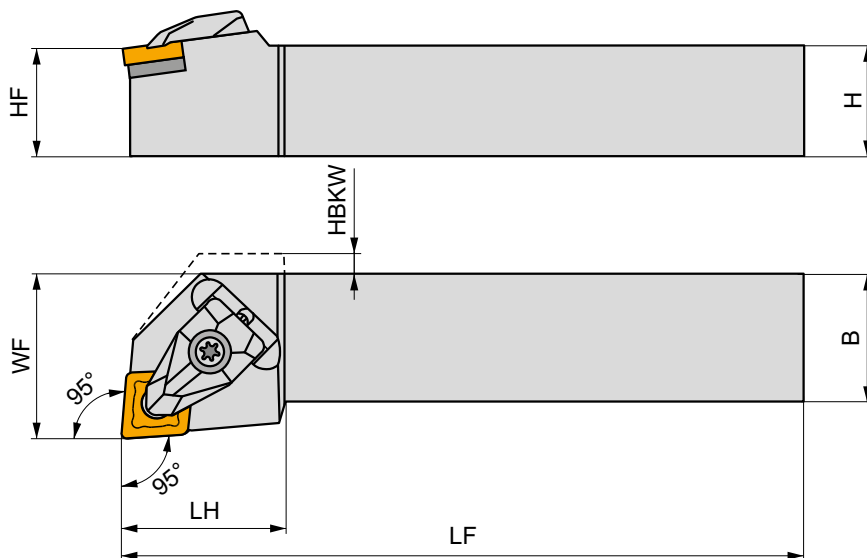
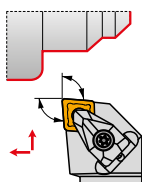



Product	H	B	HF	WF	LF	LH	HBKW	LAMS	GAMO	kg	G1042	G1043	DC09	AT001	
	(mm)	(mm)	(mm)	(mm)	(mm)	(mm)	(mm)	(°)	(°)						
R	DCLNR 1616 H 09	16	16	16	20	100	25	-	-6	0.27	G1133	DC09	-	-	
	DCLNR 2020 K 09	20	20	20	25	125	25	-	-6	0.44	G1133	DC09	-	-	
	DCLNR 2525 M 09	25	25	25	32	150	25	-	-6	0.78	G1133	DC09	-	-	
	DCLNR 1616 H 12	16	16	16	20	100	32.3	4.5	-6	-6	0.26	G1043	DC12	AT001	-
	DCLNR 2020 K 12	20	20	20	25	125	30	-	-6	-6	0.44	G1043	DC12	AT001	-
	DCLNR 2525 M 12	25	25	25	32	150	30	-	-6	-6	0.78	G1043	DC12	AT001	-
	DCLNR 3225 P 12	32	25	32	32	170	30	-	-6	-6	1.10	G1043	DC12	AT001	-
	DCLNR 2525 M 16	25	25	25	32	150	39	-	-6	-6	0.81	G1050	DC16	AT005	-
	DCLNR 3225 P 16	32	25	32	32	170	35	-	-6	-6	1.20	G1050	DC16	AT005	-
	DCLNR 3232 P 19	32	32	32	40	170	40	-	-6	-6	1.55	G1042	DC19	-	-
DCLNR 4040 S 19	40	40	40	50	250	43.4	-	-6	-6	3.26	G1042	DC19	-	-	
L	DCLNL 1616 H 09	16	16	16	20	100	24.8	-	-6	0.22	G1133	DC09	-	-	
	DCLNL 2020 K 09	20	20	20	25	125	24.8	-	-6	0.42	G1133	DC09	-	-	
	DCLNL 2525 M 09	25	25	25	32	150	24.8	-	-6	0.76	G1133	DC09	-	-	
	DCLNL 1616 H 12	16	16	16	20	100	32.2	4.5	-6	-6	0.26	G1043	DC12	AT001	-
	DCLNL 2020 K 12	20	20	20	25	125	32	-	-6	-6	0.44	G1043	DC12	AT001	-
	DCLNL 2525 M 12	25	25	25	32	150	32	-	-6	-6	0.78	G1043	DC12	AT001	-
	DCLNL 3225 P 12	32	25	32	32	170	32	-	-6	-6	1.10	G1043	DC12	AT001	-
	DCLNL 2525 M 16	25	25	25	32	150	39	-	-6	-6	0.81	G1050	DC16	AT005	-
	DCLNL 3225 P 16	32	25	32	32	170	39	-	-6	-6	1.20	G1050	DC16	AT005	-
	DCLNL 3232 P 19	32	32	32	40	170	43.2	-	-6	-6	1.51	G1042	DC19	-	-
DCLNL 4040 S 19	40	40	40	50	250	43.4	-	-6	-6	3.26	G1042	DC19	-	-	













G1042
G1043

CN.. 1906..
CN.. 1204..



	
GI050	CN.. 1606..
GI133	CN.. 0903..

		 Nm				
DC09	DCS 09	1.7	DCS 236-04	US 2004-T09P	FLAG T09P	–
DC12	DCS 12	3.9	DCS 234-01	US 2002-T15P	FLAG T15P/3,5	–
DC16	DCS 16	6.4	DCS 234-03	US 2007-T20P	–	LK T20P
DC19	DCS 19	6.4	DCS 236-01	US 2007-T20P	–	LK T20P
DC112	DCS 12	3.9	DCS 236-03	US 2002-T15P	FLAG T15P/3,5	–

			
AT001a	CN.. 1207..	–	DCS 234-02
AT005a	CN.. 1607..	–	DCS 234-04
AT001b	CER CN.N 1204..	DCS 12C4	–
AT001c	CER CN.A 1204..	DCS 12C2	–
AT005b	CER CN.N 1606..	DCS 16C4	–
AT005c	CER CN.A 1606..	DCS 16C2	–



PCBN(RL) EXT

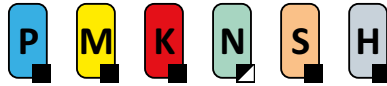

PRAMET

P



CN.. Uç için Levveli 75° Açılı Dış Kater

Levveli, 75° açılı Sağ/Sol dış kater. Negatif CN.. 12, 16 veya 19 uçlarla çap, alın, konik ve pah tornalamak için uygundur. 20x20'den 50x50'ye kadar mevcuttur. Gövde uzun takım ömrü için işlem görmüştür.

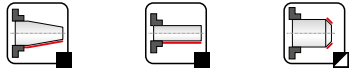
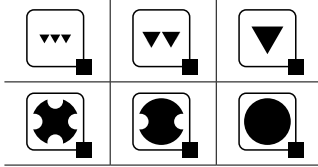
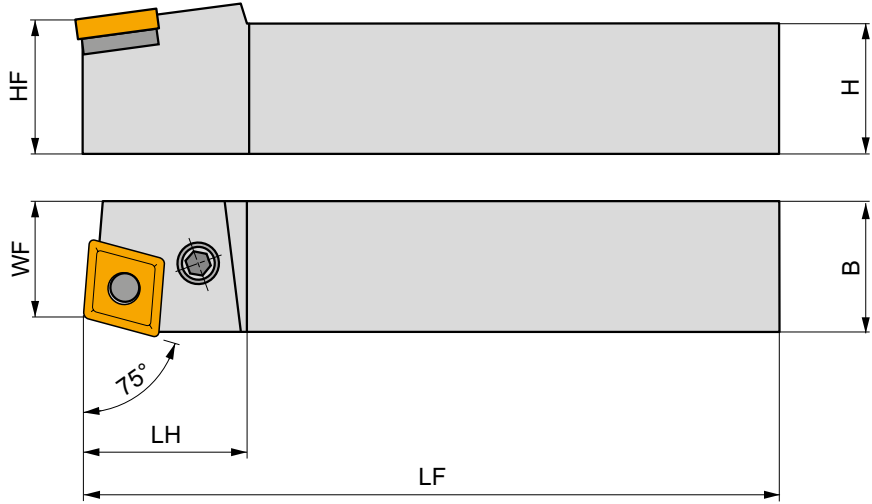
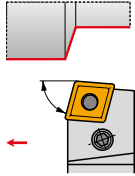

Product	H	B	HF	WF	LF	LH	LAMS	GAMO	kg	G1043	G1050	
	(mm)	(mm)	(mm)	(mm)	(mm)	(mm)	(°)	(°)				
R	PCBNR 2020 K 12	20	20	20	17	125	36	-6	-6	0.43	G1043	PC22
	PCBNR 2525 M 12	25	25	25	22	150	36	-6	-6	0.63	G1043	PC20
	PCBNR 3225 P 12	32	25	32	22	170	36	-6	-6	0.70	G1043	PC20
	PCBNR 3232 P 16	32	32	32	27	170	40	-6	-6	1.36	G1050	PC40
	PCBNR 3232 P 19	32	32	32	27	170	45	-6	-6	1.10	G1042	PC50
	PCBNR 4040 S 19	40	40	40	35	250	45	-6	-6	3.15	G1042	PC50
	PCBNR 4040 S 25	40	40	40	35	250	45	-6	-6	3.10	G1062	PC60
	PCBNR 5050 T 25	50	50	50	43	300	50	-6	-6	5.80	G1062	PC60
L	PCBNL 2020 K 12	20	20	20	17	125	36	-6	-6	0.38	G1043	PC22
	PCBNL 2525 M 12	25	25	25	22	150	36	-6	-6	0.73	G1043	PC20
	PCBNL 3225 P 12	32	25	32	22	170	36	-6	-6	0.70	G1043	PC20
	PCBNL 3232 P 16	32	32	32	27	170	40	-6	-6	1.25	G1050	PC40
	PCBNL 3232 P 19	32	32	32	27	170	45	-6	-6	1.10	G1042	PC50
	PCBNL 4040 S 19	40	40	40	35	250	45	-6	-6	3.15	G1042	PC50
	PCBNL 4040 S 25	40	40	40	35	250	45	-6	-6	3.15	G1062	PC60
	PCBNL 5050 T 25	50	50	50	43	300	50	-6	-6	5.80	G1062	PC60



G1042
G1043
G1050
G1062

CN.. 1906..
CN.. 1204..
CN.. 1606..
CN.. 2509..



PC20
PC22
PC40
PC50
PC60

CNU 120312
CNU 120312
CNU 150312
CNU 190416
CNU 250620

PU 02
PU 02
PU 04
PU 05
PU 06

US 35
US 42
US 36
US 38
US 39

6.0
6.0
6.0
8.0
8.0

M 8x1
M 8x1
M 8x1
M 10x1
M 10x1

22.5
21
26
29
33

NT 05
NT 05
NT 07
NT 06
NT 08

MT 05
MT 05
MT 07
MT 06
MT 08

HXK 4
HXK 4
HXK 4
HXK 5
HXK 5



PCKN(RL) EXT



PRAMET

P



CN.. Uç için Levye 75° Açılı (Alın) Dış Kateri

Levyeli, 75° açılı Sağ/Sol dış kater. Negatif CN.. 12, 16 veya 19 uçlarla alın ve pah tornalamak için uygundur. 20x20'den 32x25'e kadar mevcuttur. Gövde uzun takım ömrü için işlem görmüştür.

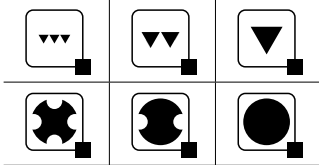
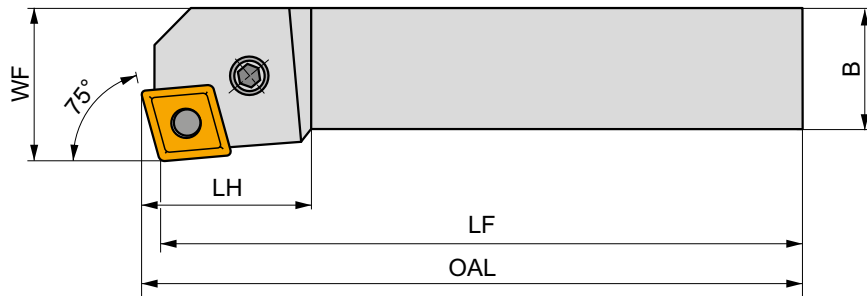
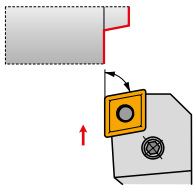

Product	H	B	HF	WF	LF	LH	LAMS	GAMO	kg	G1043	PC22	
	(mm)	(mm)	(mm)	(mm)	(mm)	(mm)	(°)	(°)				
R	PCKNR 2020 K 12	20	20	20	25	125	36	-6	-6	0.42	G1043	PC22
	PCKNR 2525 M 12	25	25	25	32	150	36	-6	-6	0.79	G1043	PC20
	PCKNR 3225 P 12	32	25	32	32	170	36	-6	-6	0.85	G1043	PC20
	PCKNR 3232 P 16	32	32	32	40	170	40	-6	-6	1.43	G1050	PC40
	PCKNR 3232 P 19	32	32	32	40	170	45	-6	-6	1.40	G1042	PC50
	PCKNR 4040 S 19	40	40	40	50	250	45	-6	-6	3.25	G1042	PC50
L	PCKNL 2020 K 12	20	20	20	25	125	36	-6	-6	0.42	G1043	PC22
	PCKNL 2525 M 12	25	25	25	32	150	36	-6	-6	0.78	G1043	PC20
	PCKNL 3225 P 12	32	25	32	32	170	36	-6	-6	1.15	G1043	PC20
	PCKNL 3232 P 16	32	32	32	40	170	40	-6	-6	1.40	G1050	PC40
	PCKNL 3232 P 19	32	32	32	40	170	45	-6	-6	1.40	G1042	PC50
	PCKNL 4040 S 19	40	40	40	50	250	45	-6	-6	3.27	G1042	PC50



G1042
G1043
G1050

CN.. 1906..
CN.. 1204..
CN.. 1606..



PC20
PC22
PC40
PC50

CNU 120312
CNU 120312
CNU 150312
CNU 190416

PU 02
PU 02
PU 04
PU 05

US 35
US 42
US 36
US 38

6.0
6.0
6.0
8.0

M 8x1
M 8x1
M 8x1
M 10x1

22.5
21
26
29

NT 05
NT 05
NT 07
NT 06

MT 05
MT 05
MT 07
MT 06

HXK 4
HXK 4
HXK 4
HXK 5

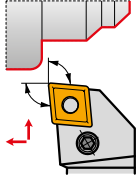

PCLN(RL) EXT

CN.. Uç için Levye 95° Açılı Dış Kater

Levyeli, 95° açılı Sağ/Sol dış kater. Negatif CN.. 12, 16, 19 veya 25 uçlarla çap, alın, konik ve pah tornalamak için uygundur. 20x20'den 50x50'ye kadar mevcuttur. Gövde uzun takım ömrü için işlem görmüştür.



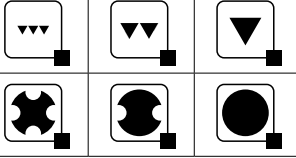
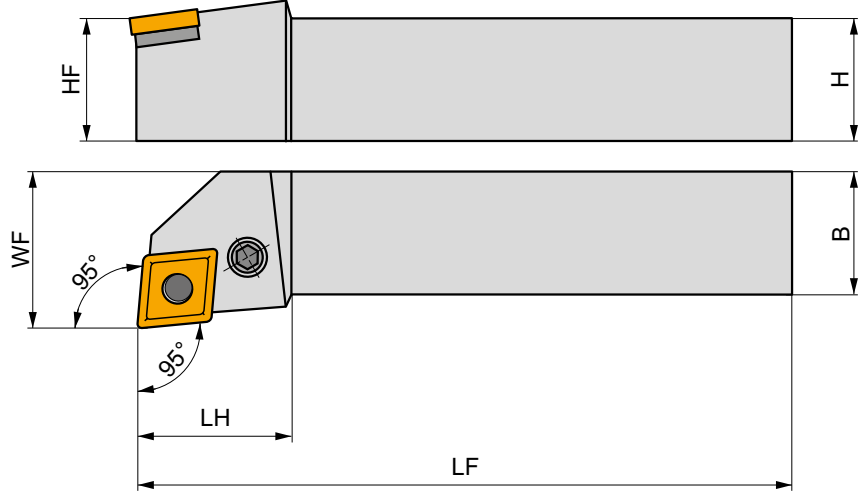









	Product	H	B	HF	WF	LF	LH	LAMS	GAMO	kg	GI043	PC22
		(mm)	(mm)	(mm)	(mm)	(mm)	(mm)	(°)	(°)			
R	PCLNR 2020 K 12	20	20	20	25	125	36	-6	-6	0.44	GI043	PC22
	PCLNR 2525 M 12	25	25	25	32	150	36	-6	-6	0.68	GI043	PC20
	PCLNR 3225 P 12	32	25	32	32	170	36	-6	-6	0.98	GI043	PC20
	PCLNR 3225 P 16	32	25	32	32	170	40	-6	-6	1.10	GI050	PC40
	PCLNR 3232 P 19	32	32	32	40	170	45	-6	-6	1.40	GI042	PC50
	PCLNR 4040 R 19	40	40	40	50	200	45	-6	-6	2.50	GI042	PC50
	PCLNR 4040 S 19	40	40	40	50	250	45	-6	-6	3.19	GI042	PC50
	PCLNR 4040 S 25	40	40	40	50	250	45	-6	-6	3.15	GI062	PC60
	PCLNR 5050 T 25	50	50	50	60	300	50	-6	-6	5.90	GI062	PC60
	L	PCLNL 2020 K 12	20	20	20	25	125	36	-6	-6	0.42	GI043
PCLNL 2525 M 12		25	25	25	32	150	36	-6	-6	0.75	GI043	PC20
PCLNL 3225 P 12		32	25	32	32	170	36	-6	-6	1.10	GI043	PC20
PCLNL 3225 P 16		32	25	32	32	170	40	-6	-6	1.10	GI050	PC40
PCLNL 3232 P 19		32	32	32	40	170	45	-6	-6	1.42	GI042	PC50
PCLNL 4040 R 19		40	40	40	50	200	45	-6	-6	2.60	GI042	PC50
PCLNL 4040 S 19		40	40	40	50	250	45	-6	-6	3.19	GI042	PC50
PCLNL 4040 S 25		40	40	40	50	250	45	-6	-6	2.45	GI062	PC60
PCLNL 5050 T 25		50	50	50	60	300	50	-6	-6	5.90	GI062	PC60



GI042
GI043
GI050
GI062

CN.. 1906..
CN.. 1204..
CN.. 1606..
CN.. 2509..



				 Nm					
PC20	CNU 120312	PU 02	US 35	6.0	M 8x1	22.5	NT 05	MT 05	HXX 4
PC22	CNU 120312	PU 02	US 42	6.0	M 8x1	21	NT 05	MT 05	HXX 4
PC40	CNU 150312	PU 04	US 36	6.0	M 8x1	26	NT 07	MT 07	HXX 4
PC50	CNU 190416	PU 05	US 38	8.0	M 10x1	29	NT 06	MT 06	HXX 5
PC60	CNU 250620	PU 06	US 39	8.0	M 10x1	33	NT 08	MT 08	HXX 5

NEW
C.-DCLN(RL) EXT

PRAMET
D

CN.. Uç için Çift Sıkmalı, 95° Açılı Hızlı Değişirme Dış Takımı

Çift sıkmalı, 95° açılı, içten su vermeli Sağ/Sol dış kater. Negatif CN.. 12 veya 19 uçlarla çap, alın, konik ve pah tornalamak için uygundur. C4 - C6 şaftlı mevcuttur. Tutucu uzun takım ömrü için işlem görmüştür.

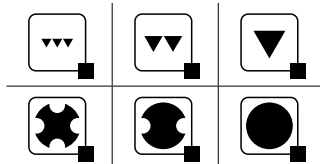
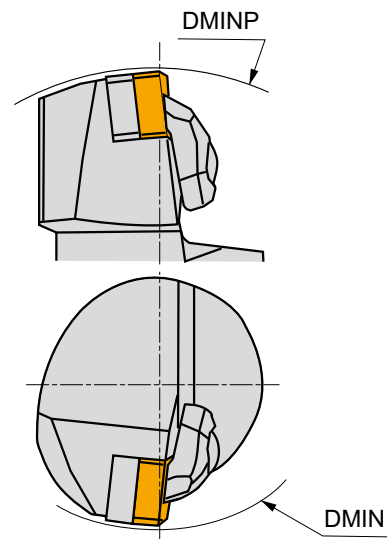
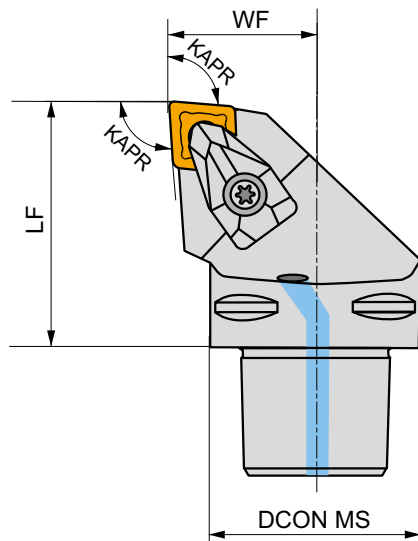
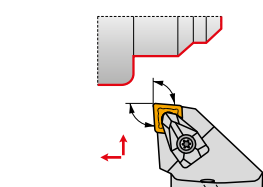

Product	DCON MS	DMIN	DMINP	WF	LF	KAPR	LAMS	GAMO	✓	kg	GI043	C-DC12	AT001	
	(mm)	(mm)	(mm)	(mm)	(mm)	(°)	(°)	(°)						
R	C3-DCLNR-22045-12	32	60	121	22	45	95	-6	-6	✓	0.25	GI043	C-DC12	AT001
	C4-DCLNR-27050-12	40	110	140	27	50	95	-6	-6	✓	0.44	GI043	C-DC12	AT001
	C4-DCLNR-27055-16	40	125	145	27	55	95	-6	-6	✓	0.47	GI050	C-DC16	AT005
	C5-DCLNR-35060-12	50	110	165	35	60	95	-6	-6	✓	0.79	GI043	C-DC12	AT001
	C5-DCLNR-35060-16	50	125	165	35	60	95	-6	-6	✓	0.80	GI050	C-DC16	AT005
	C6-DCLNR-45065-12	63	110	190	45	65	95	-6	-6	✓	1.32	GI043	C-DC12	AT001
	C6-DCLNR-45065-16	63	125	190	45	65	95	-6	-6	✓	1.34	GI050	C-DC16	AT005
	C6-DCLNR-45065-19	63	81	190	45	65	95	-6	-6	✓	1.34	GI042	C-DC19	-
C8-DCLNR-55080-19	80	100	250	55	80	95	-6	-6	✓	2.58	GI042	C-DC19	-	
L	C4-DCLNL-27050-12	40	110	140	27	50	95	-6	-6	✓	0.44	GI043	C-DC12	AT001
	C4-DCLNL-27055-16	40	125	145	27	55	95	-6	-6	✓	0.48	GI050	C-DC16	AT005
	C5-DCLNL-35060-12	50	110	165	35	60	95	-6	-6	✓	0.79	GI043	C-DC12	AT001
	C5-DCLNL-35060-16	50	125	165	35	60	95	-6	-6	✓	0.80	GI050	C-DC16	AT005
	C6-DCLNL-45065-12	63	110	190	45	65	95	-6	-6	✓	1.32	GI043	C-DC12	AT001
	C6-DCLNL-45065-16	63	125	190	45	65	95	-6	-6	✓	1.34	GI050	C-DC16	AT005
	C6-DCLNL-45065-19	63	81	190	45	65	95	-6	-6	✓	1.34	GI042	C-DC19	-
	C8-DCLNL-55080-16	80	125	250	55	80	95	-6	-6	✓	2.58	GI050	C-DC16	AT005
C8-DCLNL-55080-19	80	100	250	55	80	95	-6	-6	✓	2.58	GI042	C-DC19	-	



GI042

CN.. 1906..









GI043





CN.. 1204..

GI050

CN.. 1606..



		 Nm					
C-DC12	DCS 12	3.9	DCS 234-01	US 2002-T15P	FLAG T15P/3,5	–	CN 045-01
C-DC16	DCS 16	6.4	DCS 234-03	US 2007-T20P	–	LK T20P	CN 045-01
C-DC19	DCS 19	6.4	DCS 236-01	US 2007-T20P	–	LK T20P	CN 045-01

			
AT001a	CN.. 1207..	–	DCS 234-02
AT005a	CN.. 1607..	–	DCS 234-04
AT001b	CER CN.N 1204..	DCS 12C4	–
AT001c	CER CN.A 1204..	DCS 12C2	–
AT005b	CER CN.N 1606..	DCS 16C4	–
AT005c	CER CN.A 1606..	DCS 16C2	–



KHP-CBN(RL)



PRAMET

P



Modüler KHP Levyeleli Torna Kartuşu, 75° Kesme Açılı, CN.. Uç için

DKH takım tutucu shaft için kırılmalı bağlantılı, 75° açılı Sağ/Sol levyeleli kartuş. Negatif CN..25 uçlarla çap, alın, konik ve pah tornalamak için uygundur. Tutucu uzun takım ömrü için işlem görmüştür.

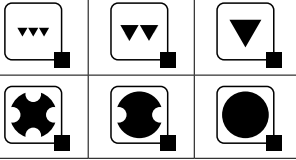
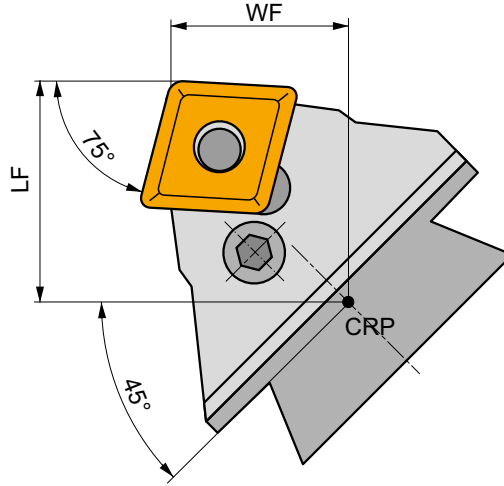
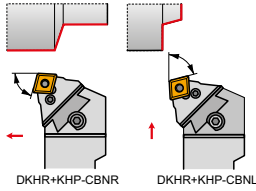

Product	WF (mm)	LF (mm)	LAMS (°)	GAMO (°)	kg		
R KHP-CBNR 25	32	47	-6	-6	1.54	GI062	PC60
L KHP-CBNL 25	32	47	-6	-6	1.56	GI062	PC60



GI062



CN.. 2509..



PC60



CNU 250620



PU 06



US 39



8.0



M 10x1



33



NT 08



MT 08



HXK 5



KHP-CLN(RL)



PRAMET

P



Modüler KHP Levveli Torna Kartuşu, 95° Kesme Açı, CN.. Uç için

DKH takım tutucu şaft için kırılmaç bağlantılı, 95° açılı Sağ/Sol levyeli kartuş. Negatif CN.. 19 veya 25 uçlarla çap, alın, konik ve pah tornalamak için uygundur. Tutucu uzun takım ömrü için işlem görmüştür.

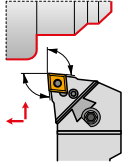

DKHR+KHP-CLNR

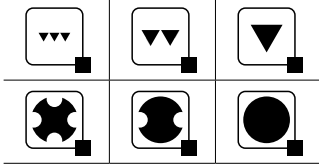
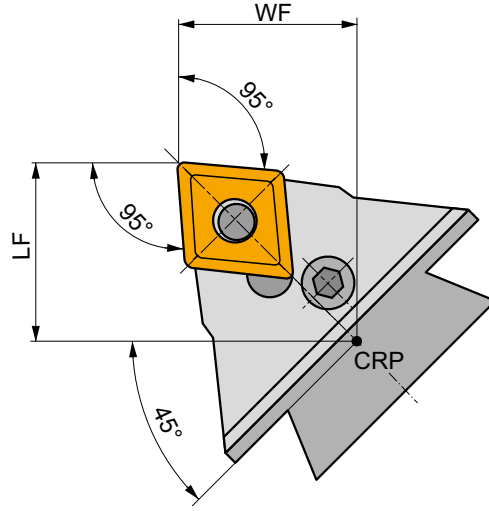

Product	WF	LF	LAMS	GAMO	kg	GI042	GI062
	(mm)	(mm)	(°)	(°)			
R KHP-CLNR 19	35	45	-6	-6	1.30	GI042	PC50
	KHP-CLNR 25	35	45	-6	-6	1.25	GI062
L KHP-CLNL 19	35	45	-6	-6	1.30	GI042	PC50
	KHP-CLNL 25	35	45	-6	-6	1.25	GI062

GI042	GI062	Product	WF	LF	LAMS	GAMO	kg	GI042	GI062

PC50	CNU 190416	PU 05	US 38	8.0	M 10x1	29	NT 06	MT 06	HXK 5
PC60	CNU 250620	PU 06	US 39	8.0	M 10x1	33	NT 08	MT 08	HXK 5



DKH(RL)



KHP/KHS Ağır Tornalama Kartuşları için Dış Kater Şaftı

KHP/KHS kartuşlar için kırlangıçlı Sağ/Sol takım şaftı. Ağır tornalama için uygundur. 40x50'den 60x80mm'ye kadar mevcut. Gövde uzun takım ömrü için işlem görmüştür.

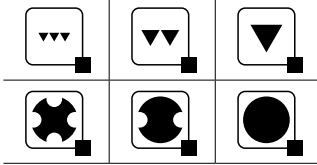
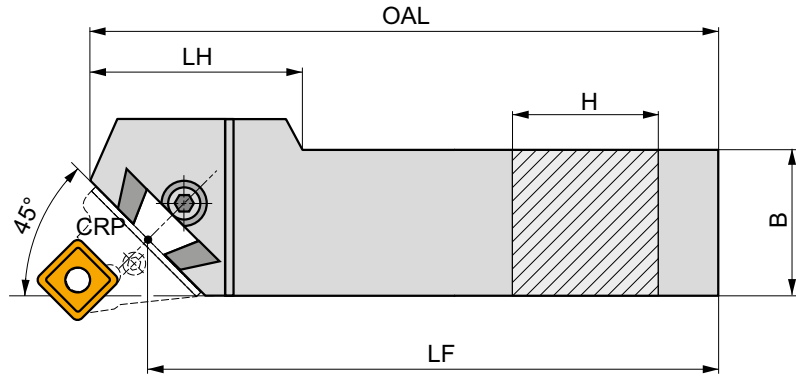
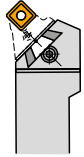

Product	H	B	LF	OAL	LH	kg		
	(mm)	(mm)	(mm)	(mm)	(mm)			
R	DKHR 4050 V	40	50	400	425	7.10	GI098	DKH10
	DKHR 5060 W	50	60	450	475	11.30	GI098	DKH10
	DKHR 6080 W-A	60	80	450	485	19.65	GI098	DKH10
L	DKHL 4050 V	40	50	400	425	7.10	GI098	DKH10
	DKHL 5060 W	50	60	450	475	11.30	GI098	DKH10
	DKHL 6080 W-A	60	80	450	485	19.28	GI098	DKH10



GI098



KHP



KHS



DKH10



SR 14



HXK 10



DCLN(RL) INT



PRAMET

D



CN.. Uç için Çift Sıkmalı 95° Açılı Delik Kateri

Çift sıkmalı 95° Sağ/Sol içten su vermeli delik kateri. Negatif CN.. 09 veya 12 uçlarla minimum Ø32mm çap, konik ve pah tornalama için uygundur. Ø25-40mm shaft ölçüleri. Gövde uzun takım ömrü için işlem görmüştür.

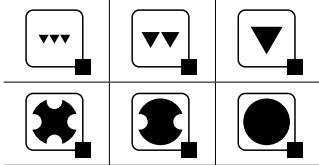
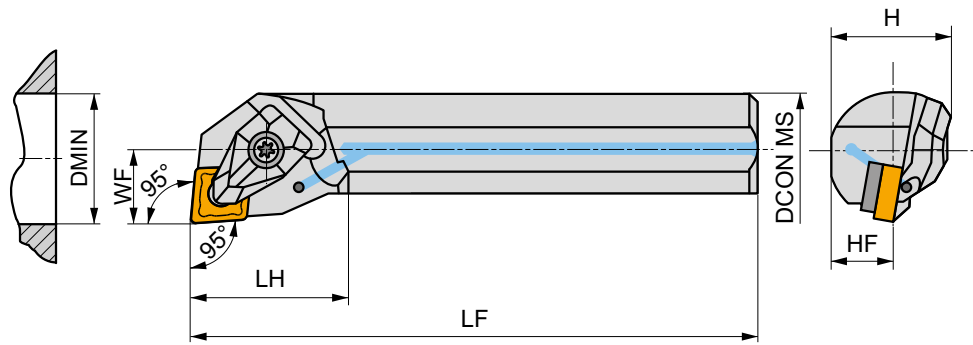
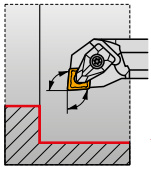

Product	DCON MS (mm)	DMIN (mm)	WF (mm)	H (mm)	HF (mm)	LF (mm)	LH (mm)	LAMS (°)	GAMO (°)				
R A25T-DCLNR 09	25	32	17	23	11.5	300	31	-11	-6	✓	1.13	GI133	DC09
A25T-DCLNR 12	25	32	17	23	11.5	300	31	-12	-6	✓	1.12	GI043	DC12
A32T-DCLNR 12	32	40	22	30	15	300	30	-10	-6	✓	1.68	GI043	DC12
A40T-DCLNR 12	40	50	27	37	18.5	300	32	-15	-6	✓	2.56	GI043	DC12
L A25T-DCLNL 09	25	32	17	23	11.5	300	31	-11	-6	✓	1.12	GI133	DC09
A25T-DCLNL 12	25	32	17	23	11.5	300	31	-12	-6	✓	1.11	GI043	DC12
A32T-DCLNL 12	32	40	22	30	15	300	30	-10	-6	✓	1.68	GI043	DC12
A40T-DCLNL 12	40	50	27	37	18.5	300	32	-15	-6	✓	2.56	GI043	DC12



GI043
GI133

CN.. 1204..
CN.. 0903..



DC09
DC12
DC112

DCS 09
DCS 12
DCS 12

1.7
3.9
3.9

DCS 236-04
DCS 234-01
DCS 236-03

US 2004-T09P
US 2002-T15P
US 2002-T15P

FLAG T09P
FLAG T15P/3,5
FLAG T15P/3,5



PCLN(RL) INT



PRAMET

P



CN.. Uç için Levye 95° Açılı Delik Kateri

Levyeli 95° Sağ/Sol içten su vermeli delik kateri. Negatif CN.. 09-19 uçlarla minimum Ø20mm çap, konik ve pah tormalama için uygundur. Ø16-60mm shaft ölçüleri. Gövde uzun takım ömrü için işlem görmüştür.

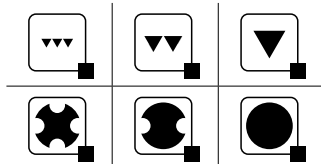
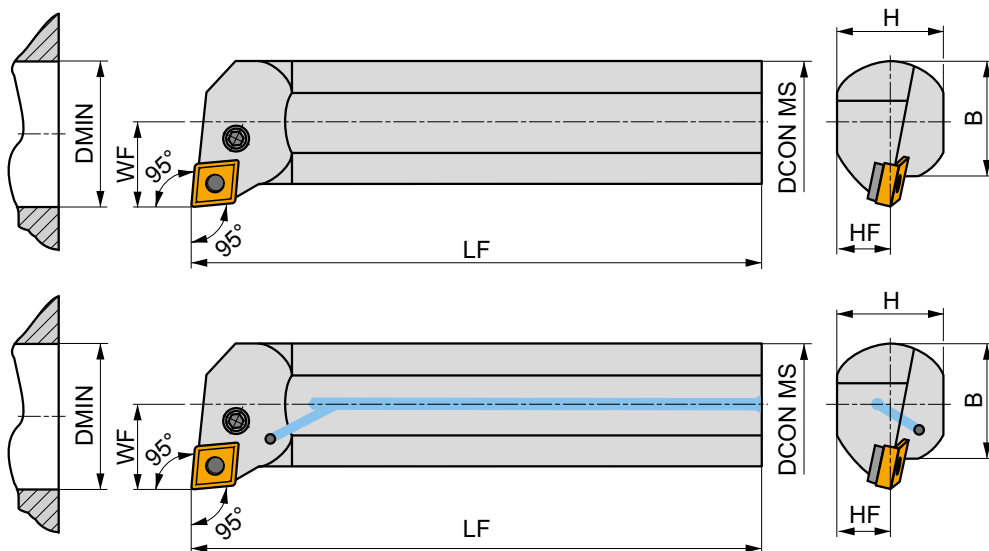
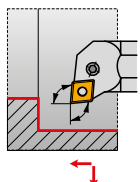

Product	DCON MS	DMIN	WF	H	B	LF	LAMS	GAMO		kg		
	(mm)	(mm)	(mm)	(mm)	(mm)	(mm)	(°)	(°)				
R	A16M-PCLNR 09	16	20	11	15	15	-13.5	-5	✓	0.22	GI133	PC09
	A20Q-PCLNR 09	20	25	13	18	18	-13.5	-5	✓	0.36	GI133	PC09
	A25R-PCLNR 12	25	32	17	23	23	-13	-7	✓	0.65	GI043	PC25
	S25T-PCLNR 12	25	32	17	23	23	-13	-7	-	1.10	GI043	PC25
	A32S-PCLNR 12	32	40	22	30	30	-12	-6	✓	1.48	GI043	PC21
	A40T-PCLNR 12	40	50	27	38	38	-12	-6	✓	2.40	GI043	PC20
	A40T-PCLNR 16	40	50	27	38	38	-12	-6	✓	2.90	GI050	PC41
	A50U-PCLNR 16	50	63	35	47	48.5	-12	-6	✓	5.20	GI050	PC40
	A60V-PCLNR 16	60	80	43	57	58.5	-12	-6	✓	8.70	GI050	PC40
	A50U-PCLNR 19	50	63	35	47	48.5	-12	-6	✓	5.20	GI042	PC50
A60V-PCLNR 19	60	80	43	57	58.5	-12	-6	✓	8.22	GI042	PC50	
L	A16M-PCLNL 09	16	20	11	15	15	-13.5	-5	✓	0.20	GI133	PC09
	A20Q-PCLNL 09	20	25	13	18	18	-13.5	-5	✓	0.34	GI133	PC09
	A25R-PCLNL 12	25	32	17	23	23	-13	-7	✓	0.65	GI043	PC25
	S25T-PCLNL 12	25	32	17	23	23	-13	-7	-	1.15	GI043	PC25
	A32S-PCLNL 12	32	40	22	30	30	-12	-6	✓	1.48	GI043	PC21
	A40T-PCLNL 12	40	50	27	38	38	-12	-6	✓	2.58	GI043	PC20
	A40T-PCLNL 16	40	50	27	38	38	-12	-6	✓	2.58	GI050	PC41
	A50U-PCLNL 16	50	63	35	47	48.5	-12	-6	✓	4.95	GI050	PC40
	A60V-PCLNL 16	60	80	43	57	58.5	-12	-6	✓	8.70	GI050	PC40
	A50U-PCLNL 19	50	63	35	47	48.5	-12	-6	✓	5.20	GI042	PC50
A60V-PCLNL 19	60	80	43	57	58.5	-12	-6	✓	8.40	GI042	PC50	



GI042
GI043



CN.. 1906..
CN.. 1204..



GI050

CN.. 1606..

GI133

CN.. 0903..

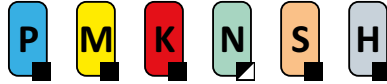

PC09	–	PU 8451	PS 8290	2.0	M 5	12	–	–	HXX 2
PC20	CNU 120312	PU 02	US 35	6.0	M 8x1	22.5	NT 05	MT 05	HXX 4
PC21	CNU 120312	PU 02	US 41	6.0	M 8x1	17	NT 05	MT 05	HXX 4
PC25	–	PU 32	US 46	5.0	M 6x0.75	13.2	–	–	HXX 3
PC40	CNU 150312	PU 04	US 36	6.0	M 8x1	26	NT 07	MT 07	HXX 4
PC41	CNU 150312	PU 04	US 40	6.0	M 8x1	20.5	NT 07	MT 07	HXX 4
PC50	CNU 190416	PU 05	US 38	8.0	M 10x1	29	NT 06	MT 06	HXX 5

NEW
C.-DCLN(RL) INT

PRAMET
D

CN.. Uçlar için Çift Sıkmalı 95° Açılı PSC Hızlı Değişirme Delik Takımı

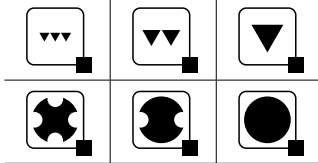
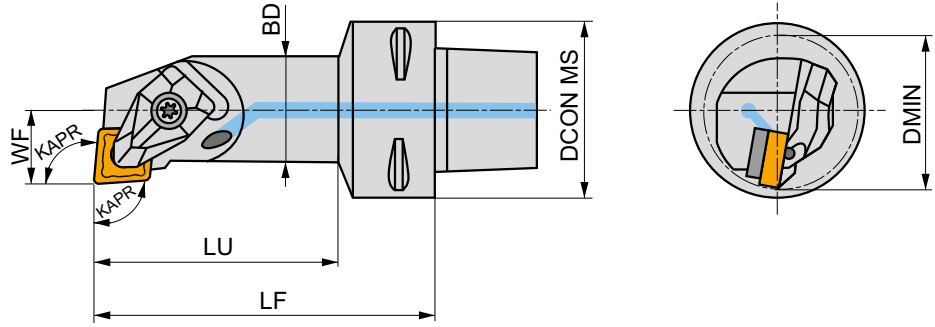
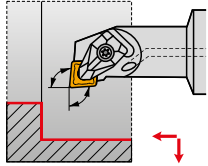
Çift sıkmalı 95° Sağ/Sol içten su vermeli delik kateri. Negatif CN.. 09-16 uçlarla minimum Ø25mm çap, ve birçok çeşit tornalama için uygundur. PSC C4-6 shaft ölçüleri. Gövde uzun takım ömrü için işlem görmüştür.



Product	DCON MS (mm)	DMIN (mm)	WF (mm)	LF (mm)	LU (mm)	BD (mm)	KAPR (°)	LAMS (°)	GAMO (°)					
R	C4-DCLNR-13080-09	40	25	13	80	57	20	95	-14	-6	✓	0.43	GI133	DC09
	C4-DCLNR-17090-12	40	32	17	90	68	25	95	-12	-6	✓	0.53	GI043	DC12
	C5-DCLNR-17090-12	50	32	17	90	66	25	95	-12	-6	✓	0.72	GI043	DC12
	C6-DCLNR-17100-12	63	32	17	100	72	25	95	-12	-6	✓	1.15	GI043	DC12
	C6-DCLNR-27140-16	63	50	27	140	114	40	95	-16	-6	✓	1.81	GI050	DC16
L	C4-DCLNL-17090-12	40	32	17	90	68	25	95	-12	-6	✓	0.53	GI043	DC12
	C5-DCLNL-17090-12	50	32	17	90	66	25	95	-12	-6	✓	0.72	GI043	DC12



GI043

CN.. 1204..

GI050

CN.. 1606..

GI133

CN.. 0903..



DC09

DCS 09

1.7

DCS 236-04

US 2004-T09P

FLAGT09P

-

DC16

DCS 16

6.4

DCS 234-03

US 2007-T20P

-

LKT20P

DC12

DCS 12

3.9

DCS 236-03

US 2002-T15P

FLAG T15P/3,5

-



DN

11/ 15

KARBÜR UÇLAR

DNMA	DNMG	DNMM
260	260	270

CER VE CBN UÇLAR

DNGA CER	DNGN CER	DNGA CBN
271	271	272

DOĞRU BOYUTLA EŞLEŞTİRİN (örnek)

Kesici uç	Takım Tutucu
DNMG 150404E-SF	DDJNL 2020 K 15

ISO TORNALAMA - DIŞ











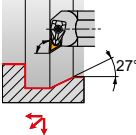
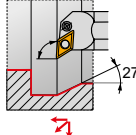
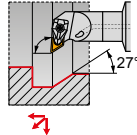

DDJN(RL) EXT	PDJN(RL) EXT	PDNN(RL) EXT	PDXN(RL) EXT
<p>93°</p> <p>DN..</p> <p>11 15</p> <p>20×20 32×32</p> <p> 273</p>	<p>93°</p> <p>DN..</p> <p>11 15</p> <p>20×20 32×32</p> <p> 274</p>	<p>62°30'</p> <p>DN..</p> <p>11 15</p> <p>20×20 32×25</p> <p> 275</p>	<p>98°</p> <p>DN..</p> <p>15</p> <p>20×20 32×25</p> <p> 276</p>
C.-DDJN(RL) EXT NEW	C.-DDNNN EXT NEW	C.-DDUN(RL) EXT NEW	
<p>93°</p> <p>DN..</p> <p>11 15</p> <p>C4 C6</p> <p> 277</p>	<p>62,5°</p> <p>DN..</p> <p>15</p> <p>C5 C6</p> <p> 278</p>	<p>93°</p> <p>DN..</p> <p>15</p> <p>C5 C6</p> <p> 279</p>	



DN

11/ 15

ISO TORNALAMA - İÇ

DDUN(RL) INT		PDUN(RL) INT		C.-DDUN(RL) INT NEW	
93°	DN.. 	93°	DN.. 	93°	DN.. 
	11 15		11 15		11
 $\frac{25}{50}$		 $\frac{25}{60}$		 12	
 280	 260 – 272	 281	 260 – 272	 282	 260 – 272



DNMA

	IC (mm)	D1 (mm)	L (mm)	S (mm)
1504	12.700	5.16	15.50	4.76
1506	12.700	5.16	15.50	6.35

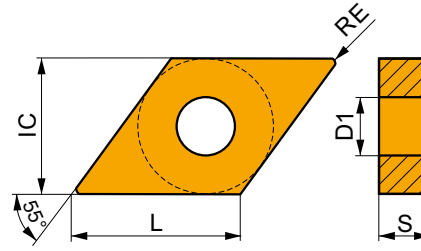

Kesme hızı (vc), ilerleme (f) ve kesme derinliği (ap) için uygunluk ve başlangıç değerleri. Daha ileri hesaplamalar için İşleme Hesaplayıcısı uygulamasına başvurun.

Product	RE	P			M			K			N			S			H		
		vc (m/min)	f (mm/rev)	ap (mm)	vc (m/min)	f (mm/rev)	ap (mm)	vc (m/min)	f (mm/rev)	ap (mm)	vc (m/min)	f (mm/rev)	ap (mm)	vc (m/min)	f (mm/rev)	ap (mm)			

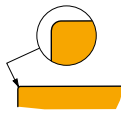

İnce finişten yarı kaba işleme kadar ve darbesizden hafif darbeli kesmeye kadar uygun.

DNMA 150404	T5305	0.4	-	-	-	-	-	-	205	0.10	1.7	-	-	-	-	-	-	40	0.15	1.0
DNMA 150408	T5305	0.8	-	-	-	-	-	-	190	0.20	1.7	-	-	-	-	-	-	40	0.15	1.0
	T5315	0.8	-	-	-	-	-	-	165	0.20	1.7	-	-	-	-	-	-	35	0.15	1.0
DNMA 150604	T5305	0.4	-	-	-	-	-	-	205	0.10	1.7	-	-	-	-	-	-	40	0.15	1.0
	T5315	0.4	-	-	-	-	-	-	180	0.10	1.7	-	-	-	-	-	-	35	0.15	1.0
	T6310	0.4	-	-	-	-	-	-	85	0.10	1.7	-	-	-	-	-	-	20	0.15	1.0
DNMA 150608	T5305	0.8	-	-	-	-	-	-	190	0.20	1.7	-	-	-	-	-	-	40	0.15	1.0
	T5315	0.8	-	-	-	-	-	-	165	0.20	1.7	-	-	-	-	-	-	35	0.15	1.0
	T6310	0.8	-	-	-	-	-	-	85	0.20	1.7	-	-	-	-	-	-	20	0.15	1.0
DNMA 150612	T5305	1.2	-	-	-	-	-	-	200	0.20	1.7	-	-	-	-	-	-	40	0.15	1.0
	T5315	1.2	-	-	-	-	-	-	175	0.20	1.7	-	-	-	-	-	-	35	0.15	1.0

DNMG

	IC (mm)	D1 (mm)	L (mm)	S (mm)
1104	9.525	3.81	11.60	4.76
1504	12.700	5.16	15.50	4.76
1506	12.700	5.16	15.50	6.35

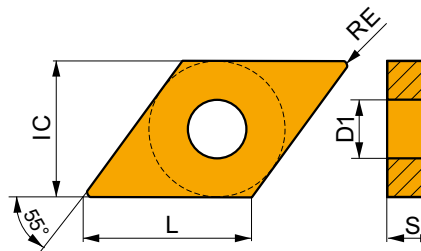

Kesme hızı (vc), ilerleme (f) ve kesme derinliği (ap) için uygunluk ve başlangıç değerleri. Daha ileri hesaplamalar için İşleme Hesaplayıcısı uygulamasına başvurun.

Product	RE	P			M			K			N			S			H		
		vc (m/min)	f (mm/rev)	ap (mm)	vc (m/min)	f (mm/rev)	ap (mm)	vc (m/min)	f (mm/rev)	ap (mm)	vc (m/min)	f (mm/rev)	ap (mm)	vc (m/min)	f (mm/rev)	ap (mm)			

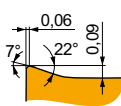

FF geometri, ince-finiş işleme için çok pozitif tasarım, darbesizden hafif darbeli işleme kadar uygun.

DNMG 110402E-FF	T8315	0.2	175	0.10	0.8	105	0.09	0.8	165	0.10	0.8	-	-	-	-	-	-	-	-	-
DNMG 110404E-FF	T8315	0.4	175	0.12	0.8	105	0.11	0.8	165	0.12	0.8	-	-	-	-	-	-	-	-	-
	T8330	0.4	165	0.12	0.8	95	0.11	0.8	155	0.12	0.8	-	-	-	-	-	-	-	-	-
	T8430	0.4	205	0.12	0.8	110	0.11	0.8	170	0.12	0.8	-	-	-	-	-	-	-	-	-
DNMG 110408E-FF	T8315	0.8	200	0.15	0.8	120	0.14	0.8	190	0.15	0.8	-	-	-	-	-	-	-	-	-



Kesme hızı (vc), ilerleme (f) ve kesme derinliği (ap) için uygunluk ve başlangıç değerleri. Daha ileri hesaplamalar için İşleme Hesaplayıcısı uygulamasına başvurun.

Product	RE (mm)	P			M			K			N			S			H		
		vc (m/min)	f (mm/rev)	ap (mm)	vc (m/min)	f (mm/rev)	ap (mm)	vc (m/min)	f (mm/rev)	ap (mm)	vc (m/min)	f (mm/rev)	ap (mm)	vc (m/min)	f (mm/rev)	ap (mm)	vc (m/min)	f (mm/rev)	ap (mm)

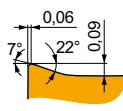

FF geometri, ince-finiş işleme için çok pozitif tasarım, darbesizden hafif darbeli işleme kadar uygun.

DNMG 150404E-FF	T8315	0.4	175	0.12	1.0	105	0.11	1.0	165	0.12	1.0	-	-	-	-	-	-	-
	T7325	0.4	190	0.12	1.0	145	0.11	1.0	-	-	-	-	-	-	-	-	-	-
DNMG 150604E-FF	T8315	0.4	175	0.12	1.0	105	0.11	1.0	165	0.12	1.0	-	-	-	-	-	-	-
	T7325	0.8	210	0.15	1.0	160	0.14	1.0	-	-	-	-	-	-	-	-	-	-
DNMG 150608E-FF	T8315	0.8	195	0.15	1.0	115	0.14	1.0	185	0.15	1.0	-	-	-	-	-	-	-

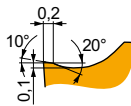

FM pozitif geometri, finişten yarı kaba işleme, ve darbesizden hafif darbeli kesmeye kadar uygun.

DNMG 110404E-FM	T7325	0.4	165	0.20	0.8	125	0.18	0.8	-	-	-	50	0.20	0.6	-	-	-	
	T8315	0.4	150	0.20	0.8	90	0.18	0.8	140	0.20	0.8	35	0.14	0.6	-	-	-	
	T8330	0.4	145	0.20	0.8	85	0.18	0.8	135	0.20	0.8	35	0.14	0.6	-	-	-	
	T8430	0.4	165	0.20	0.8	90	0.18	0.8	135	0.20	0.8	35	0.14	0.6	-	-	-	
	T9310	0.4	245	0.20	0.8	-	-	-	230	0.20	0.8	-	-	-	-	-	-	-
	T9315	0.4	225	0.20	0.8	-	-	-	210	0.20	0.8	-	-	-	-	-	-	-
	T9325	0.4	200	0.20	0.8	120	0.18	0.8	190	0.20	0.8	45	0.20	0.6	-	-	-	
DNMG 110408E-FM	T7325	0.8	200	0.20	0.8	155	0.18	0.8	-	-	-	65	0.16	0.6	-	-	-	
	T8315	0.8	180	0.20	0.8	105	0.18	0.8	170	0.20	0.8	45	0.14	0.6	-	-	-	
	T8330	0.8	175	0.20	0.8	105	0.18	0.8	165	0.20	0.8	40	0.14	0.6	-	-	-	
	T8430	0.8	195	0.20	0.8	105	0.18	0.8	160	0.20	0.8	40	0.14	0.6	-	-	-	
	T9310	0.8	295	0.20	0.8	-	-	-	280	0.20	0.8	-	-	-	-	-	-	
	T9315	0.8	270	0.20	0.8	-	-	-	255	0.20	0.8	-	-	-	-	-	-	
	T9325	0.8	240	0.20	0.8	140	0.18	0.8	225	0.20	0.8	50	0.16	0.6	-	-	-	
DNMG 150404E-FM	T7325	0.4	150	0.20	1.7	115	0.18	1.7	-	-	-	45	0.20	1.4	-	-	-	
	T8330	0.4	135	0.20	1.7	80	0.18	1.7	125	0.20	1.7	30	0.14	1.4	-	-	-	
	T8430	0.4	150	0.20	1.7	80	0.18	1.7	125	0.20	1.7	30	0.14	1.4	-	-	-	
	T9315	0.4	210	0.20	1.7	-	-	-	195	0.20	1.7	-	-	-	-	-	-	
	T9325	0.4	190	0.20	1.7	110	0.18	1.7	180	0.20	1.7	40	0.20	1.4	-	-	-	
	T9310	0.4	210	0.20	1.7	-	-	-	235	0.20	1.7	-	-	-	-	-	-	
DNMG 150408E-FM	T7325	0.8	180	0.20	1.7	140	0.18	1.7	-	-	-	55	0.16	1.4	-	-	-	
	T8330	0.8	160	0.20	1.7	95	0.18	1.7	150	0.20	1.7	40	0.16	1.4	-	-	-	
	T8430	0.8	185	0.20	1.7	100	0.18	1.7	150	0.20	1.7	40	0.16	1.4	-	-	-	
	T9315	0.8	250	0.20	1.7	-	-	-	235	0.20	1.7	-	-	-	-	-	-	
	T9325	0.8	225	0.20	1.7	135	0.18	1.7	210	0.20	1.7	50	0.16	1.4	-	-	-	
	T7325	0.4	150	0.20	1.7	115	0.18	1.7	-	-	-	45	0.20	1.4	-	-	-	
	T7335	0.4	150	0.20	1.7	115	0.18	1.7	-	-	-	45	0.20	1.4	-	-	-	
	T8315	0.4	140	0.20	1.7	80	0.18	1.7	130	0.20	1.7	35	0.14	1.4	-	-	-	
	T8330	0.4	135	0.20	1.7	80	0.18	1.7	125	0.20	1.7	30	0.14	1.4	-	-	-	
	T8430	0.4	150	0.20	1.7	80	0.18	1.7	125	0.20	1.7	30	0.14	1.4	-	-	-	
DNMG 150604E-FM	T9310	0.4	230	0.20	1.7	-	-	-	215	0.20	1.7	-	-	-	-	-	-	
	T9315	0.4	210	0.20	1.7	-	-	-	195	0.20	1.7	-	-	-	-	-	-	
	T9325	0.4	190	0.20	1.7	110	0.18	1.7	180	0.20	1.7	40	0.20	1.4	-	-	-	
	TT310	0.4	210	0.20	1.7	125	0.18	1.7	-	-	-	-	-	-	-	-	-	
	T7325	0.8	180	0.20	1.7	140	0.18	1.7	-	-	-	55	0.16	1.4	-	-	-	
	T7335	0.8	175	0.20	1.7	135	0.18	1.7	-	-	-	55	0.16	1.4	-	-	-	
	T8315	0.8	170	0.20	1.7	100	0.18	1.7	160	0.20	1.7	40	0.16	1.4	-	-	-	
	T8330	0.8	160	0.20	1.7	95	0.18	1.7	150	0.20	1.7	40	0.16	1.4	-	-	-	
	T8430	0.8	185	0.20	1.7	100	0.18	1.7	150	0.20	1.7	40	0.16	1.4	-	-	-	
	T9310	0.8	275	0.20	1.7	-	-	-	260	0.20	1.7	-	-	-	-	-	-	
DNMG 150608E-FM	T9315	0.8	250	0.20	1.7	-	-	-	235	0.20	1.7	-	-	-	-	-	-	
	T9325	0.8	225	0.20	1.7	135	0.18	1.7	210	0.20	1.7	50	0.16	1.4	-	-	-	
	TT310	0.8	250	0.20	1.7	150	0.18	1.7	-	-	-	-	-	-	-	-	-	
	T7325	1.2	180	0.25	1.7	140	0.23	1.7	-	-	-	55	0.18	1.4	-	-	-	
	T8430	1.2	175	0.25	1.7	95	0.23	1.7	140	0.25	1.7	35	0.18	1.4	-	-	-	
	T9310	1.2	260	0.25	1.7	-	-	-	245	0.25	1.7	-	-	-	-	-	-	
	T9315	1.2	240	0.25	1.7	-	-	-	225	0.25	1.7	-	-	-	-	-	-	
	T9325	1.2	215	0.25	1.7	125	0.23	1.7	200	0.25	1.7	45	0.18	1.4	-	-	-	



Kesme hızı (vc), ilerleme (f) ve kesme derinliği (ap) için uygunluk ve başlangıç değerleri. Daha ileri hesaplamalar için İşleme Hesaplayıcısı uygulamasına başvurun.

Product	RE (mm)	P			M			K			N			S			H			
		vc	f	ap	vc	f	ap	vc	f	ap	vc	f	ap	vc	f	ap	vc	f	ap	
		(m/min)	(mm/rev)	(mm)	(m/min)	(mm/rev)	(mm)	(m/min)	(mm/rev)	(mm)	(m/min)	(mm/rev)	(mm)	(m/min)	(mm/rev)	(mm)	(m/min)	(mm/rev)	(mm)	(m/min)

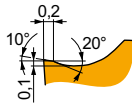

FM pozitif geometri, finişten yarı kaba işlemeye, ve darbesizden hafif darbeli kesmeye kadar uygun.

DNMG 150616E-FM	T9315	1.6	235	0.30	1.7	—	—	—	220	0.30	1.7	—	—	—	—	—	—	—	—	—	—	—
	T9325	1.6	210	0.30	1.7	125	0.27	1.7	195	0.30	1.7	—	—	—	45	0.21	1.4	—	—	—	—	—

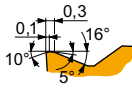

M geometri, finişten yarı kaba işlemeye kadar ve darbesizden darbeli kesime kadar uygun.

DNMG 110404E-M	T5315	0.4	210	0.20	1.2	—	—	—	195	0.20	1.2	—	—	—	—	—	—	40	0.15	1.0	—	—	—
	T9315	0.4	195	0.20	1.2	—	—	—	185	0.20	1.2	—	—	—	—	—	—	35	0.15	1.0	—	—	—
	T9325	0.4	175	0.20	1.2	—	—	—	165	0.20	1.2	—	—	—	—	—	—	—	—	—	—	—	—
	T9335	0.4	150	0.20	1.2	—	—	—	—	—	—	—	—	—	—	—	—	—	—	—	—	—	—
DNMG 110408E-M	T5315	0.8	215	0.30	1.2	—	—	—	200	0.30	1.2	—	—	—	—	—	—	40	0.15	1.0	—	—	—
	T9315	0.8	200	0.30	1.2	—	—	—	190	0.30	1.2	—	—	—	—	—	—	40	0.15	1.0	—	—	—
	T9325	0.8	175	0.30	1.2	—	—	—	165	0.30	1.2	—	—	—	—	—	—	—	—	—	—	—	—
	T9335	0.8	155	0.30	1.2	—	—	—	—	—	—	—	—	—	—	—	—	—	—	—	—	—	—
DNMG 110412E-M	T9315	1.2	185	0.40	1.2	—	—	—	175	0.40	1.2	—	—	—	—	—	—	35	0.15	1.0	—	—	—
	T9325	1.2	165	0.40	1.2	—	—	—	155	0.40	1.2	—	—	—	—	—	—	—	—	—	—	—	—
	T9335	1.2	140	0.40	1.2	—	—	—	—	—	—	—	—	—	—	—	—	—	—	—	—	—	—
DNMG 150404E-M	T5315	0.4	200	0.20	1.9	—	—	—	190	0.20	1.9	—	—	—	—	—	—	40	0.15	1.0	—	—	—
	T9315	0.4	190	0.20	1.9	—	—	—	180	0.20	1.9	—	—	—	—	—	—	35	0.15	1.0	—	—	—
	T9325	0.4	170	0.20	1.9	—	—	—	160	0.20	1.9	—	—	—	—	—	—	—	—	—	—	—	—
	T9335	0.4	145	0.20	1.9	—	—	—	—	—	—	—	—	—	—	—	—	—	—	—	—	—	—
DNMG 150408E-M	T5315	0.8	205	0.30	1.9	—	—	—	190	0.30	1.9	—	—	—	—	—	—	40	0.15	1.0	—	—	—
	T9315	0.8	190	0.30	1.9	—	—	—	180	0.30	1.9	—	—	—	—	—	—	35	0.15	1.0	—	—	—
	T9325	0.8	170	0.30	1.9	—	—	—	160	0.30	1.9	—	—	—	—	—	—	—	—	—	—	—	—
	T9335	0.8	145	0.30	1.9	—	—	—	—	—	—	—	—	—	—	—	—	—	—	—	—	—	—
DNMG 150412E-M	T5315	1.2	200	0.40	1.9	—	—	—	190	0.40	1.9	—	—	—	—	—	—	40	0.15	1.0	—	—	—
	T9315	1.2	175	0.40	1.9	—	—	—	165	0.40	1.9	—	—	—	—	—	—	35	0.15	1.0	—	—	—
	T9325	1.2	160	0.40	1.9	—	—	—	150	0.40	1.9	—	—	—	—	—	—	—	—	—	—	—	—
DNMG 150604E-M	T5315	0.4	200	0.20	1.9	—	—	—	190	0.20	1.9	—	—	—	—	—	—	40	0.15	1.0	—	—	—
	T9315	0.4	190	0.20	1.9	—	—	—	180	0.20	1.9	—	—	—	—	—	—	35	0.15	1.0	—	—	—
	T9325	0.4	170	0.20	1.9	—	—	—	160	0.20	1.9	—	—	—	—	—	—	—	—	—	—	—	—
	T9335	0.4	145	0.20	1.9	—	—	—	—	—	—	—	—	—	—	—	—	—	—	—	—	—	—
DNMG 150608E-M	T5315	0.8	205	0.30	1.9	—	—	—	190	0.30	1.9	—	—	—	—	—	—	40	0.15	1.0	—	—	—
	T9310	0.8	205	0.30	1.9	—	—	—	190	0.30	1.9	—	—	—	—	—	—	40	0.15	1.0	—	—	—
	T9315	0.8	190	0.30	1.9	—	—	—	180	0.30	1.9	—	—	—	—	—	—	35	0.15	1.0	—	—	—
	T9325	0.8	170	0.30	1.9	—	—	—	160	0.30	1.9	—	—	—	—	—	—	—	—	—	—	—	—
	T9335	0.8	145	0.30	1.9	—	—	—	—	—	—	—	—	—	—	—	—	—	—	—	—	—	—
DNMG 150612E-M	T5315	1.2	200	0.40	1.9	—	—	—	190	0.40	1.9	—	—	—	—	—	—	40	0.15	1.0	—	—	—
	T9310	1.2	190	0.40	1.9	—	—	—	180	0.40	1.9	—	—	—	—	—	—	35	0.15	1.0	—	—	—
	T9315	1.2	175	0.40	1.9	—	—	—	165	0.40	1.9	—	—	—	—	—	—	35	0.15	1.0	—	—	—
	T9325	1.2	160	0.40	1.9	—	—	—	150	0.40	1.9	—	—	—	—	—	—	—	—	—	—	—	—
	T9335	1.2	140	0.40	1.9	—	—	—	—	—	—	—	—	—	—	—	—	—	—	—	—	—	—

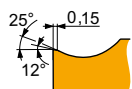

NF geometri, ince finişten orta kabaya kadar işlemek için çok pozitif tasarım, darbesiz kesim için uygun.

DNMG 110404E-NF	T6310	0.4	155	0.15	0.8	110	0.14	0.8	125	0.15	0.8	465	0.18	0.8	45	0.12	0.6	—	—	—	—	—	—
	T7325	0.4	170	0.18	0.8	130	0.16	0.8	—	—	—	—	—	—	55	0.16	0.6	—	—	—	—	—	—
	T7335	0.4	165	0.18	0.8	125	0.16	0.8	—	—	—	—	—	—	50	0.16	0.6	—	—	—	—	—	—
	T8330	0.4	160	0.15	0.8	95	0.14	0.8	150	0.15	0.8	480	0.18	0.8	40	0.12	0.6	—	—	—	—	—	—
	T8430	0.4	190	0.15	0.8	105	0.14	0.8	155	0.15	0.8	525	0.18	0.8	40	0.12	0.6	—	—	—	—	—	—
	T9315	0.4	255	0.15	0.8	—	—	—	240	0.15	0.8	—	—	—	—	—	—	—	—	—	—	—	—
	T9325	0.4	210	0.18	0.8	125	0.16	0.8	195	0.18	0.8	—	—	—	45	0.16	0.6	—	—	—	—	—	—
	T9335	0.4	140	0.18	0.8	—	—	—	—	—	—	—	—	—	—	—	—	—	—	—	—	—	—



Kesme hızı (vc), ilerleme (f) ve kesme derinliği (ap) için uygunluk ve başlangıç değerleri. Daha ileri hesaplamalar için İşleme Hesaplayıcısı uygulamasına başvurun.

Product	RE (mm)	P			M			K			N			S			H		
		vc (m/min)	f (mm/rev)	ap (mm)	vc (m/min)	f (mm/rev)	ap (mm)	vc (m/min)	f (mm/rev)	ap (mm)	vc (m/min)	f (mm/rev)	ap (mm)	vc (m/min)	f (mm/rev)	ap (mm)	vc (m/min)	f (mm/rev)	ap (mm)

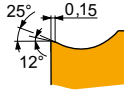

NF geometri, ince finişten orta kabaya kadar işlemek için çok pozitif tasarım, darbesiz kesim için uygun.

DNMG 110408E-NF	T6310	0.8	175	0.17	1.0	125	0.15	1.0	140	0.17	1.0	525	0.20	1.0	50	0.14	0.8	-	-	-
	T7325	0.8	200	0.18	1.0	155	0.16	1.0	-	-	-	-	-	-	65	0.16	0.8	-	-	-
	T7335	0.8	195	0.18	1.0	150	0.16	1.0	-	-	-	-	-	-	60	0.16	0.8	-	-	-
	T8330	0.8	175	0.17	1.0	105	0.15	1.0	165	0.17	1.0	525	0.20	1.0	40	0.14	0.8	-	-	-
	T8430	0.8	205	0.17	1.0	110	0.15	1.0	170	0.17	1.0	570	0.20	1.0	45	0.14	0.8	-	-	-
	T9315	0.8	280	0.17	1.0	-	-	-	265	0.17	1.0	-	-	-	-	-	-	-	-	-
	T9325	0.8	250	0.18	1.0	150	0.16	1.0	235	0.18	1.0	-	-	-	55	0.16	0.8	-	-	-
DNMG 150404E-NF	T6310	0.4	140	0.17	1.7	100	0.15	1.7	110	0.17	1.7	420	0.20	1.7	40	0.15	1.4	-	-	-
	T7325	0.4	160	0.18	1.7	120	0.16	1.7	-	-	-	-	-	50	0.16	1.4	-	-	-	
	T7335	0.4	155	0.18	1.7	120	0.16	1.7	-	-	-	-	-	50	0.16	1.4	-	-	-	
	T8330	0.4	140	0.17	1.7	80	0.15	1.7	130	0.17	1.7	420	0.20	1.7	35	0.15	1.4	-	-	-
	T8430	0.4	165	0.17	1.7	90	0.15	1.7	135	0.17	1.7	450	0.20	1.7	35	0.15	1.4	-	-	-
	T9315	0.4	235	0.15	1.7	-	-	-	220	0.15	1.7	-	-	-	-	-	-	-	-	-
	T9325	0.4	200	0.18	1.7	120	0.16	1.7	190	0.18	1.7	-	-	-	45	0.16	1.4	-	-	-
DNMG 150408E-NF	T6310	0.8	165	0.18	1.7	115	0.16	1.7	130	0.18	1.7	495	0.22	1.7	45	0.16	1.4	-	-	-
	T7325	0.8	190	0.18	1.7	145	0.16	1.7	-	-	-	-	-	60	0.16	1.4	-	-	-	
	T7335	0.8	185	0.18	1.7	140	0.16	1.7	-	-	-	-	-	60	0.16	1.4	-	-	-	
	T8330	0.8	165	0.18	1.7	95	0.16	1.7	155	0.18	1.7	495	0.22	1.7	40	0.16	1.4	-	-	-
	T8430	0.8	190	0.18	1.7	105	0.16	1.7	155	0.18	1.7	525	0.22	1.7	40	0.16	1.4	-	-	-
	T9315	0.8	270	0.17	1.7	-	-	-	255	0.17	1.7	-	-	-	-	-	-	-	-	-
	T9325	0.8	235	0.18	1.7	140	0.16	1.7	220	0.18	1.7	-	-	-	50	0.16	1.4	-	-	-
DNMG 150604E-NF	HF7	0.4	-	-	-	80	0.14	1.9	130	0.15	1.9	420	0.18	1.9	-	-	-	-	-	-
	T6310	0.4	140	0.17	1.9	100	0.15	1.9	110	0.17	1.9	420	0.20	1.9	40	0.15	1.5	-	-	-
	T7325	0.4	155	0.18	1.9	120	0.16	1.9	-	-	-	-	-	50	0.16	1.5	-	-	-	
	T7335	0.4	150	0.18	1.9	115	0.16	1.9	-	-	-	-	-	45	0.16	1.5	-	-	-	
	T8315	0.4	145	0.17	1.9	85	0.15	1.9	135	0.17	1.9	435	0.20	1.9	35	0.15	1.5	-	-	-
	T8330	0.4	140	0.17	1.9	80	0.15	1.9	130	0.17	1.9	420	0.20	1.9	35	0.15	1.5	-	-	-
	T8430	0.4	165	0.17	1.9	90	0.15	1.9	135	0.17	1.9	450	0.20	1.9	35	0.15	1.5	-	-	-
	T9315	0.4	235	0.15	1.9	-	-	-	220	0.15	1.9	-	-	-	-	-	-	-	-	-
	T9325	0.4	195	0.18	1.9	115	0.16	1.9	185	0.18	1.9	-	-	-	40	0.16	1.5	-	-	-
DNMG 150608E-NF	HF7	0.8	-	-	-	90	0.15	1.9	145	0.17	1.9	465	0.20	1.9	-	-	-	-	-	-
	T6310	0.8	165	0.18	1.9	115	0.16	1.9	130	0.18	1.9	495	0.22	1.9	45	0.16	1.5	-	-	-
	T7325	0.8	185	0.18	1.9	140	0.16	1.9	-	-	-	-	-	60	0.16	1.5	-	-	-	
	T7335	0.8	180	0.18	1.9	140	0.16	1.9	-	-	-	-	-	55	0.16	1.5	-	-	-	
	T8315	0.8	175	0.18	1.9	105	0.16	1.9	165	0.18	1.9	525	0.22	1.9	40	0.16	1.5	-	-	-
	T8330	0.8	165	0.18	1.9	95	0.16	1.9	155	0.18	1.9	495	0.22	1.9	40	0.16	1.5	-	-	-
	T8430	0.8	190	0.18	1.9	105	0.16	1.9	155	0.18	1.9	525	0.22	1.9	40	0.16	1.5	-	-	-
	T9315	0.8	265	0.17	1.9	-	-	-	250	0.17	1.9	-	-	-	-	-	-	-	-	-
	T9325	0.8	230	0.18	1.9	135	0.16	1.9	215	0.18	1.9	-	-	-	50	0.16	1.5	-	-	-
DNMG 150612E-NF	T6310	1.2	150	0.30	1.5	105	0.27	1.5	120	0.30	1.5	450	0.36	1.5	45	0.21	1.2	-	-	-
	T8430	1.2	165	0.30	1.5	90	0.27	1.5	135	0.30	1.5	450	0.36	1.5	35	0.21	1.2	-	-	-
	T9325	1.2	200	0.30	1.5	120	0.27	1.5	190	0.30	1.5	-	-	-	45	0.21	1.2	-	-	-

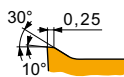

NM geometri, ince finiş, orta ve kaba işlemek için çok pozitif tasarım, darbesiz kesim için uygun.

DNMG 110404E-NM	T7325	0.4	175	0.20	0.8	135	0.18	0.8	-	-	-	-	-	55	0.20	0.6	-	-	-	
	T7335	0.4	165	0.20	0.8	125	0.18	0.8	-	-	-	-	-	50	0.20	0.6	-	-	-	
	T8315	0.4	160	0.20	0.8	95	0.18	0.8	-	-	-	480	0.24	0.8	40	0.20	0.6	-	-	-
	T8330	0.4	150	0.20	0.8	90	0.18	0.8	-	-	-	450	0.24	0.8	35	0.20	0.6	-	-	-
	T8430	0.4	175	0.20	0.8	95	0.18	0.8	-	-	-	480	0.24	0.8	35	0.20	0.6	-	-	-
	T9325	0.4	210	0.20	0.8	125	0.18	0.8	-	-	-	-	-	45	0.20	0.6	-	-	-	



Kesme hızı (vc), ilerleme (f) ve kesme derinliği (ap) için uygunluk ve başlangıç değerleri. Daha ileri hesaplamalar için İşleme Hesaplayıcısı uygulamasına başvurun.

Product	RE (mm)	P			M			K			N			S			H		
		vc (m/min)	f (mm/rev)	ap (mm)	vc (m/min)	f (mm/rev)	ap (mm)	vc (m/min)	f (mm/rev)	ap (mm)	vc (m/min)	f (mm/rev)	ap (mm)	vc (m/min)	f (mm/rev)	ap (mm)	vc (m/min)	f (mm/rev)	ap (mm)

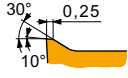

NM geometri, ince finiş, orta ve kaba işlemek için çok pozitif tasarım, darbesiz kesim için uygun.

DNMG 110408E-NM	T7325	0.8	✓	190	0.25	0.8	■	145	0.23	0.8	—	—	—	■	60	0.20	0.6	—	—	—	
	T7335	0.8	✓	185	0.25	0.8	■	140	0.23	0.8	—	—	—	■	60	0.20	0.6	—	—	—	
	T8315	0.8	✓	180	0.25	0.8	■	105	0.23	0.8	—	—	—	✓	540	0.30	0.8	✓	45	0.20	0.6
	T8330	0.8	■	170	0.25	0.8	■	100	0.23	0.8	—	—	—	✓	510	0.30	0.8	✓	40	0.20	0.6
	T8430	0.8	■	190	0.25	0.8	■	105	0.23	0.8	—	—	—	✓	525	0.30	0.8	✓	40	0.20	0.6
DNMG 150408E-NM	T9325	0.8	■	230	0.25	0.8	■	135	0.23	0.8	—	—	—	—	—	—	—	—	—	—	
	T7335	0.8	✓	170	0.25	1.9	■	130	0.23	1.9	—	—	—	■	55	0.20	1.5	—	—	—	
	T8330	0.8	■	155	0.25	1.9	■	90	0.23	1.9	—	—	—	✓	465	0.30	1.9	✓	35	0.20	1.5
	T8430	0.8	■	175	0.25	1.9	■	95	0.23	1.9	—	—	—	✓	480	0.30	1.9	✓	35	0.20	1.5
DNMG 150604E-NM	T9325	0.8	■	210	0.25	1.9	■	125	0.23	1.9	—	—	—	—	—	—	—	—	—	—	
	T7325	0.4	✓	160	0.20	1.9	■	120	0.18	1.9	—	—	—	■	50	0.20	1.5	—	—	—	
	T7335	0.4	✓	150	0.20	1.9	■	115	0.18	1.9	—	—	—	■	45	0.20	1.5	—	—	—	
	T8315	0.4	✓	150	0.20	1.9	■	90	0.18	1.9	—	—	—	✓	450	0.24	1.9	✓	35	0.20	1.5
	T8330	0.4	■	135	0.20	1.9	■	80	0.18	1.9	—	—	—	✓	405	0.24	1.9	✓	30	0.20	1.5
	T8430	0.4	■	155	0.20	1.9	■	85	0.18	1.9	—	—	—	✓	435	0.24	1.9	✓	30	0.20	1.5
DNMG 150608E-NM	T9315	0.4	■	220	0.20	1.9	■	—	—	—	—	—	—	—	—	—	—	—	—	—	
	T9325	0.4	■	195	0.20	1.9	■	115	0.18	1.9	—	—	—	—	—	—	—	—	—	—	
	T7325	0.8	✓	175	0.25	1.9	■	135	0.23	1.9	—	—	—	■	55	0.20	1.5	—	—	—	
	T7335	0.8	✓	170	0.25	1.9	■	130	0.23	1.9	—	—	—	■	55	0.20	1.5	—	—	—	
	T8315	0.8	✓	165	0.25	1.9	■	95	0.23	1.9	—	—	—	✓	495	0.30	1.9	✓	40	0.20	1.5
	T8330	0.8	■	155	0.25	1.9	■	90	0.23	1.9	—	—	—	✓	465	0.30	1.9	✓	35	0.20	1.5
DNMG 150612E-NM	T8430	0.8	■	175	0.25	1.9	■	95	0.23	1.9	—	—	—	✓	480	0.30	1.9	✓	35	0.20	1.5
	T9315	0.8	■	235	0.25	1.9	■	—	—	—	—	—	—	—	—	—	—	—	—	—	
	T9325	0.8	■	210	0.25	1.9	■	125	0.23	1.9	—	—	—	—	—	—	—	—	—	—	
	T7325	1.2	✓	175	0.30	1.9	■	135	0.27	1.9	—	—	—	■	55	0.24	1.5	—	—	—	
	T7335	1.2	✓	170	0.30	1.9	■	130	0.27	1.9	—	—	—	■	55	0.24	1.5	—	—	—	

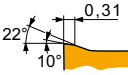

NMR geometri, ortadan kabaya kadar işlemek için pozitif tasarım, darbesiz kesim için uygun.

DNMG 110404E-NMR	T7325	0.4	✓	150	0.20	0.8	■	115	0.18	0.8	—	—	—	■	45	0.18	0.6	—	—	—
	T9315	0.4	■	205	0.20	0.8	■	—	—	—	—	—	—	—	—	—	—	—	—	—
	T9325	0.4	■	185	0.20	0.8	■	110	0.18	0.8	—	—	—	—	—	—	—	—	—	—
DNMG 110408E-NMR	T7325	0.8	✓	155	0.30	0.8	■	120	0.27	0.8	—	—	—	■	50	0.24	0.6	—	—	—
	T9315	0.8	■	205	0.30	0.8	■	—	—	—	—	—	—	—	—	—	—	—	—	—
	T9325	0.8	■	185	0.30	0.8	■	110	0.27	0.8	—	—	—	—	—	—	—	—	—	—
DNMG 110412E-NMR	T7325	1.2	✓	155	0.30	1.6	■	120	0.27	1.6	—	—	—	■	50	0.24	1.3	—	—	—
	T9315	1.2	■	200	0.30	1.6	■	—	—	—	—	—	—	—	—	—	—	—	—	—
	T9325	1.2	■	180	0.30	1.6	■	105	0.27	1.6	—	—	—	—	—	—	—	—	—	—
DNMG 150404E-NMR	T7325	0.4	✓	140	0.20	1.9	■	105	0.18	1.9	—	—	—	■	45	0.18	1.5	—	—	—
	T7335	0.4	✓	130	0.20	1.9	■	100	0.18	1.9	—	—	—	■	40	0.18	1.5	—	—	—
	T9325	0.4	■	170	0.20	1.9	■	100	0.18	1.9	—	—	—	—	—	—	—	—	—	—
DNMG 150408E-NMR	T7325	0.8	✓	145	0.30	1.9	■	110	0.27	1.9	—	—	—	■	45	0.24	1.5	—	—	—
	T7335	0.8	✓	140	0.30	1.9	■	105	0.27	1.9	—	—	—	■	45	0.24	1.5	—	—	—
	T8330	0.8	■	125	0.30	1.9	■	75	0.27	1.9	—	—	—	—	—	—	—	—	—	—
	T8430	0.8	■	135	0.30	1.9	■	75	0.27	1.9	—	—	—	—	—	—	—	—	—	—
	T9315	0.8	■	190	0.30	1.9	■	—	—	—	—	—	—	—	—	—	—	—	—	—
	T9325	0.8	■	170	0.30	1.9	■	100	0.27	1.9	—	—	—	—	—	—	—	—	—	—
DNMG 150604E-NMR	T7325	0.4	✓	140	0.20	1.9	■	105	0.18	1.9	—	—	—	■	45	0.18	1.5	—	—	—
	T7335	0.4	✓	130	0.20	1.9	■	100	0.18	1.9	—	—	—	■	40	0.18	1.5	—	—	—
	T8330	0.4	■	120	0.20	1.9	■	70	0.18	1.9	—	—	—	—	—	—	—	—	—	—
	T8430	0.4	■	135	0.20	1.9	■	75	0.18	1.9	—	—	—	—	—	—	—	—	—	—
	T9315	0.4	■	190	0.20	1.9	■	—	—	—	—	—	—	—	—	—	—	—	—	—
	T9325	0.4	■	170	0.20	1.9	■	100	0.18	1.9	—	—	—	—	—	—	—	—	—	—



Kesme hızı (vc), ilerleme (f) ve kesme derinliği (ap) için uygunluk ve başlangıç değerleri. Daha ileri hesaplamalar için İşleme Hesaplayıcısı uygulamasına başvurun.

Product	RE (mm)	P			M			K			N			S			H		
		vc (m/min)	f (mm/rev)	ap (mm)	vc (m/min)	f (mm/rev)	ap (mm)	vc (m/min)	f (mm/rev)	ap (mm)	vc (m/min)	f (mm/rev)	ap (mm)	vc (m/min)	f (mm/rev)	ap (mm)	vc (m/min)	f (mm/rev)	ap (mm)

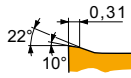

NMR geometri, ortadan kabaya kadar işlemek için pozitif tasarım, darbesiz kesim için uygun.

DNMG 150608E-NMR	T6310	0.8	█	125	0.30	1.9	█	90	0.27	1.9	█	-	-	-	█	35	0.24	1.5	-	-	-
	T7325	0.8	█	145	0.30	1.9	█	110	0.27	1.9	█	-	-	-	█	45	0.24	1.5	-	-	-
	T7335	0.8	█	140	0.30	1.9	█	105	0.27	1.9	█	-	-	-	█	45	0.24	1.5	-	-	-
	T8330	0.8	█	125	0.30	1.9	█	75	0.27	1.9	█	-	-	-	█	30	0.24	1.5	-	-	-
	T8430	0.8	█	135	0.30	1.9	█	75	0.27	1.9	█	-	-	-	█	25	0.24	1.5	-	-	-
	T9315	0.8	█	190	0.30	1.9	█	-	-	-	█	-	-	-	-	-	-	-	-	-	-
DNMG 150612E-NMR	T9325	0.8	█	170	0.30	1.9	█	100	0.27	1.9	█	-	-	-	█	35	0.24	1.5	-	-	-
	T7325	1.2	█	155	0.30	1.9	█	120	0.27	1.9	█	-	-	-	█	50	0.24	1.5	-	-	-
	T7335	1.2	█	145	0.30	1.9	█	110	0.27	1.9	█	-	-	-	█	45	0.24	1.5	-	-	-
	T8330	1.2	█	135	0.30	1.9	█	80	0.27	1.9	█	-	-	-	█	30	0.24	1.5	-	-	-
	T8430	1.2	█	145	0.30	1.9	█	80	0.27	1.9	█	-	-	-	█	30	0.24	1.5	-	-	-
	T9315	1.2	█	200	0.30	1.9	█	-	-	-	█	-	-	-	-	-	-	-	-	-	-
T9325	1.2	█	180	0.30	1.9	█	105	0.27	1.9	█	-	-	-	█	40	0.24	1.5	-	-	-	

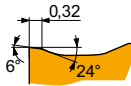

NRM geometri, orta kabadan kabaya kadar işlemek için pozitif tasarım, darbesizden darbeli kesime kadar uygun.

DNMG 150408-NRM	T7325	0.8	█	140	0.30	3.0	█	105	0.27	3.0	█	-	-	-	█	45	0.24	2.4	-	-	-
	T7335	0.8	█	130	0.30	3.0	█	100	0.27	3.0	█	-	-	-	█	40	0.24	2.4	-	-	-
	T9315	0.8	█	180	0.30	3.0	█	-	-	-	█	-	-	-	-	-	-	-	-	-	-
DNMG 150604-NRM	T7325	0.4	█	130	0.20	3.0	█	100	0.18	3.0	█	-	-	-	█	40	0.20	2.4	-	-	-
	T7335	0.4	█	130	0.20	3.0	█	100	0.18	3.0	█	-	-	-	█	40	0.20	2.4	-	-	-
	T9315	0.4	█	180	0.20	3.0	█	-	-	-	█	-	-	-	-	-	-	-	-	-	-
DNMG 150608-NRM	T7325	0.8	█	140	0.30	3.0	█	105	0.27	3.0	█	-	-	-	█	45	0.24	2.4	-	-	-
	T7335	0.8	█	130	0.30	3.0	█	100	0.27	3.0	█	-	-	-	█	40	0.24	2.4	-	-	-
	T9315	0.8	█	180	0.30	3.0	█	-	-	-	█	-	-	-	-	-	-	-	-	-	-
DNMG 150612-NRM	T7325	1.2	█	145	0.30	3.0	█	110	0.27	3.0	█	-	-	-	█	45	0.27	2.4	-	-	-
	T7335	1.2	█	140	0.30	3.0	█	105	0.27	3.0	█	-	-	-	█	45	0.27	2.4	-	-	-
	T9315	1.2	█	190	0.30	3.0	█	-	-	-	█	-	-	-	-	-	-	-	-	-	-

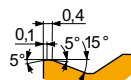

R geometri, orta kabadan kaba işlemeye kadar, darbesizden darbeli kesime kadar uygun.

DNMG 150408E-R	T5315	0.8	█	175	0.40	3.0	█	-	-	-	█	165	0.40	3.0	█	-	-	-	█	35	0.15	1.0
DNMG 150608E-R	T5305	0.8	█	200	0.40	3.0	█	-	-	-	█	190	0.40	3.0	█	-	-	-	█	40	0.15	1.0
	T5315	0.8	█	175	0.40	3.0	█	-	-	-	█	165	0.40	3.0	█	-	-	-	█	35	0.15	1.0
	T9310	0.8	█	170	0.40	3.0	█	-	-	-	█	160	0.40	3.0	█	-	-	-	█	30	0.15	1.0
	T9315	0.8	█	155	0.40	3.0	█	-	-	-	█	145	0.40	3.0	█	-	-	-	█	30	0.15	1.0
	T9325	0.8	█	140	0.40	3.0	█	-	-	-	█	130	0.40	3.0	█	-	-	-	█	-	-	-
	T9310	0.8	█	180	0.40	3.0	█	-	-	-	█	170	0.40	3.0	█	-	-	-	█	-	-	-
DNMG 150612E-R	T5305	1.2	█	210	0.40	3.0	█	-	-	-	█	195	0.40	3.0	█	-	-	-	█	40	0.15	1.0
	T5315	1.2	█	185	0.40	3.0	█	-	-	-	█	175	0.40	3.0	█	-	-	-	█	35	0.15	1.0
	T9310	1.2	█	180	0.40	3.0	█	-	-	-	█	170	0.40	3.0	█	-	-	-	█	35	0.15	1.0
	T9315	1.2	█	165	0.40	3.0	█	-	-	-	█	155	0.40	3.0	█	-	-	-	█	30	0.15	1.0
	T9325	1.2	█	150	0.40	3.0	█	-	-	-	█	140	0.40	3.0	█	-	-	-	█	-	-	-
DNMG 150616E-R	T9325	1.6	█	155	0.40	3.0	█	-	-	-	█	145	0.40	3.0	█	-	-	-	█	-	-	-

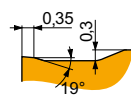

RM geometri, yarı kabadan kaba işlemeye kadar, ve darbesizden darbeli kesime kadar uygun.

DNMG 110408E-RM	T9315	0.8	█	190	0.40	2.0	█	-	-	-	█	180	0.40	2.0	█	-	-	-	█	-	-	-
	T9325	0.8	█	170	0.40	2.0	█	100	0.36	2.0	█	160	0.40	2.0	█	-	-	-	█	-	-	-
	T9335	0.8	█	145	0.40	2.0	█	85	0.36	2.0	█	-	-	-	█	-	-	-	█	-	-	-
DNMG 110412E-RM	T9315	1.2	█	230	0.30	2.0	█	-	-	-	█	215	0.30	2.0	█	-	-	-	█	-	-	-
	T9325	1.2	█	205	0.30	2.0	█	120	0.27	2.0	█	190	0.30	2.0	█	-	-	-	█	-	-	-



Kesme hızı (vc), ilerleme (f) ve kesme derinliği (ap) için uygunluk ve başlangıç değerleri. Daha ileri hesaplamalar için İşleme Hesaplayıcısı uygulamasına başvurun.

Product	RE  (mm)	P			M			K			N			S			H		
		vc (m/min)	f (mm/rev)	ap (mm)	vc (m/min)	f (mm/rev)	ap (mm)	vc (m/min)	f (mm/rev)	ap (mm)	vc (m/min)	f (mm/rev)	ap (mm)	vc (m/min)	f (mm/rev)	ap (mm)	vc (m/min)	f (mm/rev)	ap (mm)

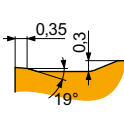

RM geometri, yarı kabadan kaba işleme kadar, ve darbesizden darbeli kesime kadar uygun.

DNMG 150408E-RM	T9315	0.8	180	0.40	3.0	—	—	—	170	0.40	3.0	—	—	—	—	—	—	—	—
	T9325	0.8	165	0.40	3.0	95	0.36	3.0	155	0.40	3.0	—	—	—	—	—	—	—	—
	T9335	0.8	140	0.40	3.0	80	0.36	3.0	—	—	—	—	—	—	—	—	—	—	—
DNMG 150412E-RM	T7325	1.2	155	0.40	3.0	120	0.36	3.0	—	—	—	—	—	—	—	—	—	—	—
	T9315	1.2	190	0.40	3.0	—	—	—	180	0.40	3.0	—	—	—	—	—	—	—	—
	T9325	1.2	170	0.40	3.0	100	0.36	3.0	160	0.40	3.0	—	—	—	—	—	—	—	—
DNMG 150608E-RM	T5305	0.8	230	0.40	3.0	—	—	—	215	0.40	3.0	—	—	—	—	—	—	—	—
	T5315	0.8	205	0.40	3.0	—	—	—	190	0.40	3.0	—	—	—	—	—	—	—	—
	T7325	0.8	145	0.40	3.0	110	0.36	3.0	—	—	—	—	—	—	—	—	—	—	—
	T7335	0.8	135	0.40	3.0	105	0.36	3.0	—	—	—	—	—	—	—	—	—	—	—
	T8315	0.8	135	0.40	3.0	80	0.36	3.0	125	0.40	3.0	—	—	—	—	—	—	—	—
	T8330	0.8	130	0.40	3.0	75	0.36	3.0	120	0.40	3.0	—	—	—	—	—	—	—	—
	T8430	0.8	135	0.40	3.0	75	0.36	3.0	110	0.40	3.0	—	—	—	—	—	—	—	—
	T9310	0.8	200	0.40	3.0	—	—	—	190	0.40	3.0	—	—	—	—	—	—	—	—
	T9315	0.8	180	0.40	3.0	—	—	—	170	0.40	3.0	—	—	—	—	—	—	—	—
	T9325	0.8	165	0.40	3.0	95	0.36	3.0	155	0.40	3.0	—	—	—	—	—	—	—	—
	T9335	0.8	140	0.40	3.0	80	0.36	3.0	—	—	—	—	—	—	—	—	—	—	—
	DNMG 150612E-RM	T5305	1.2	240	0.40	3.0	—	—	—	225	0.40	3.0	—	—	—	—	—	—	—
T5315		1.2	215	0.40	3.0	—	—	—	200	0.40	3.0	—	—	—	—	—	—	—	—
T7325		1.2	155	0.40	3.0	120	0.36	3.0	—	—	—	—	—	—	—	—	—	—	—
T7335		1.2	145	0.40	3.0	110	0.36	3.0	—	—	—	—	—	—	—	—	—	—	—
T8330		1.2	135	0.40	3.0	80	0.36	3.0	125	0.40	3.0	—	—	—	—	—	—	—	—
T8430		1.2	140	0.40	3.0	75	0.36	3.0	115	0.40	3.0	—	—	—	—	—	—	—	—
T9310		1.2	210	0.40	3.0	—	—	—	195	0.40	3.0	—	—	—	—	—	—	—	—
T9315		1.2	190	0.40	3.0	—	—	—	180	0.40	3.0	—	—	—	—	—	—	—	—
T9325		1.2	170	0.40	3.0	100	0.36	3.0	160	0.40	3.0	—	—	—	—	—	—	—	—
T9335		1.2	150	0.40	3.0	90	0.36	3.0	—	—	—	—	—	—	—	—	—	—	—
DNMG 150616E-RM	T5315	1.6	225	0.40	3.0	—	—	—	210	0.40	3.0	—	—	—	—	—	—	—	—
	T9315	1.6	200	0.40	3.0	—	—	—	190	0.40	3.0	—	—	—	—	—	—	—	—
	T9325	1.6	180	0.40	3.0	105	0.36	3.0	170	0.40	3.0	—	—	—	—	—	—	—	—
	T9335	1.6	155	0.40	3.0	90	0.36	3.0	—	—	—	—	—	—	—	—	—	—	—

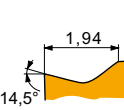

SF geometri, ince finiş ve ince cidar işlemek için pozitif tasarım, darbesiz kesim için uygun.

DNMG 110404E-SF	T6310	0.4	150	0.15	0.8	105	0.14	0.8	120	0.15	0.8	450	0.18	0.8	45	0.12	0.6	30	0.15	1.0
	T7325	0.4	165	0.17	0.8	125	0.15	0.8	—	—	—	—	—	—	50	0.15	0.6	—	—	—
	T8315	0.4	160	0.15	0.8	95	0.14	0.8	150	0.15	0.8	480	0.18	0.8	40	0.12	0.6	30	0.15	1.0
	T8430	0.4	180	0.15	0.8	95	0.14	0.8	145	0.15	0.8	495	0.18	0.8	35	0.12	0.6	30	0.15	1.0
	T9315	0.4	245	0.15	0.8	—	—	—	230	0.15	0.8	—	—	—	—	—	—	45	0.15	1.0
DNMG 110408E-SF	T9325	0.4	210	0.17	0.8	125	0.15	0.8	195	0.17	0.8	—	—	—	45	0.15	0.6	—	—	—
	T6310	0.8	175	0.17	0.8	125	0.15	0.8	140	0.17	0.8	525	0.20	0.8	50	0.14	0.6	35	0.15	1.0
	T7325	0.8	195	0.17	0.8	150	0.15	0.8	—	—	—	—	—	—	60	0.15	0.6	—	—	—
	T7335	0.8	195	0.17	0.8	150	0.15	0.8	—	—	—	—	—	—	60	0.15	0.6	—	—	—
	T8315	0.8	180	0.17	0.8	105	0.15	0.8	170	0.17	0.8	540	0.20	0.8	45	0.14	0.6	35	0.15	1.0
	T8430	0.8	200	0.17	0.8	110	0.15	0.8	165	0.17	0.8	555	0.20	0.8	40	0.14	0.6	35	0.15	1.0
	T9325	0.8	250	0.17	0.8	150	0.15	0.8	235	0.17	0.8	—	—	—	55	0.15	0.6	—	—	—
DNMG 150404E-SF	T6310	0.4	140	0.15	1.5	100	0.14	1.5	110	0.15	1.5	420	0.18	1.5	40	0.12	1.2	25	0.15	1.0
	T8315	0.4	150	0.15	1.5	90	0.14	1.5	140	0.15	1.5	450	0.18	1.5	35	0.12	1.2	30	0.15	1.0
	T8430	0.4	165	0.15	1.5	90	0.14	1.5	135	0.15	1.5	450	0.18	1.5	35	0.12	1.2	25	0.15	1.0
	T9325	0.4	195	0.17	1.5	115	0.15	1.5	185	0.17	1.5	—	—	—	40	0.15	1.2	—	—	—



Kesme hızı (vc), ilerleme (f) ve kesme derinliği (ap) için uygunluk ve başlangıç değerleri. Daha ileri hesaplamalar için İşleme Hesaplayıcısı uygulamasına başvurun.

Product	RE (mm)	P			M			K			N			S			H		
		vc (m/min)	f (mm/rev)	ap (mm)	vc (m/min)	f (mm/rev)	ap (mm)	vc (m/min)	f (mm/rev)	ap (mm)	vc (m/min)	f (mm/rev)	ap (mm)	vc (m/min)	f (mm/rev)	ap (mm)	vc (m/min)	f (mm/rev)	ap (mm)

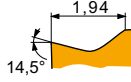

SF geometri, ince finiş ve ince cidar işlemek için pozitif tasarım, darbesiz kesim için uygun.

DNMG 150408E-SF	T6310	0.8	160	0.17	1.5	115	0.15	1.5	125	0.17	1.5	480	0.20	1.5	45	0.14	1.2	30	0.15	1.0
	T8315	0.8	170	0.17	1.5	100	0.15	1.5	160	0.17	1.5	510	0.20	1.5	40	0.14	1.2	30	0.15	1.0
	T8330	0.8	160	0.17	1.5	95	0.15	1.5	150	0.17	1.5	480	0.20	1.5	40	0.14	1.2	30	0.15	1.0
	T8430	0.8	190	0.17	1.5	105	0.15	1.5	155	0.17	1.5	525	0.20	1.5	40	0.14	1.2	30	0.15	1.0
	T9325	0.8	235	0.17	1.5	140	0.15	1.5	220	0.17	1.5	-	-	-	50	0.15	1.2	-	-	-
DNMG 150604E-SF	H07	0.4	-	-	-	70	0.14	1.5	115	0.15	1.5	360	0.18	1.5	35	0.12	1.2	-	-	-
	T6310	0.4	140	0.15	1.5	100	0.14	1.5	110	0.15	1.5	420	0.18	1.5	40	0.12	1.2	25	0.15	1.0
	T7325	0.4	155	0.17	1.5	120	0.15	1.5	-	-	-	-	-	50	0.15	1.2	-	-	-	
	T7335	0.4	150	0.17	1.5	115	0.15	1.5	-	-	-	-	-	45	0.15	1.2	-	-	-	
	T8315	0.4	150	0.15	1.5	90	0.14	1.5	140	0.15	1.5	450	0.18	1.5	35	0.12	1.2	30	0.15	1.0
	T8330	0.4	140	0.15	1.5	80	0.14	1.5	130	0.15	1.5	420	0.18	1.5	35	0.12	1.2	25	0.15	1.0
	T8430	0.4	165	0.15	1.5	90	0.14	1.5	135	0.15	1.5	450	0.18	1.5	35	0.12	1.2	25	0.15	1.0
	T9315	0.4	230	0.15	1.5	-	-	-	215	0.15	1.5	-	-	-	-	-	-	45	0.15	1.0
	T9325	0.4	195	0.17	1.5	115	0.15	1.5	185	0.17	1.5	-	-	-	40	0.15	1.2	-	-	-
DNMG 150608E-SF	H07	0.8	-	-	-	80	0.15	1.5	130	0.17	1.5	415	0.20	1.5	40	0.14	1.2	-	-	-
	T6310	0.8	160	0.17	1.5	115	0.15	1.5	125	0.17	1.5	480	0.20	1.5	45	0.14	1.2	30	0.15	1.0
	T7325	0.8	185	0.17	1.5	140	0.15	1.5	-	-	-	-	-	60	0.15	1.2	-	-	-	
	T7335	0.8	180	0.17	1.5	140	0.15	1.5	-	-	-	-	-	55	0.15	1.2	-	-	-	
	T8315	0.8	170	0.17	1.5	100	0.15	1.5	160	0.17	1.5	510	0.20	1.5	40	0.14	1.2	30	0.15	1.0
	T8330	0.8	160	0.17	1.5	95	0.15	1.5	150	0.17	1.5	480	0.20	1.5	40	0.14	1.2	30	0.15	1.0
	T8430	0.8	190	0.17	1.5	105	0.15	1.5	155	0.17	1.5	525	0.20	1.5	40	0.14	1.2	30	0.15	1.0
	T9315	0.8	255	0.17	1.5	-	-	-	240	0.17	1.5	-	-	-	-	-	-	50	0.15	1.0
	T9325	0.8	235	0.17	1.5	140	0.15	1.5	220	0.17	1.5	-	-	-	50	0.15	1.2	-	-	-
DNMG 150612E-SF	T6310	1.2	145	0.30	1.5	100	0.27	1.5	115	0.30	1.5	435	0.36	1.5	40	0.21	1.2	25	0.15	1.0
	T7325	1.2	165	0.30	1.5	125	0.27	1.5	-	-	-	-	-	50	0.21	1.2	-	-	-	
	T9315	1.2	210	0.30	1.5	-	-	-	195	0.30	1.5	-	-	-	-	-	-	40	0.15	1.0

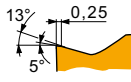

SM geometri, orta işleme için pozitif tasarım, darbesizden darbeli kesime kadar uygun.

DNMG 110404E-SM	T6310	0.4	140	0.20	0.8	100	0.18	0.8	110	0.20	0.8	420	0.24	0.8	40	0.20	0.6	25	0.15	1.0
	T7325	0.4	160	0.20	0.8	120	0.18	0.8	-	-	-	-	-	50	0.20	0.6	-	-	-	
	T7335	0.4	150	0.20	0.8	115	0.18	0.8	-	-	-	-	-	45	0.20	0.6	-	-	-	
	T8430	0.4	155	0.20	0.8	85	0.18	0.8	130	0.20	0.8	435	0.24	0.8	30	0.20	0.6	25	0.15	1.0
	T9325	0.4	190	0.20	0.8	110	0.18	0.8	180	0.20	0.8	-	-	-	40	0.20	0.6	-	-	-
DNMG 110408E-SM	T6310	0.8	150	0.25	1.2	105	0.23	1.2	120	0.25	1.2	450	0.30	1.2	45	0.20	1.0	30	0.15	1.0
	T7325	0.8	170	0.25	1.2	130	0.23	1.2	-	-	-	-	-	55	0.20	1.0	-	-	-	
	T7335	0.8	160	0.25	1.2	120	0.23	1.2	-	-	-	-	-	50	0.20	1.0	-	-	-	
	T8330	0.8	150	0.25	1.2	90	0.23	1.2	140	0.25	1.2	450	0.30	1.2	35	0.20	1.0	30	0.15	1.0
	T8430	0.8	170	0.25	1.2	90	0.23	1.2	135	0.25	1.2	465	0.30	1.2	35	0.20	1.0	25	0.15	1.0
	T9325	0.8	200	0.25	1.2	120	0.23	1.2	190	0.25	1.2	-	-	-	45	0.20	1.0	-	-	-
DNMG 150404E-SM	T6310	0.4	125	0.22	1.7	90	0.20	1.7	100	0.22	1.7	375	0.26	1.7	35	0.20	1.4	25	0.15	1.0
DNMG 150408E-SM	T6310	0.8	140	0.25	2.1	100	0.23	2.1	110	0.25	2.1	420	0.30	2.1	40	0.20	1.7	25	0.15	1.0
DNMG 150604E-SM	T6310	0.4	125	0.22	1.7	90	0.20	1.7	100	0.22	1.7	375	0.26	1.7	35	0.20	1.4	25	0.15	1.0
	T7325	0.4	140	0.22	1.7	105	0.20	1.7	-	-	-	-	-	45	0.20	1.4	-	-	-	
	T7335	0.4	140	0.22	1.7	105	0.20	1.7	-	-	-	-	-	45	0.20	1.4	-	-	-	
	T8330	0.4	125	0.22	1.7	75	0.20	1.7	115	0.22	1.7	375	0.26	1.7	30	0.20	1.4	25	0.15	1.0
	T8430	0.4	140	0.22	1.7	75	0.20	1.7	115	0.22	1.7	390	0.26	1.7	30	0.20	1.4	20	0.15	1.0
	T9315	0.4	200	0.20	1.7	-	-	-	190	0.20	1.7	-	-	-	-	-	-	40	0.15	1.0
	T9325	0.4	170	0.22	1.7	100	0.20	1.7	160	0.22	1.7	-	-	-	35	0.20	1.4	-	-	-



Kesme hızı (vc), ilerleme (f) ve kesme derinliği (ap) için uygunluk ve başlangıç değerleri. Daha ileri hesaplamalar için İşleme Hesaplayıcısı uygulamasına başvurun.

Product	RE  (mm)	P			M			K			N			S			H		
		vc (m/min)	f (mm/rev)	ap (mm)	vc (m/min)	f (mm/rev)	ap (mm)	vc (m/min)	f (mm/rev)	ap (mm)	vc (m/min)	f (mm/rev)	ap (mm)	vc (m/min)	f (mm/rev)	ap (mm)	vc (m/min)	f (mm/rev)	ap (mm)

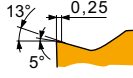

SM geometri, orta işleme için pozitif tasarım, darbesizden darbeli kesime kadar uygun.

DNMG 150608E-SM	T6310	0.8	140	0.25	1.7	100	0.23	1.7	110	0.25	1.7	420	0.30	1.7	40	0.20	1.4	25	0.15	1.0
	T7325	0.8	160	0.25	1.7	120	0.23	1.7	-	-	-	-	-	-	50	0.20	1.4	-	-	-
	T7335	0.8	155	0.25	1.7	120	0.23	1.7	-	-	-	-	-	-	50	0.20	1.4	-	-	-
	T8330	0.8	140	0.25	1.7	80	0.23	1.7	130	0.25	1.7	420	0.30	1.7	35	0.20	1.4	25	0.15	1.0
	T8430	0.8	155	0.25	1.7	85	0.23	1.7	130	0.25	1.7	435	0.30	1.7	30	0.20	1.4	25	0.15	1.0
	T9315	0.8	215	0.25	1.7	-	-	-	200	0.25	1.7	-	-	-	-	-	-	40	0.15	1.0
DNMG 150612E-SM	T6310	1.2	145	0.30	1.7	100	0.27	1.7	115	0.30	1.7	435	0.36	1.7	40	0.24	1.4	25	0.15	1.0
	T7325	1.2	160	0.30	1.7	120	0.27	1.7	-	-	-	-	-	-	50	0.24	1.4	-	-	-
	T7335	1.2	155	0.30	1.7	120	0.27	1.7	-	-	-	-	-	-	50	0.24	1.4	-	-	-
	T8330	1.2	145	0.30	1.7	85	0.27	1.7	135	0.30	1.7	435	0.36	1.7	35	0.24	1.4	25	0.15	1.0
	T8430	1.2	155	0.30	1.7	85	0.27	1.7	130	0.30	1.7	435	0.36	1.7	30	0.24	1.4	25	0.15	1.0
	T9315	1.2	210	0.30	1.7	-	-	-	195	0.30	1.7	-	-	-	-	-	-	40	0.15	1.0
T9325	1.2	190	0.30	1.7	110	0.27	1.7	180	0.30	1.7	-	-	-	40	0.24	1.4	-	-	-	

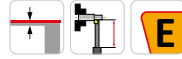
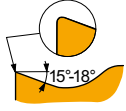

ER-SI geometri, çok pozitif sağ kesme yönlü tasarım, ince finişten yarı kaba işleme kadar, ve darbesiz kesim için uygun.

DNMG 110404ER-SI	T7325	0.4	185	0.20	1.0	140	0.18	1.0	-	-	-	-	-	60	0.18	0.8	-	-	-	
	T7335	0.4	180	0.20	1.0	140	0.18	1.0	-	-	-	-	-	55	0.18	0.8	-	-	-	
	T8330	0.4	160	0.20	1.0	95	0.18	1.0	-	-	-	480	0.24	1.0	40	0.18	0.8	-	-	-
	T8430	0.4	185	0.20	1.0	100	0.18	1.0	-	-	-	510	0.24	1.0	40	0.18	0.8	-	-	-
	T9325	0.4	225	0.20	1.0	135	0.18	1.0	-	-	-	-	-	-	50	0.18	0.8	-	-	-
DNMG 110408ER-SI	T7335	0.8	175	0.35	1.0	135	0.32	1.0	-	-	-	-	-	55	0.25	0.8	-	-	-	
	T8330	0.8	165	0.35	1.0	95	0.32	1.0	-	-	-	495	0.42	1.0	40	0.25	0.8	-	-	-
	T8430	0.8	180	0.35	1.0	95	0.32	1.0	-	-	-	495	0.42	1.0	35	0.25	0.8	-	-	-
	T9325	0.8	210	0.35	1.0	125	0.32	1.0	-	-	-	-	-	45	0.25	0.8	-	-	-	
DNMG 150404ER-SI	T8330	0.4	155	0.20	1.5	90	0.18	1.5	-	-	-	465	0.24	1.5	35	0.18	1.2	-	-	-
	T8430	0.4	175	0.20	1.5	95	0.18	1.5	-	-	-	480	0.24	1.5	35	0.18	1.2	-	-	-
	T9325	0.4	220	0.20	1.5	130	0.18	1.5	-	-	-	-	-	45	0.18	1.2	-	-	-	
DNMG 150408ER-SI	T8330	0.8	160	0.35	1.5	95	0.32	1.5	-	-	-	480	0.42	1.5	40	0.25	1.2	-	-	-
	T8430	0.8	170	0.35	1.5	90	0.32	1.5	-	-	-	465	0.42	1.5	35	0.25	1.2	-	-	-
	T9325	0.8	200	0.35	1.5	120	0.32	1.5	-	-	-	-	-	45	0.25	1.2	-	-	-	
DNMG 150604ER-SI	T7325	0.4	180	0.20	1.5	140	0.18	1.5	-	-	-	-	-	55	0.18	1.2	-	-	-	
	T7335	0.4	170	0.20	1.5	130	0.18	1.5	-	-	-	-	-	55	0.18	1.2	-	-	-	
	T8315	0.4	165	0.20	1.5	95	0.18	1.5	-	-	-	495	0.24	1.5	40	0.18	1.2	-	-	-
	T8330	0.4	155	0.20	1.5	90	0.18	1.5	-	-	-	465	0.24	1.5	35	0.18	1.2	-	-	-
	T8430	0.4	175	0.20	1.5	95	0.18	1.5	-	-	-	480	0.24	1.5	35	0.18	1.2	-	-	-
	T9325	0.4	220	0.20	1.5	130	0.18	1.5	-	-	-	-	-	45	0.18	1.2	-	-	-	
DNMG 150608ER-SI	T7325	0.8	180	0.35	1.5	140	0.32	1.5	-	-	-	-	-	55	0.25	1.2	-	-	-	
	T7335	0.8	170	0.35	1.5	130	0.32	1.5	-	-	-	-	-	55	0.25	1.2	-	-	-	
	T8315	0.8	165	0.35	1.5	95	0.32	1.5	-	-	-	495	0.42	1.5	40	0.25	1.2	-	-	-
	T8330	0.8	160	0.35	1.5	95	0.32	1.5	-	-	-	480	0.42	1.5	40	0.25	1.2	-	-	-
	T8430	0.8	170	0.35	1.5	90	0.32	1.5	-	-	-	465	0.42	1.5	35	0.25	1.2	-	-	-
	T9325	0.8	200	0.35	1.5	120	0.32	1.5	-	-	-	-	-	45	0.25	1.2	-	-	-	
T9335	0.8	180	0.35	1.5	105	0.32	1.5	-	-	-	-	-	40	0.25	1.2	-	-	-		

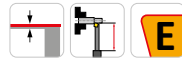
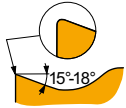

EL-SI geometri, çok pozitif sol kesme yönlü tasarım, ince finişten yarı kaba işleme kadar, ve darbesiz kesim için uygun.

DNMG 110404EL-SI	T7335	0.4	180	0.20	1.0	140	0.18	1.0	-	-	-	-	-	55	0.18	0.8	-	-	-	
	T8330	0.4	160	0.20	1.0	95	0.18	1.0	-	-	-	480	0.24	1.0	40	0.18	0.8	-	-	-
	T8430	0.4	185	0.20	1.0	100	0.18	1.0	-	-	-	510	0.24	1.0	40	0.18	0.8	-	-	-
	T9325	0.4	225	0.20	1.0	135	0.18	1.0	-	-	-	-	-	50	0.18	0.8	-	-	-	



Kesme hızı (vc), ilerleme (f) ve kesme derinliği (ap) için uygunluk ve başlangıç değerleri. Daha ileri hesaplamalar için İşleme Hesaplayıcısı uygulamasına başvurun.

Product	RE (mm)	P			M			K			N			S			H		
		vc (m/min)	f (mm/rev)	ap (mm)	vc (m/min)	f (mm/rev)	ap (mm)	vc (m/min)	f (mm/rev)	ap (mm)	vc (m/min)	f (mm/rev)	ap (mm)	vc (m/min)	f (mm/rev)	ap (mm)	vc (m/min)	f (mm/rev)	ap (mm)

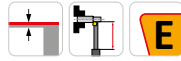
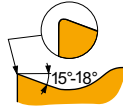

EL-SI geometri, çok pozitif sol kesme yönlü tasarım, ince finiştan yarı kaba işleme kadar, ve darbesiz kesim için uygun.

DNMG 110408EL-SI	T7325	0.8	185	0.35	1.0	140	0.32	1.0	-	-	-	-	-	-	60	0.25	0.8	-	-	-
	T8330	0.8	165	0.35	1.0	95	0.32	1.0	-	-	-	495	0.42	1.0	40	0.25	0.8	-	-	-
	T8430	0.8	180	0.35	1.0	95	0.32	1.0	-	-	-	495	0.42	1.0	35	0.25	0.8	-	-	-
	T9325	0.8	210	0.35	1.0	125	0.32	1.0	-	-	-	-	-	-	45	0.25	0.8	-	-	-
DNMG 150404EL-SI	T8330	0.4	155	0.20	1.5	90	0.18	1.5	-	-	-	465	0.24	1.5	35	0.18	1.2	-	-	-
	T8430	0.4	175	0.20	1.5	95	0.18	1.5	-	-	-	480	0.24	1.5	35	0.18	1.2	-	-	-
	T9325	0.4	220	0.20	1.5	130	0.18	1.5	-	-	-	-	-	-	45	0.18	1.2	-	-	-
DNMG 150408EL-SI	T7335	0.8	170	0.35	1.5	130	0.32	1.5	-	-	-	-	-	-	55	0.25	1.2	-	-	-
	T8330	0.8	160	0.35	1.5	95	0.32	1.5	-	-	-	480	0.42	1.5	40	0.25	1.2	-	-	-
	T8430	0.8	170	0.35	1.5	90	0.32	1.5	-	-	-	465	0.42	1.5	35	0.25	1.2	-	-	-
	T9325	0.8	200	0.35	1.5	120	0.32	1.5	-	-	-	-	-	-	45	0.25	1.2	-	-	-
DNMG 150604EL-SI	T7325	0.4	180	0.20	1.5	140	0.18	1.5	-	-	-	-	-	-	55	0.18	1.2	-	-	-
	T7335	0.4	170	0.20	1.5	130	0.18	1.5	-	-	-	-	-	-	55	0.18	1.2	-	-	-
	T8315	0.4	165	0.20	1.5	95	0.18	1.5	-	-	-	495	0.24	1.5	40	0.18	1.2	-	-	-
	T8330	0.4	155	0.20	1.5	90	0.18	1.5	-	-	-	465	0.24	1.5	35	0.18	1.2	-	-	-
	T8430	0.4	175	0.20	1.5	95	0.18	1.5	-	-	-	480	0.24	1.5	35	0.18	1.2	-	-	-
	T9325	0.4	220	0.20	1.5	130	0.18	1.5	-	-	-	-	-	-	45	0.18	1.2	-	-	-
	T9335	0.4	185	0.20	1.5	110	0.18	1.5	-	-	-	-	-	-	40	0.18	1.2	-	-	-
DNMG 150608EL-SI	T7325	0.8	180	0.35	1.5	140	0.32	1.5	-	-	-	-	-	-	55	0.25	1.2	-	-	-
	T7335	0.8	170	0.35	1.5	130	0.32	1.5	-	-	-	-	-	-	55	0.25	1.2	-	-	-
	T8315	0.8	165	0.35	1.5	95	0.32	1.5	-	-	-	495	0.42	1.5	40	0.25	1.2	-	-	-
	T8330	0.8	160	0.35	1.5	95	0.32	1.5	-	-	-	480	0.42	1.5	40	0.25	1.2	-	-	-
	T8430	0.8	170	0.35	1.5	90	0.32	1.5	-	-	-	465	0.42	1.5	35	0.25	1.2	-	-	-
	T9325	0.8	200	0.35	1.5	120	0.32	1.5	-	-	-	-	-	-	45	0.25	1.2	-	-	-
	T9335	0.8	180	0.35	1.5	105	0.32	1.5	-	-	-	-	-	-	40	0.25	1.2	-	-	-

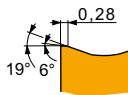

W-MR wiper geometri, finiştan kabaya kadar işleme, yüksek ilerleme hızları ve iyileştirilmiş yüzey finışı için.

DNMG 150608W-MR	T5315	0.8	190	0.40	1.5	-	-	-	180	0.40	1.5	-	-	-	-	-	-	-	-	-
	T9315	0.8	170	0.40	1.5	-	-	-	160	0.40	1.5	-	-	-	-	-	-	-	-	-
	T9325	0.8	155	0.40	1.5	90	0.36	1.5	145	0.40	1.5	-	-	-	-	-	-	-	-	-
DNMG 150612W-MR	T9310	1.2	175	0.50	1.5	-	-	-	165	0.50	1.5	-	-	-	-	-	-	-	-	-
	T9315	1.2	160	0.50	1.5	-	-	-	150	0.50	1.5	-	-	-	-	-	-	-	-	-
	T9325	1.2	145	0.50	1.5	85	0.45	1.5	135	0.50	1.5	-	-	-	-	-	-	-	-	-

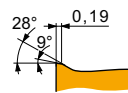

W-NR wiper geometri, finiştan kabaya kadar işleme, yüksek ilerleme hızları ve iyileştirilmiş yüzey finışı için.

DNMX 150604W-NM	T7325	0.4	145	0.30	1.5	110	0.27	1.5	-	-	-	-	-	-	45	0.21	1.2	-	-	-
	T7335	0.4	135	0.30	1.5	105	0.27	1.5	-	-	-	-	-	-	40	0.21	1.2	-	-	-
	T9315	0.4	185	0.30	1.5	-	-	-	175	0.30	1.5	-	-	-	-	-	-	-	-	-
DNMX 150608W-NM	T7325	0.8	155	0.40	1.5	120	0.36	1.5	-	-	-	-	-	-	50	0.28	1.2	-	-	-
	T7335	0.8	145	0.40	1.5	110	0.36	1.5	-	-	-	-	-	-	45	0.28	1.2	-	-	-
	T9315	0.8	195	0.40	1.5	-	-	-	185	0.40	1.5	-	-	-	-	-	-	-	-	-
	T9325	0.8	175	0.40	1.5	105	0.36	1.5	165	0.40	1.5	-	-	-	35	0.28	1.2	-	-	-



DNMM

	IC	D1	L	S
	(mm)	(mm)	(mm)	(mm)
1504	12.700	5.16	15.50	4.76
1506	12.700	5.16	15.50	6.35

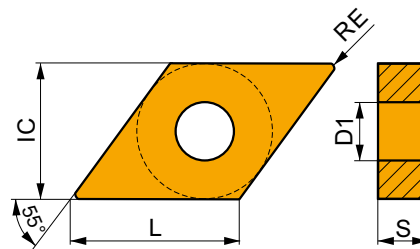

Kesme hızı (vc), ilerleme (f) ve kesme derinliği (ap) için uygunluk ve başlangıç değerleri. Daha ileri hesaplamalar için İşleme Hesaplayıcısı uygulamasına başvurun.

Product	RE	P			M			K			N			S			H		
		vc	f	ap	vc	f	ap	vc	f	ap	vc	f	ap	vc	f	ap	vc	f	ap
	(mm)	(m/min)	(mm/rev)	(mm)	(m/min)	(mm/rev)	(mm)	(m/min)	(mm/rev)	(mm)	(m/min)	(mm/rev)	(mm)	(m/min)	(mm/rev)	(mm)	(m/min)	(mm/rev)	(mm)

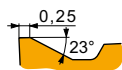

NR geometri, yarı kabadan kaba işleme kadar, darbesizden darbeli kesime kadar uygun.

DNMM 150408E-NR	T9325	0.8	155	0.40	3.0	90	0.36	3.0	145	0.40	3.0	–	–	–	30	0.28	2.4	–	–	–
DNMM 150608E-NR	T7325	0.8	140	0.40	3.0	105	0.36	3.0	–	–	–	–	–	–	45	0.28	2.4	–	–	–
	T8330	0.8	125	0.40	3.0	75	0.36	3.0	115	0.40	3.0	–	–	–	30	0.28	2.4	–	–	–
	T8430	0.8	130	0.40	3.0	70	0.36	3.0	105	0.40	3.0	–	–	–	25	0.28	2.4	–	–	–
	T9325	0.8	155	0.40	3.0	90	0.36	3.0	145	0.40	3.0	–	–	–	30	0.28	2.4	–	–	–

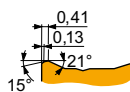

NR2 geometri, yarı kabadan kaba işleme kadar, darbesizden darbeli kesime kadar uygun.

DNMM 150608E-NR2	T9325	0.8	155	0.40	3.0	90	0.36	3.0	145	0.40	3.0	–	–	–	30	0.32	2.4	–	–	–
------------------	-------	-----	-----	------	-----	----	------	-----	-----	------	-----	---	---	---	----	------	-----	---	---	---

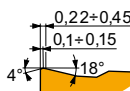

OR geometri, orta kabadan kabaya kadar işlemek için, darbesizden darbeli kesime kadar uygun.

DNMM 150608E-OR	T9325	0.8	155	0.40	3.0	90	0.36	3.0	145	0.40	3.0	–	–	–	30	0.28	2.4	–	–	–
DNMM 150612E-OR	T9315	1.2	180	0.40	3.0	–	–	–	170	0.40	3.0	–	–	–	–	–	–	–	–	–
	T9325	1.2	165	0.40	3.0	95	0.36	3.0	155	0.40	3.0	–	–	–	35	0.32	2.4	–	–	–
	T9335	1.2	145	0.40	3.0	85	0.36	3.0	–	–	–	–	–	–	30	0.32	2.4	–	–	–
DNMM 150616E-OR	T9325	1.6	165	0.45	3.0	95	0.41	3.0	155	0.45	3.0	–	–	–	35	0.41	2.4	–	–	–



DNGA CER

	IC (mm)	D1 (mm)	L (mm)	S (mm)
1504	12.700	5.16	15.50	4.76

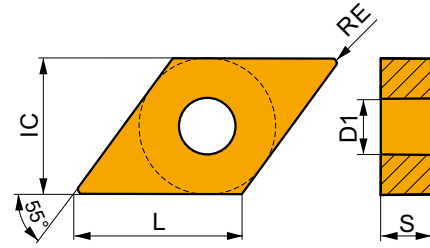

Kesme hızı (vc), ilerleme (f) ve kesme derinliği (ap) için uygunluk ve başlangıç değerleri. Daha ileri hesaplamalar için İşleme Hesaplayıcısı uygulamasına başvurun.

Product	RE (mm)	P			M			K			N			S			H		
		vc (m/min)	f (mm/rev)	ap (mm)	vc (m/min)	f (mm/rev)	ap (mm)	vc (m/min)	f (mm/rev)	ap (mm)	vc (m/min)	f (mm/rev)	ap (mm)	vc (m/min)	f (mm/rev)	ap (mm)			

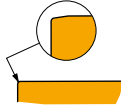

Yüksek hızlı işleme ve darbesiz kesme için.

DNGA 150408 S02020	TC100	0.8	-	-	-	-	-	-	450	0.20	1.5	-	-	-	-	-	-	-
--------------------	-------	-----	---	---	---	---	---	---	-----	------	-----	---	---	---	---	---	---	---

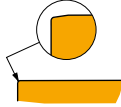

Yüksek hızlı işleme ve darbesiz kesme için.

DNGA 150404 T01020	TC100	0.4	-	-	-	-	-	-	475	0.10	1.5	-	-	-	-	-	-	-
DNGA 150408 T00520	TC100	0.8	-	-	-	-	-	-	450	0.20	1.5	-	-	-	-	-	-	-

DNGN CER

	IC (mm)	L (mm)	S (mm)
1504	12.700	15.50	4.76

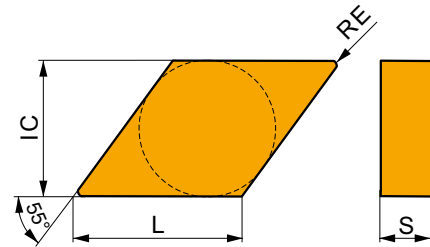

Kesme hızı (vc), ilerleme (f) ve kesme derinliği (ap) için uygunluk ve başlangıç değerleri. Daha ileri hesaplamalar için İşleme Hesaplayıcısı uygulamasına başvurun.

Product	RE (mm)	P			M			K			N			S			H		
		vc (m/min)	f (mm/rev)	ap (mm)	vc (m/min)	f (mm/rev)	ap (mm)	vc (m/min)	f (mm/rev)	ap (mm)	vc (m/min)	f (mm/rev)	ap (mm)	vc (m/min)	f (mm/rev)	ap (mm)			

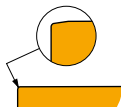
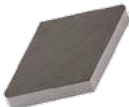

Yüksek hızlı işleme ve darbesiz kesme için.

DNGN 150408 T01020	TC100	0.8	-	-	-	-	-	-	450	0.20	1.5	-	-	-	-	-	-	-
--------------------	-------	-----	---	---	---	---	---	---	-----	------	-----	---	---	---	---	---	---	---



DNGA CBN

	IC	D1	L	S
	(mm)	(mm)	(mm)	(mm)
1506	12.700	5.16	15.50	6.35

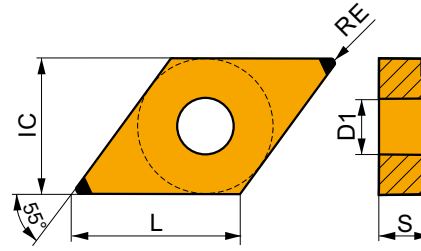

Kesme hızı (vc), ilerleme (f) ve kesme derinliği (ap) için uygunluk ve başlangıç değerleri. Daha ileri hesaplamalar için İşleme Hesaplayıcısı uygulamasına başvurun.

Product	RE	P			M			K			N			S			H		
		vc	f	ap	vc	f	ap	vc	f	ap	vc	f	ap	vc	f	ap			
	(mm)	(m/min)	(mm/rev)	(mm)	(m/min)	(mm/rev)	(mm)	(m/min)	(mm/rev)	(mm)	(m/min)	(mm/rev)	(mm)	(m/min)	(mm/rev)	(mm)	(m/min)	(mm/rev)	(mm)

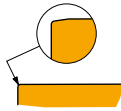

Finiş işleme ve darbesiz kesme için.

DNGA 150608S01020B	TB310	0.8	-	-	-	-	-	420	0.15	0.6	-	-	-	110	0.11	0.5	85	0.15	1.0
--------------------	-------	-----	---	---	---	---	---	-----	------	-----	---	---	---	-----	------	-----	----	------	-----



DDJN(RL) EXT



PRAMET

D

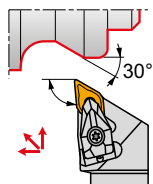

DN.. Uç için Çift Sıkmalı 93° Dış Kateri

Çift sıkmalı 93° Sağ/Sol dış kater. Negatif DN.. 11 veya 16 uçlarla çap, kopya, alın ve pah tornalama için uygundur. 20x20 - 32x32mm şaft ölçüleri. Gövde uzun takım ömrü için işlem görmüştür.

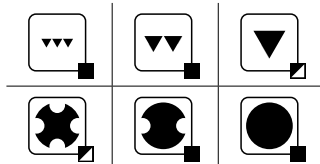
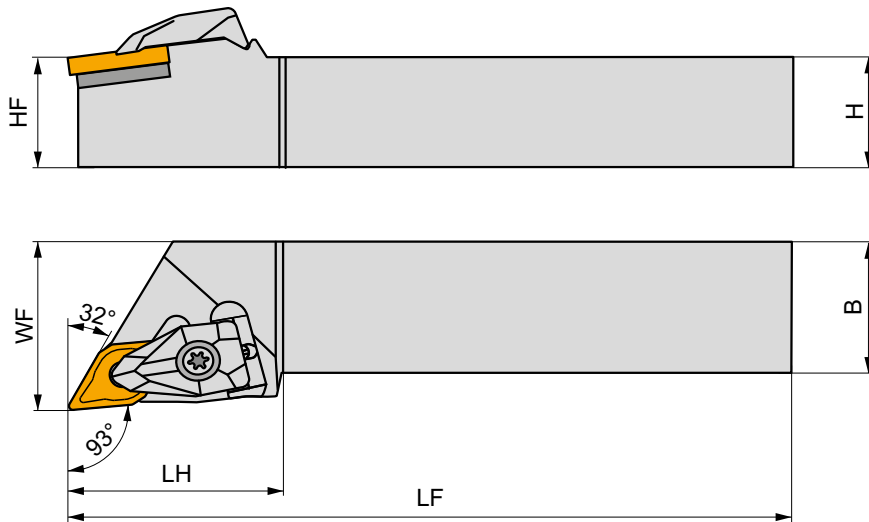

Product	H	B	HF	WF	LF	LH	LAMS	GAMO	kg			
	(mm)	(mm)	(mm)	(mm)	(mm)	(mm)	(°)	(°)				
R DDJNR 2020 K 11	20	20	20	25	125	30.2	-7	-6	0.45	GI046	DD11	-
DDJNR 2525 M 11	25	25	25	32	150	30.2	-7	-6	0.77	GI046	DD11	-
DDJNR 2020 K 15	20	20	20	25	125	39.4	-7	-6	0.42	GI044	DD154	AT002
DDJNR 2525 M 15	25	25	25	32	150	39.4	-7	-6	0.74	GI044	DD154	AT002
DDJNR 3225 P 15	32	25	32	32	170	39.4	-7	-6	1.12	GI044	DD154	AT002
DDJNR 3232 P 15	32	32	32	40	170	39.4	-7	-6	1.33	GI044	DD154	AT002
L DDJNL 2020 K 11	20	20	20	25	125	30.2	-7	-6	0.45	GI046	DD11	-
DDJNL 2525 M 11	25	25	25	32	150	30.2	-7	-6	0.77	GI046	DD11	-
DDJNL 2020 K 15	20	20	20	25	125	39.4	-7	-6	0.42	GI044	DD154	AT002
DDJNL 2525 M 15	25	25	25	32	150	39.4	-7	-6	0.74	GI044	DD154	AT002
DDJNL 3225 P 15	32	25	32	32	170	39.4	-7	-6	1.01	GI044	DD154	AT002
DDJNL 3232 P 15	32	32	32	40	170	39.4	-7	-6	1.34	GI044	DD154	AT002



GI044

DN.. 1506..

GI046

DN.. 1104..



DD11

DCS 09

1.7

DDS 267-01

US 2004-T09P

FLAG T09P

DD154

DCS 12

3.9

DDS 266-02

US 2002-T15P

FLAG T15P/3,5



AT002a

DN.. 1504..

-

DDS 266-01

AT002b

CER DN.N 1506..

DCS 12C4

-

AT002c

CER DN.A 1506..

DCS 12C2

-



PDJN(RL) EXT

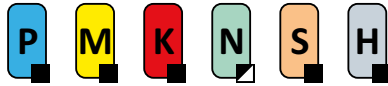

PRAMET

P



DN.. Uç için Levveli 93° Açılı Dış Kater

Levveli, 93° açılı Sağ/Sol dış kater. Negatif DN.. 11 veya 15 uçlarla çap, 30°'ye kadar kopya ve pah tormalamak için uygundur. 20x20'den 32x32mm'ye kadar mevcuttur. Gövde uzun takım ömrü için işlem görmüştür.

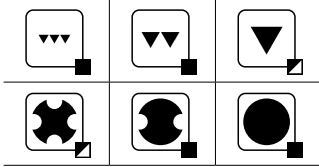
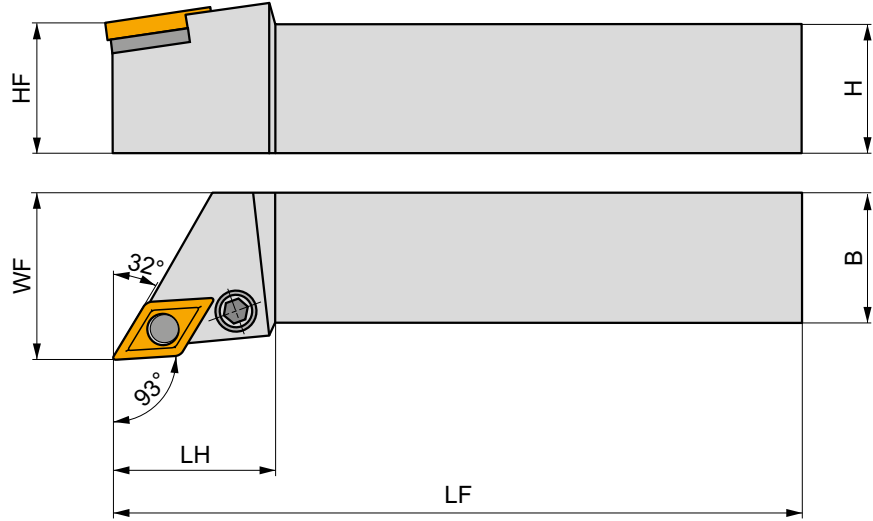
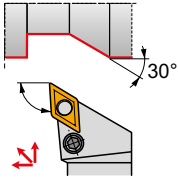

Product	H	B	HF	WF	LF	LH	LAMS	GAMO	kg		
	(mm)	(mm)	(mm)	(mm)	(mm)	(mm)	(°)	(°)			
R PDJNR 2020 K 11	20	20	20	25	125	30	-6	-6	0.43	GI046	PD60
PDJNR 2525 M 11	25	25	25	32	150	30	-6	-6	0.73	GI046	PD60
PDJNR 3225 P 11	32	25	32	32	170	30	-6	-6	1.10	GI046	PD60
PDJNR 2020 K 15	20	20	20	25	125	40	-6	-6	0.44	GI044	PD31
PDJNR 2525 M 15	25	25	25	32	150	40	-6	-6	0.73	GI044	PD30
PDJNR 3225 P 15	32	25	32	32	170	40	-6	-6	1.05	GI044	PD30
PDJNR 3232 P 15	32	32	32	40	170	40	-6	-6	1.30	GI044	PD30
L PDJNL 2020 K 11	20	20	20	25	125	30	-6	-6	0.41	GI046	PD60
PDJNL 2525 M 11	25	25	25	32	150	30	-6	-6	0.73	GI046	PD60
PDJNL 3225 P 11	32	25	32	32	170	30	-6	-6	1.10	GI046	PD60
PDJNL 2020 K 15	20	20	20	25	125	40	-6	-6	0.42	GI044	PD31
PDJNL 2525 M 15	25	25	25	32	150	40	-6	-6	0.73	GI044	PD30
PDJNL 3225 P 15	32	25	32	32	170	40	-6	-6	0.98	GI044	PD30
PDJNL 3232 P 15	32	32	32	40	170	40	-6	-6	1.30	GI044	PD30



GI044

DN.. 1506..

GI046

DN.. 1104..



PD30

DNU 150308

PU 03

US 36

6.0

M 8x1

26

NT 05

MT 05

HXK 4

PD31

DNU 150308

PU 03

US 40

6.0

M 8x1

20.5

NT 05

MT 05

HXK 4

PD60

PDN 110308

PU 3512

PS 0616

3.0

M 6

16

NT 5153

MT 0912

HXK 2.5

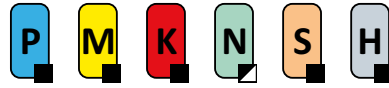
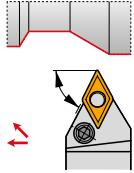

PDNN(RL) EXT

DN.. Uç için Levveli 63° Açılı Dış Kater

Levveli, 63° açılı nötr dış kater. Negatif DN.. 15 uçlarla çap, konik, kopya ve pah tornalamak için uygundur. 20x20'den 32x25'e kadar mevcuttur. Gövde uzun takım ömrü için işlem görmüştür.

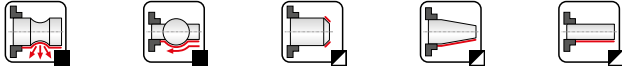
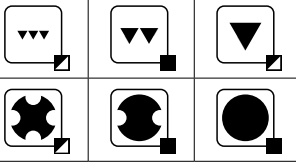
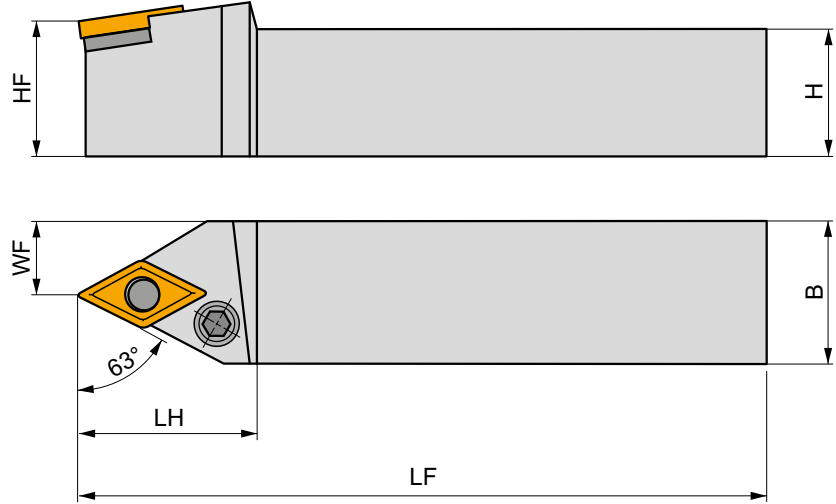

Product	H	B	HF	WF	LF	LH	LAMS	GAMO	kg	GI046	GI044
	(mm)	(mm)	(mm)	(mm)	(mm)	(mm)	(°)	(°)			
R PDNNR 2020 K 11	20	20	20	10	125	24	-6	-6	0.39	GI046	PD60
PDNNR 2525 M 11	25	25	25	12.5	150	30	-6	-6	0.60	GI046	PD60
PDNNR 2525 M 15	25	25	25	12.5	150	40	-6	-6	0.64	GI044	PD30
PDNNR 3225 P 15	32	25	32	12.5	170	40	-6	-6	1.05	GI044	PD30
L PDNNL 2020 K 11	20	20	20	10	125	24	-6	-6	0.40	GI046	PD60
PDNNL 2525 M 11	25	25	25	12.5	150	30	-6	-6	0.60	GI046	PD60
PDNNL 2525 M 15	25	25	25	12.5	150	40	-6	-6	0.07	GI044	PD30
PDNNL 3225 P 15	32	25	32	12.5	170	40	-6	-6	1.05	GI044	PD30



GI044
GI046



DN.. 1506..
DN.. 1104..



PD30

DNU 150308

PU 03

US 36

6.0

M 8x1

26

NT 05

MT 05

HXK 4

PD60

PDN 110308

PU 3512

PS 0616

3.0

M 6

16

NT 5153

MT 0912

HXK 2.5



PDXN(RL) EXT



PRAMET

P



DN.. Uç için Levveli 98° Açılı Dış Kater

Levveli, 98° açılı Sağ/Sol dış kater. Negatif DN.. 15 uçlarla çap, 22°'ye kadar kopya, konik ve pah tornalamak için uygundur. 20x20'den 32x25mm'ye kadar mevcuttur. Gövde uzun takım ömrü için işlem görmüştür.

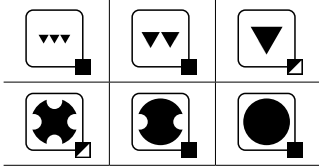
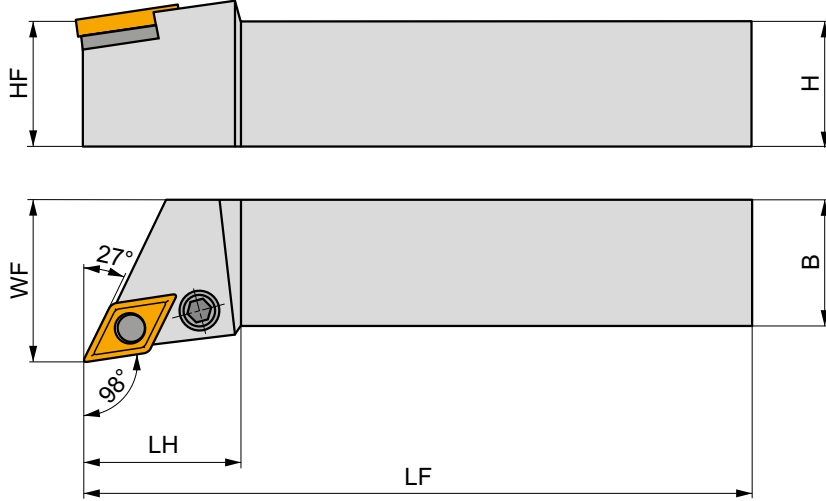
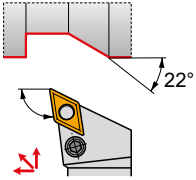

Product	H	B	HF	WF	LF	LH	LAMS	GAMO	kg		
	(mm)	(mm)	(mm)	(mm)	(mm)	(mm)	(°)	(°)			
R PDXNR 2020 K 15	20	20	20	25	125	40	-6	-6	0.43	GI044	PD31
PDXNR 2525 M 15	25	25	25	32	150	40	-6	-6	0.73	GI044	PD30
PDXNR 3225 P 15	32	25	32	32	170	40	-6	-6	0.80	GI044	PD30
L PDXNL 2020 K 15	20	20	20	25	125	40	-6	-6	0.42	GI044	PD31
PDXNL 2525 M 15	25	25	25	32	150	40	-6	-6	0.71	GI044	PD30
PDXNL 3225 P 15	32	25	32	32	170	40	-6	-6	0.95	GI044	PD30



GI044



DN.. 1506..



PD30



DNU 150308



PU 03



US 36



Nm



M 8x1



26



NT 05



MT 05



HXK 4

PD31

DNU 150308

PU 03

US 40

6.0

M 8x1

20.5

NT 05

MT 05

HXK 4

NEW
C.-DDJN(RL) EXT

PRAMET
D

DN.. Uç için Çift Sıkmalı, 93° Açılı Hızlı Değişirme Dış Takımı

Çift sıkmalı, 93° açılı, içten su vermeli Sağ/Sol dış kater. Negatif DN.. 11 veya 15 uçlarla çap, konik ve pah tornalamak için uygundur. C4 - C6 şaftlı mevcuttur. Tutucu uzun takım ömrü için işlem görmüştür.

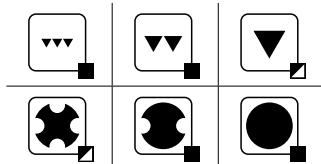
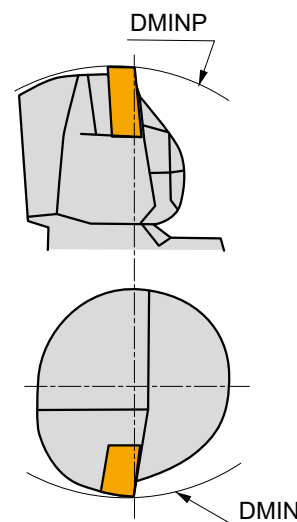
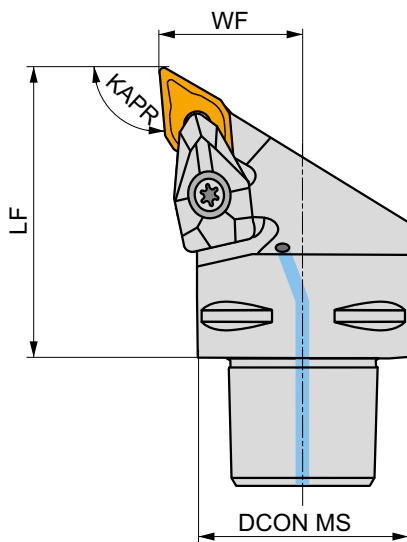
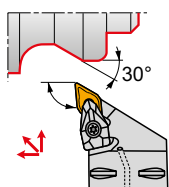

Product	DCON MS	DMIN	DMINP	WF	LF	KAPR	LAMS	GAMO	✓	kg	GI046	C-DD11	AT002	
	(mm)	(mm)	(mm)	(mm)	(mm)	(°)	(°)	(°)						
R	C4-DDJNR-27050-11	40	60	140	27	50	93	-7	-6	✓	0.38	GI046	C-DD11	-
	C4-DDJNR-27055-15	40	110	145	27	55	93	-7	-6	✓	0.43	GI044	C-DD154-1	AT002
	C5-DDJNR-35060-15	50	110	165	35	60	93	-7	-6	✓	0.72	GI044	C-DD154-2	AT002
	C6-DDJNR-45065-15	63	110	190	45	65	93	-7	-6	✓	1.18	GI044	C-DD154-3	AT002
L	C4-DDJNL-27050-11	40	60	140	27	50	93	-7	-6	✓	0.39	GI046	C-DD11	-
	C4-DDJNL-27055-15	40	110	145	27	55	93	-7	-6	✓	0.43	GI044	C-DD154-1	AT002
	C5-DDJNL-35060-15	50	110	165	35	60	93	-7	-6	✓	0.72	GI044	C-DD154-2	AT002
C6-DDJNL-45065-15	63	110	190	45	65	93	-7	-6	✓	1.18	GI044	C-DD154-3	AT002	

 GI044
 GI046

 DN.. 1506..
 DN.. 1104..

Nm

C-DD11	DCS 09	1.7	DDS 267-01	US 2004-T09P	FLAG T09P	CN 034-01
C-DD154-1	DCS 12	3.9	DDS 266-02	US 2002-T15P	FLAG T15P/3,5	CN 034-01
C-DD154-2	DCS 12	3.9	DDS 266-02	US 2002-T15P	FLAG T15P/3,5	CN 045-01
C-DD154-3	DCS 12	3.9	DDS 266-02	US 2002-T15P	FLAG T15P/3,5	CN 034-02

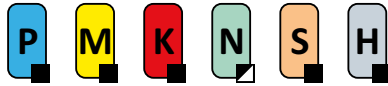

AT002a	DN.. 1504..	-	DDS 266-01
AT002b	CER DN.N 1506..	DCS 12C4	-
AT002c	CER DN.A 1506..	DCS 12C2	-
AT002d	CER DN.N 1504..	DCS 12C4	DDS 266-01
AT002e	CER DN.A 1504..	DCS 12C2	DDS 266-01

NEW
C.-DDNNN EXT

PRAMET
D

DN.. Uç için Çift Sıkmalı, 62.5° Açılı Hızlı Değişirme Dış Takımı

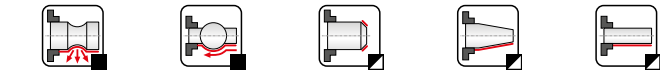
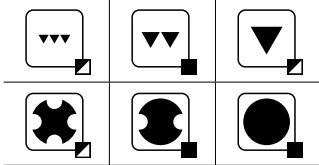
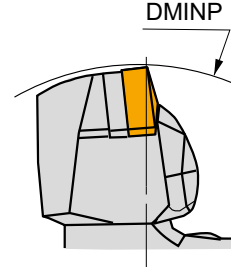
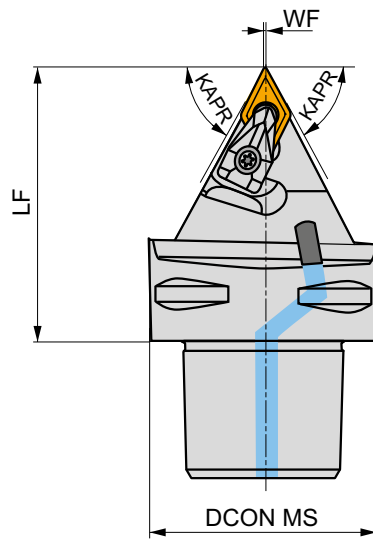
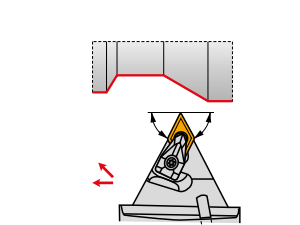
Çift sıkmalı, 62.5° açılı, içten su vermeli Sağ/Sol dış kater. Negatif DN.. 15 uçlarla çap, alın, konik ve pah tornalamak için uygundur. C6 şaftlı mevcuttur. Tutucu uzun takım ömrü için işlem görmüştür.



Product	DCON MS (mm)	DMINP (mm)	WF (mm)	LF (mm)	KAPR (°)	LAMS (°)	GAMO (°)		kg			
N C5-DDNNN-00060-15	50	165	0.5	60	62.5	-9	-5	✓	0.62	GI044	C-DD154-2	AT002
C6-DDNNN-00065-15	63	190	0.5	65	62.5	-9	-5	✓	1.06	GI044	C-DD154-2	AT002

GI044	DN.. 1506..

C-DD154-2	DCS 12	3.9	DDS 266-02	US 2002-T15P	FLAG T15P/3,5	CN 045-01

AT002a	DN.. 1504..	-	DDS 266-01
AT002b	CER DN.N 1506..	DCS 12C4	-
AT002c	CER DN.A 1506..	DCS 12C2	-
AT002d	CER DN.N 1504..	DCS 12C4	DDS 266-01
AT002e	CER DN.A 1504..	DCS 12C2	DDS 266-01

NEW
C.-DDUN(RL) EXT

PRAMET
D

DN.. Uç için Çift Sıklımlı, 93° Açılı (Alın) Hızlı Değişirme Dış Takımı

Çift sıklımlı, 93° açılı, içten su vermeli Sağ/Sol dış kater. Negatif DN.. 15 uçlarla çap, alın, konik ve pah tornalamak için uygundur. C4 - C6 şaftlı mevcuttur. Tutucu uzun takım ömrü için işlem görmüştür.

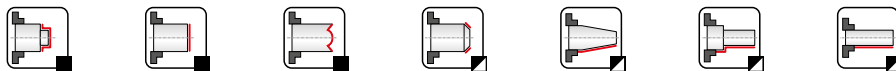
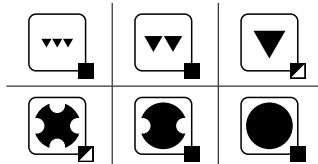
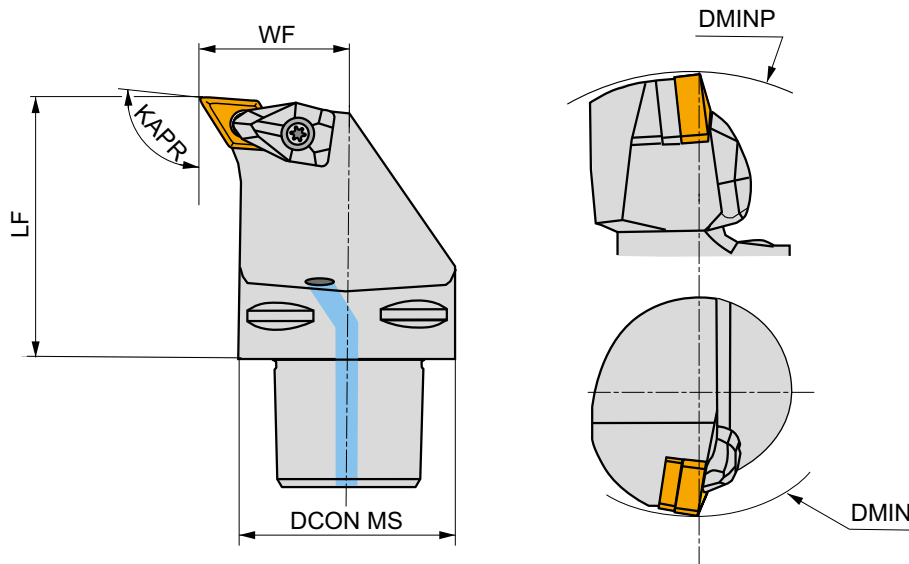
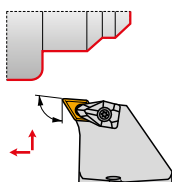

Product	DCON MS (mm)	DMIN (mm)	DMINP (mm)	WF (mm)	LF (mm)	KAPR (°)	LAMS (°)	GAMO (°)	✓	kg	GI044	C-DD154-3	AT002
R C5-DDUNR-35060-15	50	110	165	35	60	93	-7	-6	✓	0.82	GI044	C-DD154-3	AT002
C6-DDUNR-45065-15	63	110	190	45	65	93	-7	-6	✓	1.39	GI044	C-DD154-3	AT002
L C5-DDUNL-35060-15	50	110	165	35	60	93	-7	-6	✓	0.82	GI044	C-DD154-3	AT002



GI044



DN.. 1506..



C-DD154-3



DCS 12



3.9



DDS 266-02



US 2002-T15P



FLAG T15P/3,5



CN 034-02



AT002a



DN.. 1504..



DCS 12C4



DDS 266-01

AT002b

CER DN.N 1506..

DCS 12C4

DDS 266-01

AT002c

CER DN.A 1506..

DCS 12C2

DDS 266-01

AT002d

CER DN.N 1504..

DCS 12C4

DDS 266-01

AT002e

CER DN.A 1504..

DCS 12C2

DDS 266-01



DDUN(RL) INT



PRAMET

D



DN.. Uç için Çift Sıkmalı 93° Açılı Delik Kateri

Çift sıkmalı 93° Sağ/Sol içten su vermeli delik kateri. Negatif DN.. 11 veya 15 uçlarla minimum Ø32mm çap, birçok uygulama ve 27°'ye kadar kopya tornalama için uygundur. Ø25-50mm şaft ölçüleri. Gövde uzun takım ömrü için işlem görmüştür.

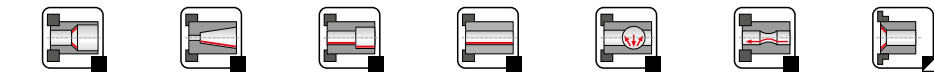
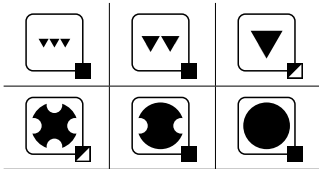
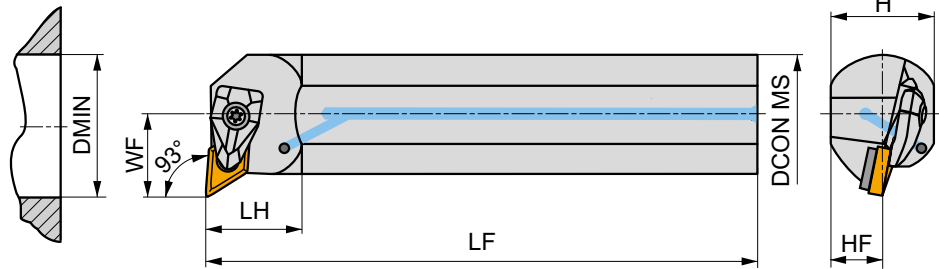
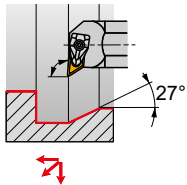

Product	DCON MS (mm)	DMIN (mm)	WF (mm)	H (mm)	HF (mm)	LF (mm)	LH (mm)	LAMS (°)	GAMO (°)	✓	kg	GI046	DD11	AT002
R A25T-DDUNR 11	25	32	17	23	11.5	300	28	-12	-6	✓	0.96	GI046	DD11	-
A32T-DDUNR 11	32	40	22	30	15	300	30	-10	-6	✓	1.68	GI046	DD11	-
A40T-DDUNR 15	40	50	27	37	18.5	300	36	-11	-6	✓	2.59	GI044	DD154	AT002
A50U-DDUNR 15	50	63	35	47	23.5	350	39	-8	-6	✓	5.23	GI044	DD154	AT002
L A25T-DDUNL 11	25	32	17	23	11.5	300	28	-12	-6	✓	0.96	GI046	DD11	-
A32T-DDUNL 11	32	40	22	30	15	300	30	-10	-6	✓	1.69	GI046	DD11	-
A40T-DDUNL 15	40	50	27	37	18.5	300	36	-11	-6	✓	2.59	GI044	DD154	AT002
A50U-DDUNL 15	50	63	35	47	23.5	350	39	-8	-6	✓	5.25	GI044	DD154	AT002

GI044	GI046	DN.. 1506..	DN.. 1104..

DD11	DCS 09	1.7	DDS 267-01	US 2004-T09P	FLAG T09P
DD154	DCS 12	3.9	DDS 266-02	US 2002-T15P	FLAG T15P/3,5

AT002a	DN.. 1504..	-	DDS 266-01
AT002b	CER DN.N 1506..	DCS 12C4	-
AT002c	CER DN.A 1506..	DCS 12C2	-



PDUN(RL) INT



DN.. Uç için Levye 93° Açılı Delik Kateri

Levyeli 93° Sağ/Sol içten su vermeli delik kateri. Negatif DN.. 11 veya 15 uçlarla minimum Ø32mm çap, birçok uygulama ve 27°'ye kadar kopya tornalama için uygundur. Ø25-60mm shaft ölçüleri. Gövde uzun takım ömrü için işlem görmüştür.

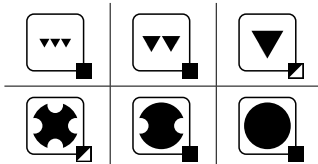
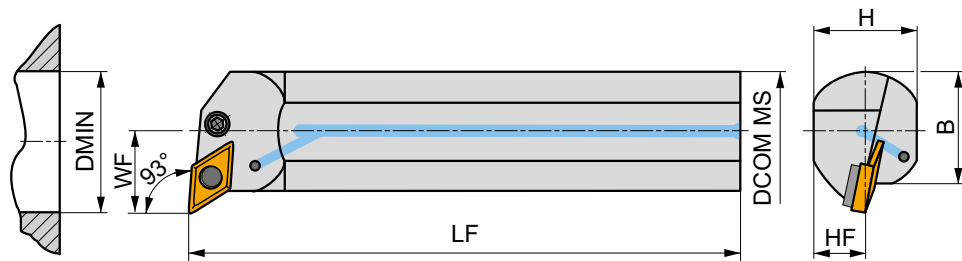
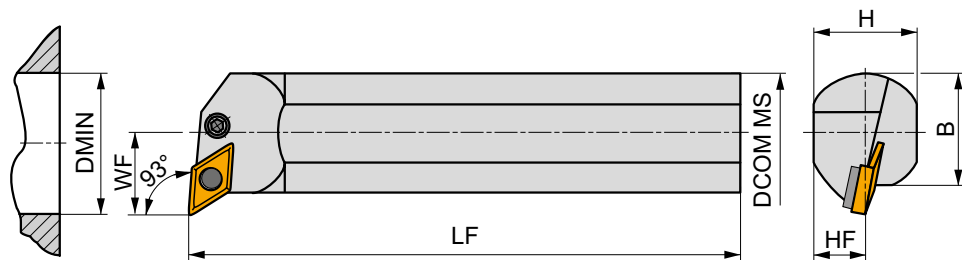
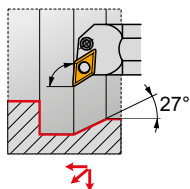

Product	DCOM MS	DMIN	WF	H	B	LF	LAMS	GAMO					
	(mm)	(mm)	(mm)	(mm)	(mm)	(mm)	(°)	(°)					
R	S25T-PDUNR 11-A	25	32	17	23	23	300	-12	-6	-	1.10	GI046	PD61
	S32U-PDUNR 11	32	40	22	30	30	350	-12	-6	-	2.10	GI046	PD60
	A32S-PDUNR 15	32	40	32	30	30	250	-12	-6	✓	1.47	GI097	PD33
	A40T-PDUNR 15	40	50	27	38	38	300	-12	-6	✓	2.40	GI097	PD30
	A50U-PDUNR 15	50	63	35	47	48.5	350	-12	-6	✓	4.95	GI097	PD30
	A60V-PDUNR 15	60	80	43	57	58.5	400	-12	-6	✓	8.22	GI097	PD30
L	S25T-PDUNL 11-A	25	32	17	23	23	300	-12	-6	-	1.11	GI046	PD61
	S32U-PDUNL 11	32	40	22	30	30	350	-12	-6	-	2.09	GI046	PD60
	A32S-PDUNL 15	32	40	32	30	30	250	-12	-6	✓	1.47	GI097	PD33
	A40T-PDUNL 15	40	50	27	38	38	300	-12	-6	✓	2.56	GI097	PD30
	A50U-PDUNL 15	50	63	35	47	48.5	350	-12	-6	✓	5.20	GI097	PD30
	A60V-PDUNL 15	60	80	43	57	58.5	400	-12	-6	✓	8.16	GI097	PD30



G1046
G1097



DN.. 1104..
DN.. 1504..



PD30

DNU 150308

PU 03

US 36

6.0

M 8x1

26

NT 05

MT 05

HXK 4

PD33

-

PU 03-A

US 41

6.0

M 8x1

17

NT 15

MT 05

HXK 4

PD60

PDN 110308

PU 3512

PS 0616

3.0

M 6

16

NT 5153

MT 0912

HXK 2.5

PD61

-

PU 3611-A

PS 0512-A

2.0

M 5

12

-

-

HXK 2

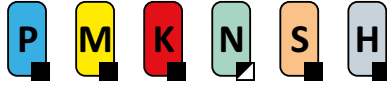
NEW
C-DDUN(RL) INT

PRAMET
D

DN.. Uçlar için Çift Sıkmalı 93° Açılı PSC Hızlı Değişirme Delik Takımı

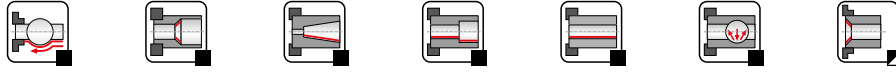
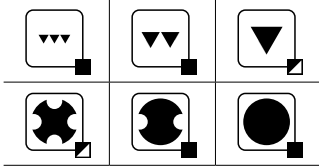
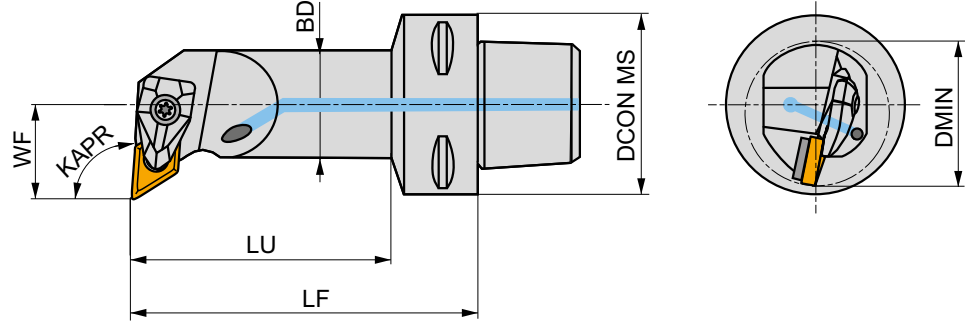
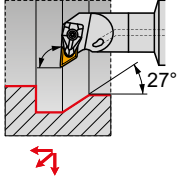
Çift sıkmalı 93° Sağ/Sol içten su vermeli delik kateri. Negatif DN.. 11 uçlarla minimum Ø32mm çap, ve 27°'ye kadar kopyalama dahil birçok çeşit tornalama için uygundur. PSC C4 şaft ve 68mm boy ölçüleri. Gövde uzun takım ömrü için işlem görmüştür.



Product	DCON MS (mm)	DMIN (mm)	WF (mm)	LF (mm)	LU (mm)	BD (mm)	KAPR (°)	LAMS (°)	GAMO (°)				
R C4-DDUNR-17090-11	40	32	17	90	68	25	93	-12	-6	✓	0.51	G1046	DD11
L C4-DDUNL-17090-11	40	32	17	90	68	25	93	-12	-6	✓	0.51	G1046	DD11



G1046



DN.. 1104..



DD11



DCS 09



1.7



DDS 267-01



US 2004-T09P



FLAG T09P



KN

16

KARBÜR UÇLAR

KNUX



284

DOĞRU BOYUTLA EŞLEŞTİRİN (örnek)

Kesici uç

KNUX 160405L-22

Takım Tutucu

CKJNR 2020 K 16

ISO TORNALAMA - DIŞ

CKJN(RL) EXT

93°

KN..

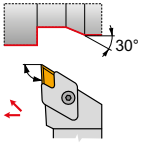

16

20×20
32×25

287

284 – 286



KNUX



	W1 (mm)	L (mm)	S (mm)
1604	9.525	19.50	4.76

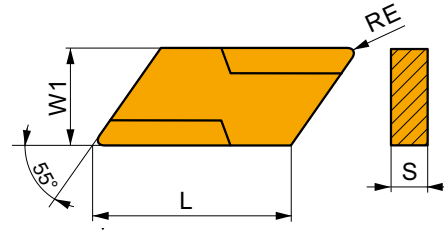

Kesme hızı (vc), ilerleme (f) ve kesme derinliği (ap) için uygunluk ve başlangıç değerleri. Daha ileri hesaplamalar için İşleme Hesaplayıcısı uygulamasına başvurun.

Product	RE (mm)	P			M			K			N			S			H		
		vc (m/min)	f (mm/rev)	ap (mm)	vc (m/min)	f (mm/rev)	ap (mm)	vc (m/min)	f (mm/rev)	ap (mm)	vc (m/min)	f (mm/rev)	ap (mm)	vc (m/min)	f (mm/rev)	ap (mm)			

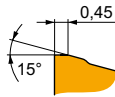

L-22 sol kesme yönlü geometri, finiştan yarı kaba işlemeye kadar, darbesiz kesimler için.

KNUX 160405L-22	T5315	0.5	190	0.25	2.7	–	–	–	180	0.25	2.7	–	–	–	–	–	–	–
	T7325	0.5	130	0.25	2.7	100	0.25	2.7	–	–	–	–	–	–	–	–	–	–
	T7335	0.5	125	0.25	2.7	95	0.25	2.7	–	–	–	–	–	–	–	–	–	–
	T9325	0.5	155	0.25	2.7	90	0.25	2.7	145	0.25	2.7	–	–	–	–	–	–	–
	T9335	0.5	135	0.25	2.7	80	0.25	2.7	–	–	–	–	–	–	–	–	–	–

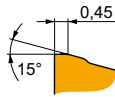

R-22 sağ kesme yönlü geometri, finiştan yarı kaba işlemeye kadar, darbesiz kesimler için.

KNUX 160405R-22	T5315	0.5	190	0.25	2.7	–	–	–	180	0.25	2.7	–	–	–	–	–	–	–
	T7325	0.5	130	0.25	2.7	100	0.25	2.7	–	–	–	–	–	–	–	–	–	–
	T7335	0.5	125	0.25	2.7	95	0.25	2.7	–	–	–	–	–	–	–	–	–	–
	T9325	0.5	155	0.25	2.7	90	0.25	2.7	145	0.25	2.7	–	–	–	–	–	–	–
	T9335	0.5	135	0.25	2.7	80	0.25	2.7	–	–	–	–	–	–	–	–	–	–

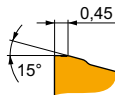

L-22 sol kesme yönlü geometri, finiştan yarı kaba işlemeye kadar, darbesiz kesimler için.

KNUX 160410L-22	T9335	1.0	155	0.32	2.7	90	0.29	2.7	–	–	–	–	–	–	–	–	–	–
-----------------	-------	-----	-----	------	-----	----	------	-----	---	---	---	---	---	---	---	---	---	---

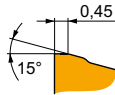

R-22 sağ kesme yönlü geometri, finiştan yarı kaba işlemeye kadar, darbesiz kesimler için.

KNUX 160410R-22	T9335	1.0	155	0.32	2.7	90	0.29	2.7	–	–	–	–	–	–	–	–	–	–
-----------------	-------	-----	-----	------	-----	----	------	-----	---	---	---	---	---	---	---	---	---	---

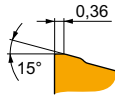









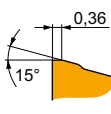
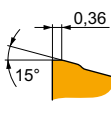

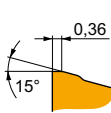
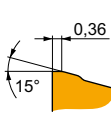

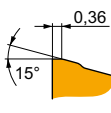
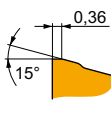

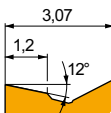
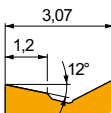

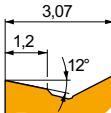
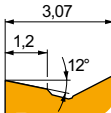
L-32 sol kesme yönlü geometri, finiştan yarı kaba işlemeye kadar, darbesiz kesimler için.

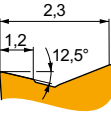
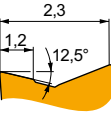
KNUX 160405L-32	T5315	0.5	190	0.25	2.7	–	–	–	180	0.25	2.7	–	–	–	–	–	–	–
	T7325	0.5	130	0.25	2.7	100	0.25	2.7	–	–	–	–	–	–	–	–	–	–
	T7335	0.5	125	0.25	2.7	95	0.25	2.7	–	–	–	–	–	–	–	–	–	–
	T9325	0.5	155	0.25	2.7	90	0.25	2.7	145	0.25	2.7	–	–	–	–	–	–	–
	T9335	0.5	135	0.25	2.7	80	0.25	2.7	–	–	–	–	–	–	–	–	–	–

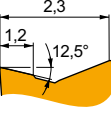
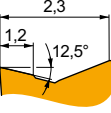

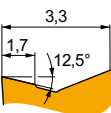
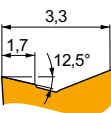
Kesme hızı (vc), ilerleme (f) ve kesme derinliği (ap) için uygunluk ve başlangıç değerleri. Daha ileri hesaplamalar için İşleme Hesaplayıcısı uygulamasına başvurun.

Product	RE (mm)	P			M			K			N			S			H				
		vc (m/min)	f (mm/rev)	ap (mm)	vc (m/min)	f (mm/rev)	ap (mm)	vc (m/min)	f (mm/rev)	ap (mm)	vc (m/min)	f (mm/rev)	ap (mm)	vc (m/min)	f (mm/rev)	ap (mm)	vc (m/min)	f (mm/rev)	ap (mm)		
 R-32 sağ kesme yönlü geometri, finiştan yarı kaba işleme kadar, darbesiz kesimler için.	 0,36 15°		T5315	0.5	190	0.25	2.7	–	–	–	180	0.25	2.7	–	–	–	–	–	–	–	
			T7325	0.5	130	0.25	2.7	100	0.25	2.7	–	–	–	–	–	–	–	–	–	–	–
			T7335	0.5	125	0.25	2.7	95	0.25	2.7	–	–	–	–	–	–	–	–	–	–	–
			T9325	0.5	155	0.25	2.7	90	0.25	2.7	145	0.25	2.7	–	–	–	–	–	–	–	–
			T9335	0.5	135	0.25	2.7	80	0.25	2.7	–	–	–	–	–	–	–	–	–	–	–
 L-32 sol kesme yönlü geometri, finiştan yarı kaba işleme kadar, darbesiz kesimler için.	 0,36 15°		T9325	1.0	175	0.32	2.7	105	0.29	2.7	165	0.32	2.7	–	–	–	–	–	–	–	
			T9335	1.0	155	0.32	2.7	90	0.29	2.7	–	–	–	–	–	–	–	–	–	–	–
 R-32 sağ kesme yönlü geometri, finiştan yarı kaba işleme kadar, darbesiz kesimler için.	 0,36 15°		T9325	1.0	175	0.32	2.7	105	0.29	2.7	165	0.32	2.7	–	–	–	–	–	–	–	
			T9335	1.0	155	0.32	2.7	90	0.29	2.7	–	–	–	–	–	–	–	–	–	–	–
 ER-72 geometri, sağ kesme yönlü tasarım, ince ve finiş işleme kadar, ve darbesiz kesim için uygun.	 3,07 1,2 12°		T5315	0.5	250	0.20	2.0	–	–	–	235	0.20	2.0	–	–	–	–	–	–	–	
			T9325	0.5	215	0.20	2.0	125	0.18	2.0	200	0.20	2.0	–	–	–	45	0.16	1.6	–	–
			T9335	0.5	185	0.20	2.0	110	0.18	2.0	–	–	–	–	–	–	40	0.16	1.6	–	–
 EL-72 geometri, sol kesme yönlü tasarım, ince ve finiş işleme kadar, ve darbesiz kesim için uygun.	 3,07 1,2 12°		T5315	0.5	250	0.20	2.0	–	–	–	235	0.20	2.0	–	–	–	–	–	–	–	
			T9325	0.5	215	0.20	2.0	125	0.18	2.0	200	0.20	2.0	–	–	–	45	0.16	1.6	–	–
			T9335	0.5	185	0.20	2.0	110	0.18	2.0	–	–	–	–	–	–	40	0.16	1.6	–	–
 ER-73 geometri, sağ kesme yönlü tasarım, finiş ve yarı kaba işleme kadar, ve darbesiz kesim için uygun.	 2,3 1,2 12,5°		KNUX 160405SR-73	6640	0.5	150	0.25	3.0	90	0.23	3.0	140	0.25	3.0	–	–	–	–	–	–	
			KNUX 160410SR-73	6640	1.0	150	0.40	3.0	90	0.36	3.0	140	0.40	3.0	–	–	–	–	–	–	–
			T5315	1.0	235	0.40	3.0	–	–	–	220	0.40	3.0	–	–	–	–	–	–	–	–
 EL-73 geometri, sol kesme yönlü tasarım, finiş ve yarı kaba işleme kadar, ve darbesiz kesim için uygun.	 2,3 1,2 12,5°		KNUX 160405SL-73	6640	0.5	150	0.25	3.0	90	0.23	3.0	140	0.25	3.0	–	–	–	–	–	–	
			KNUX 160410SL-73	6640	1.0	150	0.40	3.0	90	0.36	3.0	140	0.40	3.0	–	–	–	–	–	–	–
 ER-74 geometri, sağ kesme yönlü tasarım, finiştan kaba işleme kadar, ve darbesiz kesim için uygun.	 3,3 1,7 12,5°		KNUX 160415SR-74	6640	1.5	155	0.45	3.0	90	0.41	3.0	145	0.45	3.0	–	–	–	–	–	–	



Kesme hızı (vc), ilerleme (f) ve kesme derinliği (ap) için uygunluk ve başlangıç değerleri. Daha ileri hesaplamalar için İşleme Hesaplayıcısı uygulamasına başvurun.

Product	RE (mm)	P			M			K			N			S			H		
		vc (m/min)	f (mm/rev)	ap (mm)	vc (m/min)	f (mm/rev)	ap (mm)	vc (m/min)	f (mm/rev)	ap (mm)	vc (m/min)	f (mm/rev)	ap (mm)	vc (m/min)	f (mm/rev)	ap (mm)	vc (m/min)	f (mm/rev)	ap (mm)

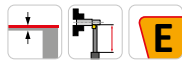
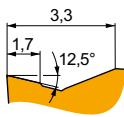

EL-74 geometri, sol kesme yönlü tasarım, finişten kaba işlemeye kadar, ve darbesiz kesim için uygun.

KNUX 160415SL-74	6640	1.5	■	155	0.45	3.0	☑	90	0.41	3.0	■	145	0.45	3.0	—	—	—	—	—	—
-------------------------	-------------	-----	---	-----	------	-----	---	----	------	-----	---	-----	------	-----	---	---	---	---	---	---



CKJN(RL) EXT



PRAMET

C



KN.. Uç için Üstten Pabuç Sıkmalı, 93° Açılı Dış Kater

Pabuç sıkmalı Sağ/Sol 93° dış kater. Negatif KN.. 16 uçlarla çap, 30°'ye kadar kopya, konik ve pah tornalama için uygundur. 20x20-32-25mm şaft ölçülerinde bulunur.

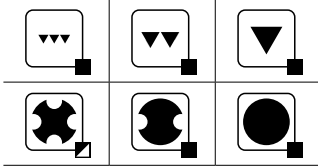
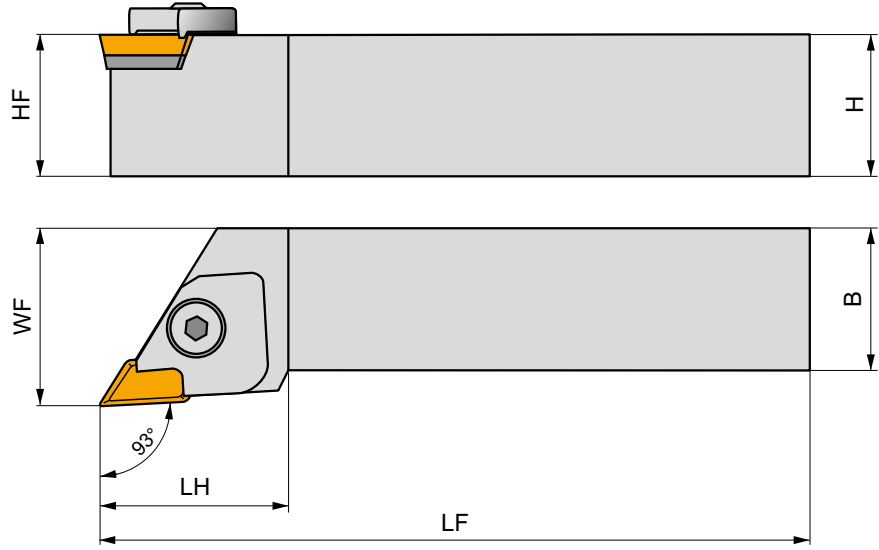
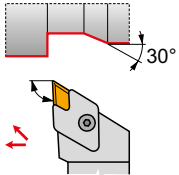

Product	H	B	HF	WF	LF	LH	LAMS	GAMO	kg	GI066	GI067
	(mm)	(mm)	(mm)	(mm)	(mm)	(mm)	(°)	(°)			
R CKJNR 2020 K 16	20	20	20	30	125	34	1	-5	0.43	GI066	R1
CKJNR 2525 M 16	25	25	25	32	150	34	1	-5	0.70	GI066	R
CKJNR 3225 P 16	32	25	32	32	170	34	1	-5	1.05	GI066	R
L CKJNL 2020 K 16	20	20	20	30	125	34	1	-5	0.43	GI067	L1
CKJNL 2525 M 16	25	25	25	32	150	34	1	-5	0.74	GI067	L
CKJNL 3225 P 16	32	25	32	32	170	34	1	-5	1.06	GI067	L



GI066

KN.X 1604...R

GI067

KN.X 1604...L



L

KNN 190412L

NT 03

–

UP 26

US 83

6.0

PR 07

K 23

HXK 4

L1

KNN 190412L

NT 03

–

UP 26

US 83

6.0

PR 07

K 22

HXK 4

R

KNN 190412R

NT 03

UP 25

–

US 83

6.0

PR 07

K 23

HXK 4

R1

KNN 190412R

NT 03

UP 25

–

US 83

6.0

PR 07

K 22

HXK 4



LN

40/ 50

KARBÜR UÇLAR

LNUX 40, LN.X 50



289

DOĞRU BOYUTLA EŞLEŞTİRİN (örnek)

Kesici uç

LNUX 40-1129003

Takım Tutucu

KHP-LBNR 40-A

ISO TORNALAMA - DIŞ

PLBN(RL) EXT

75°

LN..



40

50

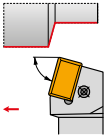

60×60

290

289

ISO TORNALAMA - AĞIR KABA - DIŞ

KHP-LBNR + DKH(RL)

75°

LN..



40

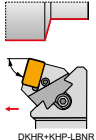

DKHR+KHP-LBNR

40×50
60×80

291, 292

289

KHP-LBNL + DKH(RL)

75°

LN..



40

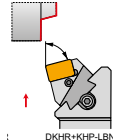

DKHR+KHP-LBNL

40×50
60×80

291, 292

289



LNUX 40, LN.X 50

	W1 (mm)	D1 (mm)	L (mm)	S (mm)
40-1	25.200	9.30	40.00	14.00
50-1	25.400	9.30	50.80	14.00
50-2	25.400	6.45	50.80	14.00
5014	25.400	6.35	50.80	14.00

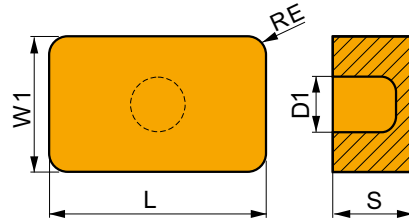

Kesme hızı (vc), ilerleme (f) ve kesme derinliği (ap) için uygunluk ve başlangıç değerleri. Daha ileri hesaplamalar için İşleme Hesaplayıcısı uygulamasına başvurun.

Product	RE (mm)	P			M			K			N			S			H		
		vc (m/min)	f (mm/rev)	ap (mm)	vc (m/min)	f (mm/rev)	ap (mm)	vc (m/min)	f (mm/rev)	ap (mm)	vc (m/min)	f (mm/rev)	ap (mm)	vc (m/min)	f (mm/rev)	ap (mm)	vc (m/min)	f (mm/rev)	ap (mm)

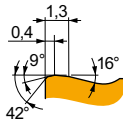

Ağır kaba işleme ve darbesizden darbeli kesmeye kadar uygun.

LNUX 40-1129002	T9226	3.2	45	1.35	25.0	–	–	–	40	1.35	25.0	–	–	–	–	–	–	–	–
	T9325	3.2	55	1.35	25.0	–	–	–	50	1.35	25.0	–	–	–	–	–	–	–	–
	T9335	3.2	40	1.35	25.0	–	–	–	–	–	–	–	–	–	–	–	–	–	–

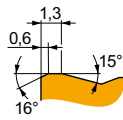

Ağır kaba işleme ve darbesizden darbeli kesmeye kadar uygun.

LNUX 40-1129003	T9226	3.2	45	1.35	25.0	–	–	–	40	1.35	25.0	–	–	–	–	–	–	–	–
	T9325	3.2	55	1.35	25.0	–	–	–	50	1.35	25.0	–	–	–	–	–	–	–	–
	T9335	3.2	40	1.35	25.0	–	–	–	–	–	–	–	–	–	–	–	–	–	–

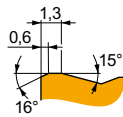

Ağır kaba işleme ve darbesizden darbeli kesmeye kadar uygun.

LNUX 50-1275000	T9226	3.2	45	1.35	25.0	–	–	–	40	1.35	25.0	–	–	–	–	–	–	–	–
	T9325	3.2	55	1.35	25.0	–	–	–	50	1.35	25.0	–	–	–	–	–	–	–	–

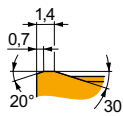

Ağır kaba işleme, darbesizden ağır darbeli kesmeye kadar uygun.

LNMX 501432E	T9335	3.2	45	1.50	25.0	–	–	–	–	–	–	–	–	–	–	–	–	–	–
--------------	-------	-----	----	------	------	---	---	---	---	---	---	---	---	---	---	---	---	---	---

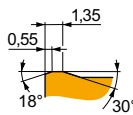

Ağır kaba işleme ve darbesizden darbeli kesmeye kadar uygun.

LNMX 50-2284000	T9315	3.2	60	1.50	25.0	–	–	–	55	1.50	25.0	–	–	–	–	–	–	–	–
-----------------	-------	-----	----	------	------	---	---	---	----	------	------	---	---	---	---	---	---	---	---



PLBN(RL) EXT



PRAMET

P



LNUX Uç için Levveli 75° Açılı Ağır Tornalama Dış Kater

Levveli, 75° açılı Sağ/Sol dış ağır tornalama kateri. Negatif LN.. 40ve 50 uçlarla çap, konik ve pah tornalamak için uygundur. 60x60 kadar mevcuttur. Gövde uzun takım ömrü için işlem görmüştür.

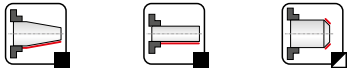
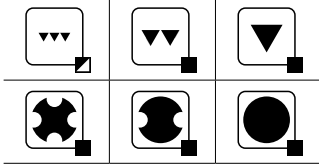
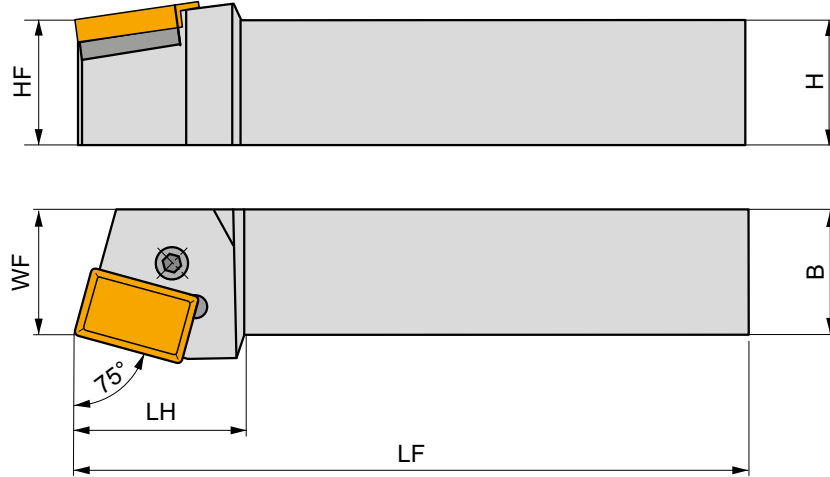
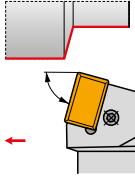

Product	H	B	HF	WF	LF	LH	LAMS	GAMO	kg		
	(mm)	(mm)	(mm)	(mm)	(mm)	(mm)	(°)	(°)			
R PLBNR 6060 V 40-A	60	60	60	60	400	64	-6	-6	13.00	GI102	PL71
PLBNR 6060 V 50	60	60	60	60	400	70	-6	-6	12.75	GI145	PL72
PLBNR 6060 V 50-2	60	60	60	60	400	70	-6	-6	11.60	GI291	PL73
L PLBNL 6060 V 40-A	60	60	60	60	400	64	-6	-6	11.14	GI102	PL71
PLBNL 6060 V 50	60	60	60	60	400	70	-6	-6	13.09	GI145	PL72



GI102
GI145
GI291

LNUX 40....
LNUX 50....
LNMX 50....



PL71	LNX 400632	PU 06	PS 12040	8.0	M 12x1	40	NT 08	MT 08	HXK 5	-	-
PL72	LNX 500632	PU 06	PS 12040	8.0	M 12x1	40	NT 08	MT 08	HXK 5	-	-
PL73	LNX 500432P	-	-	-	-	-	-	-	-	UP 1515A-T15P	SDRT15P



KHP-LBN(RL)



PRAMET

P



Modüler KHP Levyeleli Torna Kartuşu, 75° Kesme Açılı, LNUX Uç için

DKH takım tutucu şaft için kırılmaç bağlantılı, 75° açılı Sağ/Sol levyeleli kartuş. LNUX 40 uçlarla çap, alın, konik ve pah tornalamak için uygundur. Tutucu uzun takım ömrü için işlem görmüştür.

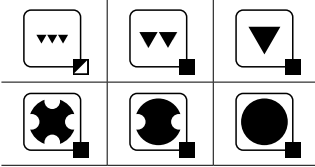
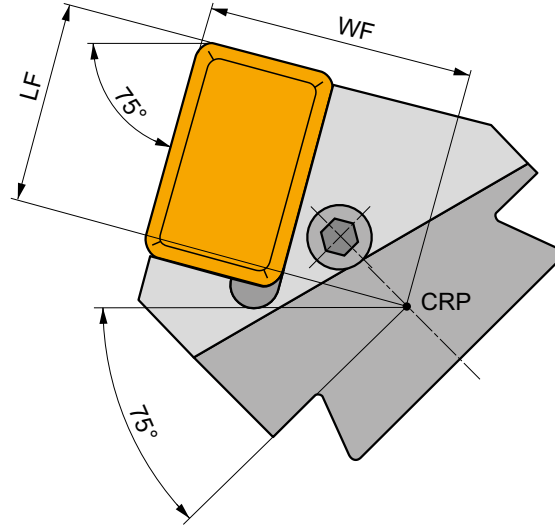
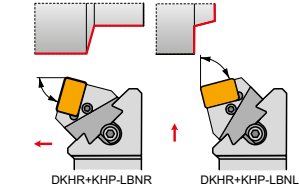

Product

WF

LF

LAMS

GAMO

kg



(mm)

(mm)

(°)

(°)

GI102

PL71

L

KHP-LBNR 40-A

48

36

-6

-6

1.50

GI102

PL71

KHP-LBNL 40-A

48

36

-6

-6

1.47

GI102

PL71



GI102



LNUX 40....



PL71



LNX 400632



PU 06



PS 12040



8.0



M 12x1



40



NT 08



MT 08



HXK 5



DKH(RL)



KHP/KHS Ağır Tornalama Kartuşları için Dış Kater Şaftı

KHP/KHS kartuşlar için kırılmalı Sağ/Sol takım şaftı. Ağır tornalama için uygundur. 40x50'den 60x80mm'ye kadar mevcut. Gövde uzun takım ömrü için işlem görmüştür.

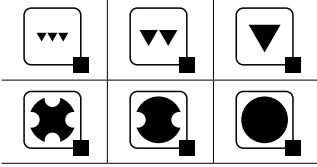
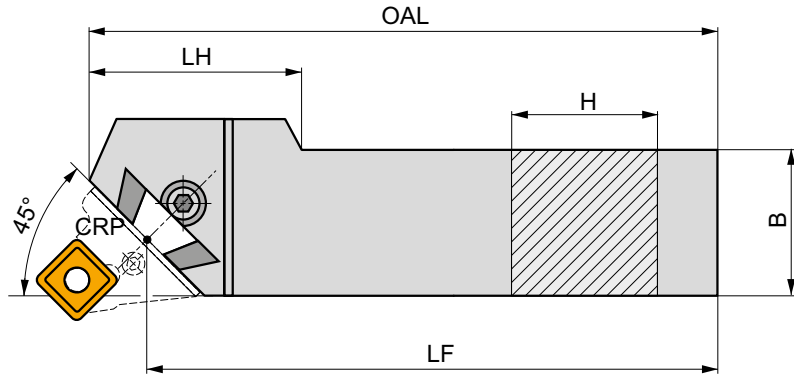
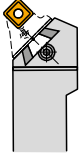

	Product	H	B	LF	OAL	LH	kg		
		(mm)	(mm)	(mm)	(mm)	(mm)			
R	DKHR 4050 V	40	50	400	425	100	7.10	GI098	DKH10
	DKHR 5060 W	50	60	450	475	110	11.30	GI098	DKH10
	DKHR 6080 W-A	60	80	450	485	90	19.65	GI098	DKH10
L	DKHL 4050 V	40	50	400	425	100	7.10	GI098	DKH10
	DKHL 5060 W	50	60	450	475	110	11.30	GI098	DKH10
	DKHL 6080 W-A	60	80	450	485	90	19.28	GI098	DKH10



GI098



KHP



KHS



DKH10



SR 14



HXK 10



RN

09/ 12/ 15/ 19/ 25

KARBÜR UÇLAR

RNMG



294

CER UÇLAR

RNGN CER



294

DOĞRU BOYUTLA EŞLEŞTİRİN (örnek)

Kesici uç

RNMG 120400E-08

Takım Tutucu

DRSNR 2525 M 12

ISO TORNALAMA - DIŞ

DRSN(RL) EXT

RN..



12

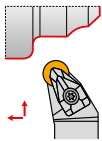

25x25

295

294

PRSN(RL) EXT

RN..



12

15

19

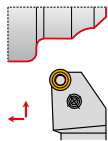

25x25
40x40

296

294

C.-DRSN(RL) EXT **NEW**

RN..



12

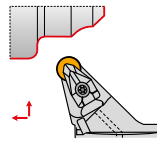

C6

297

294



RNMG

	INSD (mm)	D1 (mm)	S (mm)
1204	12.700	5.16	4.76
1506	15.875	6.35	6.35
1906	19.050	7.94	6.35
2509	25.400	9.12	9.53

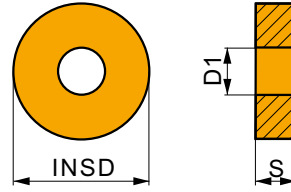

Kesme hızı (vc), ilerleme (f) ve kesme derinliği (ap) için uygunluk ve başlangıç değerleri. Daha ileri hesaplamalar için İşleme Hesaplayıcısı uygulamasına başvurun.

Product	RE	P			M			K			N			S			H		
		vc (m/min)	f (mm/rev)	ap (mm)	vc (m/min)	f (mm/rev)	ap (mm)	vc (m/min)	f (mm/rev)	ap (mm)	vc (m/min)	f (mm/rev)	ap (mm)	vc (m/min)	f (mm/rev)	ap (mm)	vc (m/min)	f (mm/rev)	ap (mm)

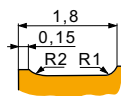

Geometri 08, yarı kabadan ağır kaba işlemeye kadar, ve darbesizden darbeli kesime kadar uygun.

RNMG 120400E-08	T5305	-	✓	195	0.70	3.0	-	-	-	✓	185	0.70	3.0	-	-	-	-	-	-	✓	35	0.15	1.0
	T9315	-	✓	150	0.70	3.0	-	-	-	✓	140	0.70	3.0	-	-	-	-	-	-	✓	30	0.15	1.0
	T9325	-	✓	135	0.70	3.0	-	-	-	✓	125	0.70	3.0	-	-	-	-	-	-	-	-	-	-
RNMG 150600E-08	T5305	-	✓	295	0.70	3.0	-	-	-	✓	280	0.70	3.0	-	-	-	-	-	-	✓	55	0.15	1.0
	T9315	-	✓	225	0.70	3.0	-	-	-	✓	210	0.70	3.0	-	-	-	-	-	-	✓	45	0.15	1.0
	T9325	-	✓	205	0.70	3.0	-	-	-	✓	190	0.70	3.0	-	-	-	-	-	-	-	-	-	-
RNMG 190600E-08	T9315	-	✓	150	0.70	3.0	-	-	-	✓	140	0.70	3.0	-	-	-	-	-	-	✓	30	0.15	1.0
	T9325	-	✓	135	0.70	3.0	-	-	-	✓	125	0.70	3.0	-	-	-	-	-	-	-	-	-	-

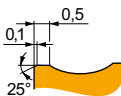

Geometri 081, kabadan ağır kaba işlemeye kadar, ve darbesizden darbeli kesime kadar uygun.

RNMG 250900E-081	T9315	-	✓	145	0.90	5.0	-	-	-	✓	135	0.90	5.0	-	-	-	-	-	✓	25	0.15	1.0
	T9325	-	✓	130	0.90	5.0	-	-	-	✓	120	0.90	5.0	-	-	-	-	-	-	-	-	-

RNGN CER

	INSD (mm)	S (mm)
0903	9.525	3.18
1204	12.700	4.76
1207	12.700	7.94

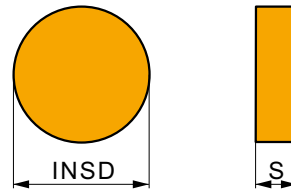

Kesme hızı (vc), ilerleme (f) ve kesme derinliği (ap) için uygunluk ve başlangıç değerleri. Daha ileri hesaplamalar için İşleme Hesaplayıcısı uygulamasına başvurun.

Product	RE	P			M			K			N			S			H		
		vc (m/min)	f (mm/rev)	ap (mm)	vc (m/min)	f (mm/rev)	ap (mm)	vc (m/min)	f (mm/rev)	ap (mm)	vc (m/min)	f (mm/rev)	ap (mm)	vc (m/min)	f (mm/rev)	ap (mm)	vc (m/min)	f (mm/rev)	ap (mm)

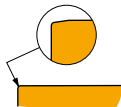

Yüksek hızlı işleme ve darbesiz kesme için.

RNGN 090300 T01020	TC100	-	-	-	-	-	-	-	-	✓	460	0.20	1.2	-	-	-	-	-	-	-	-	-	-
RNGN 120400 T01020	TC100	-	-	-	-	-	-	-	-	✓	455	0.20	1.5	-	-	-	-	-	-	-	-	-	-
RNGN 120700 T01020	TC100	-	-	-	-	-	-	-	-	✓	455	0.20	1.5	-	-	-	-	-	-	-	-	-	-
RNGN 120700 T15015	TC100	-	-	-	-	-	-	-	-	✓	455	0.20	1.5	-	-	-	-	-	-	-	-	-	-



DRSN(RL) EXT



PRAMET

D

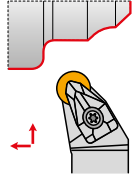

RN.. Uç için Çift Sıklı Dış Kateri

Çift sıklı Sağ/Sol dış kater. Negatif RN.. 12 uçlarla çap, kopya, konik ve pah tornalama için uygundur. Sadece 25x25mm. Gövde uzun takım ömrü için işlem görmüştür.

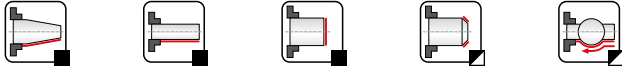
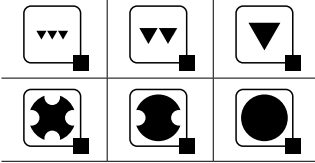
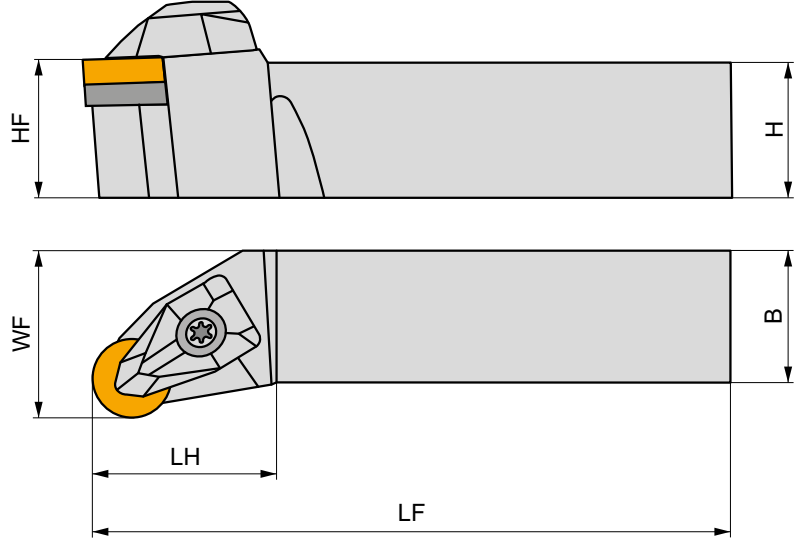

Product	H	B	HF	WF	LF	LH	LAMS	GAMO	kg	GI083	DR12
	(mm)	(mm)	(mm)	(mm)	(mm)	(mm)	(°)	(°)			
R DRSNR 2525 M 12	25	25	25	32	150	31.6	-6	-6	0.74	GI083	DR12
L DRSNL 2525 M 12	25	25	25	32	150	31.6	-6	-6	0.75	GI083	DR12



GI083



RN.. 120400



DR12



DCS 12



3.9



DRS 155-02



US 2002-T15P



FLAG T15P/3,5



PRSN(RL) EXT



PRAMET

P



RN.. UÇ İÇİN Levveli Dış Kater

Levveli, 90° açılı Sağ/Sol dış kater. Negatif RN.. 12, 15 ve 19 uçlarla çap, 90° kopya, konik ve pah tormalamak için uygundur. 25x25'den 40x40mm'ye kadar mevcuttur. Gövde uzun takım ömrü için işlem görmüştür.

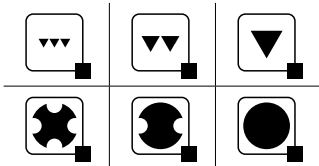
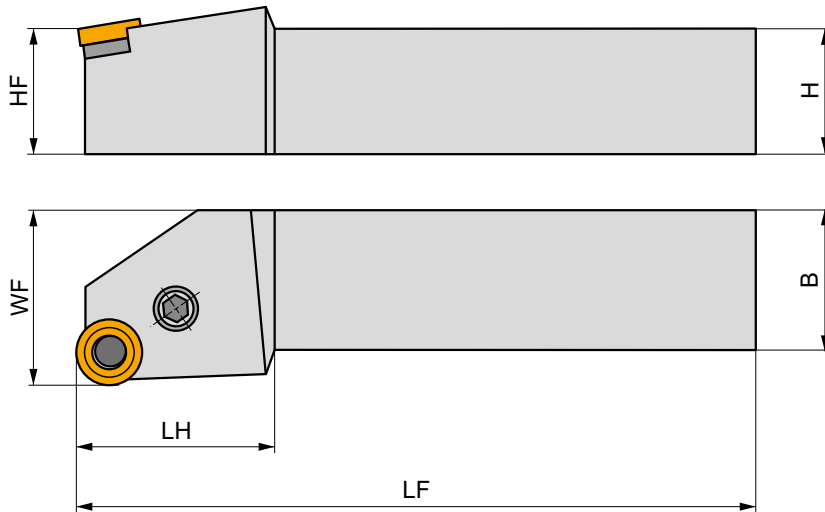
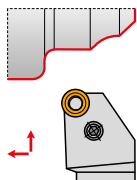

Product	H	B	HF	WF	LF	LH	LAMS	GAMO	kg		
	(mm)	(mm)	(mm)	(mm)	(mm)	(mm)	(°)	(°)			
R PRSNR 2525 M 12	25	25	25	32	150	32	-6	-6	0.68	GI083	PR20
PRSNR 3232 P 15	32	32	32	40	170	38	-6	-6	1.40	GI105	PR40
PRSNR 4040 R 19	40	40	40	50	200	40	-6	-6	2.49	GI106	PR50
L PRSNL 2525 M 12	25	25	25	32	150	32	-6	-6	0.74	GI083	PR20
PRSNL 3232 P 15	32	32	32	40	170	38	-6	-6	1.40	GI105	PR40
PRSNL 4040 R 19	40	40	40	50	200	40	-6	-6	2.48	GI106	PR50



GI083

RN.. 120400

GI105

RN.. 150600

GI106

RN.. 190600



PR20

RNU 120300

PU 02

US 35

6.0

M 8x1

22.5

NT 05

MT 05

HXK 4

PR40

RNU 150300

PU 04

US 36

6.0

M 8x1

26

NT 07

MT 07

HXK 4

PR50

RNU 190400

PU 05

US 38

8.0

M 10x1

29

NT 06

MT 06

HXK 5

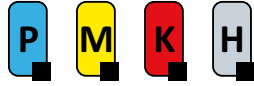
NEW
C.-DRSN(RL) EXT

PRAMET
D

RN.. Uç için Çift Sıklımlı, Hızlı Değişirme Dış Takımı

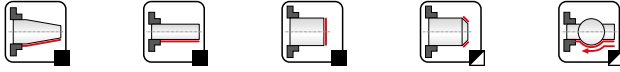
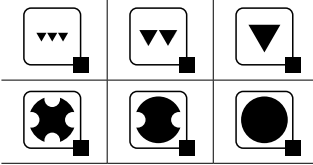
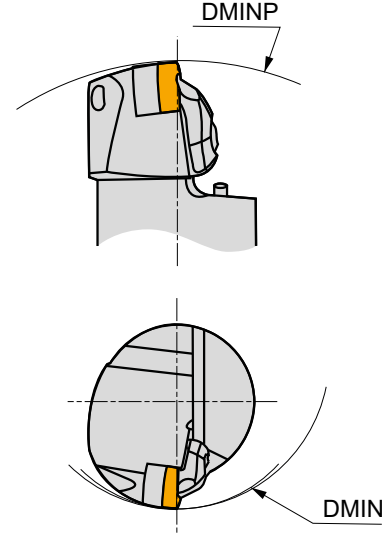
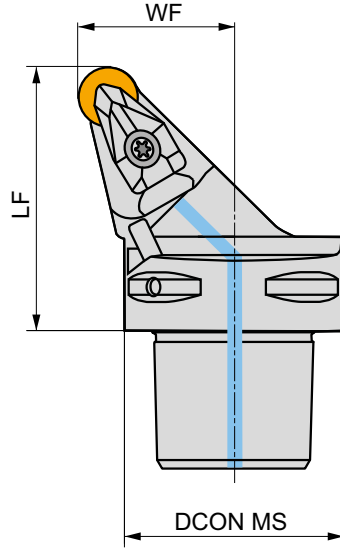
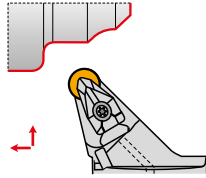
Çift sıklımlı, açılı, içten su vermeli Sağ/Sol dış kater. Negatif RN.. 12 uçlarla çap, alın, konik ve pah tornalamak için uygundur. C6 PSC şaftlı mevcuttur. Tutucu uzun takım ömrü için işlem görmüştür.



Product	DCON MS (mm)	DMIN (mm)	DMINP (mm)	WF (mm)	LF (mm)	LAMS (°)	GAMO (°)					
R C6-DRSNR-45065-12	63	110	190	45	65	-6	-6	✓	1.11	GI083	C-DR12	-
L C6-DRSNL-45065-12	63	110	190	45	65	-6	-6	✓	1.10	GI083	C-DR12	-



GI083



RN.. 120400



C-DR12



DCS 12



3.9



DRS 155-02



US 2002-T15P



FLAG T15P/3,5



CN 045-01



SN

09/ 12/ 15/ 19/ 25

KARBÜR UÇLAR

SNMA	SNMG	SNMM	SNMX
300	301	307	311

CER UÇLAR

SNGA CER	SNGN CER
311	312

DOĞRU BOYUTLA EŞLEŞTİRİN (örnek)

Kesici uç	Takım Tutucu
SNMG 190616E-RM	DSDNN 3232 P 19

ISO TORNALAMA - DIŞ

<p>DSBN(RL) EXT</p> <p>75°</p> <p>SN..</p> <p>12 15 19</p> <p>20×20 40×40</p> <p> 313</p> <p> 300 – 312</p>	<p>DSDNN EXT</p> <p>45°</p> <p>SN..</p> <p>12 15 19 25</p> <p>20×20 40×40</p> <p> 315</p> <p> 300 – 312</p>	<p>DSKN(RL) EXT</p> <p>75°</p> <p>SN..</p> <p>12 19</p> <p>25×25 32×32</p> <p> 316</p> <p> 300 – 312</p>	<p>DSSN(RL) EXT</p> <p>45°</p> <p>SN..</p> <p>12 15 19</p> <p>20×20 40×40</p> <p> 317</p> <p> 300 – 312</p>
<p>PSBN(RL) EXT</p> <p>75°</p> <p>SN..</p> <p>12 15 19 25</p> <p>20×20 50×50</p> <p> 318</p> <p> 300 – 312</p>	<p>PSDNN EXT</p> <p>45°</p> <p>SN..</p> <p>12 15 19 25</p> <p>20×20 50×50</p> <p> 320</p> <p> 300 – 312</p>	<p>PSKN(RL) EXT</p> <p>75°</p> <p>SN..</p> <p>12 15 19 25</p> <p>20×20 50×50</p> <p> 321</p> <p> 300 – 312</p>	<p>PSSN(RL) EXT</p> <p>45°</p> <p>SN..</p> <p>19 25</p> <p>40×40 50×50</p> <p> 323</p> <p> 300 – 312</p>



SN

09/ 12/ 15/ 19/ 25

C.-DSDNN EXT **NEW**

45°		SN..
12 19		
	$\frac{C4}{C6}$	
324	300 – 312	

C.-DSKN(RL) EXT **NEW**

75°		SN..
12		
	C4	
325	300 – 312	

C.-DSRN(RL) EXT **NEW**

75°		SN..
12 19		
	$\frac{C4}{C6}$	
326	300 – 312	

C.-DSSN(RL) EXT **NEW**

45°		SN..
12		
	$\frac{C4}{C5}$	
327	300 – 312	

ISO TORNALAMA - AĞIR KABA - DIŞ

KHP-SBNR + DKH(RL)

75°		SN..
25		
	$\frac{40 \times 50}{60 \times 80}$	
328, 330	300 – 312	

KHP-SBNL + DKH(RL)

75°		SN..
25		
	$\frac{40 \times 50}{60 \times 80}$	
328, 330	300 – 312	

KHP-SSNR/L + DKH(RL)

45°		SN..
19 25		
	$\frac{40 \times 50}{60 \times 80}$	
329, 330	300 – 312	

ISO TORNALAMA - İÇ

PSKN(RL) INT

93°		SN..
11 15		
	$\frac{32}{80}$	
331	300 – 312	



SNMA

	IC	D1	L	S
	(mm)	(mm)	(mm)	(mm)
1204	12.700	5.16	12.70	4.76
1506	15.875	6.35	15.875	6.35
1906	19.050	7.94	19.05	6.35
2507	25.400	9.12	25.40	7.94
2509	25.400	9.12	25.40	9.525

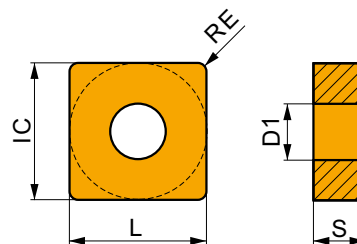

Kesme hızı (vc), ilerleme (f) ve kesme derinliği (ap) için uygunluk ve başlangıç değerleri. Daha ileri hesaplamalar için İşleme Hesaplayıcısı uygulamasına başvurun.

Product	RE	P			M			K			N			S			H		
		vc	f	ap	vc	f	ap	vc	f	ap	vc	f	ap	vc	f	ap	vc	f	ap
	(mm)	(m/min)	(mm/rev)	(mm)	(m/min)	(mm/rev)	(mm)	(m/min)	(mm/rev)	(mm)	(m/min)	(mm/rev)	(mm)	(m/min)	(mm/rev)	(mm)	(m/min)	(mm/rev)	(mm)

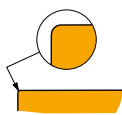

İnce finişten yarı kaba işleme kadar ve darbesizden hafif darbeli kesmeye kadar uygun.

SNMA 120408	T5305	0.8	-	-	-	-	-	-	230	0.20	4.0	-	-	-	-	-	-	45	0.15	1.0
	T5315	0.8	-	-	-	-	-	-	200	0.20	4.0	-	-	-	-	-	-	40	0.15	1.0
	T6310	0.8	-	-	-	-	-	-	100	0.20	4.0	-	-	-	-	-	-	25	0.15	1.0
SNMA 120412	T5305	1.2	-	-	-	-	-	-	205	0.30	4.0	-	-	-	-	-	-	40	0.15	1.0
	T5315	1.2	-	-	-	-	-	-	190	0.30	4.0	-	-	-	-	-	-	40	0.15	1.0
SNMA 150612	T5305	1.2	-	-	-	-	-	-	200	0.30	5.0	-	-	-	-	-	-	40	0.15	1.0
	T5315	1.2	-	-	-	-	-	-	185	0.30	5.0	-	-	-	-	-	-	35	0.15	1.0
SNMA 190612	T5305	1.2	-	-	-	-	-	-	195	0.30	6.0	-	-	-	-	-	-	40	0.15	1.0
	T5315	1.2	-	-	-	-	-	-	180	0.30	6.0	-	-	-	-	-	-	35	0.15	1.0
SNMA 190616	T5305	1.6	-	-	-	-	-	-	190	0.40	6.0	-	-	-	-	-	-	40	0.15	1.0
	T5315	1.6	-	-	-	-	-	-	170	0.40	6.0	-	-	-	-	-	-	35	0.15	1.0
SNMA 250724	T5305	2.4	-	-	-	-	-	-	95	0.60	8.0	-	-	-	-	-	-	20	0.15	1.0
	T5315	2.4	-	-	-	-	-	-	90	0.60	8.0	-	-	-	-	-	-	15	0.15	1.0
SNMA 250924	T5305	2.4	-	-	-	-	-	-	95	0.60	8.0	-	-	-	-	-	-	20	0.15	1.0
	T5315	2.4	-	-	-	-	-	-	90	0.60	8.0	-	-	-	-	-	-	15	0.15	1.0

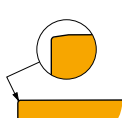

İnce finişten yarı kaba işleme kadar ve darbesizden hafif darbeli kesmeye kadar uygun.

SNMA 120412S	T5305	1.2	-	-	-	-	-	-	205	0.30	4.0	-	-	-	-	-	-	40	0.15	1.0
SNMA 190616S	T5305	1.6	-	-	-	-	-	-	195	0.30	6.0	-	-	-	-	-	-	40	0.15	1.0
SNMA 250724S	T5305	2.4	-	-	-	-	-	-	95	0.60	8.0	-	-	-	-	-	-	20	0.15	1.0
SNMA 250924S	T5305	2.4	-	-	-	-	-	-	95	0.60	8.0	-	-	-	-	-	-	20	0.15	1.0



SNMG

	IC (mm)	D1 (mm)	L (mm)	S (mm)
1204	12.700	5.16	12.70	4.76
1506	15.875	6.35	15.875	6.35
1906	19.050	7.94	19.05	6.35
2507	25.400	9.12	25.40	7.94
2509	25.400	9.12	25.40	9.525

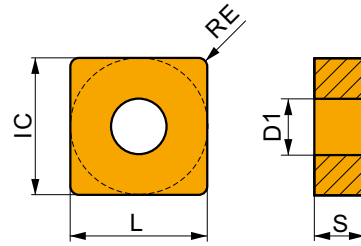

Kesme hızı (vc), ilerleme (f) ve kesme derinliği (ap) için uygunluk ve başlangıç değerleri. Daha ileri hesaplamalar için İşleme Hesaplayıcısı uygulamasına başvurun.

Product	RE (mm)	P			M			K			N			S			H		
		vc (m/min)	f (mm/rev)	ap (mm)	vc (m/min)	f (mm/rev)	ap (mm)	vc (m/min)	f (mm/rev)	ap (mm)	vc (m/min)	f (mm/rev)	ap (mm)	vc (m/min)	f (mm/rev)	ap (mm)	vc (m/min)	f (mm/rev)	ap (mm)

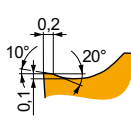

FM pozitif geometri, finişten yarı kaba işleme, ve darbesizden hafif darbeleri kesmeye kadar uygun.

SNMG 120404E-FM	T6310	0.4	175	0.20	2.1	125	0.18	2.1	140	0.20	2.1	-	-	-	50	0.14	1.7	-	-	-
	T7325	0.4	195	0.20	2.1	150	0.18	2.1	-	-	-	-	-	-	60	0.16	1.7	-	-	-
	T8315	0.4	180	0.20	2.1	105	0.18	2.1	170	0.20	2.1	-	-	-	45	0.14	1.7	-	-	-
	T8330	0.4	175	0.20	2.1	105	0.18	2.1	165	0.20	2.1	-	-	-	40	0.14	1.7	-	-	-
	T8430	0.4	195	0.20	2.1	105	0.18	2.1	160	0.20	2.1	-	-	-	40	0.14	1.7	-	-	-
	T9315	0.4	270	0.20	2.1	-	-	-	255	0.20	2.1	-	-	-	-	-	-	-	-	-
SNMG 120408E-FM	T9325	0.4	240	0.20	2.1	140	0.18	2.1	225	0.20	2.1	-	-	-	50	0.16	1.7	-	-	-
	T7325	0.8	235	0.20	2.1	180	0.18	2.1	-	-	-	-	-	-	75	0.16	1.7	-	-	-
	T8315	0.8	215	0.20	2.1	125	0.18	2.1	200	0.20	2.1	-	-	-	50	0.16	1.7	-	-	-
	T8330	0.8	205	0.20	2.1	120	0.18	2.1	190	0.20	2.1	-	-	-	50	0.16	1.7	-	-	-
	T8430	0.8	235	0.20	2.1	125	0.18	2.1	190	0.20	2.1	-	-	-	50	0.16	1.7	-	-	-
	T9310	0.8	355	0.20	2.1	-	-	-	335	0.20	2.1	-	-	-	-	-	-	-	-	-
SNMG 120412E-FM	T9315	0.8	320	0.20	2.1	-	-	-	300	0.20	2.1	-	-	-	-	-	-	-	-	-
	T9325	0.8	290	0.20	2.1	170	0.18	2.1	275	0.20	2.1	-	-	-	65	0.16	1.7	-	-	-
	T8330	1.2	200	0.27	2.1	120	0.24	2.1	190	0.27	2.1	-	-	-	50	0.19	1.7	-	-	-
	T8430	1.2	220	0.27	2.1	120	0.24	2.1	180	0.27	2.1	-	-	-	45	0.19	1.7	-	-	-
SNMG 120416E-FM	T9315	1.2	300	0.27	2.1	-	-	-	285	0.27	2.1	-	-	-	-	-	-	-	-	-
	T9325	1.2	270	0.27	2.1	160	0.24	2.1	255	0.27	2.1	-	-	-	60	0.19	1.7	-	-	-
	T8330	1.6	200	0.32	2.1	120	0.29	2.1	190	0.32	2.1	-	-	-	50	0.22	1.7	-	-	-
SNMG 120416E-FM	T8430	1.6	220	0.32	2.1	120	0.29	2.1	180	0.32	2.1	-	-	-	45	0.22	1.7	-	-	-
	T9325	1.6	260	0.32	2.1	155	0.29	2.1	245	0.32	2.1	-	-	-	55	0.22	1.7	-	-	-

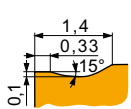

KR geometri, yarı kabadan kaba işleme kadar, darbesizden darbeleri kesmeye kadar uygun.

SNMG 120408E-KR	T5305	0.8	265	0.35	3.8	-	-	-	250	0.35	3.8	-	-	-	-	-	-	50	0.15	1.0
	T5315	0.8	235	0.35	3.8	-	-	-	220	0.35	3.8	-	-	-	-	-	-	45	0.15	1.0
SNMG 120412E-KR	T5305	1.2	265	0.40	3.8	-	-	-	250	0.40	3.8	-	-	-	-	-	-	50	0.15	1.0
	T5315	1.2	240	0.40	3.8	-	-	-	225	0.40	3.8	-	-	-	-	-	-	45	0.15	1.0

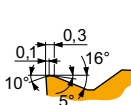

M geometri, finişten yarı kaba işleme kadar ve darbesizden darbeleri kesmeye kadar uygun.

SNMG 120408E-M	T5305	0.8	290	0.32	2.1	-	-	-	275	0.32	2.1	-	-	-	-	-	-	55	0.15	1.0
	T5315	0.8	260	0.32	2.1	-	-	-	245	0.32	2.1	-	-	-	-	-	-	50	0.15	1.0
	T9310	0.8	255	0.32	2.1	-	-	-	240	0.32	2.1	-	-	-	-	-	-	50	0.15	1.0
	T9315	0.8	235	0.32	2.1	-	-	-	220	0.32	2.1	-	-	-	-	-	-	45	0.15	1.0
	T9325	0.8	210	0.32	2.1	-	-	-	195	0.32	2.1	-	-	-	-	-	-	-	-	-
	T9335	0.8	185	0.32	2.1	-	-	-	-	-	-	-	-	-	-	-	-	-	-	-



Kesme hızı (vc), ilerleme (f) ve kesme derinliği (ap) için uygunluk ve başlangıç değerleri. Daha ileri hesaplamalar için İşleme Hesaplayıcısı uygulamasına başvurun.

Product	RE (mm)	P			M			K			N			S			H		
		vc (m/min)	f (mm/rev)	ap (mm)	vc (m/min)	f (mm/rev)	ap (mm)	vc (m/min)	f (mm/rev)	ap (mm)	vc (m/min)	f (mm/rev)	ap (mm)	vc (m/min)	f (mm/rev)	ap (mm)	vc (m/min)	f (mm/rev)	ap (mm)

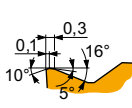

M geometri, finişten yarı kaba işleme kadar ve darbesizden darbeli kesime kadar uygun.

SNMG 120412E-M	T9315	1.2	230	0.40	2.1	-	-	-	215	0.40	2.1	-	-	-	-	-	-	45	0.15	1.0
	T9325	1.2	200	0.40	2.1	-	-	-	190	0.40	2.1	-	-	-	-	-	-	-	-	-
	T9335	1.2	175	0.40	2.1	-	-	-	-	-	-	-	-	-	-	-	-	-	-	-
SNMG 120416E-M	T9325	1.6	210	0.40	2.1	-	-	-	195	0.40	2.1	-	-	-	-	-	-	-	-	-
SNMG 150612E-M	T9315	1.2	220	0.40	3.4	-	-	-	205	0.40	3.4	-	-	-	-	-	-	40	0.15	1.0
	T9325	1.2	195	0.40	3.4	-	-	-	185	0.40	3.4	-	-	-	-	-	-	-	-	-
	T9335	1.2	170	0.40	3.4	-	-	-	-	-	-	-	-	-	-	-	-	-	-	-
SNMG 190612E-M	T9315	1.2	215	0.40	4.0	-	-	-	200	0.40	4.0	-	-	-	-	-	-	40	0.15	1.0
	T9325	1.2	190	0.40	4.0	-	-	-	180	0.40	4.0	-	-	-	-	-	-	-	-	-
	T9335	1.2	165	0.40	4.0	-	-	-	-	-	-	-	-	-	-	-	-	-	-	-
SNMG 190616E-M	T9315	1.6	225	0.40	4.0	-	-	-	210	0.40	4.0	-	-	-	-	-	-	45	0.15	1.0
	T9325	1.6	200	0.40	4.0	-	-	-	190	0.40	4.0	-	-	-	-	-	-	-	-	-
	T9335	1.6	175	0.40	4.0	-	-	-	-	-	-	-	-	-	-	-	-	-	-	-

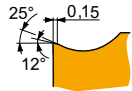

NF geometri, ince finişten orta kabaya kadar işlemek için çok pozitif tasarım, darbesiz kesim için uygun.

SNMG 120404E-NF	T6310	0.4	185	0.17	1.7	130	0.15	1.7	145	0.17	1.7	555	0.20	1.7	55	0.14	1.4	-	-	-
	T7325	0.4	210	0.18	1.7	160	0.16	1.7	-	-	-	-	-	-	65	0.16	1.4	-	-	-
	T7335	0.4	205	0.18	1.7	155	0.16	1.7	-	-	-	-	-	-	65	0.16	1.4	-	-	-
	T8330	0.4	185	0.17	1.7	110	0.15	1.7	175	0.17	1.7	555	0.20	1.7	45	0.14	1.4	-	-	-
	T8430	0.4	210	0.17	1.7	115	0.15	1.7	175	0.17	1.7	585	0.20	1.7	45	0.14	1.4	-	-	-
	T9315	0.4	300	0.17	1.7	-	-	-	285	0.17	1.7	-	-	-	-	-	-	-	-	-
	T9325	0.4	260	0.18	1.7	155	0.16	1.7	245	0.18	1.7	-	-	-	55	0.16	1.4	-	-	-
	SNMG 120408E-NF	HF7	0.8	-	-	-	120	0.17	1.7	190	0.19	1.7	600	0.23	1.7	-	-	-	-	-
T6310		0.8	210	0.19	1.7	150	0.17	1.7	165	0.19	1.7	630	0.23	1.7	60	0.15	1.4	-	-	-
T7325		0.8	245	0.19	1.7	190	0.17	1.7	-	-	-	-	-	-	75	0.15	1.4	-	-	-
T7335		0.8	240	0.19	1.7	185	0.17	1.7	-	-	-	-	-	-	75	0.15	1.4	-	-	-
T8315		0.8	230	0.19	1.7	135	0.17	1.7	215	0.19	1.7	690	0.23	1.7	55	0.15	1.4	-	-	-
T8330		0.8	210	0.19	1.7	125	0.17	1.7	195	0.19	1.7	630	0.23	1.7	50	0.15	1.4	-	-	-
T8430		0.8	250	0.19	1.7	135	0.17	1.7	205	0.19	1.7	690	0.23	1.7	50	0.15	1.4	-	-	-
T9315		0.8	340	0.19	1.7	-	-	-	320	0.19	1.7	-	-	-	-	-	-	-	-	-
T9325	0.8	300	0.19	1.7	180	0.17	1.7	285	0.19	1.7	-	-	-	65	0.15	1.4	-	-	-	

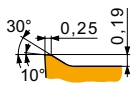

NM geometri, ince finiş, orta ve kaba işlemek için çok pozitif tasarım, darbesiz kesim için uygun.

SNMG 120408E-NM	T7325	0.8	225	0.25	2.1	175	0.23	2.1	-	-	-	-	-	-	70	0.20	1.7	-	-	-
	T7335	0.8	220	0.25	2.1	170	0.23	2.1	-	-	-	-	-	-	70	0.20	1.7	-	-	-
	T8315	0.8	215	0.25	2.1	125	0.23	2.1	-	-	-	645	0.30	2.1	50	0.20	1.7	-	-	-
	T8330	0.8	205	0.25	2.1	120	0.23	2.1	-	-	-	615	0.30	2.1	50	0.20	1.7	-	-	-
	T8430	0.8	225	0.25	2.1	120	0.23	2.1	-	-	-	615	0.30	2.1	45	0.20	1.7	-	-	-
SNMG 120412E-NM	T9325	0.8	275	0.25	2.1	165	0.23	2.1	-	-	-	-	-	-	60	0.20	1.7	-	-	-
	T7325	1.2	225	0.30	2.1	175	0.27	2.1	-	-	-	-	-	-	70	0.24	1.7	-	-	-
	T7335	1.2	220	0.30	2.1	170	0.27	2.1	-	-	-	-	-	-	70	0.24	1.7	-	-	-
	T8315	1.2	215	0.30	2.1	125	0.27	2.1	-	-	-	645	0.36	2.1	50	0.24	1.7	-	-	-
	T9325	1.2	270	0.30	2.1	160	0.27	2.1	-	-	-	-	-	-	60	0.24	1.7	-	-	-



Kesme hızı (vc), ilerleme (f) ve kesme derinliği (ap) için uygunluk ve başlangıç değerleri. Daha ileri hesaplamalar için İşleme Hesaplayıcısı uygulamasına başvurun.

Product	RE (mm)	P			M			K			N			S			H		
		vc (m/min)	f (mm/rev)	ap (mm)	vc (m/min)	f (mm/rev)	ap (mm)	vc (m/min)	f (mm/rev)	ap (mm)	vc (m/min)	f (mm/rev)	ap (mm)	vc (m/min)	f (mm/rev)	ap (mm)	vc (m/min)	f (mm/rev)	ap (mm)

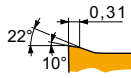

NMR geometri, ortadan kabaya kadar işlemek için pozitif tasarım, darbesiz kesim için uygun.

SNMG 120408E-NMR	T6310	0.8	■	155	0.35	2.6	■	110	0.32	2.6	■	-	-	-	■	45	0.25	2.1	-	-	-
	T7325	0.8	■	175	0.35	2.6	■	135	0.32	2.6	■	-	-	-	■	55	0.25	2.1	-	-	-
	T7335	0.8	■	165	0.35	2.6	■	125	0.32	2.6	■	-	-	-	■	50	0.25	2.1	-	-	-
	T8330	0.8	■	155	0.35	2.6	■	90	0.32	2.6	■	-	-	-	■	35	0.25	2.1	-	-	-
	T8430	0.8	■	165	0.35	2.6	■	90	0.32	2.6	■	-	-	-	■	35	0.25	2.1	-	-	-
	T9315	0.8	■	225	0.35	2.6	■	-	-	-	■	-	-	-	-	-	-	-	-	-	-
SNMG 120412E-NMR	T6310	1.2	■	160	0.40	2.6	■	115	0.36	2.6	■	-	-	-	■	45	0.28	2.1	-	-	-
	T7325	1.2	■	175	0.40	2.6	■	135	0.36	2.6	■	-	-	-	■	55	0.28	2.1	-	-	-
	T7335	1.2	■	165	0.40	2.6	■	125	0.36	2.6	■	-	-	-	■	50	0.28	2.1	-	-	-
	T9315	1.2	■	225	0.40	2.6	■	-	-	-	■	-	-	-	-	-	-	-	-	-	-
	T9325	1.2	■	200	0.40	2.6	■	120	0.36	2.6	■	-	-	-	■	45	0.28	2.1	-	-	-
SNMG 120416E-NMR	T7325	1.6	■	180	0.45	2.6	■	140	0.41	2.6	■	-	-	-	■	55	0.32	2.1	-	-	-
	T7335	1.6	■	170	0.45	2.6	■	130	0.41	2.6	■	-	-	-	■	55	0.32	2.1	-	-	-
	T9325	1.6	■	200	0.45	2.6	■	120	0.41	2.6	■	-	-	-	■	45	0.32	2.1	-	-	-
SNMG 150612E-NMR	T6310	1.2	■	150	0.40	3.8	■	105	0.36	3.8	■	-	-	-	■	45	0.28	3.0	-	-	-
	T7325	1.2	■	170	0.40	3.8	■	130	0.36	3.8	■	-	-	-	■	55	0.28	3.0	-	-	-
	T9315	1.2	■	215	0.40	3.8	■	-	-	-	■	-	-	-	-	-	-	-	-	-	-
	T9325	1.2	■	190	0.40	3.8	■	110	0.36	3.8	■	-	-	-	■	40	0.28	3.0	-	-	-
SNMG 190612E-NMR	T6310	1.2	■	145	0.40	5.2	■	100	0.36	5.2	■	-	-	-	■	40	0.28	4.2	-	-	-
	T7325	1.2	■	165	0.40	5.2	■	125	0.36	5.2	■	-	-	-	■	50	0.28	4.2	-	-	-
	T7335	1.2	■	155	0.40	5.2	■	120	0.36	5.2	■	-	-	-	■	50	0.28	4.2	-	-	-
	T9315	1.2	■	210	0.40	5.2	■	-	-	-	■	-	-	-	-	-	-	-	-	-	-
	T9325	1.2	■	185	0.40	5.2	■	110	0.36	5.2	■	-	-	-	■	40	0.28	4.2	-	-	-
SNMG 190616E-NMR	T6310	1.6	■	150	0.45	5.2	■	105	0.41	5.2	■	-	-	-	■	45	0.32	4.2	-	-	-
	T7325	1.6	■	170	0.45	5.2	■	130	0.41	5.2	■	-	-	-	■	55	0.32	4.2	-	-	-
	T7335	1.6	■	155	0.45	5.2	■	120	0.41	5.2	■	-	-	-	■	50	0.32	4.2	-	-	-
	T9315	1.6	■	205	0.45	5.2	■	-	-	-	■	-	-	-	-	-	-	-	-	-	-
	T9325	1.6	■	185	0.45	5.2	■	110	0.41	5.2	■	-	-	-	■	40	0.32	4.2	-	-	-

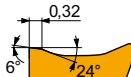

NRM geometri, orta kabadan kabaya kadar işlemek için pozitif tasarım, darbesizden darbeleri kesime kadar uygun.

SNMG 120408-NRM	T7325	0.8	■	175	0.35	2.6	■	135	0.32	2.6	■	-	-	-	■	55	0.28	2.1	-	-	-
	T7335	0.8	■	165	0.35	2.6	■	125	0.32	2.6	■	-	-	-	■	50	0.28	2.1	-	-	-
	T9315	0.8	■	225	0.35	2.6	■	-	-	-	■	-	-	-	-	-	-	-	-	-	-
SNMG 120412-NRM	T7325	1.2	■	175	0.40	3.0	■	135	0.36	3.0	■	-	-	-	■	55	0.28	2.4	-	-	-
	T7335	1.2	■	165	0.40	3.0	■	125	0.36	3.0	■	-	-	-	■	50	0.28	2.4	-	-	-
	T9315	1.2	■	220	0.40	3.0	■	-	-	-	■	-	-	-	-	-	-	-	-	-	-
SNMG 150612-NRM	T7325	1.2	■	170	0.40	4.0	■	130	0.36	4.0	■	-	-	-	■	55	0.32	3.2	-	-	-
	T7335	1.2	■	160	0.40	4.0	■	120	0.36	4.0	■	-	-	-	■	50	0.32	3.2	-	-	-
	T9315	1.2	■	215	0.40	4.0	■	-	-	-	■	-	-	-	-	-	-	-	-	-	-
SNMG 150616-NRM	T7325	1.6	■	170	0.45	5.0	■	130	0.41	5.0	■	-	-	-	■	55	0.36	4.0	-	-	-
	T7335	1.6	■	155	0.45	5.0	■	120	0.41	5.0	■	-	-	-	■	50	0.36	4.0	-	-	-
	T9315	1.6	■	205	0.45	5.0	■	-	-	-	■	-	-	-	-	-	-	-	-	-	-
SNMG 190612-NRM	T7325	1.2	■	165	0.40	5.2	■	125	0.36	5.2	■	-	-	-	■	50	0.32	4.2	-	-	-
	T7335	1.2	■	155	0.40	5.2	■	120	0.36	5.2	■	-	-	-	■	50	0.32	4.2	-	-	-
	T9315	1.2	■	210	0.40	5.2	■	-	-	-	■	-	-	-	-	-	-	-	-	-	-
SNMG 190616-NRM	T7325	1.6	■	170	0.45	5.2	■	130	0.41	5.2	■	-	-	-	■	55	0.36	4.2	-	-	-
	T7335	1.6	■	155	0.45	5.2	■	120	0.41	5.2	■	-	-	-	■	50	0.36	4.2	-	-	-
	T9315	1.6	■	205	0.45	5.2	■	-	-	-	■	-	-	-	-	-	-	-	-	-	-
SNMG 250724-NRM	T7325	2.4	■	105	0.65	9.0	■	80	0.59	9.0	■	-	-	-	■	30	0.46	7.2	-	-	-
	T7335	2.4	■	100	0.65	9.0	■	75	0.59	9.0	■	-	-	-	■	30	0.46	7.2	-	-	-
	T9315	2.4	■	120	0.65	9.0	■	-	-	-	■	110	0.65	9.0	■	-	-	-	-	-	-



Kesme hızı (vc), ilerleme (f) ve kesme derinliği (ap) için uygunluk ve başlangıç değerleri. Daha ileri hesaplamalar için İşleme Hesaplayıcısı uygulamasına başvurun.

Product	RE  (mm)	P			M			K			N			S			H		
		vc (m/min)	f (mm/rev)	ap (mm)	vc (m/min)	f (mm/rev)	ap (mm)	vc (m/min)	f (mm/rev)	ap (mm)	vc (m/min)	f (mm/rev)	ap (mm)	vc (m/min)	f (mm/rev)	ap (mm)	vc (m/min)	f (mm/rev)	ap (mm)

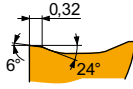

NRM geometri, orta kabadan kabaya kadar işlemek için pozitif tasarım, darbesizden darbeli kesime kadar uygun.

SNMG 250924-NRM	T7325	2.4	105	0.70	9.0	80	0.63	9.0	–	–	–	–	–	–	–	30	0.49	7.2	–	–	–
	T7335	2.4	95	0.70	9.0	70	0.63	9.0	–	–	–	–	–	–	–	30	0.49	7.2	–	–	–
	T9315	2.4	120	0.70	9.0	–	–	–	110	0.70	9.0	–	–	–	–	–	–	–	–	–	–

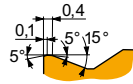

R geometri, orta kabadan kaba işlemeye kadar, darbesizden darbeli kesime kadar uygun.

SNMG 120408E-R	6640	0.8	145	0.40	3.8	–	–	–	135	0.40	3.8	–	–	–	–	–	–	–	–	–	–	–
	T5305	0.8	250	0.40	3.8	–	–	–	235	0.40	3.8	–	–	–	–	–	–	–	50	0.15	1.0	
	T9315	0.8	200	0.40	3.8	–	–	–	190	0.40	3.8	–	–	–	–	–	–	–	40	0.15	1.0	
	T9325	0.8	180	0.40	3.8	–	–	–	170	0.40	3.8	–	–	–	–	–	–	–	–	–	–	–
	T9335	0.8	155	0.40	3.8	–	–	–	–	–	–	–	–	–	–	–	–	–	–	–	–	–
SNMG 120412E-R	T5305	1.2	255	0.45	3.8	–	–	–	240	0.45	3.8	–	–	–	–	–	–	–	50	0.15	1.0	
	T9310	1.2	220	0.45	3.8	–	–	–	205	0.45	3.8	–	–	–	–	–	–	–	40	0.15	1.0	
	T9325	1.2	180	0.45	3.8	–	–	–	170	0.45	3.8	–	–	–	–	–	–	–	–	–	–	
	T9335	1.2	160	0.45	3.8	–	–	–	–	–	–	–	–	–	–	–	–	–	–	–	–	
SNMG 120416E-R	T9315	1.6	205	0.50	3.8	–	–	–	190	0.50	3.8	–	–	–	–	–	–	–	40	0.15	1.0	
	T9325	1.6	185	0.50	3.8	–	–	–	175	0.50	3.8	–	–	–	–	–	–	–	–	–	–	
SNMG 150612E-R	T5305	1.2	250	0.45	4.5	–	–	–	235	0.45	4.5	–	–	–	–	–	–	–	50	0.15	1.0	
	T5315	1.2	230	0.45	4.5	–	–	–	215	0.45	4.5	–	–	–	–	–	–	–	45	0.15	1.0	
	T9315	1.2	200	0.45	4.5	–	–	–	190	0.45	4.5	–	–	–	–	–	–	–	40	0.15	1.0	
	T9325	1.2	180	0.45	4.5	–	–	–	170	0.45	4.5	–	–	–	–	–	–	–	–	–	–	
SNMG 150616E-R	T5315	1.6	230	0.50	4.5	–	–	–	215	0.50	4.5	–	–	–	–	–	–	–	45	0.15	1.0	
	T9325	1.6	180	0.50	4.5	–	–	–	170	0.50	4.5	–	–	–	–	–	–	–	–	–	–	
SNMG 190612E-R	6640	1.2	140	0.45	6.0	–	–	–	130	0.45	6.0	–	–	–	–	–	–	–	–	–	–	
	T9310	1.2	210	0.45	6.0	–	–	–	195	0.45	6.0	–	–	–	–	–	–	–	40	0.15	1.0	
	T9315	1.2	195	0.45	6.0	–	–	–	185	0.45	6.0	–	–	–	–	–	–	–	35	0.15	1.0	
	T9325	1.2	175	0.45	6.0	–	–	–	165	0.45	6.0	–	–	–	–	–	–	–	–	–	–	
SNMG 190616E-R	T9310	1.6	205	0.50	6.0	–	–	–	190	0.50	6.0	–	–	–	–	–	–	–	40	0.15	1.0	
	T9315	1.6	195	0.50	6.0	–	–	–	185	0.50	6.0	–	–	–	–	–	–	–	35	0.15	1.0	
	T9325	1.6	175	0.50	6.0	–	–	–	165	0.50	6.0	–	–	–	–	–	–	–	–	–	–	
	T9335	1.6	150	0.50	6.0	–	–	–	–	–	–	–	–	–	–	–	–	–	–	–	–	

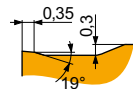

RM geometri, yarı kabadan kaba işlemeye kadar, ve darbesizden darbeli kesime kadar uygun.

SNMG 120408E-RM	T5305	0.8	290	0.40	4.0	–	–	–	275	0.40	4.0	–	–	–	–	–	–	–	–	–	–
	T5315	0.8	260	0.40	4.0	–	–	–	245	0.40	4.0	–	–	–	–	–	–	–	–	–	–
	T6310	0.8	165	0.40	4.0	115	0.36	4.0	130	0.40	4.0	–	–	–	–	–	–	–	–	–	–
	T7325	0.8	185	0.40	4.0	140	0.36	4.0	–	–	–	–	–	–	–	–	–	–	–	–	–
	T7335	0.8	175	0.40	4.0	135	0.36	4.0	–	–	–	–	–	–	–	–	–	–	–	–	–
	T8315	0.8	175	0.40	4.0	105	0.36	4.0	165	0.40	4.0	–	–	–	–	–	–	–	–	–	–
	T8330	0.8	165	0.40	4.0	95	0.36	4.0	155	0.40	4.0	–	–	–	–	–	–	–	–	–	–
	T8430	0.8	175	0.40	4.0	95	0.36	4.0	140	0.40	4.0	–	–	–	–	–	–	–	–	–	–
	T9310	0.8	250	0.40	4.0	–	–	–	235	0.40	4.0	–	–	–	–	–	–	–	–	–	–
	T9315	0.8	235	0.40	4.0	–	–	–	220	0.40	4.0	–	–	–	–	–	–	–	–	–	–
	T9325	0.8	210	0.40	4.0	125	0.36	4.0	195	0.40	4.0	–	–	–	–	–	–	–	–	–	–
	T9335	0.8	180	0.40	4.0	105	0.36	4.0	–	–	–	–	–	–	–	–	–	–	–	–	–



Kesme hızı (vc), ilerleme (f) ve kesme derinliği (ap) için uygunluk ve başlangıç değerleri. Daha ileri hesaplamalar için İşleme Hesaplayıcısı uygulamasına başvurun.

Product	RE (mm)	P			M			K			N			S			H		
		vc (m/min)	f (mm/rev)	ap (mm)	vc (m/min)	f (mm/rev)	ap (mm)	vc (m/min)	f (mm/rev)	ap (mm)	vc (m/min)	f (mm/rev)	ap (mm)	vc (m/min)	f (mm/rev)	ap (mm)	vc (m/min)	f (mm/rev)	ap (mm)

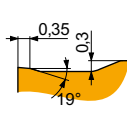

RM geometri, yarı kabadan kaba işleme kadar, ve darbesizden darbeli kesime kadar uygun.

SNMG 120412E-RM	T5305	1.2	295	0.45	4.0	-	-	-	280	0.45	4.0	-	-	-	-	-	-	-	
	T5315	1.2	265	0.45	4.0	-	-	-	250	0.45	4.0	-	-	-	-	-	-	-	
	T6310	1.2	165	0.45	4.0	115	0.41	4.0	130	0.45	4.0	-	-	-	-	-	-	-	
	T7325	1.2	190	0.45	4.0	145	0.41	4.0	-	-	-	-	-	-	-	-	-	-	
	T7335	1.2	180	0.45	4.0	140	0.41	4.0	-	-	-	-	-	-	-	-	-	-	
	T9310	1.2	250	0.45	4.0	-	-	-	235	0.45	4.0	-	-	-	-	-	-	-	-
	T9315	1.2	235	0.45	4.0	-	-	-	220	0.45	4.0	-	-	-	-	-	-	-	-
	T9325	1.2	210	0.45	4.0	125	0.41	4.0	195	0.45	4.0	-	-	-	-	-	-	-	-
	T9335	1.2	185	0.45	4.0	110	0.41	4.0	-	-	-	-	-	-	-	-	-	-	-
SNMG 120416E-RM	T5315	1.6	270	0.50	4.0	-	-	-	255	0.50	4.0	-	-	-	-	-	-	-	
	T7335	1.6	180	0.50	4.0	140	0.45	4.0	-	-	-	-	-	-	-	-	-	-	
	T8330	1.6	170	0.50	4.0	100	0.45	4.0	160	0.50	4.0	-	-	-	-	-	-	-	
	T8430	1.6	175	0.50	4.0	95	0.45	4.0	140	0.50	4.0	-	-	-	-	-	-	-	
	T9315	1.6	230	0.50	4.0	-	-	-	215	0.50	4.0	-	-	-	-	-	-	-	-
	T9325	1.6	215	0.50	4.0	125	0.45	4.0	200	0.50	4.0	-	-	-	-	-	-	-	-
SNMG 150612E-RM	T5315	1.2	255	0.45	5.0	-	-	-	240	0.45	5.0	-	-	-	-	-	-	-	
	T6310	1.2	165	0.45	5.0	115	0.41	5.0	130	0.45	5.0	-	-	-	-	-	-	-	
	T7325	1.2	185	0.45	5.0	140	0.41	5.0	-	-	-	-	-	-	-	-	-	-	
	T7335	1.2	175	0.45	5.0	135	0.41	5.0	-	-	-	-	-	-	-	-	-	-	
	T9310	1.2	245	0.45	5.0	-	-	-	230	0.45	5.0	-	-	-	-	-	-	-	-
	T9315	1.2	225	0.45	5.0	-	-	-	210	0.45	5.0	-	-	-	-	-	-	-	-
	T9325	1.2	205	0.45	5.0	120	0.41	5.0	190	0.45	5.0	-	-	-	-	-	-	-	
SNMG 150616E-RM	T7335	1.6	175	0.50	5.0	135	0.45	5.0	-	-	-	-	-	-	-	-	-	-	
	T9315	1.6	230	0.50	5.0	-	-	-	215	0.50	5.0	-	-	-	-	-	-	-	
	T9325	1.6	205	0.50	5.0	120	0.45	5.0	190	0.50	5.0	-	-	-	-	-	-	-	
	T9335	1.6	180	0.50	5.0	105	0.45	5.0	-	-	-	-	-	-	-	-	-	-	
SNMG 190612E-RM	T5305	1.2	275	0.45	7.0	-	-	-	260	0.45	7.0	-	-	-	-	-	-	-	
	T5315	1.2	250	0.45	7.0	-	-	-	235	0.45	7.0	-	-	-	-	-	-	-	
	T7325	1.2	180	0.45	7.0	140	0.41	7.0	-	-	-	-	-	-	-	-	-	-	
	T7335	1.2	165	0.45	7.0	125	0.41	7.0	-	-	-	-	-	-	-	-	-	-	
	T9310	1.2	240	0.45	7.0	-	-	-	225	0.45	7.0	-	-	-	-	-	-	-	
	T9315	1.2	220	0.45	7.0	-	-	-	205	0.45	7.0	-	-	-	-	-	-	-	-
	T9325	1.2	195	0.45	7.0	115	0.41	7.0	185	0.45	7.0	-	-	-	-	-	-	-	
	T9335	1.2	175	0.45	7.0	105	0.41	7.0	-	-	-	-	-	-	-	-	-	-	
SNMG 190616E-RM	T5305	1.6	285	0.50	7.0	-	-	-	270	0.50	7.0	-	-	-	-	-	-	-	
	T5315	1.6	250	0.50	7.0	-	-	-	235	0.50	7.0	-	-	-	-	-	-	-	
	T6310	1.6	160	0.50	7.0	115	0.45	7.0	125	0.50	7.0	-	-	-	-	-	-	-	
	T7335	1.6	170	0.50	7.0	130	0.45	7.0	-	-	-	-	-	-	-	-	-	-	
	T9310	1.6	240	0.50	7.0	-	-	-	225	0.50	7.0	-	-	-	-	-	-	-	
	T9315	1.6	220	0.50	7.0	-	-	-	205	0.50	7.0	-	-	-	-	-	-	-	
	T9325	1.6	200	0.50	7.0	120	0.45	7.0	190	0.50	7.0	-	-	-	-	-	-	-	
	T9335	1.6	175	0.50	7.0	105	0.45	7.0	-	-	-	-	-	-	-	-	-	-	
SNMG 250924E-RM	T7325	2.4	110	0.80	12.0	85	0.72	12.0	-	-	-	-	-	-	-	-	-	-	
	T7335	2.4	105	0.80	12.0	80	0.72	12.0	-	-	-	-	-	-	-	-	-	-	
	T9226	2.4	95	0.80	12.0	55	0.72	12.0	90	0.80	12.0	-	-	-	-	-	-	-	
	T9315	2.4	125	0.80	12.0	-	-	-	115	0.80	12.0	-	-	-	-	-	-	-	
	T9325	2.4	110	0.80	12.0	65	0.72	12.0	100	0.80	12.0	-	-	-	-	-	-	-	
	T9335	2.4	90	0.80	12.0	50	0.72	12.0	-	-	-	-	-	-	-	-	-	-	

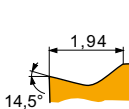

SF geometri, ince finiş ve ince cidar işlemek için pozitif tasarım, darbesiz kesim için uygun.

SNMG 120404E-SF	T7325	0.4	215	0.17	1.0	165	0.15	1.0	-	-	-	-	-	-	65	0.15	0.8	-	-	-
	T9325	0.4	265	0.17	1.0	155	0.15	1.0	250	0.17	1.0	-	-	-	55	0.15	0.8	-	-	-



Kesme hızı (vc), ilerleme (f) ve kesme derinliği (ap) için uygunluk ve başlangıç değerleri. Daha ileri hesaplamalar için İşleme Hesaplayıcısı uygulamasına başvurun.

Product	RE (mm)	P			M			K			N			S			H		
		vc (m/min)	f (mm/rev)	ap (mm)	vc (m/min)	f (mm/rev)	ap (mm)	vc (m/min)	f (mm/rev)	ap (mm)	vc (m/min)	f (mm/rev)	ap (mm)	vc (m/min)	f (mm/rev)	ap (mm)	vc (m/min)	f (mm/rev)	ap (mm)

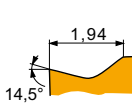

SF geometri, ince finiş ve ince cidar işlemek için pozitif tasarım, darbesiz kesim için uygun.

SNMG 120408E-SF	H07	0.8	—	—	—	105	0.18	1.0	165	0.20	1.0	525	0.24	1.0	50	0.14	0.8	—	—	—
	T6310	0.8	210	0.20	1.0	150	0.18	1.0	165	0.20	1.0	630	0.24	1.0	60	0.14	0.8	40	0.15	1.0
	T7325	0.8	245	0.20	1.0	190	0.18	1.0	—	—	—	—	—	—	75	0.16	0.8	—	—	—
	T7335	0.8	235	0.20	1.0	180	0.18	1.0	—	—	—	—	—	—	75	0.16	0.8	—	—	—
	T8315	0.8	225	0.20	1.0	135	0.18	1.0	210	0.20	1.0	675	0.24	1.0	55	0.14	0.8	45	0.15	1.0
	T8330	0.8	210	0.20	1.0	125	0.18	1.0	195	0.20	1.0	630	0.24	1.0	50	0.14	0.8	40	0.15	1.0
	T8430	0.8	245	0.20	1.0	135	0.18	1.0	200	0.20	1.0	675	0.24	1.0	50	0.14	0.8	40	0.15	1.0
	T9325	0.8	295	0.20	1.0	175	0.18	1.0	280	0.20	1.0	—	—	—	65	0.16	0.8	—	—	—
SNMG 120412E-SF	T6310	1.2	200	0.25	1.5	140	0.23	1.5	160	0.25	1.5	600	0.30	1.5	60	0.18	1.2	40	0.15	1.0
	T7325	1.2	230	0.25	1.5	175	0.23	1.5	—	—	—	—	—	70	0.18	1.2	—	—	—	
	T8330	1.2	200	0.25	1.5	120	0.23	1.5	190	0.25	1.5	600	0.30	1.5	50	0.18	1.2	40	0.15	1.0
	T8430	1.2	225	0.25	1.5	120	0.23	1.5	185	0.25	1.5	615	0.30	1.5	45	0.18	1.2	35	0.15	1.0

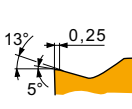

SM geometri, orta işleme için pozitif tasarım, darbesizden darbeli kesime kadar uygun.

SNMG 120408E-SM	T6310	0.8	185	0.25	1.8	130	0.23	1.8	145	0.25	1.8	555	0.30	1.8	55	0.20	1.4	35	0.15	1.0
	T7325	0.8	210	0.25	1.8	160	0.23	1.8	—	—	—	—	—	65	0.20	1.4	—	—	—	
	T7335	0.8	205	0.25	1.8	155	0.23	1.8	—	—	—	—	—	65	0.20	1.4	—	—	—	
	T8330	0.8	185	0.25	1.8	110	0.23	1.8	175	0.25	1.8	555	0.30	1.8	45	0.20	1.4	35	0.15	1.0
	T8430	0.8	205	0.25	1.8	110	0.23	1.8	170	0.25	1.8	570	0.30	1.8	45	0.20	1.4	35	0.15	1.0
	T9315	0.8	280	0.25	1.8	—	—	—	265	0.25	1.8	—	—	—	—	—	—	55	0.15	1.0
T9325	0.8	255	0.25	1.8	150	0.23	1.8	240	0.25	1.8	—	—	—	55	0.20	1.4	—	—	—	
SNMG 120412E-SM	T7325	1.2	210	0.30	1.8	160	0.27	1.8	—	—	—	—	—	65	0.24	1.4	—	—	—	
	T7335	1.2	200	0.30	1.8	155	0.27	1.8	—	—	—	—	—	65	0.24	1.4	—	—	—	
	T9315	1.2	275	0.30	1.8	—	—	—	260	0.30	1.8	—	—	—	—	—	55	0.15	1.0	
	T9325	1.2	245	0.30	1.8	145	0.27	1.8	230	0.30	1.8	—	—	—	55	0.24	1.4	—	—	—
SNMG 190612E-SM	T6310	1.2	175	0.30	4.0	125	0.27	4.0	140	0.30	4.0	525	0.36	4.0	50	0.27	3.2	35	0.15	1.0
	T7325	1.2	195	0.30	4.0	150	0.27	4.0	—	—	—	—	—	60	0.27	3.2	—	—	—	
	T7335	1.2	185	0.30	4.0	140	0.27	4.0	—	—	—	—	—	60	0.27	3.2	—	—	—	
	T9325	1.2	230	0.30	4.0	135	0.27	4.0	215	0.30	4.0	—	—	—	50	0.27	3.2	—	—	—
SNMG 190616E-SM	T7325	1.6	190	0.40	4.0	145	0.36	4.0	—	—	—	—	—	60	0.32	3.2	—	—	—	
	T7335	1.6	175	0.40	4.0	135	0.36	4.0	—	—	—	—	—	55	0.32	3.2	—	—	—	
	T9325	1.6	210	0.40	4.0	125	0.36	4.0	195	0.40	4.0	—	—	—	45	0.32	3.2	—	—	—



SNMM

	IC (mm)	D1 (mm)	L (mm)	S (mm)
1204	12.700	5.16	12.70	4.76
1506	15.875	6.35	15.875	6.35
1906	19.050	7.94	19.05	6.35
2507	25.400	9.12	25.40	7.94
2509	25.400	9.12	25.40	9.525

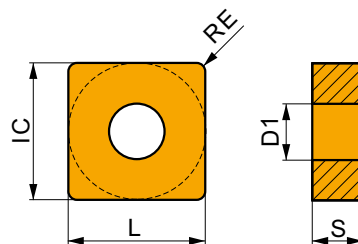

Kesme hızı (vc), ilerleme (f) ve kesme derinliği (ap) için uygunluk ve başlangıç değerleri. Daha ileri hesaplamalar için İşleme Hesaplayıcısı uygulamasına başvurun.

Product	RE (mm)	P			M			K			N			S			H		
		vc (m/min)	f (mm/rev)	ap (mm)	vc (m/min)	f (mm/rev)	ap (mm)	vc (m/min)	f (mm/rev)	ap (mm)	vc (m/min)	f (mm/rev)	ap (mm)	vc (m/min)	f (mm/rev)	ap (mm)	vc (m/min)	f (mm/rev)	ap (mm)

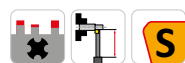
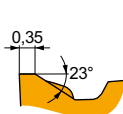

DR geometri, yarı kabadan kaba işlemeye, ve sürekliden aralıklı kesmeye kadar uygun.

SNMM 120412E-DR	T9315	1.2	245	0.45	4.7	–	–	–	230	0.45	4.7	–	–	–	–	–	–	–	–
	T9325	1.2	220	0.45	4.7	130	0.41	4.7	205	0.45	4.7	–	–	–	–	–	–	–	–
	T9335	1.2	185	0.45	4.7	110	0.41	4.7	–	–	–	–	–	–	–	–	–	–	–
SNMM 150612E-DR	T9325	1.2	210	0.45	6.0	125	0.41	6.0	195	0.45	6.0	–	–	–	–	–	–	–	–
	T9335	1.2	180	0.45	6.0	105	0.41	6.0	–	–	–	–	–	–	–	–	–	–	–
SNMM 190612E-DR	6640	1.2	170	0.45	6.0	100	0.41	6.0	160	0.45	6.0	–	–	–	–	–	–	–	–
	T9325	1.2	210	0.45	6.0	125	0.41	6.0	195	0.45	6.0	–	–	–	–	–	–	–	–
	T9335	1.2	180	0.45	6.0	105	0.41	6.0	–	–	–	–	–	–	–	–	–	–	–
SNMM 190616E-DR	T9325	1.6	210	0.50	6.0	125	0.45	6.0	195	0.50	6.0	–	–	–	–	–	–	–	–
	T9335	1.6	185	0.50	6.0	110	0.45	6.0	–	–	–	–	–	–	–	–	–	–	–

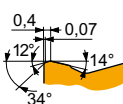

HR geometri, kapadan ağır kaba işlemeye kadar, darbesizden darbeli kesime kadar uygun.

SNMM 190616E-HR	T8345	1.6	60	0.60	9.0	35	0.54	9.0	55	0.60	9.0	–	–	–	–	–	–	–	–
	T9325	1.6	110	0.60	9.0	65	0.54	9.0	100	0.60	9.0	–	–	–	–	–	–	–	–
	T9335	1.6	85	0.60	9.0	50	0.54	9.0	–	–	–	–	–	–	–	–	–	–	–
SNMM 190624E-HR	T8345	2.4	60	0.65	9.0	35	0.59	9.0	55	0.65	9.0	–	–	–	–	–	–	–	–
	T9315	2.4	120	0.65	9.0	–	–	–	110	0.65	9.0	–	–	–	–	–	–	–	–
	T9325	2.4	115	0.65	9.0	65	0.59	9.0	105	0.65	9.0	–	–	–	–	–	–	–	–
SNMM 250716E-HR	T8345	1.6	60	0.60	13.0	35	0.54	13.0	55	0.60	13.0	–	–	–	–	–	–	–	–
	T9325	1.6	100	0.60	13.0	60	0.54	13.0	95	0.60	13.0	–	–	–	–	–	–	–	–
	T9335	1.6	85	0.60	13.0	50	0.54	13.0	–	–	–	–	–	–	–	–	–	–	–
SNMM 250724E-HR	6640	2.4	80	0.65	13.0	45	0.59	13.0	75	0.65	13.0	–	–	–	–	–	–	–	–
	T8345	2.4	55	0.65	13.0	30	0.59	13.0	50	0.65	13.0	–	–	–	–	–	–	–	–
	T9315	2.4	120	0.65	13.0	–	–	–	110	0.65	13.0	–	–	–	–	–	–	–	–
	T9325	2.4	105	0.65	13.0	60	0.59	13.0	95	0.65	13.0	–	–	–	–	–	–	–	–
	T9335	2.4	85	0.65	13.0	50	0.59	13.0	–	–	–	–	–	–	–	–	–	–	–
SNMM 250732E-HR	T9325	3.2	95	0.80	13.0	55	0.72	13.0	90	0.80	13.0	–	–	–	–	–	–	–	–
SNMM 250924E-HR	T8345	2.4	55	0.65	13.0	30	0.59	13.0	50	0.65	13.0	–	–	–	–	–	–	–	–
	T9315	2.4	120	0.65	13.0	–	–	–	110	0.65	13.0	–	–	–	–	–	–	–	–
	T9325	2.4	105	0.65	13.0	60	0.59	13.0	95	0.65	13.0	–	–	–	–	–	–	–	–
	T9335	2.4	85	0.65	13.0	50	0.59	13.0	–	–	–	–	–	–	–	–	–	–	–
SNMM 250932E-HR	T9325	3.2	95	0.80	13.0	55	0.72	13.0	90	0.80	13.0	–	–	–	–	–	–	–	–



Kesme hızı (vc), ilerleme (f) ve kesme derinliği (ap) için uygunluk ve başlangıç değerleri. Daha ileri hesaplamalar için İşleme Hesaplayıcısı uygulamasına başvurun.

Product	RE  (mm)	P			M			K			N			S			H		
		vc (m/min)	f (mm/rev)	ap (mm)	vc (m/min)	f (mm/rev)	ap (mm)	vc (m/min)	f (mm/rev)	ap (mm)	vc (m/min)	f (mm/rev)	ap (mm)	vc (m/min)	f (mm/rev)	ap (mm)	vc (m/min)	f (mm/rev)	ap (mm)

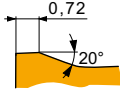

HR2 geometri, kaptan ağır kaba işlemeye kadar, darbesizden darbeli kesime kadar uygun.

SNMM 190616-HR2	T9315	1.6	■	115	0.65	8.9	■	—	—	—	■	105	0.65	8.9	■	—	—	—	—	—	—	—	—	—
	T9335	1.6	■	85	0.65	8.9	■	50	0.59	8.9	■	—	—	—	■	—	—	—	—	—	—	—	—	—
SNMM 190624-HR2	T9315	2.4	■	105	0.85	8.9	■	—	—	—	■	95	0.85	8.9	■	—	—	—	—	—	—	—	—	—
	T9335	2.4	■	80	0.85	8.9	■	45	0.77	8.9	■	—	—	—	■	—	—	—	—	—	—	—	—	—
SNMM 250724-HR2	T9226	2.4	■	85	0.85	11.0	■	50	0.77	11.0	■	80	0.85	11.0	■	—	—	—	—	—	—	—	—	—
	T9315	2.4	■	105	0.85	11.0	■	—	—	—	■	95	0.85	11.0	■	—	—	—	—	—	—	—	—	—
	T9335	2.4	■	80	0.85	11.0	■	45	0.77	11.0	■	—	—	—	■	—	—	—	—	—	—	—	—	—
SNMM 250732-HR2	T9315	3.2	■	95	1.00	11.0	■	—	—	—	■	90	1.00	11.0	■	—	—	—	—	—	—	—	—	—
SNMM 250924-HR2	T9226	2.4	■	85	0.85	11.0	■	50	0.77	11.0	■	80	0.85	11.0	■	—	—	—	—	—	—	—	—	—
	T9315	2.4	■	105	0.85	11.0	■	—	—	—	■	95	0.85	11.0	■	—	—	—	—	—	—	—	—	—
	T9335	2.4	■	80	0.85	11.0	■	45	0.77	11.0	■	—	—	—	■	—	—	—	—	—	—	—	—	—
SNMM 250932-HR2	T9315	3.2	■	95	1.00	11.0	■	—	—	—	■	90	1.00	11.0	■	—	—	—	—	—	—	—	—	—
	T9335	3.2	■	75	1.00	11.0	■	45	0.90	11.0	■	—	—	—	■	—	—	—	—	—	—	—	—	—

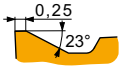

NR geometri, yarı kabadan kaba işlemeye kadar, darbesizden darbeli kesime kadar uygun.

SNMM 120408E-NR	T7325	0.8	■	185	0.40	3.0	■	140	0.36	3.0	■	—	—	—	■	60	0.28	2.4	■	—	—	—	—	—
	T7335	0.8	■	175	0.40	3.0	■	135	0.36	3.0	■	—	—	—	■	55	0.28	2.4	■	—	—	—	—	—
	T8330	0.8	■	160	0.40	3.0	■	95	0.36	3.0	■	150	0.40	3.0	■	40	0.28	2.4	■	—	—	—	—	—
	T8430	0.8	■	170	0.40	3.0	■	90	0.36	3.0	■	135	0.40	3.0	■	35	0.28	2.4	■	—	—	—	—	—
	T9325	0.8	■	205	0.40	3.0	■	120	0.36	3.0	■	190	0.40	3.0	■	45	0.28	2.4	■	—	—	—	—	—

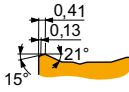

NR2 geometri, yarı kabadan kaba işlemeye kadar, darbesizden darbeli kesime kadar uygun.

SNMM 120408E-NR2	T7325	0.8	■	175	0.40	4.7	■	135	0.36	4.7	■	—	—	—	■	55	0.32	3.8	■	—	—	—	—	—
	T7335	0.8	■	170	0.40	4.7	■	130	0.36	4.7	■	—	—	—	■	55	0.32	3.8	■	—	—	—	—	—
	T8330	0.8	■	155	0.40	4.7	■	90	0.36	4.7	■	145	0.40	4.7	■	35	0.32	3.8	■	—	—	—	—	—
	T8430	0.8	■	165	0.40	4.7	■	90	0.36	4.7	■	135	0.40	4.7	■	35	0.32	3.8	■	—	—	—	—	—
	T9325	0.8	■	195	0.40	4.7	■	115	0.36	4.7	■	185	0.40	4.7	■	40	0.32	3.8	■	—	—	—	—	—
SNMM 120412E-NR2	T7335	1.2	■	165	0.45	4.7	■	125	0.41	4.7	■	—	—	—	■	50	0.36	3.8	■	—	—	—	—	—
	T8330	1.2	■	160	0.45	4.7	■	95	0.41	4.7	■	150	0.45	4.7	■	40	0.36	3.8	■	—	—	—	—	—
	T8430	1.2	■	165	0.45	4.7	■	90	0.41	4.7	■	135	0.45	4.7	■	35	0.36	3.8	■	—	—	—	—	—
	T9325	1.2	■	200	0.45	4.7	■	120	0.41	4.7	■	190	0.45	4.7	■	45	0.36	3.8	■	—	—	—	—	—
SNMM 150612E-NR2	T7325	1.2	■	170	0.45	6.0	■	130	0.41	6.0	■	—	—	—	■	55	0.36	4.8	■	—	—	—	—	—
	T7335	1.2	■	165	0.45	6.0	■	125	0.41	6.0	■	—	—	—	■	50	0.36	4.8	■	—	—	—	—	—
	T8330	1.2	■	155	0.45	6.0	■	90	0.41	6.0	■	145	0.45	6.0	■	35	0.36	4.8	■	—	—	—	—	—
	T8430	1.2	■	165	0.45	6.0	■	90	0.41	6.0	■	135	0.45	6.0	■	35	0.36	4.8	■	—	—	—	—	—
SNMM 150616E-NR2	T7335	1.6	■	165	0.50	6.0	■	125	0.45	6.0	■	—	—	—	■	50	0.40	4.8	■	—	—	—	—	—
	T9325	1.6	■	190	0.50	6.0	■	110	0.45	6.0	■	180	0.50	6.0	■	40	0.40	4.8	■	—	—	—	—	—
SNMM 190612E-NR2	T7335	1.2	■	160	0.45	8.0	■	120	0.41	8.0	■	—	—	—	■	50	0.36	6.4	■	—	—	—	—	—
	T9325	1.2	■	190	0.45	8.0	■	110	0.41	8.0	■	180	0.45	8.0	■	40	0.36	6.4	■	—	—	—	—	—
SNMM 190616E-NR2	T7325	1.6	■	175	0.50	8.0	■	135	0.45	8.0	■	—	—	—	■	55	0.40	6.4	■	—	—	—	—	—
	T7335	1.6	■	160	0.50	8.0	■	120	0.45	8.0	■	—	—	—	■	50	0.40	6.4	■	—	—	—	—	—
	T8330	1.6	■	155	0.50	8.0	■	90	0.45	8.0	■	145	0.50	8.0	■	35	0.40	6.4	■	—	—	—	—	—
	T8430	1.6	■	155	0.50	8.0	■	85	0.45	8.0	■	130	0.50	8.0	■	30	0.40	6.4	■	—	—	—	—	—
	T9315	1.6	■	210	0.50	8.0	■	—	—	—	■	195	0.50	8.0	■	—	—	—	■	—	—	—	—	—
	T9325	1.6	■	185	0.50	8.0	■	110	0.45	8.0	■	175	0.50	8.0	■	40	0.40	6.4	■	—	—	—	—	—
SNMM 190624E-NR2	T7325	2.4	■	155	0.80	8.0	■	120	0.72	8.0	■	—	—	—	■	50	0.56	6.4	■	—	—	—	—	—
	T7335	2.4	■	145	0.80	8.0	■	110	0.72	8.0	■	—	—	—	■	45	0.56	6.4	■	—	—	—	—	—
	T9325	2.4	■	165	0.80	8.0	■	95	0.72	8.0	■	155	0.80	8.0	■	35	0.56	6.4	■	—	—	—	—	—



Kesme hızı (vc), ilerleme (f) ve kesme derinliği (ap) için uygunluk ve başlangıç değerleri. Daha ileri hesaplamalar için İşleme Hesaplayıcısı uygulamasına başvurun.

Product	RE (mm)	P			M			K			N			S			H		
		vc (m/min)	f (mm/rev)	ap (mm)	vc (m/min)	f (mm/rev)	ap (mm)	vc (m/min)	f (mm/rev)	ap (mm)	vc (m/min)	f (mm/rev)	ap (mm)	vc (m/min)	f (mm/rev)	ap (mm)	vc (m/min)	f (mm/rev)	ap (mm)

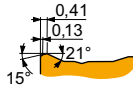

NR2 geometri, yarı kabadan kaba işleme kadar, darbesizden darbeli kesime kadar uygun.

SNMM 250724E-NR2	T7335	2.4	100	0.80	12.0	75	0.72	12.0	-	-	-	-	-	-	30	0.56	9.6	-	-	-
	T8330	2.4	85	0.80	12.0	50	0.72	12.0	80	0.80	12.0	-	-	-	20	0.56	9.6	-	-	-
	T8430	2.4	85	0.80	12.0	45	0.72	12.0	70	0.80	12.0	-	-	-	15	0.56	9.6	-	-	-
	T9226	2.4	95	0.80	12.0	55	0.72	12.0	90	0.80	12.0	-	-	-	20	0.56	9.6	-	-	-
	T9315	2.4	120	0.80	12.0	-	-	-	110	0.80	12.0	-	-	-	-	-	-	-	-	-
SNMM 250924E-NR2	T9325	2.4	105	0.80	12.0	60	0.72	12.0	95	0.80	12.0	-	-	-	20	0.56	9.6	-	-	-
	T7325	2.4	105	0.80	12.0	80	0.72	12.0	-	-	-	-	-	30	0.56	9.6	-	-	-	
	T7335	2.4	100	0.80	12.0	75	0.72	12.0	-	-	-	-	-	30	0.56	9.6	-	-	-	
	T9226	2.4	95	0.80	12.0	55	0.72	12.0	90	0.80	12.0	-	-	-	20	0.56	9.6	-	-	-
	T9315	2.4	120	0.80	12.0	-	-	-	110	0.80	12.0	-	-	-	-	-	-	-	-	-
T9325	2.4	105	0.80	12.0	60	0.72	12.0	95	0.80	12.0	-	-	-	20	0.56	9.6	-	-	-	

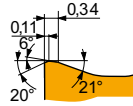

NRM geometri, orta kabadan kabaya kadar işlemek için pozitif tasarım, darbesizden darbeli kesime kadar uygun.

SNMM 250716-NRM	T7325	1.6	115	0.45	9.0	85	0.41	9.0	-	-	-	-	-	35	0.36	7.2	-	-	-
	T7335	1.6	110	0.45	9.0	85	0.41	9.0	-	-	-	-	-	35	0.36	7.2	-	-	-
	T9315	1.6	135	0.45	9.0	-	-	-	125	0.45	9.0	-	-	-	-	-	-	-	-
SNMM 250724-NRM	T7325	2.4	105	0.65	9.0	80	0.59	9.0	-	-	-	-	-	30	0.46	7.2	-	-	-
	T7335	2.4	100	0.65	9.0	75	0.59	9.0	-	-	-	-	-	30	0.46	7.2	-	-	-
	T9315	2.4	120	0.65	9.0	-	-	-	110	0.65	9.0	-	-	-	-	-	-	-	-
SNMM 250924-NRM	T7325	2.4	105	0.70	9.0	80	0.63	9.0	-	-	-	-	-	30	0.49	7.2	-	-	-
	T7335	2.4	95	0.70	9.0	70	0.63	9.0	-	-	-	-	-	30	0.49	7.2	-	-	-
	T9315	2.4	120	0.70	9.0	-	-	-	110	0.70	9.0	-	-	-	-	-	-	-	-

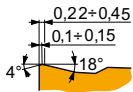

OR geometri, orta kabadan kabaya kadar işlemek için, darbesizden darbeli kesime kadar uygun.

SNMM 120408E-OR	T9315	0.8	220	0.40	4.7	-	-	-	205	0.40	4.7	-	-	-	-	-	-	-	-
	T9325	0.8	195	0.40	4.7	115	0.36	4.7	185	0.40	4.7	-	-	-	40	0.32	3.8	-	-
	T9335	0.8	175	0.40	4.7	105	0.36	4.7	-	-	-	-	-	35	0.32	3.8	-	-	
SNMM 120412E-OR	T9315	1.2	225	0.45	4.7	-	-	-	210	0.45	4.7	-	-	-	-	-	-	-	
	T9325	1.2	200	0.45	4.7	120	0.41	4.7	190	0.45	4.7	-	-	-	45	0.36	3.8	-	-
SNMM 120416E-OR	T9325	1.6	200	0.50	4.7	120	0.45	4.7	190	0.50	4.7	-	-	-	45	0.40	3.8	-	-
SNMM 150608E-OR	T9325	0.8	185	0.45	6.0	110	0.41	6.0	175	0.45	6.0	-	-	-	40	0.41	4.8	-	-
	T9335	0.8	170	0.40	6.0	100	0.36	6.0	-	-	-	-	-	35	0.36	4.8	-	-	
SNMM 150612E-OR	T9325	1.2	195	0.45	6.0	115	0.41	6.0	185	0.45	6.0	-	-	-	40	0.36	4.8	-	-
	T9335	1.2	165	0.45	6.0	95	0.41	6.0	-	-	-	-	-	35	0.36	4.8	-	-	
SNMM 150616E-OR	T9315	1.6	215	0.50	6.0	-	-	-	200	0.50	6.0	-	-	-	-	-	-	-	
	T9325	1.6	190	0.50	6.0	110	0.45	6.0	180	0.50	6.0	-	-	-	40	0.40	4.8	-	-
SNMM 190612E-OR	T8330	1.2	150	0.45	8.0	90	0.41	8.0	140	0.45	8.0	-	-	-	35	0.36	6.4	-	-
	T8430	1.2	150	0.45	8.0	80	0.41	8.0	125	0.45	8.0	-	-	-	30	0.36	6.4	-	-
	T9315	1.2	210	0.45	8.0	-	-	-	195	0.45	8.0	-	-	-	-	-	-	-	
	T9325	1.2	190	0.45	8.0	110	0.41	8.0	180	0.45	8.0	-	-	-	40	0.36	6.4	-	-
	T9335	1.2	165	0.45	8.0	95	0.41	8.0	-	-	-	-	-	35	0.36	6.4	-	-	
SNMM 190616E-OR	T8330	1.6	155	0.50	8.0	90	0.45	8.0	145	0.50	8.0	-	-	-	35	0.40	6.4	-	-
	T8345	1.6	125	0.50	8.0	75	0.45	8.0	115	0.50	8.0	-	-	-	30	0.40	6.4	-	-
	T8430	1.6	155	0.50	8.0	85	0.45	8.0	130	0.50	8.0	-	-	-	30	0.40	6.4	-	-
	T9315	1.6	210	0.50	8.0	-	-	-	195	0.50	8.0	-	-	-	-	-	-	-	
	T9325	1.6	185	0.50	8.0	110	0.45	8.0	175	0.50	8.0	-	-	-	40	0.40	6.4	-	-
SNMM 190624E-OR	T9315	2.4	180	0.80	8.0	-	-	-	170	0.80	8.0	-	-	-	-	-	-	-	
	T9325	2.4	165	0.80	8.0	95	0.72	8.0	155	0.80	8.0	-	-	-	35	0.56	6.4	-	-
SNMM 250716E-OR	T9226	1.6	115	0.50	12.0	65	0.45	12.0	105	0.50	12.0	-	-	-	20	0.45	9.6	-	-
	T9325	1.6	120	0.55	12.0	70	0.50	12.0	110	0.55	12.0	-	-	-	25	0.50	9.6	-	-



Kesme hızı (vc), ilerleme (f) ve kesme derinliği (ap) için uygunluk ve başlangıç değerleri. Daha ileri hesaplamalar için İşleme Hesaplayıcısı uygulamasına başvurun.

Product	RE  (mm)	P			M			K			N			S			H		
		vc (m/min)	f (mm/rev)	ap (mm)	vc (m/min)	f (mm/rev)	ap (mm)	vc (m/min)	f (mm/rev)	ap (mm)	vc (m/min)	f (mm/rev)	ap (mm)	vc (m/min)	f (mm/rev)	ap (mm)	vc (m/min)	f (mm/rev)	ap (mm)

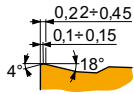

OR geometri, orta kabadan kabaya kadar işlemek için, darbesizden darbeli kesime kadar uygun.

SNMM 250724E-OR	T8330	2.4	80	1.00	12.0	45	0.90	12.0	75	1.00	12.0	—	—	—	20	0.70	9.6	—	—	—	
	T8345	2.4	55	1.00	12.0	30	0.90	12.0	50	1.00	12.0	—	—	—	10	0.70	9.6	—	—	—	
	T8430	2.4	80	1.00	12.0	45	0.90	12.0	65	1.00	12.0	—	—	—	15	0.70	9.6	—	—	—	
	T9315	2.4	105	1.00	12.0	—	—	—	95	1.00	12.0	—	—	—	—	—	—	—	—	—	—
	T9325	2.4	100	1.00	12.0	60	0.90	12.0	95	1.00	12.0	—	—	—	20	0.70	9.6	—	—	—	
SNMM 250924E-OR	T9335	2.4	80	1.00	12.0	45	0.90	12.0	—	—	—	—	—	—	15	0.70	9.6	—	—	—	
	T8430	2.4	80	1.00	12.0	45	0.90	12.0	65	1.00	12.0	—	—	—	15	0.70	9.6	—	—	—	
	T9226	2.4	85	1.00	12.0	50	0.90	12.0	80	1.00	12.0	—	—	—	15	0.70	9.6	—	—	—	
	T9315	2.4	105	1.00	12.0	—	—	—	95	1.00	12.0	—	—	—	—	—	—	—	—	—	
	T9325	2.4	100	1.00	12.0	60	0.90	12.0	95	1.00	12.0	—	—	—	20	0.70	9.6	—	—	—	
T9335	2.4	80	1.00	12.0	45	0.90	12.0	—	—	—	—	—	—	15	0.70	9.6	—	—	—		

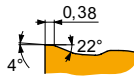

OR geometri, orta kabadan ağır kabaya kadar işlemek için, darbesizden darbeli kesime kadar uygun.

SNMM 190616E-OR1	T9325	1.6	185	0.50	8.0	110	0.45	8.0	175	0.50	8.0	—	—	—	40	0.35	6.4	—	—	—
	T9335	1.6	160	0.50	8.0	95	0.45	8.0	—	—	—	—	—	—	35	0.35	6.4	—	—	—

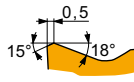

SR geometri, kabadan ağır kaba işlemeye kadar, ve darbesizden darbeli kesime kadar uygun.

SNMM 250724S-SR	6640	2.4	60	1.00	12.0	35	0.90	12.0	55	1.00	12.0	—	—	—	—	—	—	—	—	—
	T9226	2.4	70	1.00	12.0	40	0.90	12.0	65	1.00	12.0	—	—	—	—	—	—	—	—	—
	T9325	2.4	80	1.00	12.0	45	0.90	12.0	75	1.00	12.0	—	—	—	—	—	—	—	—	—
SNMM 250924S-SR	T9335	2.4	65	1.00	14.0	35	0.90	14.0	—	—	—	—	—	—	—	—	—	—	—	—

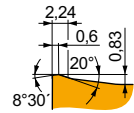

Geometri 923, yarı kabadan ağır kaba işlemeye kadar ve darbesizden ağır darbeli kesime kadar uygun.

SNMM 190616S-923	T8330	1.6	125	0.65	8.9	75	0.59	8.9	115	0.65	8.9	—	—	—	30	0.52	7.1	—	—	—
	T8345	1.6	100	0.65	8.9	60	0.59	8.9	95	0.65	8.9	—	—	—	25	0.52	7.1	—	—	—
	T8430	1.6	125	0.65	8.9	65	0.59	8.9	100	0.65	8.9	—	—	—	25	0.52	7.1	—	—	—
	T9335	1.6	130	0.65	8.9	75	0.59	8.9	—	—	—	—	—	—	25	0.52	7.1	—	—	—
SNMM 250724S-923	T8330	2.4	80	0.85	11.0	45	0.77	11.0	75	0.85	11.0	—	—	—	20	0.60	8.8	—	—	—
	T8430	2.4	80	0.85	11.0	45	0.77	11.0	65	0.85	11.0	—	—	—	15	0.60	8.8	—	—	—
	T9335	2.4	80	0.85	11.0	45	0.77	11.0	—	—	—	—	—	—	15	0.60	8.8	—	—	—
SNMM 250924S-923	T8345	2.4	55	0.85	11.0	30	0.77	11.0	50	0.85	11.0	—	—	—	10	0.60	8.8	—	—	—
	T8430	2.4	80	0.85	11.0	45	0.77	11.0	65	0.85	11.0	—	—	—	15	0.60	8.8	—	—	—
	T9226	2.4	85	0.85	11.0	50	0.77	11.0	80	0.85	11.0	—	—	—	15	0.60	8.8	—	—	—
	T9315	2.4	105	0.85	11.0	—	—	—	95	0.85	11.0	—	—	—	—	—	—	—	—	—
T9335	2.4	80	0.85	11.0	45	0.77	11.0	—	—	—	—	—	—	15	0.60	8.8	—	—	—	
SNMM 250932S-923	T9226	3.2	80	1.00	11.0	45	0.90	11.0	75	1.00	11.0	—	—	—	15	0.70	8.8	—	—	—



SNMX

	IC	D1	L	S
	(mm)	(mm)	(mm)	(mm)
2512	25.400	9.17	25.40	12.00

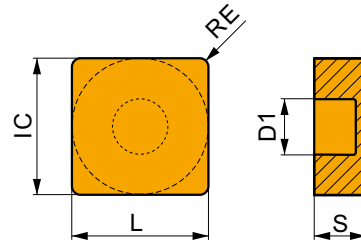

Kesme hızı (vc), ilerleme (f) ve kesme derinliği (ap) için uygunluk ve başlangıç değerleri. Daha ileri hesaplamalar için İşleme Hesaplayıcısı uygulamasına başvurun.

Product	RE	P			M			K			N			S			H		
		vc	f	ap	vc	f	ap	vc	f	ap	vc	f	ap	vc	f	ap	vc	f	ap
	(mm)	(m/min)	(mm/rev)	(mm)	(m/min)	(mm/rev)	(mm)	(m/min)	(mm/rev)	(mm)	(m/min)	(mm/rev)	(mm)	(m/min)	(mm/rev)	(mm)	(m/min)	(mm/rev)	(mm)

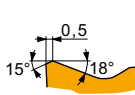

SR geometri, kabadan ağır kaba işlemeye kadar, ve darbesizden darbeli kesime kadar uygun.

SNMX 2512245-SR	T8345	2.4	45	1.00	14.0	25	0.90	14.0	40	1.00	14.0	-	-	-	-	-	-	-	-
	T9325	2.4	80	1.00	14.0	45	0.90	14.0	75	1.00	14.0	-	-	-	-	-	-	-	-
	T9335	2.4	65	1.00	14.0	35	0.90	14.0	-	-	-	-	-	-	-	-	-	-	-

SNGA CER

	IC	D1	L	S
	(mm)	(mm)	(mm)	(mm)
1204	12.700	5.16	12.70	4.76

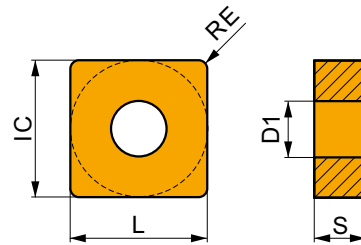

Kesme hızı (vc), ilerleme (f) ve kesme derinliği (ap) için uygunluk ve başlangıç değerleri. Daha ileri hesaplamalar için İşleme Hesaplayıcısı uygulamasına başvurun.

Product	RE	P			M			K			N			S			H		
		vc	f	ap	vc	f	ap	vc	f	ap	vc	f	ap	vc	f	ap	vc	f	ap
	(mm)	(m/min)	(mm/rev)	(mm)	(m/min)	(mm/rev)	(mm)	(m/min)	(mm/rev)	(mm)	(m/min)	(mm/rev)	(mm)	(m/min)	(mm/rev)	(mm)	(m/min)	(mm/rev)	(mm)

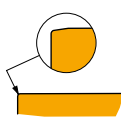

Yüksek hızlı işleme ve darbesiz kesme için.

SNGA 120408 T01025	TC100	0.8	-	-	-	-	-	-	575	0.20	2.0	-	-	-	-	-	-	-	-
SNGA 120412 T01020	TC100	1.2	-	-	-	-	-	-	565	0.25	2.0	-	-	-	-	-	-	-	-



SNGN CER

	IC (mm)	L (mm)	S (mm)
0903	9.525	9.525	3.18
1204	12.700	12.70	4.76
1207	12.700	12.70	7.94

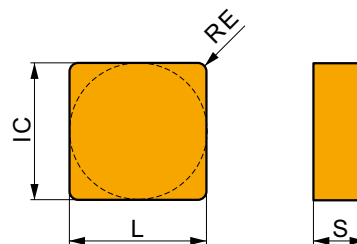

Kesme hızı (vc), ilerleme (f) ve kesme derinliği (ap) için uygunluk ve başlangıç değerleri. Daha ileri hesaplamalar için İşleme Hesaplayıcısı uygulamasına başvurun.

Product	RE (mm)	P			M			K			N			S			H		
		vc (m/min)	f (mm/rev)	ap (mm)	vc (m/min)	f (mm/rev)	ap (mm)	vc (m/min)	f (mm/rev)	ap (mm)	vc (m/min)	f (mm/rev)	ap (mm)	vc (m/min)	f (mm/rev)	ap (mm)	vc (m/min)	f (mm/rev)	ap (mm)

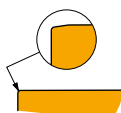

Yüksek hızlı işleme ve darbesiz kesme için.

SNGN 090308 T01020	TC100	0.8	-	-	-	-	-	-	580	0.20	1.8	-	-	-	-	-	-	-	-
SNGN 090312 T01020	TC100	1.2	-	-	-	-	-	-	565	0.25	1.8	-	-	-	-	-	-	-	-
SNGN 120404 T01020	TC100	0.4	-	-	-	-	-	-	620	0.10	2.0	-	-	-	-	-	-	-	-
SNGN 120408 T01020	TC100	0.8	-	-	-	-	-	-	575	0.20	2.0	-	-	-	-	-	-	-	-
SNGN 120708 T01020	TC100	0.8	-	-	-	-	-	-	575	0.20	2.0	-	-	-	-	-	-	-	-
SNGN 120712 T01020	TC100	1.2	-	-	-	-	-	-	565	0.25	2.0	-	-	-	-	-	-	-	-



DSBN(RL) EXT



PRAMET

D



SN.. Uç için Çift Sıkmalı 75° Dış Kateri

Çift sıkmalı 75° Sağ/Sol dış kater. Negatif SN.. 12,15, veya 19 uçlarla çap, kopya, konik ve pah tornalama için uygundur. 20x20 - 40x40mm şaft ölçüleri. Gövde uzun takım ömrü için işlem görmüştür.

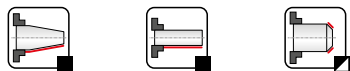
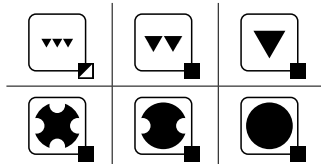
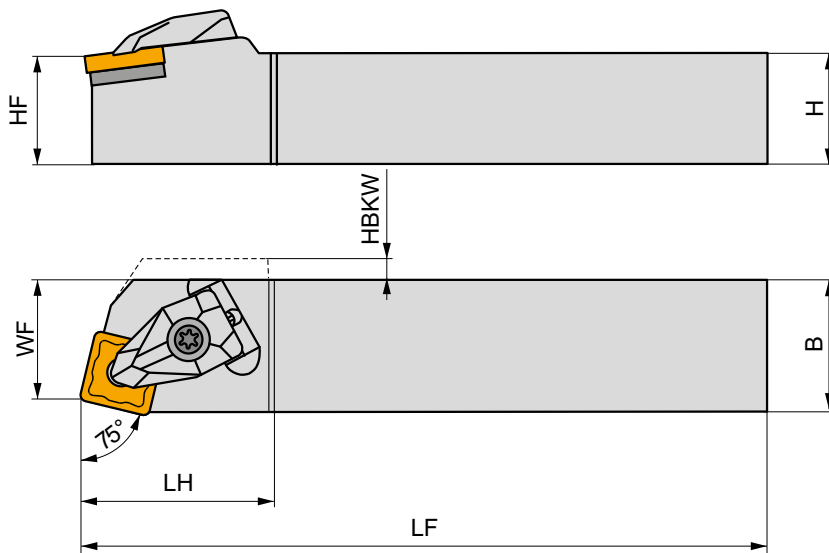
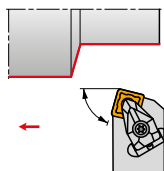

Product	H	B	HF	WF	LF	LH	HBKW	LAMS	GAMO	kg	GI029	DS12	AT003
	(mm)	(mm)	(mm)	(mm)	(mm)	(mm)	(mm)	(°)	(°)				
R DSBNR 2020 K 12	20	20	20	17	125	34.2	2.5	-6	-6	0.43	GI029	DS12	AT003
DSBNR 2525 M 12	25	25	25	22	150	34.3	-	-6	-6	0.74	GI029	DS12	AT003
DSBNR 2525 M 15	25	25	25	22	150	41.6	2	-6	-6	0.80	GI082	DS15	AT006
DSBNR 3225 P 15	32	25	32	22	170	41.7	2	-6	-6	1.07	GI082	DS15	AT006
DSBNR 3232 P 19	32	32	32	27	170	46.4	-	-6	-6	1.38	GI026	DS19	-
DSBNR 4040 S 19	40	40	40	35	250	46.5	-	-6	-6	3.18	GI026	DS19	-
L DSBNL 2525 M 12	25	25	25	22	150	34.3	-	-6	-6	0.74	GI029	DS12	AT003
DSBNL 2525 M 15	25	25	25	22	150	41.6	2	-6	-6	0.80	GI082	DS15	AT006
DSBNL 3225 P 15	32	25	32	22	170	41.7	2	-6	-6	1.16	GI082	DS15	AT006
DSBNL 3232 P 19	32	32	32	27	170	46.4	-	-6	-6	1.38	GI026	DS19	-
DSBNL 4040 S 19	40	40	40	35	250	46.5	-	-6	-6	3.18	GI026	DS19	-



GI026

SN.. 1906..

GI029

SN.. 1204..

GI082

SN.. 1506..



DS12

DCS 12

3.9

DSS 425-01

US 2002-T15P

FLAG T15P/3,5

DS15

DCS 16

6.4

DSS 425-03

US 2007-T20P

-

DS19

DCS 19

6.4

DSS 425-04

US 2007-T20P

-





-

LKT20P

-

LKT20P



			
AT003a	SN.. 1207..	–	DSS 425-02
AT006a	SN.. 1507..	–	DSS 425-05
AT003b	CER SN.N 1204..	DCS 12C4	–
AT003c	CER SN.A 1204..	DCS 12C2	–
AT006b	CER CN.N 1606..	DCS 16C4	–
AT006c	CER CN.A 1606..	DCS 16C2	–



DSDNN EXT

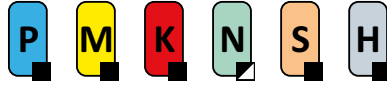

PRAMET

D



SN.. Uç için 45° Açılı Çift Sıkmalı Dış Kater

Çift sıkmalı, 45° açılı nötr dış kater. Negatif SN.. 12, 15, 19 veya 25 uçlarla çap, alın, konik ve pah tornalamak için uygundur. 25x25'ten 40x40'a kadar mevcuttur. Tutucu uzun takım ömrü için işlem görmüştür.

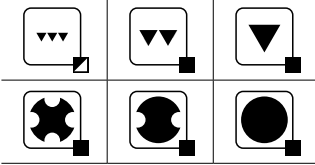
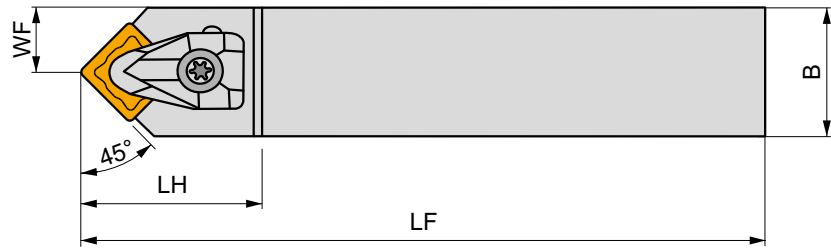
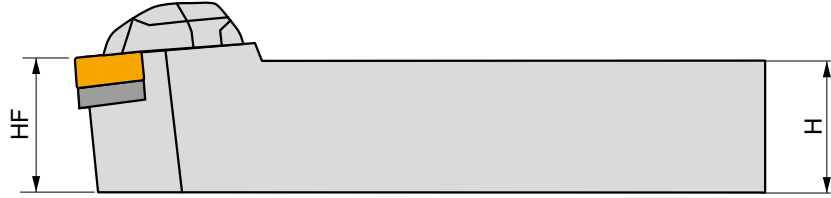
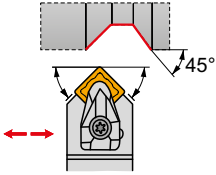

Product	H	B	HF	WF	LF	LH	LAMS	GAMO	kg	GI029	DS12	AT003
	(mm)	(mm)	(mm)	(mm)	(mm)	(mm)	(°)	(°)				
N DSDNN 2525 M 12	25	25	25	12.8	150	36.5	-6	-6	0.74	GI029	DS12	AT003
DSDNN 2525 M 15	25	25	25	12.8	150	44.8	-6	-6	0.76	GI082	DS15	AT006
DSDNN 3232 P 19	32	32	32	16.5	170	49.5	-6	-6	1.36	GI026	DS19	-
DSDNN 4040 S 25	40	40	40	21	250	57.2	-6	-6	3.13	GI027	DS25	-

GI026	SN.. 1906..
GI027	SN.. 2507..
GI029	SN.. 1204..
GI082	SN.. 1506..

DS12	DCS 12	3.9	DSS 425-01	US 2002-T15P	FLAG T15P/3,5	-
DS15	DCS 16	6.4	DSS 425-03	US 2007-T20P	-	LKT20P
DS19	DCS 19	6.4	DSS 425-04	US 2007-T20P	-	LKT20P
DS25	DCS 25	9.5	DSS 425-07	US 2008-T25P	-	LKT25P

AT003a	SN.. 1207..	-	DSS 425-02
AT006a	SN.. 1507..	-	DSS 425-05
AT003b	CER SN.N 1204..	DCS 12C4	-
AT003c	CER SN.A 1204..	DCS 12C2	-
AT006b	CER CN.N 1606..	DCS 16C4	-
AT006c	CER CN.A 1606..	DCS 16C2	-



DSKN(RL) EXT



PRAMET

D



SN.. Uç için Çift Sıkmalı 75° (Alın) Dış Kateri

Çift sıkmalı 75° Sağ/Sol dış kater. Negatif SN.. 12,15, veya 19 uçlarla alın, ve pah tornalama için uygundur. 25x25 - 32x32mm shaft ölçüleri. Gövde uzun takım ömrü için işlem görmüştür.

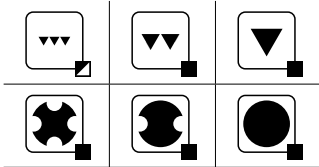
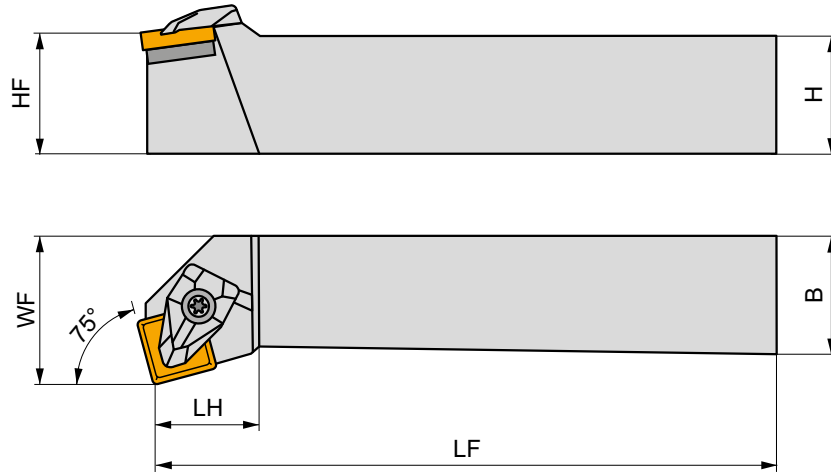
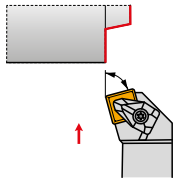

Product	H	B	HF	WF	LF	LH	LAMS	GAMO	kg	GI029	DS12	AT003
	(mm)	(mm)	(mm)	(mm)	(mm)	(mm)	(°)	(°)				
R DSKNR 2525 M 12	25	25	25	32	150	23.6	-6	-6	0.79	GI029	DS12	AT003
DSKNR 3232 P 19	32	32	32	40	170	32.1	-6	-6	1.46	GI026	DS19	-
L DSKNL 2525 M 12	25	25	25	32	150	23.6	-6	-6	0.79	GI029	DS12	AT003
DSKNL 3232 P 19	32	32	32	40	170	32.1	-6	-6	1.46	GI026	DS19	-



GI026

SN.. 1906..

GI029

SN.. 1204..



DS12

DCS 12

3.9

DSS 425-01

US 2002-T15P

FLAG T15P/3,5

-

DS19

DCS 19

6.4

DSS 425-04

US 2007-T20P

-

LK T20P



AT003a

SN.. 1207..

-

DSS 425-02

AT003b

CER SN.N 1204..

DCS 12C4

-

AT003c

CER SN.A 1204..

DCS 12C2

-



DSSN(RL) EXT



PRAMET

D



SN.. Uç için Çift Sıkmalı 45° Dış Kateri

Çift sıkmalı 45° Sağ/Sol dış kater. Negatif SN.. 12,15, veya 19 uçlarla çap, alın, kopya, konik ve pah tornalama için uygundur. 20x20 - 40x40mm shaft ölçüleri. Gövde uzun takım ömrü için işlem görmüştür.

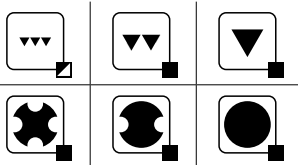
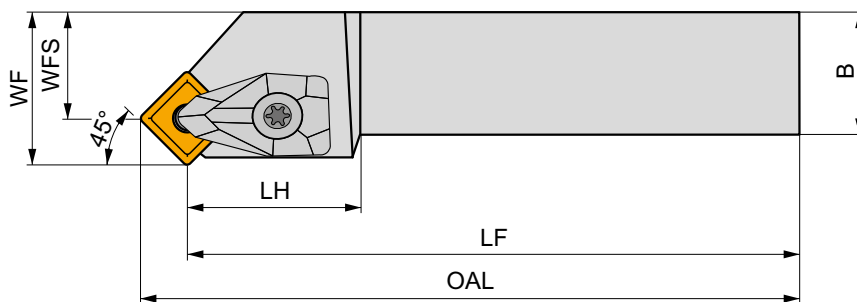
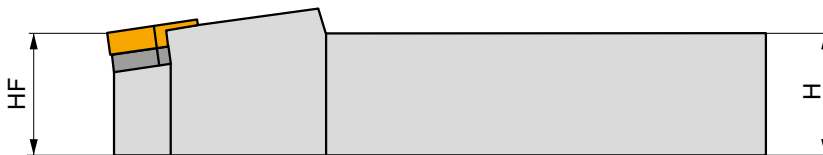
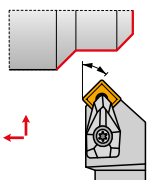

Product	H	B	HF	WF	WFS	LF	OAL	LH	LAMS	GAMO	kg	GI029	DS12	AT003
	(mm)	(mm)	(mm)	(mm)	(mm)	(mm)	(mm)	(mm)	(°)	(°)				
R DSSNR 2020 K 12	20	20	20	25	16.7	125	133.3	27.5	0	-8	0.45	GI029	DS12	AT003
DSSNR 2525 M 12	25	25	25	32	23.7	150	158.3	27.5	0	-8	0.80	GI029	DS12	AT003
DSSNR 2525 M 15	25	25	25	32	21.8	150	160.2	32	0	-8	0.83	GI082	DS15	AT006
DSSNR 3225 P 15	32	25	32	32	21.8	170	180.2	34.9	0	-8	1.16	GI082	DS15	AT006
DSSNR 3232 P 19	32	32	32	40	27.5	170	182.5	37	0	-8	1.48	GI026	DS19	-
DSSNR 4040 S 19	40	40	40	50	37.5	250	262.5	37.7	0	-8	3.27	GI026	DS19	-
L DSSNL 2020 K 12	20	20	20	25	16.7	125	133.3	27.5	0	-8	0.45	GI029	DS12	AT003
DSSNL 2525 M 12	25	25	25	32	23.7	150	158.3	27.5	0	-8	0.19	GI029	DS12	AT003
DSSNL 2525 M 15	25	25	25	32	21.8	150	160.2	32	0	-8	0.83	GI082	DS15	AT006
DSSNL 3225 P 15	32	25	32	32	21.8	170	180.2	34.9	0	-8	1.16	GI082	DS15	AT006
DSSNL 3232 P 19	32	32	32	40	27.5	170	182.5	37	0	-8	1.48	GI026	DS19	-
DSSNL 4040 S 19	40	40	40	50	37.5	250	262.5	37.7	0	-8	3.27	GI026	DS19	-



GI026

SN.. 1906..

GI029

SN.. 1204..

GI082

SN.. 1506..



DS12

DCS 12

3.9

DSS 425-01

US 2002-T15P

FLAG T15P/3,5

-

DS15

DCS 16

6.4

DSS 425-03

US 2007-T20P

-

LKT20P

DS19

DCS 19

6.4

DSS 425-04

US 2007-T20P

-

LKT20P



AT003a

SN.. 1207..

-

DSS 425-02

AT006a

SN.. 1507..

-

DSS 425-05

AT003b

CER SN.N 1204..

DCS 12C4

-

AT003c

CER SN.A 1204..

DCS 12C2

-

AT006b

CER CN.N 1606..

DCS 16C4

-

AT006c

CER CN.A 1606..

DCS 16C2

-



PSBN(RL) EXT

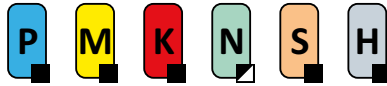

PRAMET

P



SN.. Uç için Levye 75° Açılı Dış Kater

Levyeli, 75° açılı Sağ/Sol dış kater. Negatif SN.. 12, 15, 19 veya 25 uçlarla çap, konik ve pah tornalamak için uygundur. 20x20'den 50x50'ye kadar mevcuttur. Gövde uzun takım ömrü için işlem görmüştür.

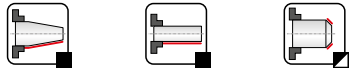
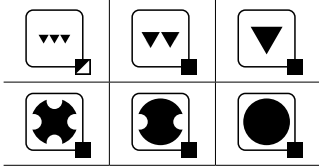
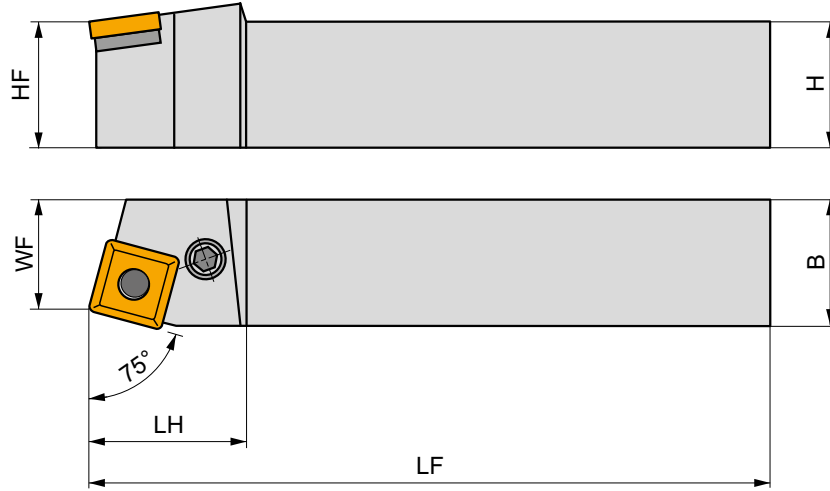
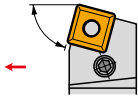

	Product	H	B	HF	WF	LF	LH	LAMS	GAMO	kg	G1029	PS22
		(mm)	(mm)	(mm)	(mm)	(mm)	(mm)	(°)	(°)			
R	PSBNR 2020 K 12	20	20	20	17	125	36	-6	-6	0.43	G1029	PS22
	PSBNR 2525 M 12	25	25	25	22	150	36	-6	-6	0.75	G1029	PS20
	PSBNR 3225 P 15	32	25	32	22	170	40	-6	-6	1.05	G1082	PS40
	PSBNR 3232 P 19	32	32	32	27	170	45	-6	-6	1.30	G1026	PS50
	PSBNR 4040 R 19	40	40	40	35	200	45	-6	-6	2.40	G1026	PS50
	PSBNR 4040 S 19	40	40	40	35	250	45	-6	-6	3.12	G1026	PS50
	PSBNR 4040 R 25	40	40	40	35	200	45	-6	-6	2.45	G1027	PS60
	PSBNR 4040 S 25	40	40	40	35	250	50	-6	-6	2.85	G1027	PS60
	PSBNR 4040 S 2509	40	40	40	35	250	50	-6	-6	2.50	G1040	PS70
	PSBNR 4040 S 2512-A	40	40	40	35	250	50	-6	-6	3.08	G1162	PS72
	PSBNR 5050 S 25	50	50	50	43	250	50	-6	-6	4.70	G1027	PS60
	PSBNR 5050 T 25	50	50	50	43	300	50	-6	-6	5.83	G1027	PS60
	PSBNR 5050 T 2509	50	50	50	43	300	50	-6	-6	5.50	G1040	PS70
	PSBNR 5050 T 2512-A	50	50	50	43	300	50	-6	-6	5.83	G1162	PS72
	L	PSBNL 2020 K 12	20	20	20	17	125	36	-6	-6	0.42	G1029
PSBNL 2525 M 12		25	25	25	22	150	36	-6	-6	0.75	G1029	PS20
PSBNL 3225 P 15		32	25	32	22	170	40	-6	-6	1.05	G1082	PS40
PSBNL 3232 P 19		32	32	32	27	170	45	-6	-6	1.36	G1026	PS50
PSBNL 4040 R 19		40	40	40	35	200	45	-6	-6	2.50	G1026	PS50
PSBNL 4040 S 19		40	40	40	35	250	45	-6	-6	3.13	G1026	PS50
PSBNL 4040 R 25		40	40	40	35	200	45	-6	-6	2.45	G1027	PS60
PSBNL 4040 S 25		40	40	40	35	250	50	-6	-6	3.10	G1027	PS60
PSBNL 4040 S 2509		40	40	40	35	250	50	-6	-6	2.50	G1040	PS70
PSBNL 4040 S 2512-A		40	40	40	35	250	50	-6	-6	3.11	G1162	PS72
PSBNL 5050 S 25		50	50	50	43	250	50	-6	-6	4.70	G1027	PS60
PSBNL 5050 T 25		50	50	50	43	300	50	-6	-6	5.84	G1027	PS60
PSBNL 5050 T 2509		50	50	50	43	300	50	-6	-6	5.80	G1040	PS70



Product	H	B	HF	WF	LF	LH	LAMS	GAMO			
	(mm)	(mm)	(mm)	(mm)	(mm)	(mm)	(°)	(°)			
L PSBNL 5050 T 2512-A	50	50	50	43	300	50	-6	-6	5.82	G162	PS72

GI026	SN.. 1906..
GI027	SN.. 2507..
GI029	SN.. 1204..
GI040	SN.. 2509..
GI082	SN.. 1506..
GI162	SN.. 2512..

PS20	SNU 120312	PU 02	US 35	6.0	M 8x1	22.5	NT 05	MT 05	HXK 4
PS22	SNU 120312	PU 02	US 42	6.0	M 8x1	21	NT 05	MT 05	HXK 4
PS40	SNU 150312	PU 04	US 36	6.0	M 8x1	26	NT 07	MT 07	HXK 4
PS50	SNU 190416	PU 05	US 38	8.0	M 10x1	29	NT 06	MT 06	HXK 5
PS60	SNU 250624	PU 06	US 39	8.0	M 10x1	33	NT 08	MT 08	HXK 5
PS70	SNU 250624	PU 06	US 47	8.0	M 12x1	36	NT 08	MT 08	HXK 5
PS72	SNU 250624	PU 10-N	PS 12040	8.0	M 12x1	40	NT 08	MT 08	HXK 5



PSDNN EXT

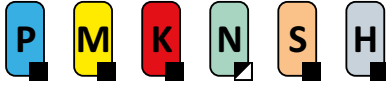

PRAMET

P



SN.. Uç için Levveli 45° Açılı Dış Kater

Levveli, 45° açılı nötr dış kater. Negatif SN.. 12, 15, 19 veya 25 uçlarla çap, alın, konik ve pah tornalamak için uygundur. 20x20'den 50x50'ye kadar mevcuttur. Gövde uzun takım ömrü için işlem görmüştür.

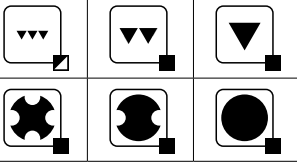
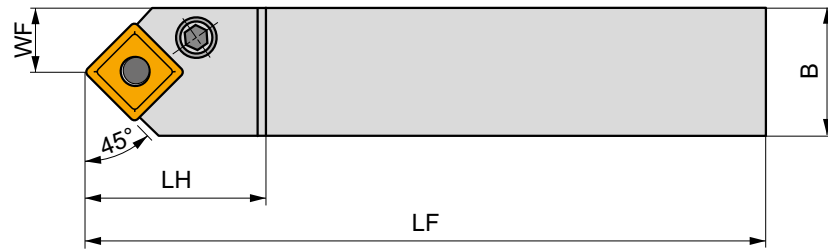
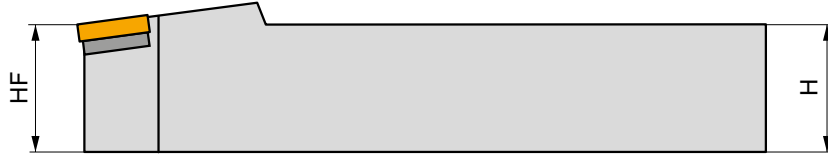
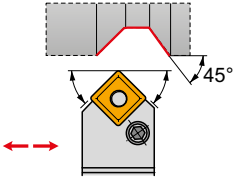

Product	H	B	HF	WF	LF	LH	LAMS	GAMO	kg	GI029	PS22
	(mm)	(mm)	(mm)	(mm)	(mm)	(mm)	(°)	(°)			
PSDNN 2020 K 12	20	20	20	10	125	36	-6	-6	0.42	GI029	PS22
PSDNN 2525 M 12	25	25	25	12.5	150	36	-6	-6	0.68	GI029	PS20
PSDNN 3232 P 15	32	32	32	16	170	40	-6	-6	1.32	GI082	PS40
PSDNN 3232 P 19	32	32	32	16	170	45	-6	-6	1.25	GI026	PS50
PSDNN 4040 S 19	40	40	40	20	250	45	-6	-6	3.05	GI026	PS50
PSDNN 4040 S 25	40	40	40	20	250	50	-6	-6	3.02	GI027	PS60
PSDNN 5050 T 25	50	50	50	25	300	50	-6	-6	5.65	GI027	PS60



GI026
GI027
GI029
GI082

SN.. 1906..
SN.. 2507..
SN.. 1204..
SN.. 1506..



PS20
PS22
PS40
PS50
PS60

SNU 120312
SNU 120312
SNU 150312
SNU 190416
SNU 250624

PU 02
PU 02
PU 04
PU 05
PU 06

US 35
US 42
US 36
US 38
US 39

6.0
6.0
6.0
8.0
8.0

M 8x1
M 8x1
M 8x1
M 10x1
M 10x1

22.5
21
26
29
33

NT 05
NT 05
NT 07
NT 06
NT 08

MT 05
MT 05
MT 07
MT 06
MT 08

HXX 4
HXX 4
HXX 4
HXX 5
HXX 5



PSKN(RL) EXT



PRAMET

P



SN.. Uç için Levveli 75° Açılı (Alın) Dış Kater

Levveli, 75° açılı Sağ/Sol dış kater. Negatif SN.. 12, 15, 19 veya 25 uçlarla alın ve pah tornalamak için uygundur. 20x20'den 50x50'ye kadar mevcuttur. Gövde uzun takım ömrü için işlem görmüştür.

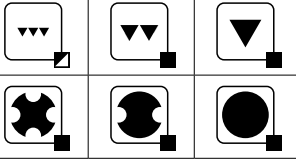
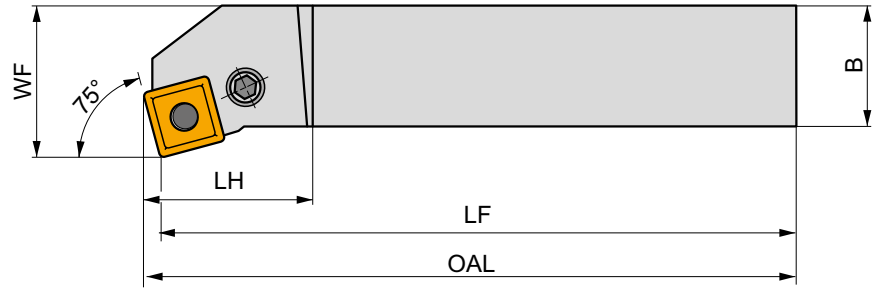
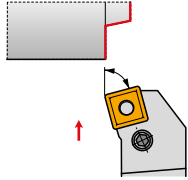

Product	H	B	HF	WF	LF	OAL	LH	LAMS	GAMO	kg	GI029	PS22	
	(mm)	(mm)	(mm)	(mm)	(mm)	(mm)	(mm)	(°)	(°)				
R	PSKNR 2020 K 12	20	20	20	25	125	128.1	36	-6	-6	0.43	GI029	PS22
	PSKNR 2525 M 12	25	25	25	32	150	153.1	36	-6	-6	0.79	GI029	PS20
	PSKNR 3225 P 15	32	25	32	32	170	173.9	40	-6	-6	0.40	GI082	PS40
	PSKNR 3232 P 19	32	32	32	40	170	174.6	45	-6	-6	1.40	GI026	PS50
	PSKNR 4040 S 19	40	40	40	50	250	254.6	45	-6	-6	3.25	GI026	PS50
	PSKNR 4040 S 25	40	40	40	50	250	256.5	50	-6	-6	3.40	GI027	PS60
	PSKNR 5050 T 25	50	50	50	60	300	306.5	50	-6	-6	6.05	GI027	PS60
	PSKNR 5050 T 2509	50	50	50	60	300	306.5	50	-6	-6	6.20	GI040	PS70
L	PSKNL 2020 K 12	20	20	20	25	125	128.1	36	-6	-6	0.43	GI029	PS22
	PSKNL 2525 M 12	25	25	25	32	150	153.1	36	-6	-6	0.79	GI029	PS20
	PSKNL 3225 P 15	32	25	32	32	170	173.9	40	-6	-6	1.05	GI082	PS40
	PSKNL 3232 P 19	32	32	32	40	170	174.6	45	-6	-6	1.40	GI026	PS50
	PSKNL 4040 S 19	40	40	40	50	250	254.6	45	-6	-6	3.26	GI026	PS50
	PSKNL 4040 S 25	40	40	40	50	250	256.5	50	-6	-6	3.40	GI027	PS60
	PSKNL 5050 T 25	50	50	50	60	300	306.5	50	-6	-6	6.00	GI027	PS60
	PSKNL 5050 T 2509	50	50	50	60	300	306.5	50	-6	-6	6.20	GI040	PS70



GI026

SN.. 1906..

GI027

SN.. 2507..

GI029

SN.. 1204..











GI040

SN.. 2509..

GI082

SN.. 1506..



				 Nm					
PS20	SNU 120312	PU 02	US 35	6.0	M 8x1	22.5	NT 05	MT 05	HXX 4
PS22	SNU 120312	PU 02	US 42	6.0	M 8x1	21	NT 05	MT 05	HXX 4
PS40	SNU 150312	PU 04	US 36	6.0	M 8x1	26	NT 07	MT 07	HXX 4
PS50	SNU 190416	PU 05	US 38	8.0	M 10x1	29	NT 06	MT 06	HXX 5
PS60	SNU 250624	PU 06	US 39	8.0	M 10x1	33	NT 08	MT 08	HXX 5
PS70	SNU 250624	PU 06	US 47	8.0	M 12x1	36	NT 08	MT 08	HXX 5



PSSN(RL) EXT



PRAMET

P



SN.. Uç için Levveli 45° Açılı Dış Kater

Levveli, 45° açılı Sağ/Sol dış kater. Negatif SN.. 12, 15, 19 veya 25 uçlarla çap, kopya, konik ve pah tornalamak için uygundur. 20x20'den 50x50'ye kadar mevcuttur. Gövde uzun takım ömrü için işlem görmüştür.

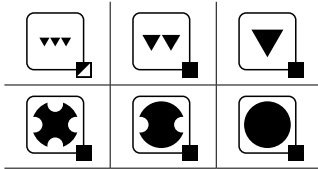
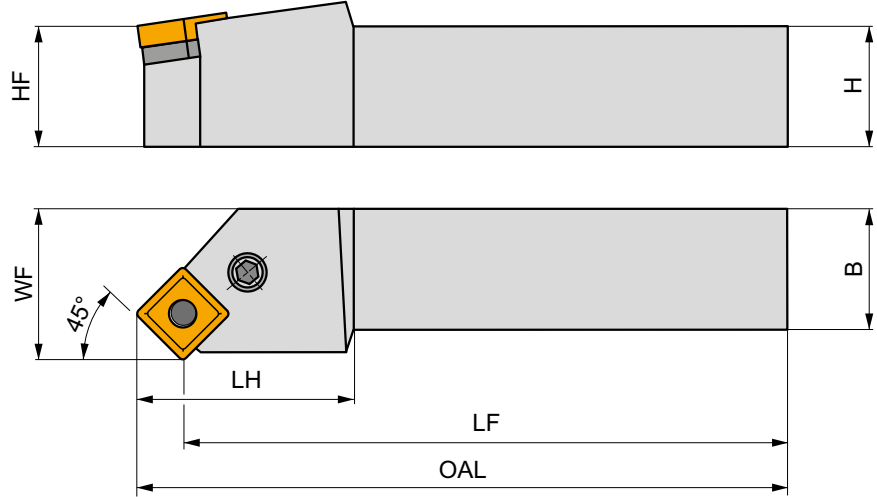
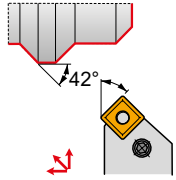

Product	H	B	HF	WF	LF	OAL	LH	LAMS	GAMO	kg			
	(mm)	(mm)	(mm)	(mm)	(mm)	(mm)	(mm)	(°)	(°)				
R	PSSNR 2020 K 12	20	20	20	25	125	133.3	36	0	-8	0.41	GI029	PS22
	PSSNR 2525 M 12	25	25	25	32	150	158.3	36	0	-8	0.75	GI029	PS20
	PSSNR 3225 P 15	32	25	32	32	170	180.2	40	0	-8	1.13	GI082	PS40
	PSSNR 3232 P 19	32	32	32	40	170	182.5	45	0	-8	1.34	GI026	PS50
	PSSNR 4040 R 19	40	40	40	50	200	212.5	45	0	-8	2.50	GI026	PS50
	PSSNR 5050 T 25	50	50	50	60	300	316	50	0	-8	6.00	GI027	PS60
L	PSSNR 5050 T 2509	50	50	50	60	300	316	50	0	-8	6.05	GI040	PS70
	PSSNL 2020 K 12	20	20	20	25	125	133.3	36	0	-8	0.41	GI029	PS22
	PSSNL 2525 M 12	25	25	25	32	150	158.3	36	0	-8	0.67	GI029	PS20
	PSSNL 3225 P 15	32	25	32	32	170	180.2	40	0	-8	1.15	GI082	PS40
	PSSNL 3232 P 19	32	32	32	40	170	182.5	45	0	-8	1.44	GI026	PS50
	PSSNL 4040 R 19	40	40	40	50	200	212.5	45	0	-8	2.58	GI026	PS50
PSSNL 5050 T 25	50	50	50	60	300	316	50	0	-8	6.00	GI027	PS60	
PSSNL 5050 T 2509	50	50	50	60	300	316	50	0	-8	6.08	GI040	PS70	



GI026
GI027
GI029
GI040
GI082

SN.. 1906..
SN.. 2507..
SN.. 1204..
SN.. 2509..
SN.. 1506..



PS20
PS22
PS40
PS50
PS60
PS70

SNU 120312
SNU 120312
SNU 150312
SNU 190416
SNU 250624
SNU 250624

PU 02
PU 02
PU 04
PU 05
PU 06
PU 06

US 35
US 42
US 36
US 38
US 39
US 47

6.0
6.0
6.0
8.0
8.0
8.0

M 8x1
M 8x1
M 8x1
M 10x1
M 10x1
M 12x1

22.5
21
26
29
33
36

NT 05
NT 05
NT 07
NT 06
NT 08
NT 08

MT 05
MT 05
MT 07
MT 06
MT 08
MT 08

HXX 4
HXX 4
HXX 4
HXX 5
HXX 5
HXX 5

NEW
C.-DSDNN EXT

PRAMET
D

SN.. Uç için 45° Açılı PSC Hızlı Değişirli Dış Kater

Çift sıkmalı, 45° açılı, içten su vermeli nötr dış kater. Negatif SN.. 12 veya 19 uçlarla çap, alın, konik ve pah tornalamak için uygundur. C4'ten C6'ya kadar PSC şaftlı mevcuttur. Tutucu uzun takım ömrü için işlem görmüştür.

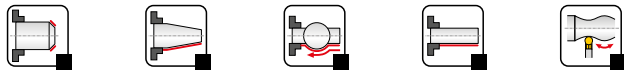
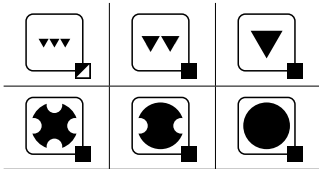
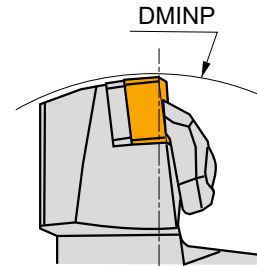
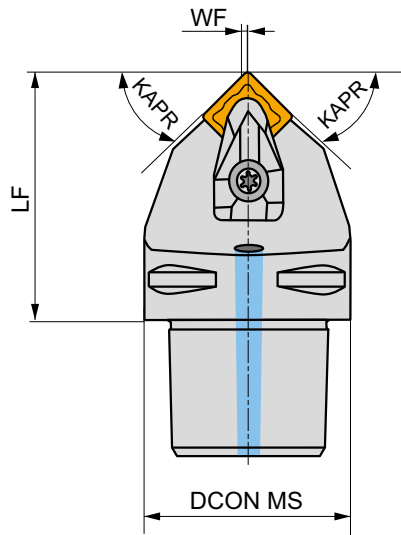
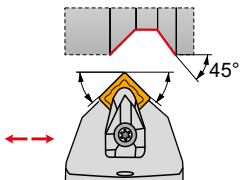

Product	DCON MS (mm)	DMINP (mm)	WF (mm)	LF (mm)	KAPR (°)	LAMS (°)	GAMMO (°)		kg			
N C4-DSDNN-00050-12	40	140	0.3	50	45	-6	-6	✓	0.39	GI029	C-DS12-2	AT003
C5-DSDNN-00060-12	50	165	0.3	60	45	-6	-6	✓	0.69	GI029	C-DS12-2	AT003
C6-DSDNN-00070-19	63	195	0.5	70	45	-6	-6	✓	1.28	GI026	C-DS19	-

GI026	SN.. 1906..
GI029	SN.. 1204..

C-DS12-2	DCS 12	3.9	DSS 425-01	US 2002-T15P	FLAG T15P/3,5	-	CN 045-01
C-DS19	DCS 19	6.4	DSS 425-04	US 2007-T20P	-	LKT20P	CN 045-01

AT003a	SN.. 1207..	-	DSS 425-02
AT003b	CER SN.N 1204..	DCS 12C4	-
AT003c	CER SN.A 1204..	DCS 12C2	-

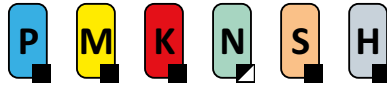
NEW
C.-DSKN(RL) EXT

PRAMET
D

SN.. Uç için Çift Sıkmalı, 75° Açılı (Alın) Hızlı Değişirme Dış Takımı

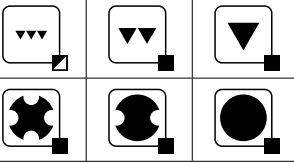
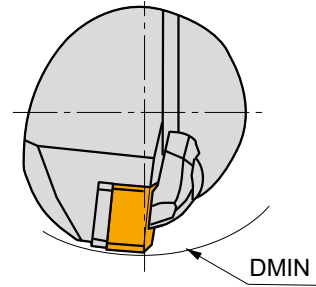
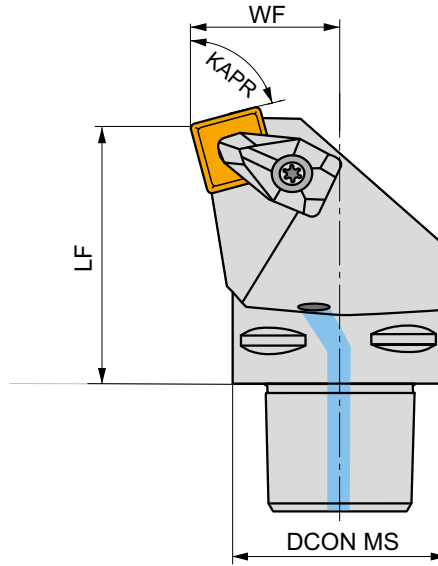
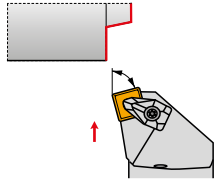
Çift sıkmalı, 75° açılı, içten su vermeli Sağ/Sol dış kater. Negatif SN.. 12 uçlarla alın ve pah tornalamak için uygundur. C4 şaftlı mevcuttur. Tutucu uzun takım ömrü için işlem görmüştür.



Product	DCON MS (mm)	DMIN (mm)	WF (mm)	LF (mm)	KAPR (°)	LAMS (°)	GAMO (°)					
R C4-DSKNR-27050-12	40	110	27	50	75	-6	-6	✓	0.46	G1029	C-DS12-1	AT003
L C4-DSKNL-27050-12	40	110	27	50	75	-6	-6	✓	0.46	G1029	C-DS12-1	AT003



G1029



SN.. 1204..



C-DS12-1



DCS 12



3.9



DSS 425-01



US 2002-T15P



FLAG T15P/3,5



CN 034-01



AT003a



SN.. 1207..



DCS 12C4



DSS 425-02

AT003b

CER SN.N 1204..

DCS 12C2

AT003c

CER SN.A 1204..

NEW
C.-DSRN(RL) EXT

D

SN.. Uç için Çift Sıkmalı, 75° Açılı Hızlı Değişirme Dış Takımı

Çift sıkmalı, 75° açılı, içten su vermeli Sağ/Sol dış kater. Negatif SN.. 12 veya 19 uçlarla çap, alın, konik ve pah tornalamak için uygundur. C4 - C6 şaftlı mevcuttur. Tutucu uzun takım ömrü için işlem görmüştür.

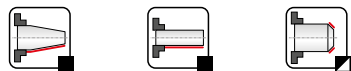
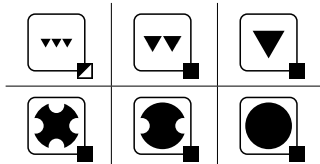
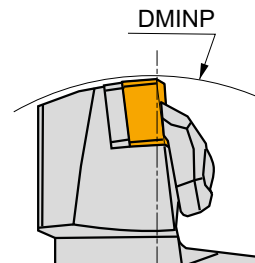
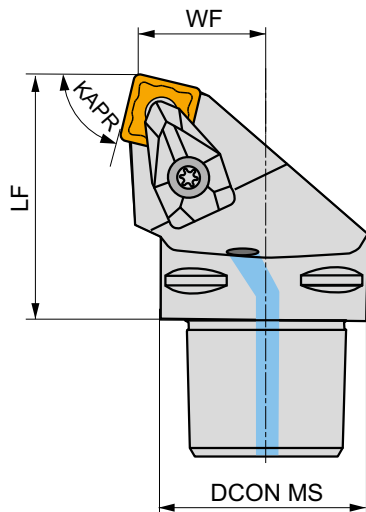
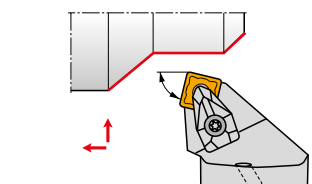

Product	DCON MS (mm)	DMINP (mm)	WF (mm)	LF (mm)	KAPR (°)	LAMS (°)	GAMDO (°)		kg			
R C4-DSRNR-22050-12	40	140	22	50	75	-6	-6	✓	0.40	GI029	C-DS12-1	AT003
C6-DSRNR-35065-19	63	190	35	65	75	-6	-6	✓	1.30	GI026	C-DS19	-
L C4-DSRNL-22050-12	40	140	22	50	75	-6	-6	✓	0.42	GI029	C-DS12-1	AT003
C6-DSRNL-35065-19	63	190	35	65	75	-6	-6	✓	1.30	GI026	C-DS19	-

GI026							SN.. 1906..
GI029							SN.. 1204..

C-DS12-1	DCS 12	3.9	DSS 425-01	US 2002-T15P	FLAG T15P/3,5	-	CN 034-01
C-DS19	DCS 19	6.4	DSS 425-04	US 2007-T20P	-	LK T20P	CN 045-01

AT003a	SN.. 1207..			DSS 425-02
AT003b	CER SN.N 1204..		DCS 12C4	-
AT003c	CER SN.A 1204..		DCS 12C2	-

NEW
C.-DSSN(RL) EXT

PRAMET
D

SN.. Uç için Çift Sıkmalı, 45° Açılı Hızlı Değişirme Dış Takımı

Çift sıkmalı, 45° açılı, içten su vermeli Sağ/Sol dış kater. Negatif SN.. 12 uçlarla çap, alın, konik ve pah tornalamak için uygundur. C4 ve C5 PSC şaftlı mevcuttur. Tutucu uzun takım ömrü için işlem görmüştür.

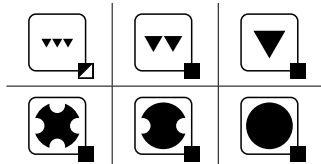
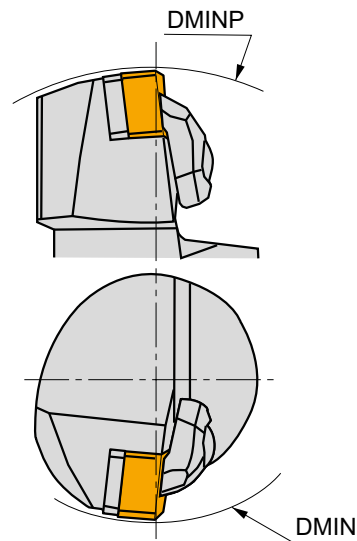
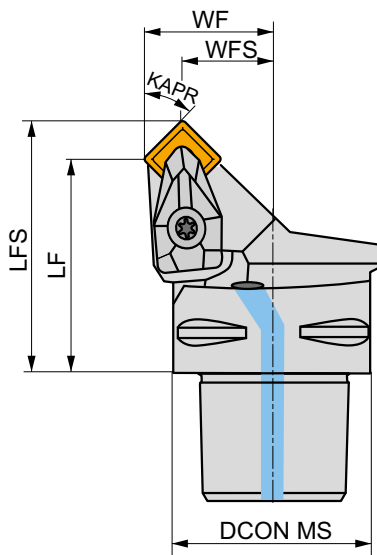
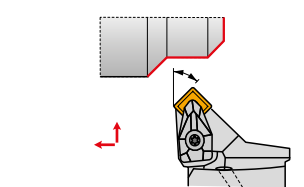

Product	DCON MS	DMIN	DMINP	WF	WFS	LF	LFS	KAPR	LAMS	GAMO						
R	C4-DSSNR-27042-12	40	110	140	27	18.7	42	50.3	45	0	-8	✓	0.38	GI029	C-DS12-1	AT003
	C5-DSSNR-35052-12	50	110	165	35	26.7	52	60.3	45	0	-8	✓	0.68	GI029	C-DS12-3	AT003
L	C4-DSSNL-27042-12	40	110	140	27	18.7	42	50.3	45	0	-8	✓	0.36	GI029	C-DS12-1	AT003
	C5-DSSNL-35052-12	50	110	165	35	26.7	52	60.3	45	0	-8	✓	0.69	GI029	C-DS12-3	AT003



GI029



SN.. 1204..



C-DS12-1

DCS 12

3.9

DSS 425-01

US 2002-T15P

FLAG T15P/3,5

CN 034-01

C-DS12-3

DCS 12

3.9

DSS 425-01

US 2002-T15P

FLAG T15P/3,5

CN 034-02



AT003a

SN.. 1207..

-

DSS 425-02

AT003b

CER SN.N 1204..

DCS 12C4

-

AT003c

CER SN.A 1204..

DCS 12C2

-



KHP-SBN(RL)



PRAMET

P



Modüler KHP Levveli Torna Kartuşu, 75° Kesme Açılı, SN.. Uç için

DKH takım tutucu shaft için kırılmaç bağlantılı, 75° açılı Sağ/Sol levveli kartuş. Negatif SN.. 19 veya 25 uçlarla çap, alın, konik ve pah tornalamak için uygundur. Tutucu uzun takım ömrü için işlem görmüştür.

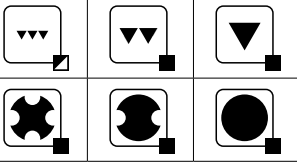
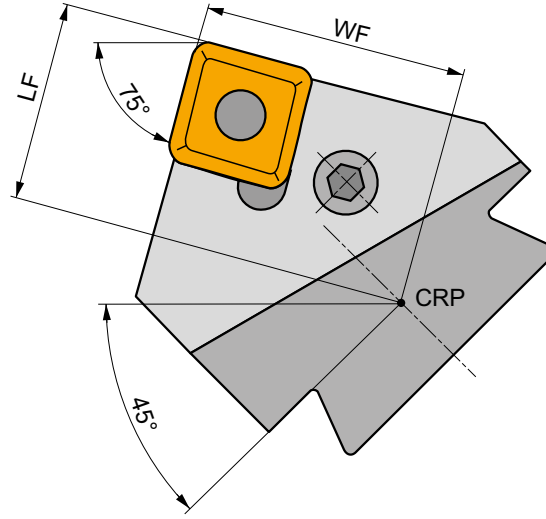
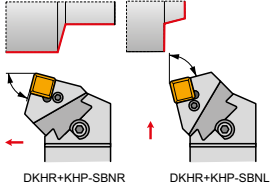

Product	WF (mm)	LF (mm)	LAMS (°)	GAMO (°)	kg	GI026 GI027 GI040 GI162	PS50 PS60 PS70 PS72
R KHP-SBNR 19	47	36	-6	-6	1.51	GI026	PS50
KHP-SBNR 25	47	36	-6	-6	1.47	GI027	PS60
KHP-SBNR 2509	47	36	-6	-6	1.45	GI040	PS70
KHP-SBNR 2512-A	47	36	-6	-6	1.71	GI162	PS72
L KHP-SBNL 19	47	36	-6	-6	1.96	GI026	PS50
KHP-SBNL 25	47	36	-6	-6	1.48	GI027	PS60
KHP-SBNL 2509	47	36	-6	-6	1.46	GI040	PS70
KHP-SBNL 2512-A	47	36	-6	-6	1.45	GI162	PS72



GI026

SN.. 1906..

GI027

SN.. 2507..

GI040

SN.. 2509..

GI162

SN.. 2512..



PS50

SNU 190416

PU 05

US 38

8.0

M 10x1

29

NT 06

MT 06

HXX 5

PS60

SNU 250624

PU 06

US 39

8.0

M 10x1

33

NT 08

MT 08

HXX 5

PS70

SNU 250624

PU 06

US 47

8.0

M 12x1

36

NT 08

MT 08

HXX 5

PS72

SNU 250624

PU 10-N

PS 12040

8.0

M 12x1

40

NT 08

MT 08

HXX 5



KHP-SSN(RL)



PRAMET

P



Modüler KHP Levyeleli Torna Kartuşu, 45° Kesme Açılı, SN.. Uç için

DKH takım tutucu şaft için kırılmalı bağlantılı, 45° açılı Sağ/Sol levyeleli kartuş. Negatif SN.. 19 veya 25 uçlarla çap, alın, konik ve pah tornalamak için uygundur. Tutucu uzun takım ömrü için işlem görmüştür.

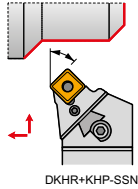

DKHR+KHP-SSNR

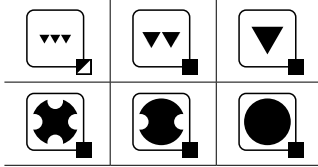
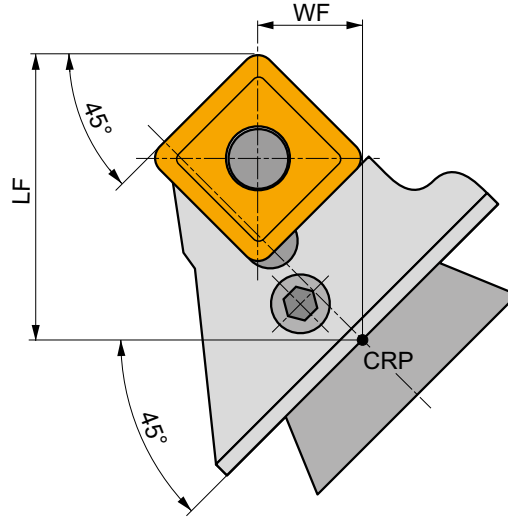

Product	WF	LF	LAMS	GAMO	kg	GI026	PS50	
	(mm)	(mm)	(°)	(°)				
R	KHP-SSNR 19	15	45	-6	-6	1.28	GI026	PS50
	KHP-SSNR 25	15	45	-6	-6	0.98	GI027	PS60
L	KHP-SSNL 19	15	45	-6	-6	1.03	GI026	PS50
	KHP-SSNL 25	15	45	-6	-6	1.30	GI027	PS60

GI026	GI027	SN.. 1906..	SN.. 2507..

PS50	SNU 190416	PU 05	US 38	8.0	M 10x1	29	NT 06	MT 06	HXX 5
PS60	SNU 250624	PU 06	US 39	8.0	M 10x1	33	NT 08	MT 08	HXX 5



DKH(RL)

PRAMET



KHP/KHS Ağır Tornalama Kartuşları için Dış Kater Şaftı

KHP/KHS kartuşlar için kırılmalı Sağ/Sol takım şaftı. Ağır tornalama için uygundur. 40x50'den 60x80mm'ye kadar mevcut. Gövde uzun takım ömrü için işlem görmüştür.

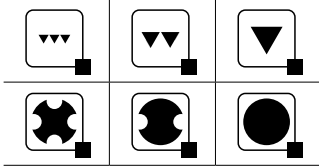
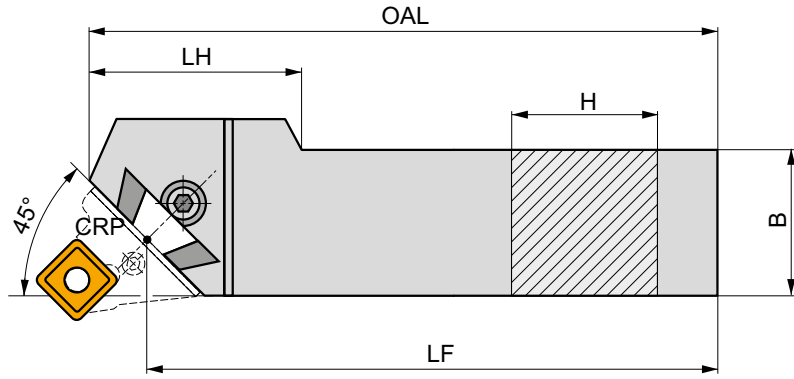
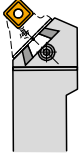

	Product	H	B	LF	OAL	LH	kg	GI098	DKH10
		(mm)	(mm)	(mm)	(mm)	(mm)			
R	DKHR 4050 V	40	50	400	425	100	7.10	GI098	DKH10
	DKHR 5060 W	50	60	450	475	110	11.30	GI098	DKH10
	DKHR 6080 W-A	60	80	450	485	90	19.65	GI098	DKH10
L	DKHL 4050 V	40	50	400	425	100	7.10	GI098	DKH10
	DKHL 5060 W	50	60	450	475	110	11.30	GI098	DKH10
	DKHL 6080 W-A	60	80	450	485	90	19.28	GI098	DKH10



GI098



KHP



KHS



DKH10



SR 14



HXK 10



PSKN(RL) INT

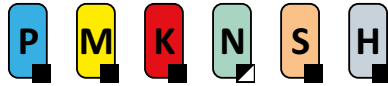

PRAMET

P



SN.. Uç için Levye 75° Açılı Delik Kateri

Levyeli 75° Sağ/Sol içten su vermeli delik kateri. Negatif SN.. 12, 15 veya 19 uçlarla minimum Ø40mm çap, konik ve pah tornalama için uygundur. Ø32-60mm shaft ölçüleri. Gövde uzun takım ömrü için işlem görmüştür.

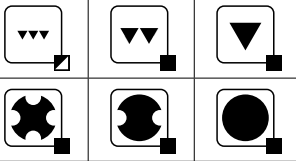
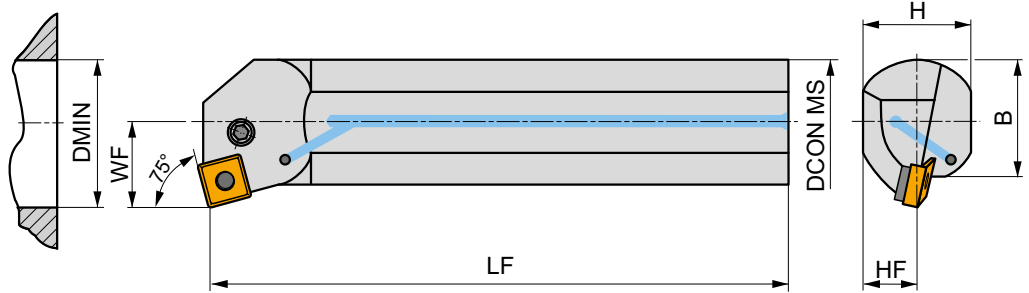
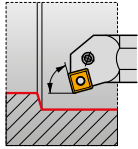

Product	DCON MS (mm)	DMIN (mm)	WF (mm)	H (mm)	B (mm)	LF (mm)	LAMS (°)	GAMO (°)				
R A32S-PSKNR 12	32	40	22	30	30	250	-12	-6	✓	1.50	GI029	PS21
A40T-PSKNR 15	40	50	27	38	38	300	-12	-6	✓	2.90	GI082	PS41
A50U-PSKNR 15	50	63	35	47	48.5	350	-12	-6	✓	5.20	GI082	PS40
A50U-PSKNR 19	50	63	35	47	48.5	350	-12	-6	✓	5.20	GI026	PS50
A60V-PSKNR 19	60	80	43	57	58.5	400	-12	-6	✓	8.70	GI026	PS50
L A32S-PSKNL 12	32	40	22	30	30	250	-12	-6	✓	1.40	GI029	PS21
A40T-PSKNL 15	40	50	27	38	38	300	-12	-6	✓	2.90	GI082	PS41
A50U-PSKNL 15	50	63	35	47	48.5	350	-12	-6	✓	5.20	GI082	PS40
A50U-PSKNL 19	50	63	35	47	48.5	350	-12	-6	✓	5.20	GI026	PS50



GI026

SN.. 1906..

GI029

SN.. 1204..

GI082

SN.. 1506..



PS21

SNU 120312

PU 02

US 41

6.0

M 8x1

17

NT 05

MT 05

HXK 4

PS40

SNU 150312

PU 04

US 36

6.0

M 8x1

26

NT 07

MT 07

HXK 4

PS41

SNU 150312

PU 04

US 40

6.0

M 8x1

20.5

NT 07

MT 07

HXK 4

PS50

SNU 190416

PU 05

US 38

8.0

M 10x1

29

NT 06

MT 06

HXK 5



TN

16/ 22/ 27/ 33

KARBÜR UÇLAR

TNMA	TNMG	TNMM
334	335	342

CER VE CBN UÇLAR

TNGA CER	TNGN CER	TNGA CBN
343	344	344

DOĞRU BOYUTLA EŞLEŞTİRİN (örnek)

Kesici uç	Takım Tutucu
TNMM 160412E-OR	DTFNR 2525 M 16

ISO TORNALAMA - DIŞ

<p>DTFN(RL) EXT</p> <p>90°</p> <p>TN..</p> <p>16 22</p> <p>20×20 25×25</p> <p> 345</p> <p> 334 – 344</p>	<p>DTGN(RL) EXT</p> <p>90°</p> <p>TN..</p> <p>16 22</p> <p>20×20 32×25</p> <p> 346</p> <p> 334 – 344</p>	<p>MTJN(RL) EXT</p> <p>93°</p> <p>TN..</p> <p>16 22</p> <p>16×16 32×32</p> <p> 347</p> <p> 334 – 344</p>	<p>PTFN(RL) EXT</p> <p>90°</p> <p>TN..</p> <p>16 22 27</p> <p>16×16 40×40</p> <p> 348</p> <p> 334 – 344</p>
<p>PTGN(RL) EXT</p> <p>90°</p> <p>TN..</p> <p>16 22 27</p> <p>16×16 40×40</p> <p> 349</p> <p> 334 – 344</p>	<p>PPTN(RL) EXT</p> <p>60°</p> <p>TN..</p> <p>16 22</p> <p>20×20 32×25</p> <p> 350</p> <p> 334 – 344</p>	<p>C.-DTJN(RL) EXT NEW</p> <p>93°</p> <p>TN..</p> <p>16</p> <p>C4 C5</p> <p> 351</p> <p> 334 – 344</p>	



TN

16/ 22/ 27/ 33

ISO TORNALAMA - İÇ

DTFN(RL) INT		PTFN(RL) INT		C.-DTFN(RL) INT NEW	
90°	TN..	90°	TN..	91°	TN..
	16 22		16 22		16
	$\frac{32}{50}$		$\frac{32}{50}$		32
	352		353		354
	334 - 344		334 - 344		334 - 344



TNMA

	IC	D1	L	S
	(mm)	(mm)	(mm)	(mm)
1604	9.525	3.81	16.50	4.76
2204	12.700	5.16	22.00	4.76

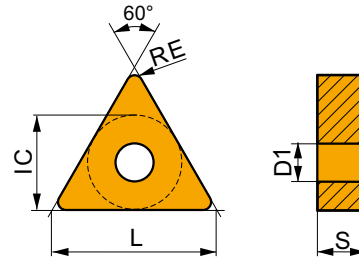

Kesme hızı (vc), ilerleme (f) ve kesme derinliği (ap) için uygunluk ve başlangıç değerleri. Daha ileri hesaplamalar için İşleme Hesaplayıcısı uygulamasına başvurun.

Product	RE	P			M			K			N			S			H		
		vc	f	ap	vc	f	ap	vc	f	ap	vc	f	ap	vc	f	ap	vc	f	ap
	(mm)	(m/min)	(mm/rev)	(mm)	(m/min)	(mm/rev)	(mm)	(m/min)	(mm/rev)	(mm)	(m/min)	(mm/rev)	(mm)	(m/min)	(mm/rev)	(mm)	(m/min)	(mm/rev)	(mm)

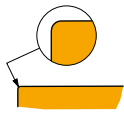

İnce finiştan yarı kaba işleme kadar ve darbesizden hafif darbeli kesmeye kadar uygun.

TNMA 160404	T5305	0.4	-	-	-	-	-	-	220	0.10	1.5	-	-	-	-	-	45	0.15	1.0
	T5315	0.4	-	-	-	-	-	-	190	0.10	1.5	-	-	-	-	-	40	0.15	1.0
TNMA 160408	T5305	0.8	-	-	-	-	-	-	205	0.20	1.5	-	-	-	-	-	40	0.15	1.0
	T5315	0.8	-	-	-	-	-	-	180	0.20	1.5	-	-	-	-	-	35	0.15	1.0
	T6310	0.8	-	-	-	-	-	-	90	0.20	1.5	-	-	-	-	-	20	0.15	1.0
TNMA 160412	T5305	1.2	-	-	-	-	-	-	215	0.20	1.5	-	-	-	-	-	45	0.15	1.0
	T5315	1.2	-	-	-	-	-	-	190	0.20	1.5	-	-	-	-	-	40	0.15	1.0
TNMA 220408	T5305	0.8	-	-	-	-	-	-	195	0.20	2.0	-	-	-	-	-	40	0.15	1.0
	T5315	0.8	-	-	-	-	-	-	175	0.20	2.0	-	-	-	-	-	35	0.15	1.0
	T6310	0.8	-	-	-	-	-	-	90	0.20	2.0	-	-	-	-	-	20	0.15	1.0
TNMA 220412	T5305	1.2	-	-	-	-	-	-	205	0.20	2.0	-	-	-	-	-	40	0.15	1.0
	T5315	1.2	-	-	-	-	-	-	185	0.20	2.0	-	-	-	-	-	35	0.15	1.0

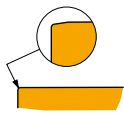

İnce finiştan yarı kaba işleme kadar ve darbesizden hafif darbeli kesmeye kadar uygun.

TNMA 160408S	T5305	0.8	-	-	-	-	-	-	205	0.20	1.5	-	-	-	-	-	40	0.15	1.0
--------------	-------	-----	---	---	---	---	---	---	-----	------	-----	---	---	---	---	---	----	------	-----



TNMG

	IC (mm)	D1 (mm)	L (mm)	S (mm)
1604	9.525	3.81	16.50	4.76
2204	12.700	5.16	22.00	4.76
2706	15.875	6.35	27.50	6.35
3309	19.050	7.94	33.00	9.525

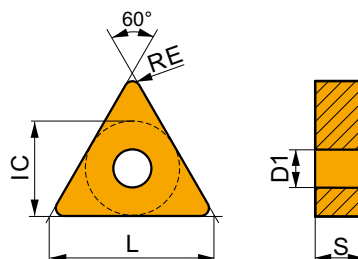

Kesme hızı (vc), ilerleme (f) ve kesme derinliği (ap) için uygunluk ve başlangıç değerleri. Daha ileri hesaplamalar için İşleme Hesaplayıcısı uygulamasına başvurun.

Product	RE (mm)	P			M			K			N			S			H		
		vc (m/min)	f (mm/rev)	ap (mm)	vc (m/min)	f (mm/rev)	ap (mm)	vc (m/min)	f (mm/rev)	ap (mm)	vc (m/min)	f (mm/rev)	ap (mm)	vc (m/min)	f (mm/rev)	ap (mm)	vc (m/min)	f (mm/rev)	ap (mm)

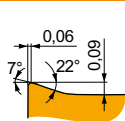

FF geometri, ince-finiş işleme için çok pozitif tasarım, darbesizden hafif darbeli işlemeye kadar uygun.

TNMG 160404E-FF	T7325	0.4	200	0.12	1.0	155	0.11	1.0	-	-	-	-	-	-	-	-	-	-
	T8315	0.4	185	0.12	1.0	110	0.11	1.0	175	0.12	1.0	-	-	-	-	-	-	-
	T8330	0.4	175	0.12	1.0	105	0.11	1.0	165	0.12	1.0	-	-	-	-	-	-	-
	T8430	0.4	210	0.12	1.0	115	0.11	1.0	175	0.12	1.0	-	-	-	-	-	-	-
TNMG 160408E-FF	T7325	0.8	225	0.15	1.0	175	0.14	1.0	-	-	-	-	-	-	-	-	-	-
	T8315	0.8	205	0.15	1.0	120	0.14	1.0	190	0.15	1.0	-	-	-	-	-	-	-

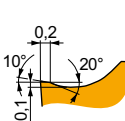

FM pozitif geometri, finişten yarı kaba işlemeye, ve darbesizden hafif darbeli kesmeye kadar uygun.

TNMG 160404E-FM	T7325	0.4	160	0.20	1.7	120	0.18	1.7	-	-	-	50	0.20	1.4	-	-	-	
	T7335	0.4	160	0.20	1.7	120	0.18	1.7	-	-	-	50	0.20	1.4	-	-	-	
	T8315	0.4	150	0.20	1.7	90	0.18	1.7	140	0.20	1.7	35	0.14	1.4	-	-	-	
	T8330	0.4	145	0.20	1.7	85	0.18	1.7	135	0.20	1.7	35	0.14	1.4	-	-	-	
	T8430	0.4	165	0.20	1.7	90	0.18	1.7	135	0.20	1.7	35	0.14	1.4	-	-	-	
	T9310	0.4	245	0.20	1.7	-	-	-	230	0.20	1.7	-	-	-	-	-	-	-
	T9315	0.4	220	0.20	1.7	-	-	-	205	0.20	1.7	-	-	-	-	-	-	-
	T9325	0.4	200	0.20	1.7	120	0.18	1.7	190	0.20	1.7	45	0.20	1.4	-	-	-	
	TT310	0.4	225	0.20	1.7	135	0.18	1.7	-	-	-	-	-	-	-	-	-	
	TNMG 160408E-FM	T7325	0.8	195	0.20	1.7	150	0.18	1.7	-	-	-	60	0.16	1.4	-	-	-
T7335		0.8	190	0.20	1.7	145	0.18	1.7	-	-	-	60	0.16	1.4	-	-	-	
T8315		0.8	180	0.20	1.7	105	0.18	1.7	170	0.20	1.7	45	0.16	1.4	-	-	-	
T8330		0.8	170	0.20	1.7	100	0.18	1.7	160	0.20	1.7	40	0.16	1.4	-	-	-	
T8430		0.8	195	0.20	1.7	105	0.18	1.7	160	0.20	1.7	40	0.16	1.4	-	-	-	
T9310		0.8	290	0.20	1.7	-	-	-	275	0.20	1.7	-	-	-	-	-	-	
T9315		0.8	265	0.20	1.7	-	-	-	250	0.20	1.7	-	-	-	-	-	-	
T9325		0.8	235	0.20	1.7	140	0.18	1.7	220	0.20	1.7	50	0.16	1.4	-	-	-	
TT310		0.8	270	0.20	1.7	160	0.18	1.7	-	-	-	-	-	-	-	-	-	
TNMG 160412E-FM		T7325	1.2	190	0.25	1.7	145	0.23	1.7	-	-	-	60	0.18	1.4	-	-	-
	T8330	1.2	165	0.25	1.7	95	0.23	1.7	155	0.25	1.7	40	0.18	1.4	-	-	-	
	T8430	1.2	185	0.25	1.7	100	0.23	1.7	150	0.25	1.7	40	0.18	1.4	-	-	-	
	T9310	1.2	280	0.25	1.7	-	-	-	265	0.25	1.7	-	-	-	-	-	-	
	T9315	1.2	255	0.25	1.7	-	-	-	240	0.25	1.7	-	-	-	-	-	-	
	T9325	1.2	225	0.25	1.7	135	0.23	1.7	210	0.25	1.7	50	0.18	1.4	-	-	-	
TNMG 220404E-FM	T8330	0.4	145	0.20	1.7	85	0.18	1.7	135	0.20	1.7	35	0.20	1.4	-	-	-	
	T8430	0.4	150	0.24	1.7	80	0.22	1.7	125	0.24	1.7	30	0.22	1.4	-	-	-	
	T9315	0.4	220	0.20	1.7	-	-	-	205	0.20	1.7	-	-	-	-	-	-	
	T9325	0.4	200	0.20	1.7	120	0.18	1.7	190	0.20	1.7	45	0.20	1.4	-	-	-	



Kesme hızı (vc), ilerleme (f) ve kesme derinliği (ap) için uygunluk ve başlangıç değerleri. Daha ileri hesaplamalar için İşleme Hesaplayıcısı uygulamasına başvurun.

Product	RE (mm)	P			M			K			N			S			H		
		vc (m/min)	f (mm/rev)	ap (mm)	vc (m/min)	f (mm/rev)	ap (mm)	vc (m/min)	f (mm/rev)	ap (mm)	vc (m/min)	f (mm/rev)	ap (mm)	vc (m/min)	f (mm/rev)	ap (mm)	vc (m/min)	f (mm/rev)	ap (mm)

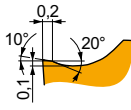

FM pozitif geometri, finiştan yarı kaba işleme, ve darbesizden hafif darbeli kesmeye kadar uygun.

TNMG 220408E-FM	T8330	0.8	170	0.20	1.7	100	0.18	1.7	160	0.20	1.7	—	—	—	40	0.16	1.4	—	—	—
	T8430	0.8	195	0.20	1.7	105	0.18	1.7	160	0.20	1.7	—	—	—	40	0.16	1.4	—	—	—
	T9315	0.8	265	0.20	1.7	—	—	—	250	0.20	1.7	—	—	—	—	—	—	—	—	—
	T9325	0.8	235	0.20	1.7	140	0.18	1.7	220	0.20	1.7	—	—	—	50	0.16	1.4	—	—	—

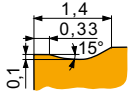

KR geometri, yarı kabadan kaba işleme kadar, darbesizden darbeli kesime kadar uygun.

TNMG 160408E-KR	T5305	0.8	220	0.35	3.0	—	—	—	205	0.35	3.0	—	—	—	40	0.15	1.0	—	—	—
	T5315	0.8	200	0.35	3.0	—	—	—	190	0.35	3.0	—	—	—	40	0.15	1.0	—	—	—

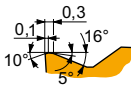

M geometri, finiştan yarı kaba işleme kadar ve darbesizden darbeli kesime kadar uygun.

TNMG 160404E-M	T5315	0.4	215	0.20	1.6	—	—	—	200	0.20	1.6	—	—	—	40	0.15	1.0	—	—	—
	T9315	0.4	205	0.20	1.6	—	—	—	190	0.20	1.6	—	—	—	40	0.15	1.0	—	—	—
	T9325	0.4	180	0.20	1.6	—	—	—	170	0.20	1.6	—	—	—	—	—	—	—	—	—
	T9335	0.4	155	0.20	1.6	—	—	—	—	—	—	—	—	—	—	—	—	—	—	—
TNMG 160408E-M	T5305	0.8	250	0.30	1.6	—	—	—	235	0.30	1.6	—	—	—	50	0.15	1.0	—	—	—
	T5315	0.8	225	0.30	1.6	—	—	—	210	0.30	1.6	—	—	—	45	0.15	1.0	—	—	—
	T9310	0.8	220	0.30	1.6	—	—	—	205	0.30	1.6	—	—	—	40	0.15	1.0	—	—	—
	T9315	0.8	205	0.30	1.6	—	—	—	190	0.30	1.6	—	—	—	40	0.15	1.0	—	—	—
	T9325	0.8	185	0.30	1.6	—	—	—	175	0.30	1.6	—	—	—	—	—	—	—	—	—
TNMG 160412E-M	T5315	1.2	215	0.40	1.6	—	—	—	200	0.40	1.6	—	—	—	40	0.15	1.0	—	—	—
	T9315	1.2	190	0.40	1.6	—	—	—	180	0.40	1.6	—	—	—	35	0.15	1.0	—	—	—
	T9325	1.2	170	0.40	1.6	—	—	—	160	0.40	1.6	—	—	—	—	—	—	—	—	—
	T9335	1.2	145	0.40	1.6	—	—	—	—	—	—	—	—	—	—	—	—	—	—	—
TNMG 220408E-M	T5305	0.8	245	0.30	2.1	—	—	—	230	0.30	2.1	—	—	—	45	0.15	1.0	—	—	—
	T5315	0.8	215	0.30	2.1	—	—	—	200	0.30	2.1	—	—	—	40	0.15	1.0	—	—	—
	T9310	0.8	215	0.30	2.1	—	—	—	200	0.30	2.1	—	—	—	40	0.15	1.0	—	—	—
	T9315	0.8	200	0.30	2.1	—	—	—	190	0.30	2.1	—	—	—	40	0.15	1.0	—	—	—
	T9325	0.8	180	0.30	2.1	—	—	—	170	0.30	2.1	—	—	—	—	—	—	—	—	—
TNMG 220412E-M	T5315	1.2	205	0.40	2.1	—	—	—	190	0.40	2.1	—	—	—	40	0.15	1.0	—	—	—
	T9315	1.2	185	0.40	2.1	—	—	—	175	0.40	2.1	—	—	—	35	0.15	1.0	—	—	—
	T9325	1.2	165	0.40	2.1	—	—	—	155	0.40	2.1	—	—	—	—	—	—	—	—	—
	T9335	1.2	140	0.40	2.1	—	—	—	—	—	—	—	—	—	—	—	—	—	—	—

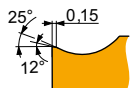

NF geometri, ince finiştan orta kabaya kadar işlemek için çok pozitif tasarım, darbesiz kesim için uygun.

TNMG 160404E-NF	HF7	0.4	—	—	—	90	0.14	1.4	140	0.15	1.4	450	0.18	1.4	—	—	—	—	—	—
	T6310	0.4	150	0.17	1.4	105	0.15	1.4	120	0.17	1.4	450	0.20	1.4	45	0.15	1.1	—	—	—
	T7325	0.4	170	0.18	1.4	130	0.16	1.4	—	—	—	—	—	55	0.16	1.1	—	—	—	
	T7335	0.4	165	0.18	1.4	125	0.16	1.4	—	—	—	—	—	50	0.16	1.1	—	—	—	
	T8315	0.4	160	0.17	1.4	95	0.15	1.4	150	0.17	1.4	480	0.20	1.4	40	0.15	1.1	—	—	—
	T8330	0.4	155	0.17	1.4	90	0.15	1.4	145	0.17	1.4	465	0.20	1.4	35	0.15	1.1	—	—	—
	T8430	0.4	175	0.17	1.4	95	0.15	1.4	140	0.17	1.4	480	0.20	1.4	35	0.15	1.1	—	—	—
	T9315	0.4	255	0.15	1.4	—	—	—	240	0.15	1.4	—	—	—	—	—	—	—	—	—
	T9325	0.4	215	0.18	1.4	125	0.16	1.4	200	0.18	1.4	—	—	—	45	0.16	1.1	—	—	—



Kesme hızı (vc), ilerleme (f) ve kesme derinliği (ap) için uygunluk ve başlangıç değerleri. Daha ileri hesaplamalar için İşleme Hesaplayıcısı uygulamasına başvurun.

Product	RE (mm)	P			M			K			N			S			H		
		vc (m/min)	f (mm/rev)	ap (mm)	vc (m/min)	f (mm/rev)	ap (mm)	vc (m/min)	f (mm/rev)	ap (mm)	vc (m/min)	f (mm/rev)	ap (mm)	vc (m/min)	f (mm/rev)	ap (mm)	vc (m/min)	f (mm/rev)	ap (mm)

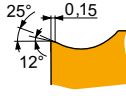

NF geometri, ince finişten orta kabaya kadar işlemek için çok pozitif tasarım, darbesiz kesim için uygun.

TNMG 160408E-NF	HF7	0.8	–	–	–	█	100	0.15	1.4	█	160	0.17	1.4	█	510	0.20	1.4	–	–	–	–	–	–		
	T6310	0.8	█	180	0.18	1.4	█	125	0.16	1.4	█	145	0.18	1.4	█	540	0.22	1.4	█	50	0.16	1.1	–	–	–
	T7325	0.8	█	200	0.18	1.4	█	155	0.16	1.4	–	–	–	–	–	–	–	–	█	65	0.16	1.1	–	–	–
	T7335	0.8	█	195	0.18	1.4	█	150	0.16	1.4	–	–	–	–	–	–	–	–	█	60	0.16	1.1	–	–	–
	T8315	0.8	█	190	0.18	1.4	█	110	0.16	1.4	█	180	0.18	1.4	█	570	0.22	1.4	█	45	0.16	1.1	–	–	–
	T8330	0.8	█	180	0.18	1.4	█	105	0.16	1.4	█	170	0.18	1.4	█	540	0.22	1.4	█	45	0.16	1.1	–	–	–
	T8430	0.8	█	205	0.18	1.4	█	110	0.16	1.4	█	170	0.18	1.4	█	570	0.22	1.4	█	45	0.16	1.1	–	–	–
	T9315	0.8	█	290	0.17	1.4	█	–	–	–	█	275	0.17	1.4	–	–	–	–	–	–	–	–	–	–	–
	T9325	0.8	█	255	0.18	1.4	█	150	0.16	1.4	█	240	0.18	1.4	–	–	–	–	–	█	55	0.16	1.1	–	–

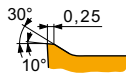

NM geometri, ince finiş, orta ve kaba işlemek için çok pozitif tasarım, darbesiz kesim için uygun.

TNMG 160404E-NM	T7325	0.4	█	170	0.20	1.9	█	130	0.18	1.9	–	–	–	–	–	–	–	–	█	55	0.20	1.5	–	–	–
	T7335	0.4	█	160	0.20	1.9	█	120	0.18	1.9	–	–	–	–	–	–	–	–	█	50	0.20	1.5	–	–	–
	T8315	0.4	█	160	0.20	1.9	█	95	0.18	1.9	–	–	–	█	480	0.24	1.9	█	40	0.20	1.5	–	–	–	
	T8330	0.4	█	145	0.20	1.9	█	85	0.18	1.9	–	–	–	█	435	0.24	1.9	█	35	0.20	1.5	–	–	–	
	T8430	0.4	█	170	0.20	1.9	█	90	0.18	1.9	–	–	–	█	465	0.24	1.9	█	35	0.20	1.5	–	–	–	
	T9325	0.4	█	210	0.20	1.9	█	125	0.18	1.9	–	–	–	–	–	–	–	–	█	45	0.20	1.5	–	–	–
TNMG 160408E-NM	T7325	0.8	█	190	0.25	1.9	█	145	0.23	1.9	–	–	–	–	–	–	–	–	█	60	0.20	1.5	–	–	–
	T7335	0.8	█	180	0.25	1.9	█	140	0.23	1.9	–	–	–	–	–	–	–	–	█	55	0.20	1.5	–	–	–
	T8315	0.8	█	175	0.25	1.9	█	105	0.23	1.9	–	–	–	█	525	0.30	1.9	█	40	0.20	1.5	–	–	–	
	T8330	0.8	█	165	0.25	1.9	█	95	0.23	1.9	–	–	–	█	495	0.30	1.9	█	40	0.20	1.5	–	–	–	
	T8430	0.8	█	185	0.25	1.9	█	100	0.23	1.9	–	–	–	█	510	0.30	1.9	█	40	0.20	1.5	–	–	–	
	T9315	0.8	█	250	0.25	1.9	█	–	–	–	–	–	–	–	–	–	–	–	–	–	–	–	–	–	–
TNMG 220408E-NM	T7325	0.8	█	190	0.25	1.7	█	145	0.23	1.7	–	–	–	–	–	–	–	–	█	60	0.20	1.4	–	–	–
	T7335	0.8	█	185	0.25	1.7	█	140	0.23	1.7	–	–	–	–	–	–	–	–	█	60	0.20	1.4	–	–	–
	T8315	0.8	█	175	0.25	1.7	█	105	0.23	1.7	–	–	–	█	525	0.30	1.7	█	40	0.20	1.4	–	–	–	
	T8330	0.8	█	165	0.25	1.7	█	95	0.23	1.7	–	–	–	█	495	0.30	1.7	█	40	0.20	1.4	–	–	–	
	T8430	0.8	█	185	0.25	1.7	█	100	0.23	1.7	–	–	–	█	510	0.30	1.7	█	40	0.20	1.4	–	–	–	
	T9315	0.8	█	255	0.25	1.7	█	–	–	–	–	–	–	–	–	–	–	–	–	–	–	–	–	–	–
TNMG 220412E-NM	T7325	1.2	█	190	0.30	1.7	█	145	0.27	1.7	–	–	–	–	–	–	–	–	█	50	0.20	1.4	–	–	–
	T7335	1.2	█	180	0.30	2.1	█	140	0.27	2.1	–	–	–	–	–	–	–	–	█	55	0.24	1.7	–	–	–
	T9325	1.2	█	215	0.30	2.1	█	125	0.27	2.1	–	–	–	–	–	–	–	–	█	45	0.24	1.7	–	–	–

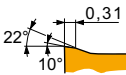

NMR geometri, ortadan kabaya kadar işlemek için pozitif tasarım, darbesiz kesim için uygun.

TNMG 160404E-NMR	T6310	0.4	█	130	0.20	1.7	█	90	0.18	1.7	–	–	–	–	–	–	–	–	█	35	0.18	1.4	–	–	–
	T7325	0.4	█	145	0.20	1.7	█	110	0.18	1.7	–	–	–	–	–	–	–	–	█	45	0.18	1.4	–	–	–
	T7335	0.4	█	145	0.20	1.7	█	110	0.18	1.7	–	–	–	–	–	–	–	–	█	45	0.18	1.4	–	–	–
	T8330	0.4	█	130	0.20	1.7	█	75	0.18	1.7	–	–	–	–	–	–	–	–	█	30	0.18	1.4	–	–	–
	T8430	0.4	█	145	0.20	1.7	█	80	0.18	1.7	–	–	–	–	–	–	–	–	█	30	0.18	1.4	–	–	–
	T9315	0.4	█	200	0.20	1.7	█	–	–	–	–	–	–	–	–	–	–	–	–	–	–	–	–	–	–
TNMG 160408E-NMR	T6310	0.8	█	140	0.30	1.7	█	100	0.27	1.7	–	–	–	–	–	–	–	–	█	40	0.18	1.4	–	–	–
	T7325	0.8	█	155	0.30	1.7	█	120	0.27	1.7	–	–	–	–	–	–	–	–	█	50	0.24	1.4	–	–	–
	T7335	0.8	█	145	0.30	1.7	█	110	0.27	1.7	–	–	–	–	–	–	–	–	█	45	0.24	1.4	–	–	–
	T8330	0.8	█	140	0.30	1.7	█	80	0.27	1.7	–	–	–	–	–	–	–	–	█	35	0.24	1.4	–	–	–
	T8430	0.8	█	150	0.30	1.7	█	80	0.27	1.7	–	–	–	–	–	–	–	–	█	30	0.24	1.4	–	–	–
	T9315	0.8	█	205	0.30	1.7	█	–	–	–	–	–	–	–	–	–	–	–	–	–	–	–	–	–	–
T9325	0.8	█	185	0.30	1.7	█	110	0.27	1.7	–	–	–	–	–	–	–	–	█	40	0.24	1.4	–	–	–	



Kesme hızı (vc), ilerleme (f) ve kesme derinliği (ap) için uygunluk ve başlangıç değerleri. Daha ileri hesaplamalar için İşleme Hesaplayıcısı uygulamasına başvurun.

Product	RE (mm)	P			M			K			N			S			H		
		vc (m/min)	f (mm/rev)	ap (mm)	vc (m/min)	f (mm/rev)	ap (mm)	vc (m/min)	f (mm/rev)	ap (mm)	vc (m/min)	f (mm/rev)	ap (mm)	vc (m/min)	f (mm/rev)	ap (mm)	vc (m/min)	f (mm/rev)	ap (mm)

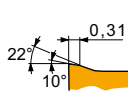

NMR geometri, ortadan kabaya kadar işlemek için pozitif tasarım, darbesiz kesim için uygun.

TNMG 160412E-NMR	T7325	1.2	165	0.30	1.7	125	0.27	1.7	-	-	-	-	-	-	50	0.24	1.4	-	-	-	
	T9315	1.2	215	0.30	1.7	-	-	-	-	-	-	-	-	-	-	-	-	-	-	-	
	T9325	1.2	195	0.30	1.7	115	0.27	1.7	-	-	-	-	-	-	40	0.24	1.4	-	-	-	
TNMG 220408E-NMR	T6310	0.8	135	0.30	2.1	95	0.27	2.1	-	-	-	-	-	-	40	0.24	1.7	-	-	-	
	T7325	0.8	150	0.30	2.1	115	0.27	2.1	-	-	-	-	-	-	45	0.24	1.7	-	-	-	
	T7335	0.8	145	0.30	2.1	110	0.27	2.1	-	-	-	-	-	-	45	0.24	1.7	-	-	-	
	T8330	0.8	135	0.30	2.1	80	0.27	2.1	-	-	-	-	-	-	30	0.24	1.7	-	-	-	
	T8430	0.8	145	0.30	2.1	80	0.27	2.1	-	-	-	-	-	-	30	0.24	1.7	-	-	-	
	T9315	0.8	200	0.30	2.1	-	-	-	-	-	-	-	-	-	-	-	-	-	-	-	-
	T9325	0.8	180	0.30	2.1	105	0.27	2.1	-	-	-	-	-	-	40	0.24	1.7	-	-	-	
TNMG 220412E-NMR	T6310	1.2	140	0.30	2.1	100	0.27	2.1	-	-	-	-	-	-	40	0.24	1.7	-	-	-	
	T7325	1.2	160	0.30	2.1	120	0.27	2.1	-	-	-	-	-	-	50	0.24	1.7	-	-	-	
	T9315	1.2	210	0.30	2.1	-	-	-	-	-	-	-	-	-	-	-	-	-	-	-	
	T9325	1.2	190	0.30	2.1	110	0.27	2.1	-	-	-	-	-	-	40	0.24	1.7	-	-	-	

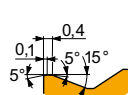

R geometri, orta kabadan kaba işlemeye kadar, darbesizden darbeleri kesime kadar uygun.

TNMG 160408E-R	T5305	0.8	210	0.40	3.0	-	-	-	195	0.40	3.0	-	-	-	-	-	-	40	0.15	1.0
	T5315	0.8	185	0.40	3.0	-	-	-	175	0.40	3.0	-	-	-	-	-	-	35	0.15	1.0
	T9310	0.8	185	0.40	3.0	-	-	-	175	0.40	3.0	-	-	-	-	-	-	35	0.15	1.0
	T9315	0.8	165	0.40	3.0	-	-	-	155	0.40	3.0	-	-	-	-	-	-	30	0.15	1.0
	T9325	0.8	150	0.40	3.0	-	-	-	140	0.40	3.0	-	-	-	-	-	-	-	-	-
	T9335	0.8	130	0.40	3.0	-	-	-	-	-	-	-	-	-	-	-	-	-	-	-
TNMG 160412E-R	T5315	1.2	195	0.40	3.0	-	-	-	185	0.40	3.0	-	-	-	-	-	-	35	0.15	1.0
	T9310	1.2	195	0.40	3.0	-	-	-	185	0.40	3.0	-	-	-	-	-	-	35	0.15	1.0
	T9325	1.2	160	0.40	3.0	-	-	-	150	0.40	3.0	-	-	-	-	-	-	-	-	-
	T9335	1.2	140	0.40	3.0	-	-	-	-	-	-	-	-	-	-	-	-	-	-	-
TNMG 220408E-R	T9315	0.8	165	0.40	4.0	-	-	-	155	0.40	4.0	-	-	-	-	-	-	30	0.15	1.0
	T9325	0.8	145	0.40	4.0	-	-	-	135	0.40	4.0	-	-	-	-	-	-	-	-	-
	T9335	0.8	125	0.40	4.0	-	-	-	-	-	-	-	-	-	-	-	-	-	-	-
TNMG 220412E-R	T9310	1.2	185	0.40	4.0	-	-	-	175	0.40	4.0	-	-	-	-	-	-	35	0.15	1.0
	T9315	1.2	170	0.40	4.0	-	-	-	160	0.40	4.0	-	-	-	-	-	-	30	0.15	1.0
	T9325	1.2	155	0.40	4.0	-	-	-	145	0.40	4.0	-	-	-	-	-	-	-	-	-
TNMG 220416E-R	T9315	1.6	180	0.40	4.0	-	-	-	170	0.40	4.0	-	-	-	-	-	-	35	0.15	1.0
	T9325	1.6	165	0.40	4.0	-	-	-	155	0.40	4.0	-	-	-	-	-	-	-	-	-

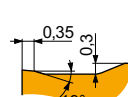

RM geometri, yarı kabadan kaba işlemeye kadar, ve darbesizden darbeleri kesime kadar uygun.

TNMG 160408E-RM	T5305	0.8	245	0.40	3.0	-	-	-	230	0.40	3.0	-	-	-	-	-	-	-	-	-
	T5315	0.8	215	0.40	3.0	-	-	-	200	0.40	3.0	-	-	-	-	-	-	-	-	-
	T7325	0.8	155	0.40	3.0	120	0.36	3.0	-	-	-	-	-	-	-	-	-	-	-	
	T7335	0.8	145	0.40	3.0	110	0.36	3.0	-	-	-	-	-	-	-	-	-	-	-	
	T9310	0.8	210	0.40	3.0	-	-	-	195	0.40	3.0	-	-	-	-	-	-	-	-	-
	T9315	0.8	195	0.40	3.0	-	-	-	185	0.40	3.0	-	-	-	-	-	-	-	-	-
	T9325	0.8	175	0.40	3.0	105	0.36	3.0	165	0.40	3.0	-	-	-	-	-	-	-	-	
	T9335	0.8	150	0.40	3.0	90	0.36	3.0	-	-	-	-	-	-	-	-	-	-	-	



Kesme hızı (vc), ilerleme (f) ve kesme derinliği (ap) için uygunluk ve başlangıç değerleri. Daha ileri hesaplamalar için İşleme Hesaplayıcısı uygulamasına başvurun.

Product	RE (mm)	P			M			K			N			S			H		
		vc (m/min)	f (mm/rev)	ap (mm)	vc (m/min)	f (mm/rev)	ap (mm)	vc (m/min)	f (mm/rev)	ap (mm)	vc (m/min)	f (mm/rev)	ap (mm)	vc (m/min)	f (mm/rev)	ap (mm)	vc (m/min)	f (mm/rev)	ap (mm)

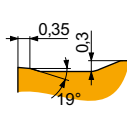

RM geometri, yarı kabadan kaba işlemeye kadar, ve darbesizden darbeli kesime kadar uygun.

TNMG 160412E-RM	T5305	1.2	255	0.40	3.0	-	-	-	240	0.40	3.0	-	-	-	-	-	-	-
	T5315	1.2	225	0.40	3.0	-	-	-	210	0.40	3.0	-	-	-	-	-	-	-
	T7325	1.2	165	0.40	3.0	125	0.36	3.0	-	-	-	-	-	-	-	-	-	-
	T7335	1.2	155	0.40	3.0	120	0.36	3.0	-	-	-	-	-	-	-	-	-	-
	T8330	1.2	145	0.40	3.0	85	0.36	3.0	135	0.40	3.0	-	-	-	-	-	-	-
	T8430	1.2	150	0.40	3.0	80	0.36	3.0	125	0.40	3.0	-	-	-	-	-	-	-
	T9315	1.2	205	0.40	3.0	-	-	-	190	0.40	3.0	-	-	-	-	-	-	-
	T9325	1.2	185	0.40	3.0	110	0.36	3.0	175	0.40	3.0	-	-	-	-	-	-	-
	T9335	1.2	160	0.40	3.0	95	0.36	3.0	-	-	-	-	-	-	-	-	-	-
TNMG 220408E-RM	T5305	0.8	235	0.40	4.0	-	-	-	220	0.40	4.0	-	-	-	-	-	-	-
	T5315	0.8	210	0.40	4.0	-	-	-	195	0.40	4.0	-	-	-	-	-	-	-
	T7325	0.8	150	0.40	4.0	115	0.36	4.0	-	-	-	-	-	-	-	-	-	
	T7335	0.8	140	0.40	4.0	105	0.36	4.0	-	-	-	-	-	-	-	-	-	
	T9310	0.8	200	0.40	4.0	-	-	-	190	0.40	4.0	-	-	-	-	-	-	-
	T9315	0.8	190	0.40	4.0	-	-	-	180	0.40	4.0	-	-	-	-	-	-	-
	T9325	0.8	170	0.40	4.0	100	0.36	4.0	160	0.40	4.0	-	-	-	-	-	-	
	T9335	0.8	145	0.40	4.0	85	0.36	4.0	-	-	-	-	-	-	-	-	-	
	TNMG 220412E-RM	T5305	1.2	245	0.40	4.0	-	-	-	230	0.40	4.0	-	-	-	-	-	-
T5315		1.2	220	0.40	4.0	-	-	-	205	0.40	4.0	-	-	-	-	-	-	-
T7325		1.2	160	0.40	4.0	120	0.36	4.0	-	-	-	-	-	-	-	-	-	
T7335		1.2	150	0.40	4.0	115	0.36	4.0	-	-	-	-	-	-	-	-	-	
T9315		1.2	200	0.40	4.0	-	-	-	190	0.40	4.0	-	-	-	-	-	-	
T9325		1.2	180	0.40	4.0	105	0.36	4.0	170	0.40	4.0	-	-	-	-	-	-	
T9335		1.2	155	0.40	4.0	90	0.36	4.0	-	-	-	-	-	-	-	-	-	
TNMG 220416E-RM		T7325	1.6	165	0.40	4.0	125	0.36	4.0	-	-	-	-	-	-	-	-	-
		T9315	1.6	210	0.40	4.0	-	-	-	195	0.40	4.0	-	-	-	-	-	-
	T9325	1.6	185	0.40	4.0	110	0.36	4.0	175	0.40	4.0	-	-	-	-	-		
	T9335	1.6	160	0.40	4.0	95	0.36	4.0	-	-	-	-	-	-	-	-		
TNMG 270612E-RM	T7325	1.2	110	0.40	6.0	85	0.36	6.0	-	-	-	-	-	-	-	-	-	
	T9325	1.2	120	0.40	6.0	70	0.36	6.0	110	0.40	6.0	-	-	-	-	-		
TNMG 270616E-RM	T7325	1.6	115	0.40	6.0	85	0.36	6.0	-	-	-	-	-	-	-	-	-	
	T9226	1.6	115	0.40	6.0	65	0.36	6.0	105	0.40	6.0	-	-	-	-	-		
	T9315	1.6	135	0.40	6.0	-	-	-	125	0.40	6.0	-	-	-	-	-		
	T9325	1.6	125	0.40	6.0	75	0.36	6.0	115	0.40	6.0	-	-	-	-	-		
TNMG 270624E-RM	T7325	2.4	115	0.50	6.0	85	0.45	6.0	-	-	-	-	-	-	-	-	-	
	T9325	2.4	120	0.50	6.0	70	0.45	6.0	110	0.50	6.0	-	-	-	-	-		
	T9335	2.4	95	0.50	6.0	55	0.45	6.0	-	-	-	-	-	-	-			
TNMG 270632E-RM	T9335	3.2	90	0.60	6.0	50	0.54	6.0	-	-	-	-	-	-	-	-		
TNMG 330924E-RM	T9226	2.4	100	0.50	10.0	60	0.45	10.0	95	0.50	10.0	-	-	-	-	-		
	T9335	2.4	90	0.50	10.0	50	0.45	10.0	-	-	-	-	-	-	-			

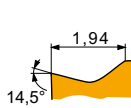

SF geometri, ince finiş ve ince cidar işlemek için pozitif tasarım, darbesiz kesim için uygun.

TNMG 160404E-SF	H07	0.4	-	-	-	75	0.14	1.3	120	0.15	1.3	390	0.18	1.3	35	0.12	1.0	-	-	-
	T6310	0.4	150	0.15	1.3	105	0.14	1.3	120	0.15	1.3	450	0.18	1.3	45	0.12	1.0	30	0.15	1.0
	T7325	0.4	170	0.17	1.3	130	0.15	1.3	-	-	-	-	-	-	55	0.15	1.0	-	-	-
	T7335	0.4	165	0.17	1.3	125	0.15	1.3	-	-	-	-	-	-	50	0.15	1.0	-	-	-
	T8315	0.4	160	0.15	1.3	95	0.14	1.3	150	0.15	1.3	480	0.18	1.3	40	0.12	1.0	30	0.15	1.0
	T8330	0.4	150	0.15	1.3	90	0.14	1.3	140	0.15	1.3	450	0.18	1.3	35	0.12	1.0	30	0.15	1.0
	T8430	0.4	180	0.15	1.3	95	0.14	1.3	145	0.15	1.3	495	0.18	1.3	35	0.12	1.0	30	0.15	1.0
	T9315	0.4	245	0.15	1.3	-	-	-	230	0.15	1.3	-	-	-	-	-	-	45	0.15	1.0
	T9325	0.4	210	0.17	1.3	125	0.15	1.3	195	0.17	1.3	-	-	-	45	0.15	1.0	-	-	-



Kesme hızı (vc), ilerleme (f) ve kesme derinliği (ap) için uygunluk ve başlangıç değerleri. Daha ileri hesaplamalar için İşleme Hesaplayıcısı uygulamasına başvurun.

Product	RE  (mm)	P			M			K			N			S			H		
		vc (m/min)	f (mm/rev)	ap (mm)	vc (m/min)	f (mm/rev)	ap (mm)	vc (m/min)	f (mm/rev)	ap (mm)	vc (m/min)	f (mm/rev)	ap (mm)	vc (m/min)	f (mm/rev)	ap (mm)	vc (m/min)	f (mm/rev)	ap (mm)

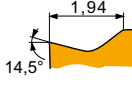

SF geometri, ince finiş ve ince cidar işlemek için pozitif tasarım, darbesiz kesim için uygun.

TNMG 160408E-SF	H07	0.8	–	–	–	85	0.15	1.3	140	0.17	1.3	445	0.20	1.3	45	0.14	1.0	–	–	–
	T6310	0.8	175	0.17	1.3	125	0.15	1.3	140	0.17	1.3	525	0.20	1.3	50	0.14	1.0	35	0.15	1.0
	T7325	0.8	200	0.17	1.3	155	0.15	1.3	–	–	–	–	–	–	65	0.15	1.0	–	–	–
	T7335	0.8	195	0.17	1.3	150	0.15	1.3	–	–	–	–	–	–	60	0.15	1.0	–	–	–
	T8315	0.8	185	0.17	1.3	110	0.15	1.3	175	0.17	1.3	555	0.20	1.3	45	0.14	1.0	35	0.15	1.0
	T8330	0.8	175	0.17	1.3	105	0.15	1.3	165	0.17	1.3	525	0.20	1.3	40	0.14	1.0	35	0.15	1.0
	T8430	0.8	205	0.17	1.3	110	0.15	1.3	170	0.17	1.3	570	0.20	1.3	45	0.14	1.0	35	0.15	1.0
	T9315	0.8	275	0.17	1.3	–	–	–	260	0.17	1.3	–	–	–	–	–	–	55	0.15	1.0
	T9325	0.8	250	0.17	1.3	150	0.15	1.3	235	0.17	1.3	–	–	–	55	0.15	1.0	–	–	–
	TNMG 160412E-SF	T6310	1.2	160	0.30	1.3	115	0.27	1.3	125	0.30	1.3	480	0.36	1.3	45	0.21	1.0	30	0.15
T7325		1.2	175	0.30	1.3	135	0.27	1.3	–	–	–	–	–	55	0.21	1.0	–	–	–	
T9325		1.2	205	0.30	1.3	120	0.27	1.3	190	0.30	1.3	–	–	–	45	0.21	1.0	–	–	–
TNMG 220404E-SF	T6310	0.4	145	0.17	1.7	100	0.15	1.7	115	0.17	1.7	435	0.20	1.7	40	0.15	1.4	25	0.15	1.0
	T7325	0.4	160	0.17	1.7	120	0.15	1.7	–	–	–	–	–	50	0.15	1.4	–	–	–	
	T9325	0.4	205	0.17	1.7	120	0.15	1.7	190	0.17	1.7	–	–	–	45	0.15	1.4	–	–	–
TNMG 220408E-SF	T6310	0.8	170	0.17	1.7	120	0.15	1.7	135	0.17	1.7	510	0.20	1.7	50	0.15	1.4	30	0.15	1.0
	T8315	0.8	180	0.17	1.7	105	0.15	1.7	170	0.17	1.7	540	0.20	1.7	45	0.15	1.4	35	0.15	1.0
	T8430	0.8	195	0.17	1.7	105	0.15	1.7	160	0.17	1.7	540	0.20	1.7	40	0.15	1.4	30	0.15	1.0
TNMG 220412E-SF	T6310	1.2	155	0.30	1.7	110	0.27	1.7	125	0.30	1.7	465	0.36	1.7	45	0.21	1.4	30	0.15	1.0
	T7325	1.2	170	0.30	1.7	130	0.27	1.7	–	–	–	–	–	55	0.21	1.4	–	–	–	
	T9325	1.2	205	0.30	1.7	120	0.27	1.7	190	0.30	1.7	–	–	–	45	0.21	1.4	–	–	–

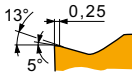

SM geometri, orta işleme için pozitif tasarım, darbesizden darbeli kesime kadar uygun.

TNMG 160404E-SM	T6310	0.4	135	0.22	1.7	95	0.20	1.7	105	0.22	1.7	405	0.26	1.7	40	0.20	1.4	25	0.15	1.0	
	T7325	0.4	150	0.22	1.7	115	0.20	1.7	–	–	–	–	–	45	0.20	1.4	–	–	–		
	T7335	0.4	145	0.22	1.7	110	0.20	1.7	–	–	–	–	–	45	0.20	1.4	–	–	–		
	T8330	0.4	135	0.22	1.7	80	0.20	1.7	125	0.22	1.7	405	0.26	1.7	30	0.20	1.4	25	0.15	1.0	
	T8430	0.4	145	0.22	1.7	80	0.20	1.7	120	0.22	1.7	405	0.26	1.7	30	0.20	1.4	25	0.15	1.0	
	T9315	0.4	210	0.20	1.7	–	–	–	195	0.20	1.7	–	–	–	–	–	–	40	0.15	1.0	
	T9325	0.4	185	0.22	1.7	110	0.20	1.7	175	0.22	1.7	–	–	–	40	0.20	1.4	–	–	–	
	TNMG 160408E-SM	T6310	0.8	150	0.25	1.7	105	0.23	1.7	120	0.25	1.7	450	0.30	1.7	45	0.20	1.4	30	0.15	1.0
		T7325	0.8	170	0.25	1.7	130	0.23	1.7	–	–	–	–	–	55	0.20	1.4	–	–	–	
		T7335	0.8	165	0.25	1.7	125	0.23	1.7	–	–	–	–	–	50	0.20	1.4	–	–	–	
T8330		0.8	150	0.25	1.7	90	0.23	1.7	140	0.25	1.7	450	0.30	1.7	35	0.20	1.4	30	0.15	1.0	
T8430		0.8	170	0.25	1.7	90	0.23	1.7	135	0.25	1.7	465	0.30	1.7	35	0.20	1.4	25	0.15	1.0	
T9315		0.8	230	0.25	1.7	–	–	–	215	0.25	1.7	–	–	–	–	–	–	45	0.15	1.0	
T9325		0.8	205	0.25	1.7	120	0.23	1.7	190	0.25	1.7	–	–	–	45	0.20	1.4	–	–	–	
TNMG 160412E-SM	T6310	1.2	155	0.30	1.7	110	0.27	1.7	125	0.30	1.7	465	0.36	1.7	45	0.24	1.4	30	0.15	1.0	
	T7325	1.2	170	0.30	1.7	130	0.27	1.7	–	–	–	–	–	55	0.24	1.4	–	–	–		
	T7335	1.2	165	0.30	1.7	125	0.27	1.7	–	–	–	–	–	50	0.24	1.4	–	–	–		
	T9325	1.2	205	0.30	1.7	120	0.27	1.7	190	0.30	1.7	–	–	–	45	0.24	1.4	–	–	–	
TNMG 220404E-SM	T6310	0.4	130	0.24	1.7	90	0.22	1.7	100	0.24	1.7	390	0.29	1.7	35	0.22	1.4	25	0.15	1.0	
	T7325	0.4	145	0.24	1.7	110	0.22	1.7	–	–	–	–	–	45	0.22	1.4	–	–	–		
	T8330	0.4	130	0.24	1.7	75	0.22	1.7	120	0.24	1.7	390	0.29	1.7	30	0.22	1.4	25	0.15	1.0	
	T8430	0.4	145	0.24	1.7	80	0.22	1.7	120	0.24	1.7	405	0.29	1.7	30	0.22	1.4	25	0.15	1.0	
	T9325	0.4	175	0.24	1.7	105	0.22	1.7	165	0.24	1.7	–	–	–	35	0.22	1.4	–	–	–	
TNMG 220408E-SM	T6310	0.8	150	0.25	1.7	105	0.23	1.7	120	0.25	1.7	450	0.30	1.7	45	0.20	1.4	30	0.15	1.0	
	T7325	0.8	170	0.25	1.7	130	0.23	1.7	–	–	–	–	–	55	0.20	1.4	–	–	–		
	T7335	0.8	165	0.25	1.7	125	0.23	1.7	–	–	–	–	–	50	0.20	1.4	–	–	–		
	T8330	0.8	150	0.25	1.7	90	0.23	1.7	140	0.25	1.7	450	0.30	1.7	35	0.20	1.4	30	0.15	1.0	
	T8430	0.8	170	0.25	1.7	90	0.23	1.7	135	0.25	1.7	465	0.30	1.7	35	0.20	1.4	25	0.15	1.0	
	T9315	0.8	230	0.25	1.7	–	–	–	215	0.25	1.7	–	–	–	–	–	–	45	0.15	1.0	
	T9325	0.8	205	0.25	1.7	120	0.23	1.7	190	0.25	1.7	–	–	–	45	0.20	1.4	–	–	–	



Kesme hızı (vc), ilerleme (f) ve kesme derinliği (ap) için uygunluk ve başlangıç değerleri. Daha ileri hesaplamalar için İşleme Hesaplayıcısı uygulamasına başvurun.

Product	RE (mm)	P			M			K			N			S			H		
		vc (m/min)	f (mm/rev)	ap (mm)	vc (m/min)	f (mm/rev)	ap (mm)	vc (m/min)	f (mm/rev)	ap (mm)	vc (m/min)	f (mm/rev)	ap (mm)	vc (m/min)	f (mm/rev)	ap (mm)	vc (m/min)	f (mm/rev)	ap (mm)

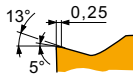

SM geometri, orta işleme için pozitif tasarım, darbesizden darbeli kesime kadar uygun.

TNMG 220412E-SM	T6310	1.2	155	0.30	1.7	110	0.27	1.7	125	0.30	1.7	465	0.36	1.7	45	0.24	1.4	30	0.15	1.0	
	T7325	1.2	170	0.30	1.7	130	0.27	1.7	-	-	-	-	-	-	55	0.24	1.4	-	-	-	
	T7335	1.2	165	0.30	1.7	125	0.27	1.7	-	-	-	-	-	-	50	0.24	1.4	-	-	-	
	T9315	1.2	225	0.30	1.7	-	-	-	210	0.30	1.7	-	-	-	-	-	-	-	45	0.15	1.0
	T9325	1.2	205	0.30	1.7	120	0.27	1.7	190	0.30	1.7	-	-	-	45	0.24	1.4	-	-	-	

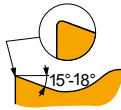

ER-SI geometri, çok pozitif sağ kesme yönlü tasarım, ince finişten yarı kaba işleme kadar, ve darbesiz kesim için uygun.

TNMG 160404ER-SI	T7325	0.4	190	0.20	1.5	145	0.18	1.5	-	-	-	-	-	-	60	0.18	1.2	-	-	-
	T7335	0.4	180	0.20	1.5	140	0.18	1.5	-	-	-	-	-	-	55	0.18	1.2	-	-	-
	T8315	0.4	175	0.20	1.5	105	0.18	1.5	-	-	-	525	0.24	1.5	40	0.18	1.2	-	-	-
	T8330	0.4	165	0.20	1.5	95	0.18	1.5	-	-	-	495	0.24	1.5	40	0.18	1.2	-	-	-
	T8430	0.4	185	0.20	1.5	100	0.18	1.5	-	-	-	510	0.24	1.5	40	0.18	1.2	-	-	-
	T9325	0.4	230	0.20	1.5	135	0.18	1.5	-	-	-	-	-	-	50	0.18	1.2	-	-	-
	T9335	0.4	195	0.20	1.5	115	0.18	1.5	-	-	-	-	-	-	40	0.18	1.2	-	-	-
TNMG 160408ER-SI	T7325	0.8	190	0.35	1.5	145	0.32	1.5	-	-	-	-	-	-	60	0.25	1.2	-	-	-
	T7335	0.8	180	0.35	1.5	140	0.32	1.5	-	-	-	-	-	-	55	0.25	1.2	-	-	-
	T8315	0.8	175	0.35	1.5	105	0.32	1.5	-	-	-	525	0.42	1.5	40	0.25	1.2	-	-	-
	T8330	0.8	170	0.35	1.5	100	0.32	1.5	-	-	-	510	0.42	1.5	40	0.25	1.2	-	-	-
	T8430	0.8	180	0.35	1.5	95	0.32	1.5	-	-	-	495	0.42	1.5	35	0.25	1.2	-	-	-
	T9325	0.8	215	0.35	1.5	125	0.32	1.5	-	-	-	-	-	-	45	0.25	1.2	-	-	-
	T9335	0.8	190	0.35	1.5	110	0.32	1.5	-	-	-	-	-	-	40	0.25	1.2	-	-	-

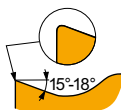

EL-SI geometri, çok pozitif sol kesme yönlü tasarım, ince finişten yarı kaba işleme kadar, ve darbesiz kesim için uygun.

TNMG 160404EL-SI	T7325	0.4	190	0.20	1.5	145	0.18	1.5	-	-	-	-	-	-	60	0.18	1.2	-	-	-
	T7335	0.4	180	0.20	1.5	140	0.18	1.5	-	-	-	-	-	-	55	0.18	1.2	-	-	-
	T8315	0.4	175	0.20	1.5	105	0.18	1.5	-	-	-	525	0.24	1.5	40	0.18	1.2	-	-	-
	T8330	0.4	165	0.20	1.5	95	0.18	1.5	-	-	-	495	0.24	1.5	40	0.18	1.2	-	-	-
	T8430	0.4	185	0.20	1.5	100	0.18	1.5	-	-	-	510	0.24	1.5	40	0.18	1.2	-	-	-
	T9325	0.4	230	0.20	1.5	135	0.18	1.5	-	-	-	-	-	-	50	0.18	1.2	-	-	-
	T9335	0.4	195	0.20	1.5	115	0.18	1.5	-	-	-	-	-	-	40	0.18	1.2	-	-	-
TNMG 160408EL-SI	T7325	0.8	190	0.35	1.5	145	0.32	1.5	-	-	-	-	-	-	60	0.25	1.2	-	-	-
	T7335	0.8	180	0.35	1.5	140	0.32	1.5	-	-	-	-	-	-	55	0.25	1.2	-	-	-
	T8315	0.8	175	0.35	1.5	105	0.32	1.5	-	-	-	525	0.42	1.5	40	0.25	1.2	-	-	-
	T8330	0.8	170	0.35	1.5	100	0.32	1.5	-	-	-	510	0.42	1.5	40	0.25	1.2	-	-	-
	T8430	0.8	180	0.35	1.5	95	0.32	1.5	-	-	-	495	0.42	1.5	35	0.25	1.2	-	-	-
	T9325	0.8	215	0.35	1.5	125	0.32	1.5	-	-	-	-	-	-	45	0.25	1.2	-	-	-
	T9335	0.8	190	0.35	1.5	110	0.32	1.5	-	-	-	-	-	-	40	0.25	1.2	-	-	-



TNMM

	IC	D1	L	S
	(mm)	(mm)	(mm)	(mm)
1604	9.525	3.81	16.50	4.76
2204	12.700	5.16	22.00	4.76
2706	15.875	6.35	27.50	6.35

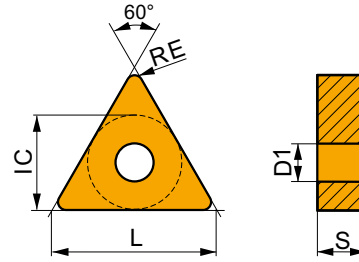

Kesme hızı (vc), ilerleme (f) ve kesme derinliği (ap) için uygunluk ve başlangıç değerleri. Daha ileri hesaplamalar için İşleme Hesaplayıcısı uygulamasına başvurun.

Product	RE	P			M			K			N			S			H		
		vc	f	ap	vc	f	ap	vc	f	ap	vc	f	ap	vc	f	ap	vc	f	ap
	(mm)	(m/min)	(mm/rev)	(mm)	(m/min)	(mm/rev)	(mm)	(m/min)	(mm/rev)	(mm)	(m/min)	(mm/rev)	(mm)	(m/min)	(mm/rev)	(mm)	(m/min)	(mm/rev)	(mm)

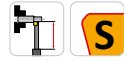
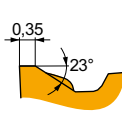

DR geometri, yarı kabadan kaba işleme, ve sürekliden aralıklı kesmeye kadar uygun.

TNMM 160408E-DR	T9325	0.8	175	0.40	4.0	105	0.36	4.0	165	0.40	4.0	-	-	-	-	-	-	-	-
TNMM 220408E-DR	T9325	0.8	175	0.40	4.0	105	0.36	4.0	165	0.40	4.0	-	-	-	-	-	-	-	-
	T9335	0.8	155	0.40	4.0	90	0.36	4.0	-	-	-	-	-	-	-	-	-	-	-
TNMM 220412E-DR	T9315	1.2	205	0.40	4.0	-	-	-	190	0.40	4.0	-	-	-	-	-	-	-	-
	T9325	1.2	185	0.40	4.0	110	0.36	4.0	175	0.40	4.0	-	-	-	-	-	-	-	-
	T9335	1.2	160	0.40	4.0	95	0.36	4.0	-	-	-	-	-	-	-	-	-	-	-
TNMM 220416E-DR	T9325	1.6	195	0.40	4.0	115	0.36	4.0	185	0.40	4.0	-	-	-	-	-	-	-	-
TNMM 270616E-DR	T9325	1.6	135	0.40	4.0	80	0.36	4.0	125	0.40	4.0	-	-	-	-	-	-	-	-
	T9335	1.6	110	0.40	4.0	65	0.36	4.0	-	-	-	-	-	-	-	-	-	-	-

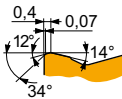

HR geometri, kapadan ağır kaba işleme kadar, darbesizden darbeli kesime kadar uygun.

TNMM 270616E-HR	T9325	1.6	90	0.60	7.0	50	0.54	7.0	85	0.60	7.0	-	-	-	-	-	-	-	-
	T9335	1.6	75	0.60	7.0	45	0.54	7.0	-	-	-	-	-	-	-	-	-	-	-
TNMM 270624E-HR	T9226	2.4	80	0.65	7.0	45	0.59	7.0	75	0.65	7.0	-	-	-	-	-	-	-	-

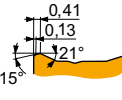

NR2 geometri, yarı kabadan kaba işleme kadar, darbesizden darbeli kesime kadar uygun.

TNMM 160408E-NR2	T9325	0.8	165	0.40	3.0	95	0.36	3.0	155	0.40	3.0	-	-	-	35	0.28	2.4	-	-
TNMM 220408E-NR2	T7325	0.8	145	0.40	4.0	110	0.36	4.0	-	-	-	-	-	-	45	0.28	3.2	-	-
	T9325	0.8	160	0.40	4.0	95	0.36	4.0	150	0.40	4.0	-	-	-	35	0.28	3.2	-	-
TNMM 220412E-NR2	T7325	1.2	150	0.40	4.0	115	0.36	4.0	-	-	-	-	-	-	45	0.32	3.2	-	-
	T8330	1.2	135	0.40	4.0	80	0.36	4.0	125	0.40	4.0	-	-	-	30	0.32	3.2	-	-
	T8430	1.2	140	0.40	4.0	75	0.36	4.0	115	0.40	4.0	-	-	-	30	0.32	3.2	-	-
	T9325	1.2	170	0.40	4.0	100	0.36	4.0	160	0.40	4.0	-	-	-	35	0.32	3.2	-	-

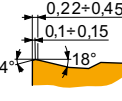

OR geometri, orta kabadan kabaya kadar işlemek için, darbesizden darbeli kesime kadar uygun.

TNMM 160408E-OR	T9315	0.8	185	0.40	3.0	-	-	-	175	0.40	3.0	-	-	-	-	-	-	-	-
	T9325	0.8	165	0.40	3.0	95	0.36	3.0	155	0.40	3.0	-	-	-	35	0.28	2.4	-	-
TNMM 160412E-OR	T9325	1.2	175	0.40	3.0	105	0.36	3.0	165	0.40	3.0	-	-	-	35	0.32	2.4	-	-
TNMM 220408E-OR	T9315	0.8	180	0.40	4.0	-	-	-	170	0.40	4.0	-	-	-	-	-	-	-	-
	T9325	0.8	160	0.40	4.0	95	0.36	4.0	150	0.40	4.0	-	-	-	35	0.32	3.2	-	-
	T9335	0.8	140	0.40	4.0	80	0.36	4.0	-	-	-	-	-	-	30	0.32	3.2	-	-
TNMM 220412E-OR	T9325	1.2	175	0.40	3.0	105	0.36	3.0	165	0.40	3.0	-	-	-	35	0.32	2.4	-	-
	T9335	1.2	150	0.40	3.0	90	0.36	3.0	-	-	-	-	-	-	30	0.32	2.4	-	-



Kesme hızı (vc), ilerleme (f) ve kesme derinliği (ap) için uygunluk ve başlangıç değerleri. Daha ileri hesaplamalar için İşleme Hesaplayıcısı uygulamasına başvurun.

Product	RE (mm)	P			M			K			N			S			H		
		vc (m/min)	f (mm/rev)	ap (mm)	vc (m/min)	f (mm/rev)	ap (mm)	vc (m/min)	f (mm/rev)	ap (mm)	vc (m/min)	f (mm/rev)	ap (mm)	vc (m/min)	f (mm/rev)	ap (mm)	vc (m/min)	f (mm/rev)	ap (mm)

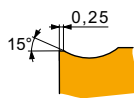

ER geometri, sağ kesme yönlü tasarım, orta ve yarı kaba işlemeye kadar, ve darbesiz kesim için uygun.

TNMM 220412ER	T9335	1.2	190	0.35	2.1	110	0.32	2.1	-	-	-	-	-	-	40	0.25	1.7	-	-	-
---------------	-------	-----	-----	------	-----	-----	------	-----	---	---	---	---	---	---	----	------	-----	---	---	---

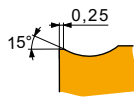

EL geometri, sol kesme yönlü tasarım, orta ve yarı kaba işlemeye kadar, ve darbesiz kesim için uygun.

TNMM 220412EL	T9335	1.2	190	0.35	2.1	110	0.32	2.1	-	-	-	-	-	40	0.25	1.7	-	-	-
---------------	-------	-----	-----	------	-----	-----	------	-----	---	---	---	---	---	----	------	-----	---	---	---

TNGA CER



	IC (mm)	D1 (mm)	L (mm)	S (mm)
1604	9.525	3.81	16.50	4.76

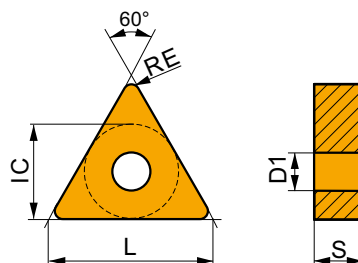

Kesme hızı (vc), ilerleme (f) ve kesme derinliği (ap) için uygunluk ve başlangıç değerleri. Daha ileri hesaplamalar için İşleme Hesaplayıcısı uygulamasına başvurun.

Product	RE (mm)	P			M			K			N			S			H		
		vc (m/min)	f (mm/rev)	ap (mm)	vc (m/min)	f (mm/rev)	ap (mm)	vc (m/min)	f (mm/rev)	ap (mm)	vc (m/min)	f (mm/rev)	ap (mm)	vc (m/min)	f (mm/rev)	ap (mm)	vc (m/min)	f (mm/rev)	ap (mm)

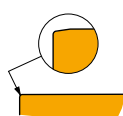

Yüksek hızlı işleme ve darbesiz kesme için.

TNGA 160408 T01020	TC100	0.8	-	-	-	-	-	-	475	0.20	1.5	-	-	-	-	-	-	-	-	-
TNGA 160412 T01020	TC100	1.2	-	-	-	-	-	-	500	0.20	1.5	-	-	-	-	-	-	-	-	-



TNGN CER

	IC	L	S
	(mm)	(mm)	(mm)
1604	9.525	16.50	4.76
1607	9.525	16.50	7.94

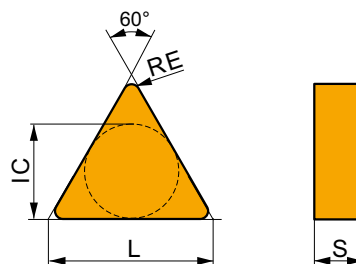

Kesme hızı (vc), ilerleme (f) ve kesme derinliği (ap) için uygunluk ve başlangıç değerleri. Daha ileri hesaplamalar için İşleme Hesaplayıcısı uygulamasına başvurun.

Product	RE	P			M			K			N			S			H		
		vc	f	ap	vc	f	ap	vc	f	ap	vc	f	ap	vc	f	ap			
	(mm)	(m/min)	(mm/rev)	(mm)	(m/min)	(mm/rev)	(mm)	(m/min)	(mm/rev)	(mm)	(m/min)	(mm/rev)	(mm)	(m/min)	(mm/rev)	(mm)	(m/min)	(mm/rev)	(mm)

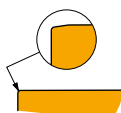

Yüksek hızlı işleme ve darbesiz kesme için.

TNGN 160408 T01020	TC100	0.8	-	-	-	-	-	-	475	0.20	1.5	-	-	-	-	-	-	-	-
TNGN 160412 T01020	TC100	1.2	-	-	-	-	-	-	500	0.20	1.5	-	-	-	-	-	-	-	-
TNGN 160708 T02020	TC100	0.8	-	-	-	-	-	-	475	0.20	1.5	-	-	-	-	-	-	-	-

TNGA CBN

	IC	D1	L	S
	(mm)	(mm)	(mm)	(mm)
1604	9.525	3.81	16.50	4.76

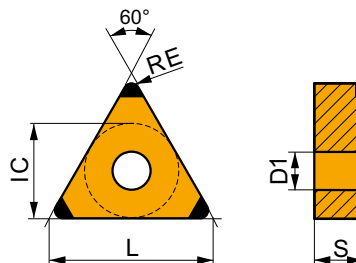

Kesme hızı (vc), ilerleme (f) ve kesme derinliği (ap) için uygunluk ve başlangıç değerleri. Daha ileri hesaplamalar için İşleme Hesaplayıcısı uygulamasına başvurun.

Product	RE	P			M			K			N			S			H		
		vc	f	ap	vc	f	ap	vc	f	ap	vc	f	ap	vc	f	ap			
	(mm)	(m/min)	(mm/rev)	(mm)	(m/min)	(mm/rev)	(mm)	(m/min)	(mm/rev)	(mm)	(m/min)	(mm/rev)	(mm)	(m/min)	(mm/rev)	(mm)	(m/min)	(mm/rev)	(mm)

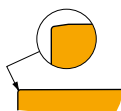

Finiş işleme ve darbesiz kesme için.

TNGA 160408S01020C	TB310	0.8	-	-	-	-	-	-	450	0.15	0.6	-	-	-	115	0.11	0.5	95	0.15	1.0
--------------------	-------	-----	---	---	---	---	---	---	-----	------	-----	---	---	---	-----	------	-----	----	------	-----



DTFN(RL) EXT



PRAMET

D



TN.. Uç için Çift Sıklımlı 91° (Alın) Dış Kateri

Çift sıklımlı 91° Sağ/Sol dış kater. Negatif TN.. 16 veya 22 uçlarla alın, ve pah tornalama için uygundur. 20x20 and 25x25mm şaft ölçüleri. Gövde uzun takım ömrü için işlem görmüştür.

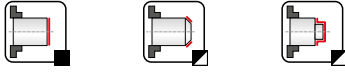
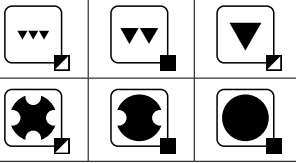
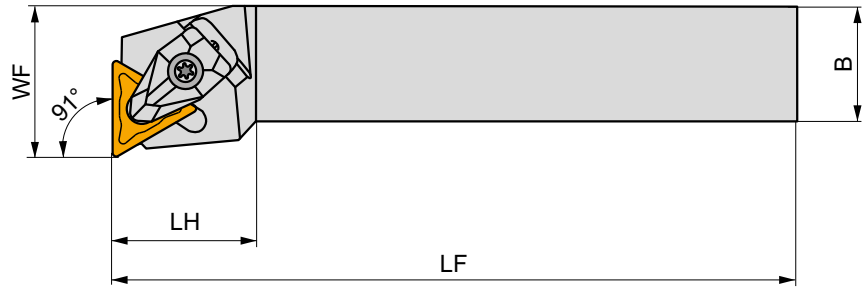
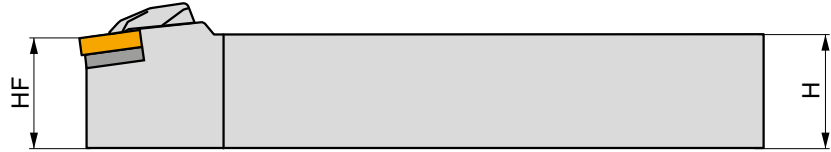
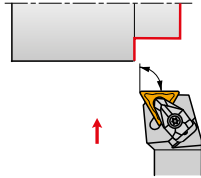

Product	H	B	HF	WF	LF	LH	LAMS	GAMO	kg	GI024	DT16	
	(mm)	(mm)	(mm)	(mm)	(mm)	(mm)	(°)	(°)				
R	DTFNR 2020 K 16	20	20	20	25	125	23.6	-6	-6	0.43	GI024	DT16
	DTFNR 2525 M 16	25	25	25	32	150	23.6	-6	-6	0.77	GI024	DT16
	DTFNR 2525 M 22	25	25	25	32	150	30.5	-6	-6	0.79	GI025	DT22
L	DTFNL 2020 K 16	20	20	20	25	125	23.6	-6	-6	0.43	GI024	DT16
	DTFNL 2525 M 16	25	25	25	32	150	23.6	-6	-6	0.76	GI024	DT16
	DTFNL 2525 M 22	25	25	25	32	150	30.5	-6	-6	0.79	GI025	DT22



GI024

TN.. 1604..

GI025

TN.. 2204..



DT16

DCS 09

1.7

DTS 315-02

US 2004-T09P

FLAG T09P

DT22

DCS 12

3.9

DTS 315-04

US 2002-T15P

FLAG T15P/3,5



DTGN(RL) EXT



PRAMET

D



TN.. Uç için Çift Sıkmalı 91° Dış Kateri

Çift sıkmalı 91° Sağ/Sol dış kater. Negatif TN.. 16 veya 22 uçlarla çap, kopya, konik ve pah tornalama için uygundur. 20x20 - 40x40mm shaft ölçüleri. Gövde uzun takım ömrü için işlem görmüştür.

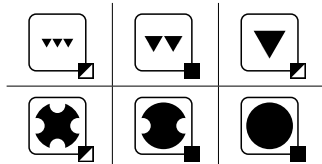
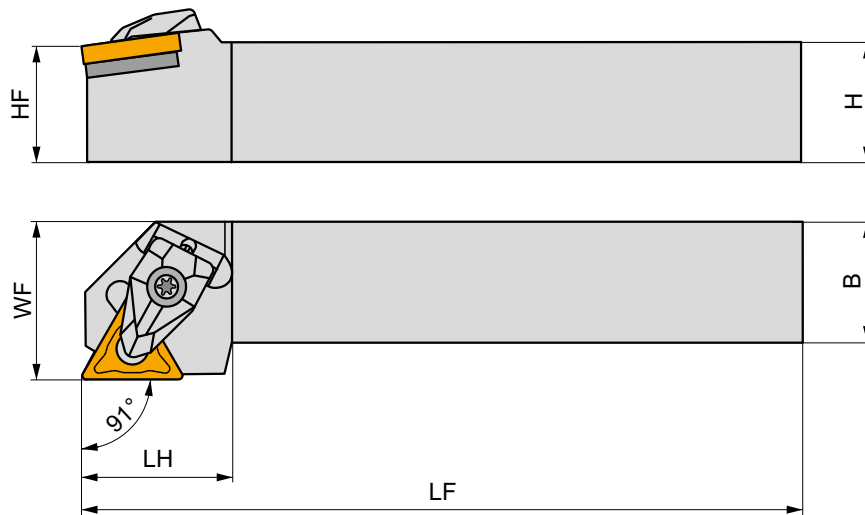
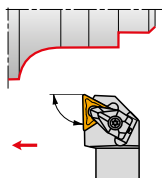

Product	H	B	HF	WF	LF	LH	LAMS	GAMO	kg	GI024	DT16
	(mm)	(mm)	(mm)	(mm)	(mm)	(mm)	(°)	(°)			
R DTGNR 2020 K 16	20	20	20	25	125	25.4	-6	-6	0.43	GI024	DT16
DTGNR 2525 M 16	25	25	25	32	150	24.6	-6	-6	0.76	GI024	DT16
DTGNR 2525 M 22	25	25	25	32	150	32.1	-6	-6	0.83	GI025	DT22
DTGNR 3232 P 22	32	32	32	40	170	33.1	-6	-6	1.42	GI025	DT22
L DTGNL 2020 K 16	20	20	20	25	125	25.4	-6	-6	0.44	GI024	DT16
DTGNL 2525 M 16	25	25	25	32	150	24.6	-6	-6	0.78	GI024	DT16
DTGNL 2525 M 22	25	25	25	32	150	32.1	-6	-6	0.78	GI025	DT22
DTGNL 3232 P 22	32	32	32	40	170	33.1	-6	-6	1.42	GI025	DT22



GI024

TN.. 1604..

GI025

TN.. 2204..



DT16

DCS 09

1.7

DTS 315-02

US 2004-T09P

FLAG T09P

DT22

DCS 12

3.9

DTS 315-04

US 2002-T15P

FLAG T15P/3,5



MTJN(RL) EXT

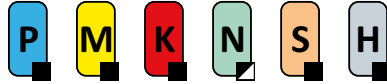

PRAMET

M



WN.. Uç için Pabuçlu 93° Açılı Dış Kater

Pabuçlu, 93° açılı Sağ/Sol dış kater. Negatif TN.. 16 veya 22 uçlarla çap, 22°'ye kadar kopya, konik ve pah tornalamak için uygundur. 20x20'den 32x32mm'ye kadar mevcuttur. Gövde uzun takım ömrü için işlem görmüştür.

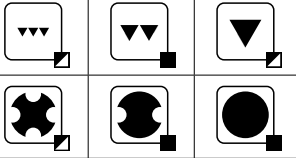
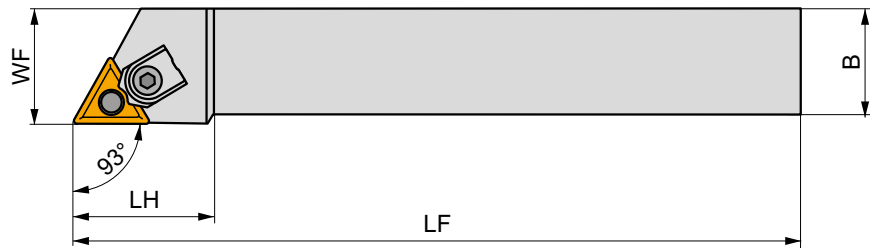
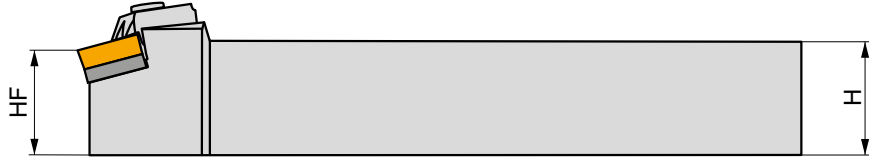
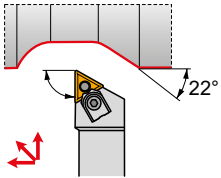

Product	H	B	HF	WF	LF	LH	LAMS	GAMO	kg	GI024	GI025	
	(mm)	(mm)	(mm)	(mm)	(mm)	(mm)	(°)	(°)				
R	MTJNR 2020 K 16	20	20	20	25	125	34	-6	-6	0.42	GI024	MT16
	MTJNR 2525 M 16	25	25	25	32	150	34	-6	-6	0.73	GI024	MT16
	MTJNR 3232 P 22	32	32	32	40	175	42	-6	-6	1.37	GI025	MT22
L	MTJNL 2020 K 16	20	20	20	25	125	34	-6	-6	0.43	GI024	MT16
	MTJNL 2525 M 16	25	25	25	32	150	34	-6	-6	0.75	GI024	MT16
	MTJNL 3232 P 22	32	32	32	40	175	42	-6	-6	1.38	GI025	MT22



GI024

TN.. 1604..

GI025

TN.. 2204..



MT16

UE 16

3.0

MTN 160312

UC 52

HS 93

HXK 5

MT22

UE 22

5.0

MTN 220612

UC 53

HS 94

HXK 5



PTFN(RL) EXT

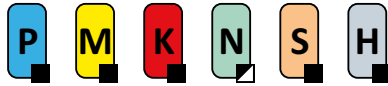

PRAMET

P



SN.. Uç için Levveli 90° Açılı (Alın) Dış Kater

Levveli, 90° açılı Sağ/Sol dış kater. Negatif TN 16, 22 veya 27 uçlarla alın ve pah tornalamak için uygundur. 16x16'dan 40x40mm'ye kadar mevcuttur. Gövde uzun takım ömrü için işlem görmüştür.

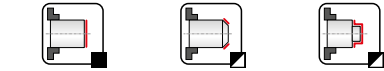
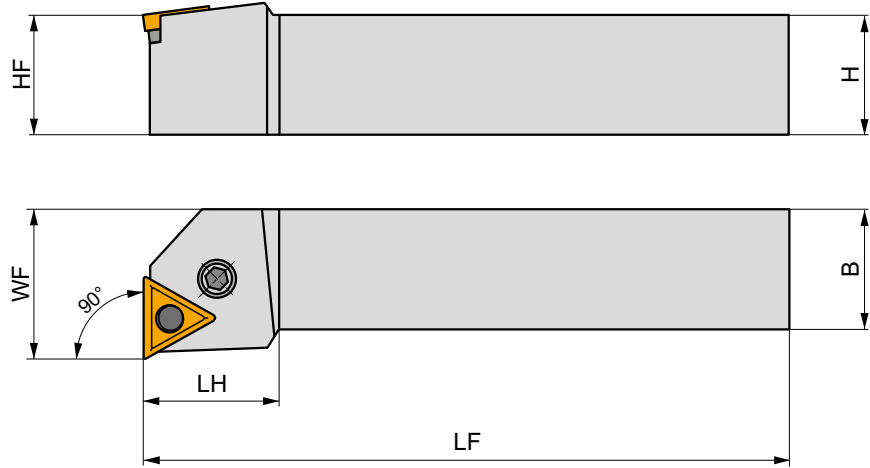
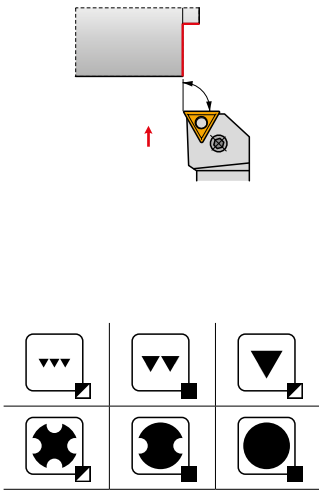

Product	H	B	HF	WF	LF	LH	LAMS	GAMO	kg	G1024	G1025	G1077
	(mm)	(mm)	(mm)	(mm)	(mm)	(mm)	(°)	(°)				
R	PTFNR 1616 H 16	16	16	16	20	100	32	-6	-6	0.23	G1024	PT11
	PTFNR 2020 K 16	20	20	20	25	125	32	-6	-6	0.44	G1024	PT10
	PTFNR 2525 M 16	25	25	25	32	150	32	-6	-6	0.76	G1024	PT10
	PTFNR 2525 M 22	25	25	25	32	150	36	-6	-6	0.79	G1025	PT20
	PTFNR 3225 P 22	32	25	32	32	170	36	-6	-6	1.05	G1025	PT20
PTFNR 4040 R 27	40	40	40	50	200	40	-6	-6	2.55	G1077	PT40	
L	PTFNL 1616 H 16	16	16	16	20	100	32	-6	-6	0.24	G1024	PT11
	PTFNL 2020 K 16	20	20	20	25	125	32	-6	-6	0.43	G1024	PT10
	PTFNL 2525 M 16	25	25	25	32	150	32	-6	-6	0.65	G1024	PT10
	PTFNL 2525 M 22	25	25	25	32	150	36	-6	-6	0.79	G1025	PT20
	PTFNL 3225 P 22	32	25	32	32	170	36	-6	-6	1.14	G1025	PT20
PTFNL 4040 R 27	40	40	40	50	200	40	-6	-6	2.55	G1077	PT40	



G1024

TN.. 1604..

G1025

TN.. 2204..

G1077

TN.. 2706..



PT10

TNU 160308

PU 01

US 34

5.0

M 6x0.75

19

NT 04

MT 04

HXK 3

PT11

TNU 160308

PU 01

US 46

5.0

M 6x0.75

13.2

NT 04

MT 04

HXK 3

PT20

TNU 220312

PU 02

US 35

6.0

M 8x1

22.5

NT 05

MT 05

HXK 4

PT40

TNU 270416

PU 04

US 36

6.0

M 8x1

26

NT 07

MT 07

HXK 4



PTGN(RL) EXT

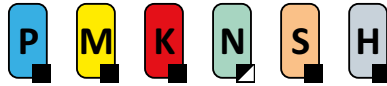

PRAMET

P



SN.. Uç için Levveli 90° Açılı Dış Kater

Levveli, 90° açılı Sağ/Sol dış kater. Negatif TN 16, 22 veya 27 uçlarla çap, konik ve pah tornalamak için uygundur. 16x16'dan 40x40mm'ye kadar mevcuttur. Gövde uzun takım ömrü için işlem görmüştür.

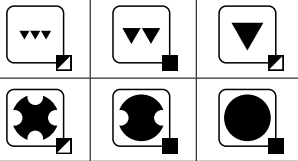
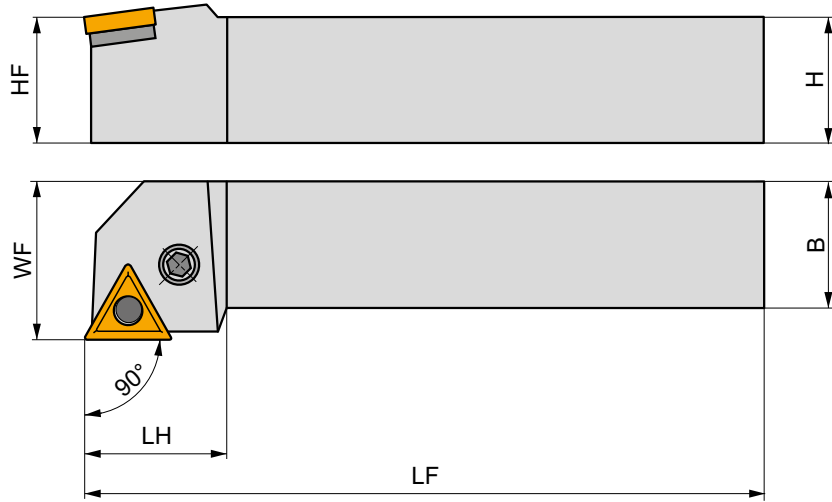
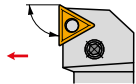

Product	H (mm)	B (mm)	HF (mm)	WF (mm)	LF (mm)	LH (mm)	LAMS (°)	GAMMO (°)	kg	GI024	GI025	PT10	PT11	PT20	PT40
R PTGNR 1616 H 16	16	16	16	20	100	32	-6	-6	0.24	GI024	PT11				
PTGNR 2020 K 16	20	20	20	25	125	32	-6	-6	0.40	GI024	PT10				
PTGNR 2525 M 16	25	25	25	32	150	32	-6	-6	0.73	GI024	PT10				
PTGNR 2525 M 22	25	25	25	32	150	36	-6	-6	0.75	GI025	PT20				
PTGNR 3225 P 22	32	25	32	32	170	36	-6	-6	1.11	GI025	PT20				
PTGNR 3232 P 22	32	32	32	40	170	36	-6	-6	1.39	GI025	PT20				
PTGNR 4040 R 27	40	40	40	50	200	40	-6	-6	2.55	GI077	PT40				
L PTGNL 1616 H 16	16	16	16	20	100	32	-6	-6	0.25	GI024	PT11				
PTGNL 2020 K 16	20	20	20	25	125	32	-6	-6	0.40	GI024	PT10				
PTGNL 2525 M 16	25	25	25	32	150	32	-6	-6	0.77	GI024	PT10				
PTGNL 2525 M 22	25	25	25	32	150	36	-6	-6	0.79	GI025	PT20				
PTGNL 3225 P 22	32	25	32	32	170	36	-6	-6	1.11	GI025	PT20				
PTGNL 3232 P 22	32	32	32	40	170	36	-6	-6	1.40	GI025	PT20				
PTGNL 4040 R 27	40	40	40	50	200	40	-6	-6	2.40	GI077	PT40				



GI024

TN.. 1604..

GI025

TN.. 2204..

GI077

TN.. 2706..



PT10

TNU 160308

PU 01

US 34

5.0

M 6x0.75

19

NT 04

MT 04

HXX 3

PT11

TNU 160308

PU 01

US 46

5.0

M 6x0.75

13.2

NT 04

MT 04

HXX 3

PT20

TNU 220312

PU 02

US 35

6.0

M 8x1

22.5

NT 05

MT 05

HXX 4

PT40

TNU 270416

PU 04

US 36

6.0

M 8x1

26

NT 07

MT 07

HXX 4



PTTN(RL) EXT

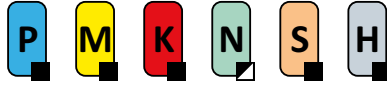

PRAMET

P



TN.. Uç için Levveli 60° Açılı Dış Kater

Levyeli, 60° açılı Sağ/Sol dış kater. Negatif TN.. 16 ve 22 uçlarla çap, 30°'ye kadar kopya, konik ve pah tornalamak için uygundur. 20x20'den 32x25'e kadar mevcuttur. Gövde uzun takım ömrü için işlem görmüştür.

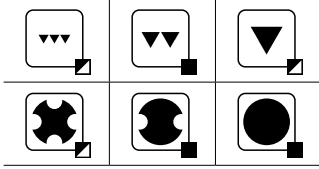
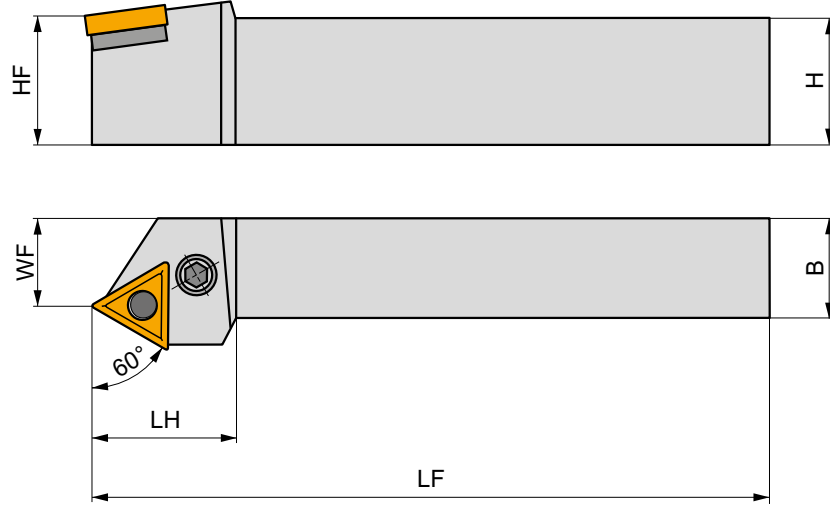
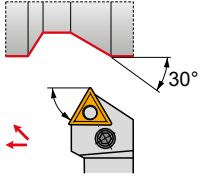

Product	H	B	HF	WF	LF	LH	LAMS	GAMO	kg		
	(mm)	(mm)	(mm)	(mm)	(mm)	(mm)	(°)	(°)			
R PTTNR 2020 K 16	20	20	20	17	125	32	-6	-6	0.43	GI024	PT10
PTTNR 2525 M 16	25	25	25	22	150	32	-6	-6	0.63	GI024	PT10
PTTNR 2525 M 22	25	25	25	22	150	36	-6	-6	0.73	GI025	PT20
PTTNR 3225 P 22	32	25	32	22	170	36	-6	-6	1.07	GI025	PT20
L PTTNL 2020 K 16	20	20	20	17	125	32	-6	-6	0.38	GI024	PT10
PTTNL 3225 P 22	32	25	32	22	170	36	-6	-6	1.04	GI025	PT20



GI024
GI025

TN.. 1604..
TN.. 2204..



PT10
PT20

TNU 160308
TNU 220312

PU 01
PU 02

US 34
US 35

5.0
6.0

M 6x0.75
M 8x1

19
22.5

NT 04
NT 05

MT 04
MT 05

HXK 3
HXK 4

NEW
C.-DTJN(RL) EXT

PRAMET
D

TN.. Uç için Çift Sıkmalı, 93° Açılı Hızlı Değişirme Dış Takımı

Çift sıkmalı, 93° açılı, içten su vermeli Sağ/Sol dış kater. Negatif TN.. 16 uçlarla çap, alın, konik ve pah tornalamak için uygundur. C4 ve C5 PSC şaftlı mevcuttur. Tutucu uzun takım ömrü için işlem görmüştür.

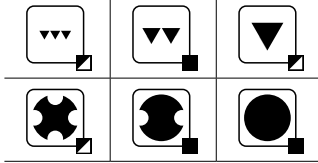
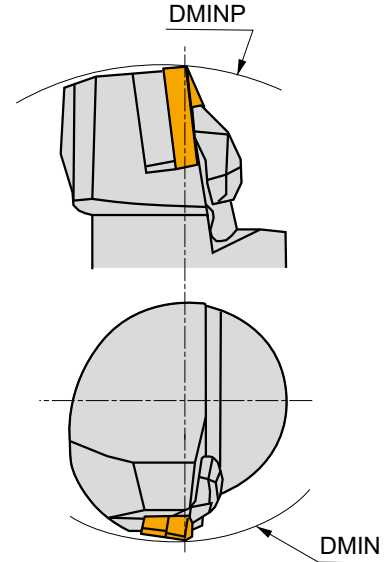
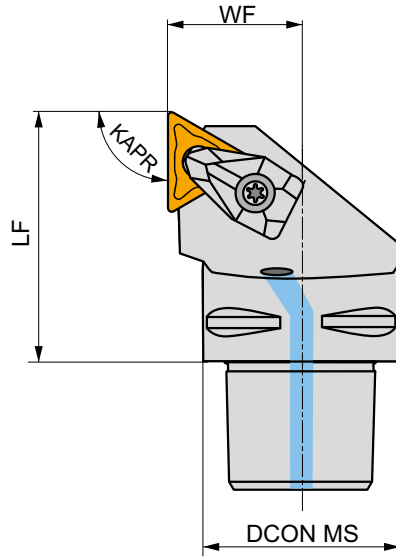
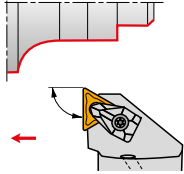

Product	DCON MS (mm)	DMIN (mm)	DMINP (mm)	WF (mm)	LF (mm)	KAPR (°)	LAMS (°)	GAMO (°)	✓	kg	GI024	C-DT16
R C4-DTJNR-27050-16	40	110	140	27	50	93	-6	-6	✓	0.43	GI024	C-DT16
	C5-DTJNR-35060-16	50	110	165	35	60	93	-6	-6	✓	0.79	GI024
L C4-DTJNL-27050-16	40	110	140	27	50	93	-6	-6	✓	0.44	GI024	C-DT16
	C5-DTJNL-35060-16	50	110	165	35	60	93	-6	-6	✓	0.79	GI024



GI024



TN.. 1604..



C-DT16



DCS 09



1.7



DTS 315-02



US 2004-T09P



FLAG T09P



CN 045-01



DTFN(RL) INT



PRAMET

D



TN.. Uç için Çift Sıkmalı 91° Açılı Delik Kateri

Çift sıkmalı 91° Sağ/Sol içten su vermeli delik kateri. Negatif TN.. 16 veya 22 uçlarla minimum Ø32mm çap, konik ve pah tornalama için uygundur. Ø25-40mm shaft ölçüleri. Gövde uzun takım ömrü için işlem görmüştür.

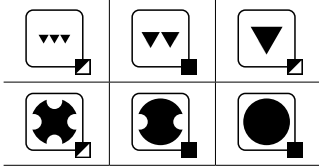
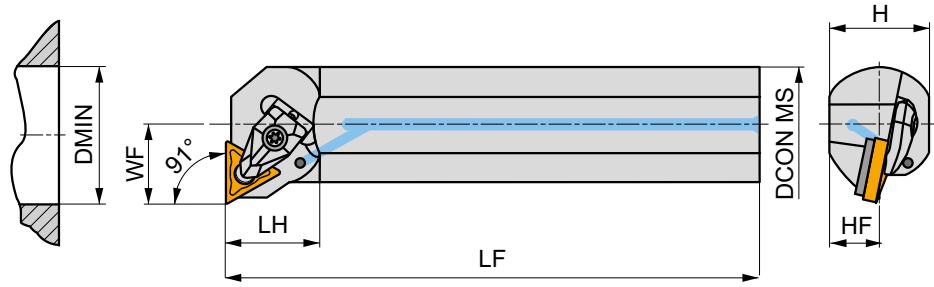
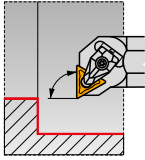

Product	DCON MS (mm)	DMIN (mm)	WF (mm)	H (mm)	HF (mm)	LF (mm)	LH (mm)	LAMS (°)	GAMO (°)				
R A25T-DTFNR 16	25	32	17	23	11.5	300	32	-12	-6	✓	0.96	G1024	DT116
A32T-DTFNR 16	32	40	22	30	15	300	33	-10	-6	✓	1.67	G1024	DT116
A40T-DTFNR 22	40	50	27	37	18.5	300	36	-13	-6	✓	2.58	G1025	DT22
L A25T-DTFNL 16	25	32	17	23	11.5	300	32	-12	-6	✓	0.96	G1024	DT116
A32T-DTFNL 16	32	40	22	30	15	300	33	-10	-6	✓	1.67	G1024	DT116
A40T-DTFNL 22	40	50	27	37	18.5	300	36	-13	-6	✓	2.58	G1025	DT22



G1024

G1025



TN.. 1604..

TN.. 2204..



DT22

DT116



DCS 12

DCS 09



3.9

1.7



DTS 315-04

DTS 316-01



US 2002-T15P

US 2004-T09P



FLAG T15P/3,5

FLAG T09P



PTFN(RL) INT

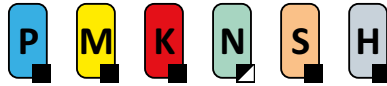

PRAMET

P



TN.. Uç için Levye 90° Açılı Delik Kateri

Vida sıkmalı Sağ/Sol 95° içten su vermeli karbür delik kateri. Pozitif EP.. 0502 uçlarla minimum Ø20mm çap, konik ve pah tornalama için uygundur. Ø8-16mm shaft ölçülerinde bulunur. Gövde uzun takım ömrü için işlem görmüştür. Delik boyu > 3xD

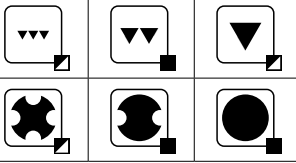
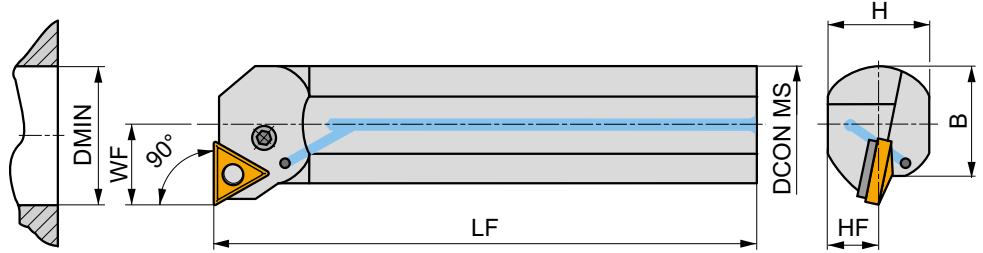
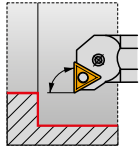

Product	DCON MS	DMIN	WF	H	B	LF	LAMS	GAMO		kg			
	(mm)	(mm)	(mm)	(mm)	(mm)	(mm)	(°)	(°)					
R	A25R-PTFNR 16	25	32	17	23	23	200	-12	-6	✓	0.74	GI024	PT11
	A32S-PTFNR 16	32	40	22	30	30	250	-12	-6	✓	1.49	GI024	PT10
	A40T-PTFNR 22	40	50	27	38	38	300	-12	-6	✓	2.58	GI025	PT20
L	A25R-PTFNL 16	25	32	17	23	23	200	-12	-6	✓	0.74	GI024	PT11
	A32S-PTFNL 16	32	40	22	30	30	250	-12	-6	✓	1.48	GI024	PT10
	A40T-PTFNL 22	40	50	27	38	38	300	-12	-6	✓	2.90	GI025	PT20



GI024

TN.. 1604..

GI025

TN.. 2204..



PT10

TNU 160308

PU 01

US 34

5.0

M 6x0.75

19

NT 04

MT 04

HXK 3

PT11

TNU 160308

PU 01

US 46

5.0

M 6x0.75

13.2

NT 04

MT 04

HXK 3

PT20

TNU 220312

PU 02

US 35

6.0

M 8x1

22.5

NT 05

MT 05

HXK 4

NEW
C.-DTFN(RL) INT

PRAMET
D

TN.. Uçlar için Çift Sıkmalı 91° Açılı PSC Hızlı Değişirme Delik Takımı

Çift sıkmalı 91° Sağ/Sol içten su vermeli delik kateri. Negatif TN.. 16 uçlarla minimum Ø32mm çap, ve birçok çeşit tormalama için uygundur. PSC C4 şaft ve 68mm boy ölçüleri. Gövde uzun takım ömrü için işlem görmüştür.

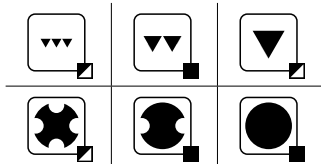
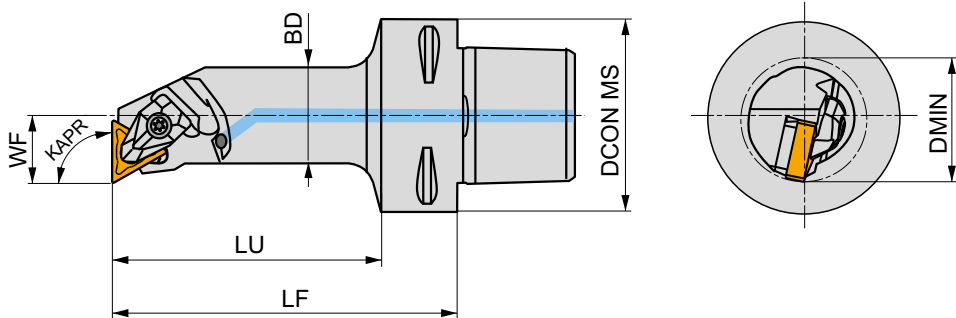
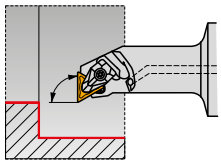

Product	DCON MS (mm)	DMIN (mm)	WF (mm)	LF (mm)	LU (mm)	BD (mm)	KAPR (°)	LAMS (°)	GAMO (°)				
R C4-DTFNR-17090-16	40	32	17	90	68	25	91	-12	-6	✓	0.51	GI024	DTI16

	GI024												
							TN.. 1604..						

DTI16	DCS 09	1.7		DTS 316-01		US 2004-T09P						FLAG T09P	



KARBÜR UÇLAR

VNMG



356

CER VE CBN UÇLAR

VNGA CER



359

VNGA CBN



359

DOĞRU BOYUTLA EŞLEŞTİRİN (örnek)

Kesici uç

VNMG 160404E-SF

Takım Tutucu

DVJNL 2020 K 16

ISO TORNALAMA - DIŞ

DVJN(RL) EXT

93°

VN..

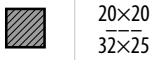
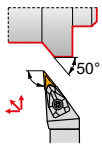

16

20×20
32×25

360

356 – 359

DVPN(RL) EXT

62°30'

VN..

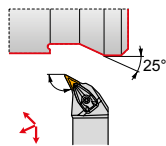

16

20×20
32×25

361

356 – 359

MVJN(RL) EXT

93°

VN..

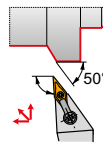

16

20×20
32×25

362

356 – 359

C.-DVJN(RL) EXT **NEW**

93°

VN..

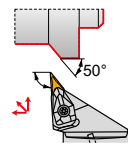

16

C4
C6

363

356 – 359

ISO TORNALAMA - İÇ

DVUN(RL) INT

VN..



16

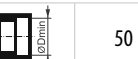
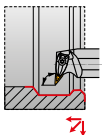

50

364

356 – 359



VNMG

	IC	D1	L	S
	(mm)	(mm)	(mm)	(mm)
1604	9.525	3.81	16.60	4.76

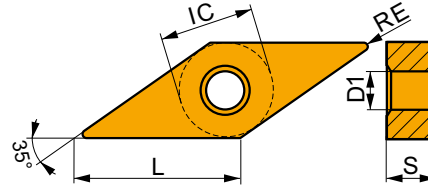

Kesme hızı (vc), ilerleme (f) ve kesme derinliği (ap) için uygunluk ve başlangıç değerleri. Daha ileri hesaplamalar için İşleme Hesaplayıcısı uygulamasına başvurun.

Product	RE (mm)	P			M			K			N			S			H		
		vc (m/min)	f (mm/rev)	ap (mm)	vc (m/min)	f (mm/rev)	ap (mm)	vc (m/min)	f (mm/rev)	ap (mm)	vc (m/min)	f (mm/rev)	ap (mm)	vc (m/min)	f (mm/rev)	ap (mm)	vc (m/min)	f (mm/rev)	ap (mm)

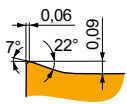

FF geometri, ince-finiş işleme için çok pozitif tasarım, darbesizden hafif darbeleri işlemeye kadar uygun.

VNMG 160404E-FF	T7325	0.4	165	0.12	1.0	125	0.11	1.0	–	–	–	–	–	–	–	–	–	–
	T8315	0.4	150	0.12	1.0	90	0.11	1.0	140	0.12	1.0	–	–	–	–	–	–	–
	T8330	0.4	140	0.12	1.0	80	0.11	1.0	130	0.12	1.0	–	–	–	–	–	–	–
	T8430	0.4	175	0.12	1.0	95	0.11	1.0	140	0.12	1.0	–	–	–	–	–	–	–

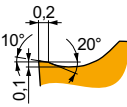

FM pozitif geometri, finiştan yarı kaba işlemeye, ve darbesizden hafif darbeleri kesmeye kadar uygun.

VNMG 160404E-FM	T7325	0.4	140	0.20	1.2	105	0.18	1.2	–	–	–	45	0.20	1.0	–	–	–
	T8330	0.4	120	0.20	1.2	70	0.18	1.2	110	0.20	1.2	30	0.14	1.0	–	–	–
	T8430	0.4	135	0.20	1.2	75	0.18	1.2	110	0.20	1.2	25	0.14	1.0	–	–	–
	T9310	0.4	210	0.20	1.2	–	–	–	195	0.20	1.2	–	–	–	–	–	–
	T9315	0.4	190	0.20	1.2	–	–	–	180	0.20	1.2	–	–	–	–	–	–
	T9325	0.4	170	0.20	1.2	100	0.18	1.2	160	0.20	1.2	35	0.20	1.0	–	–	–
VNMG 160408E-FM	T7325	0.8	160	0.20	1.4	120	0.18	1.4	–	–	–	50	0.16	1.1	–	–	–
	T8330	0.8	145	0.20	1.4	85	0.18	1.4	135	0.20	1.4	35	0.16	1.1	–	–	–
	T8430	0.8	165	0.20	1.4	90	0.18	1.4	135	0.20	1.4	35	0.16	1.1	–	–	–
	T9310	0.8	245	0.20	1.4	–	–	–	230	0.20	1.4	–	–	–	–	–	–
	T9315	0.8	220	0.20	1.4	–	–	–	205	0.20	1.4	–	–	–	–	–	–
	T9325	0.8	200	0.20	1.4	120	0.18	1.4	190	0.20	1.4	45	0.16	1.1	–	–	–
VNMG 160412E-FM	T7325	1.2	165	0.22	1.4	125	0.20	1.4	–	–	–	50	0.18	1.1	–	–	–
	T8330	1.2	150	0.22	1.4	90	0.20	1.4	140	0.22	1.4	35	0.18	1.1	–	–	–
	T8430	1.2	165	0.22	1.4	90	0.20	1.4	135	0.22	1.4	35	0.18	1.1	–	–	–
	T9315	1.2	225	0.22	1.4	–	–	–	210	0.22	1.4	–	–	–	–	–	–
	T9325	1.2	200	0.22	1.4	120	0.20	1.4	190	0.22	1.4	45	0.18	1.1	–	–	–

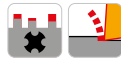
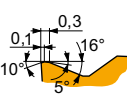

M geometri, finiştan yarı kaba işlemeye kadar ve darbesizden darbeleri kesmeye kadar uygun.

VNMG 160404E-M	T5315	0.4	180	0.20	1.2	–	–	–	170	0.20	1.2	–	–	–	35	0.15	1.0
	T9315	0.4	170	0.20	1.2	–	–	–	160	0.20	1.2	–	–	–	30	0.15	1.0
	T9325	0.4	155	0.20	1.2	–	–	–	145	0.20	1.2	–	–	–	–	–	–
	T9335	0.4	130	0.20	1.2	–	–	–	–	–	–	–	–	–	–	–	–
VNMG 160408E-M	T5305	0.8	205	0.30	1.4	–	–	–	190	0.30	1.4	–	–	–	40	0.15	1.0
	T5315	0.8	185	0.30	1.4	–	–	–	175	0.30	1.4	–	–	–	35	0.15	1.0
	T9310	0.8	185	0.30	1.4	–	–	–	175	0.30	1.4	–	–	–	35	0.15	1.0
	T9315	0.8	170	0.30	1.4	–	–	–	160	0.30	1.4	–	–	–	30	0.15	1.0
	T9325	0.8	150	0.30	1.4	–	–	–	140	0.30	1.4	–	–	–	–	–	–
	T9335	0.8	130	0.30	1.4	–	–	–	–	–	–	–	–	–	–	–	–
VNMG 160412E-M	T9325	1.2	140	0.40	1.4	–	–	–	130	0.40	1.4	–	–	–	–	–	–



Kesme hızı (vc), ilerleme (f) ve kesme derinliği (ap) için uygunluk ve başlangıç değerleri. Daha ileri hesaplamalar için İşleme Hesaplayıcısı uygulamasına başvurun.

Product	RE (mm)	P			M			K			N			S			H		
		vc (m/min)	f (mm/rev)	ap (mm)	vc (m/min)	f (mm/rev)	ap (mm)	vc (m/min)	f (mm/rev)	ap (mm)	vc (m/min)	f (mm/rev)	ap (mm)	vc (m/min)	f (mm/rev)	ap (mm)	vc (m/min)	f (mm/rev)	ap (mm)

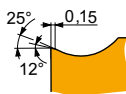

NF geometri, ince finişten orta kabaya kadar işlemek için çok pozitif tasarım, darbesiz kesim için uygun.

VNMG 160404E-NF	T6310	0.4	140	0.12	1.2	100	0.11	1.2	110	0.12	1.2	420	0.14	1.2	40	0.11	1.0	-	-	-
	T7325	0.4	140	0.18	1.2	105	0.16	1.2	-	-	-	-	-	-	45	0.16	1.0	-	-	-
	T7335	0.4	140	0.18	1.2	105	0.16	1.2	-	-	-	-	-	-	45	0.16	1.0	-	-	-
	T8315	0.4	150	0.12	1.2	90	0.11	1.2	140	0.12	1.2	450	0.14	1.2	35	0.11	1.0	-	-	-
	T8330	0.4	140	0.12	1.2	80	0.11	1.2	130	0.12	1.2	420	0.14	1.2	35	0.11	1.0	-	-	-
	T8430	0.4	175	0.12	1.2	95	0.11	1.2	140	0.12	1.2	480	0.14	1.2	35	0.11	1.0	-	-	-
	T9315	0.4	235	0.12	1.2	-	-	-	220	0.12	1.2	-	-	-	-	-	-	-	-	-
	T9325	0.4	180	0.18	1.2	105	0.16	1.2	170	0.18	1.2	-	-	-	40	0.16	1.0	-	-	-
	VNMG 160408E-NF	T6310	0.8	145	0.17	1.4	100	0.15	1.4	115	0.17	1.4	435	0.20	1.4	40	0.14	1.1	-	-
T7325		0.8	165	0.18	1.4	125	0.16	1.4	-	-	-	-	-	50	0.16	1.1	-	-	-	
T7335		0.8	160	0.18	1.4	120	0.16	1.4	-	-	-	-	-	50	0.16	1.1	-	-	-	
T8315		0.8	160	0.17	1.4	95	0.15	1.4	150	0.17	1.4	480	0.20	1.4	40	0.14	1.1	-	-	-
T8330		0.8	150	0.17	1.4	90	0.15	1.4	140	0.17	1.4	450	0.20	1.4	35	0.14	1.1	-	-	-
T8430		0.8	175	0.17	1.4	95	0.15	1.4	140	0.17	1.4	480	0.20	1.4	35	0.14	1.1	-	-	-
T9315		0.8	240	0.17	1.4	-	-	-	225	0.17	1.4	-	-	-	-	-	-	-	-	-
T9325		0.8	210	0.18	1.4	125	0.16	1.4	195	0.18	1.4	-	-	-	45	0.16	1.1	-	-	-

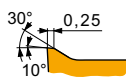

NM geometri, ince finiş, orta ve kaba işlemek için çok pozitif tasarım, darbesiz kesim için uygun.

VNMG 160404E-NM	T7325	0.4	145	0.20	1.2	110	0.18	1.2	-	-	-	-	-	45	0.20	1.0	-	-	-	
	T7335	0.4	140	0.20	1.2	105	0.18	1.2	-	-	-	-	-	45	0.20	1.0	-	-	-	
	T8315	0.4	135	0.20	1.2	80	0.18	1.2	-	-	-	405	0.24	1.2	30	0.20	1.0	-	-	-
	T8330	0.4	125	0.20	1.2	75	0.18	1.2	-	-	-	375	0.24	1.2	30	0.20	1.0	-	-	-
	T8430	0.4	145	0.20	1.2	80	0.18	1.2	-	-	-	405	0.24	1.2	30	0.20	1.0	-	-	-
	T9325	0.4	180	0.20	1.2	105	0.18	1.2	-	-	-	-	-	-	40	0.20	1.0	-	-	-
VNMG 160408E-NM	T7325	0.8	160	0.25	1.4	120	0.23	1.4	-	-	-	-	-	50	0.20	1.1	-	-	-	
	T7335	0.8	155	0.25	1.4	120	0.23	1.4	-	-	-	-	-	50	0.20	1.1	-	-	-	
	T8315	0.8	145	0.25	1.4	85	0.23	1.4	-	-	-	435	0.30	1.4	35	0.20	1.1	-	-	-
	T8330	0.8	140	0.25	1.4	80	0.23	1.4	-	-	-	420	0.30	1.4	35	0.20	1.1	-	-	-
	T8430	0.8	155	0.25	1.4	85	0.23	1.4	-	-	-	435	0.30	1.4	30	0.20	1.1	-	-	-
	T9325	0.8	190	0.25	1.4	110	0.23	1.4	-	-	-	-	-	-	40	0.20	1.1	-	-	-

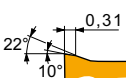

NMR geometri, ortadan kabaya kadar işlemek için pozitif tasarım, darbesiz kesim için uygun.

VNMG 160404E-NMR	T7325	0.4	125	0.20	1.2	95	0.18	1.2	-	-	-	-	-	40	0.18	1.0	-	-	-
	T7335	0.4	120	0.20	1.2	90	0.18	1.2	-	-	-	-	-	35	0.18	1.0	-	-	-
	T9325	0.4	155	0.20	1.2	90	0.18	1.2	-	-	-	-	-	30	0.18	1.0	-	-	-
VNMG 160408E-NMR	T7325	0.8	130	0.30	1.4	100	0.27	1.4	-	-	-	-	-	40	0.24	1.1	-	-	-
	T7335	0.8	125	0.30	1.4	95	0.27	1.4	-	-	-	-	-	40	0.24	1.1	-	-	-
	T8430	0.8	125	0.30	1.4	65	0.27	1.4	-	-	-	-	-	25	0.24	1.1	-	-	-
	T9315	0.8	170	0.30	1.4	-	-	-	-	-	-	-	-	-	-	-	-	-	-
	T9325	0.8	150	0.30	1.4	90	0.27	1.4	-	-	-	-	-	30	0.24	1.1	-	-	-
VNMG 160412E-NMR	T7325	1.2	140	0.30	1.4	105	0.27	1.4	-	-	-	-	-	45	0.24	1.1	-	-	-
	T8330	1.2	120	0.30	1.4	70	0.27	1.4	-	-	-	-	-	30	0.24	1.1	-	-	-
	T8430	1.2	130	0.30	1.4	70	0.27	1.4	-	-	-	-	-	25	0.24	1.1	-	-	-
	T9325	1.2	160	0.30	1.4	95	0.27	1.4	-	-	-	-	-	35	0.24	1.1	-	-	-



Kesme hızı (vc), ilerleme (f) ve kesme derinliği (ap) için uygunluk ve başlangıç değerleri. Daha ileri hesaplamalar için İşleme Hesaplayıcısı uygulamasına başvurun.

Product	RE (mm)	P			M			K			N			S			H		
		vc (m/min)	f (mm/rev)	ap (mm)	vc (m/min)	f (mm/rev)	ap (mm)	vc (m/min)	f (mm/rev)	ap (mm)	vc (m/min)	f (mm/rev)	ap (mm)	vc (m/min)	f (mm/rev)	ap (mm)	vc (m/min)	f (mm/rev)	ap (mm)

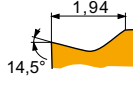

SF geometri, ince finiş ve ince cidar işlemek için pozitif tasarım, darbesiz kesim için uygun.

VNMG 160404E-SF	T6310	0.4	■	135	0.12	1.2	■	95	0.11	1.2	■	105	0.12	1.2	■	405	0.14	1.2	■	40	0.11	1.0	■	25	0.15	1.0
	T7325	0.4	■	140	0.17	1.2	■	105	0.15	1.2	■	—	—	—	■	—	—	—	■	45	0.15	1.0	■	—	—	—
	T8315	0.4	■	140	0.12	1.2	■	80	0.11	1.2	■	130	0.12	1.2	■	420	0.14	1.2	■	35	0.11	1.0	■	25	0.15	1.0
	T8330	0.4	■	135	0.12	1.2	■	80	0.11	1.2	■	125	0.12	1.2	■	405	0.14	1.2	■	30	0.11	1.0	■	25	0.15	1.0
	T8430	0.4	■	165	0.12	1.2	■	90	0.11	1.2	■	135	0.12	1.2	■	450	0.14	1.2	■	35	0.11	1.0	■	25	0.15	1.0
	T9315	0.4	■	225	0.12	1.2	■	—	—	—	■	210	0.12	1.2	■	—	—	—	■	—	—	—	■	45	0.15	1.0
	T9325	0.4	■	175	0.17	1.2	■	105	0.15	1.2	■	165	0.17	1.2	■	—	—	—	■	35	0.15	1.0	■	—	—	—
VNMG 160408E-SF	T6310	0.8	■	140	0.17	1.4	■	100	0.15	1.4	■	110	0.17	1.4	■	420	0.20	1.4	■	40	0.14	1.1	■	25	0.15	1.0
	T8315	0.8	■	150	0.17	1.4	■	90	0.15	1.4	■	140	0.17	1.4	■	450	0.20	1.4	■	35	0.14	1.1	■	30	0.15	1.0
	T8330	0.8	■	145	0.17	1.4	■	85	0.15	1.4	■	135	0.17	1.4	■	435	0.20	1.4	■	35	0.14	1.1	■	25	0.15	1.0
	T8430	0.8	■	165	0.17	1.4	■	90	0.15	1.4	■	135	0.17	1.4	■	450	0.20	1.4	■	35	0.14	1.1	■	25	0.15	1.0
	T9315	0.8	■	230	0.17	1.4	■	—	—	—	■	215	0.17	1.4	■	—	—	—	■	—	—	—	■	45	0.15	1.0
	T9325	0.8	■	205	0.17	1.4	■	120	0.15	1.4	■	190	0.17	1.4	■	—	—	—	■	45	0.15	1.1	■	—	—	—
VNMG 160412E-SF	T6310	1.2	■	145	0.20	1.4	■	100	0.18	1.4	■	115	0.20	1.4	■	435	0.24	1.4	■	40	0.16	1.1	■	25	0.15	1.0
	T7325	1.2	■	165	0.20	1.4	■	125	0.18	1.4	■	—	—	—	■	—	—	—	■	50	0.16	1.1	■	—	—	—

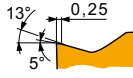

SM geometri, orta işleme için pozitif tasarım, darbesizden darbeleri kesime kadar uygun.

VNMG 160404E-SM	T6310	0.4	■	120	0.18	1.2	■	85	0.16	1.2	■	95	0.18	1.2	■	360	0.22	1.2	■	35	0.16	1.0	■	20	0.15	1.0
	T7325	0.4	■	135	0.18	1.2	■	105	0.16	1.2	■	—	—	—	■	—	—	—	■	40	0.16	1.0	■	—	—	—
	T7335	0.4	■	135	0.18	1.2	■	105	0.16	1.2	■	—	—	—	■	—	—	—	■	40	0.16	1.0	■	—	—	—
	T8330	0.4	■	120	0.18	1.2	■	70	0.16	1.2	■	110	0.18	1.2	■	360	0.22	1.2	■	30	0.16	1.0	■	20	0.15	1.0
	T8430	0.4	■	135	0.18	1.2	■	75	0.16	1.2	■	110	0.18	1.2	■	375	0.22	1.2	■	25	0.16	1.0	■	20	0.15	1.0
	T9315	0.4	■	190	0.18	1.2	■	—	—	—	■	180	0.18	1.2	■	—	—	—	■	—	—	—	■	35	0.15	1.0
	T9325	0.4	■	170	0.18	1.2	■	100	0.16	1.2	■	160	0.18	1.2	■	—	—	—	■	35	0.16	1.0	■	—	—	—
VNMG 160408E-SM	T6310	0.8	■	125	0.25	1.4	■	90	0.23	1.4	■	100	0.25	1.4	■	375	0.30	1.4	■	35	0.20	1.1	■	25	0.15	1.0
	T7325	0.8	■	145	0.25	1.4	■	110	0.23	1.4	■	—	—	—	■	—	—	—	■	45	0.20	1.1	■	—	—	—
	T8330	0.8	■	125	0.25	1.4	■	75	0.23	1.4	■	115	0.25	1.4	■	375	0.30	1.4	■	30	0.20	1.1	■	25	0.15	1.0
	T8430	0.8	■	140	0.25	1.4	■	75	0.23	1.4	■	115	0.25	1.4	■	390	0.30	1.4	■	30	0.20	1.1	■	20	0.15	1.0
	T9315	0.8	■	195	0.25	1.4	■	—	—	—	■	185	0.25	1.4	■	—	—	—	■	—	—	—	■	35	0.15	1.0
	T9325	0.8	■	170	0.25	1.4	■	100	0.23	1.4	■	160	0.25	1.4	■	—	—	—	■	35	0.20	1.1	■	—	—	—
VNMG 160412E-SM	T6310	1.2	■	125	0.30	1.4	■	90	0.27	1.4	■	100	0.30	1.4	■	375	0.36	1.4	■	35	0.24	1.1	■	25	0.15	1.0



VNGA CER

	IC	D1	L	S
	(mm)	(mm)	(mm)	(mm)
1604	9.525	3.81	16.60	4.76

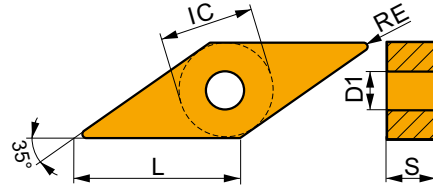

Kesme hızı (vc), ilerleme (f) ve kesme derinliği (ap) için uygunluk ve başlangıç değerleri. Daha ileri hesaplamalar için İşleme Hesaplayıcısı uygulamasına başvurun.

Product	RE	P			M			K			N			S			H		
		vc	f	ap	vc	f	ap	vc	f	ap	vc	f	ap	vc	f	ap	vc	f	ap
	(mm)	(m/min)	(mm/rev)	(mm)	(m/min)	(mm/rev)	(mm)	(m/min)	(mm/rev)	(mm)	(m/min)	(mm/rev)	(mm)	(m/min)	(mm/rev)	(mm)	(m/min)	(mm/rev)	(mm)
VNGA 160404 T01020	TC100	0.4	-	-	-	-	-	425	0.10	1.0	-	-	-	-	-	-	-	-	-
VNGA 160408 T01020	TC100	0.8	-	-	-	-	-	395	0.20	1.0	-	-	-	-	-	-	-	-	-

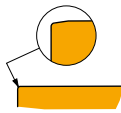

Yüksek hızlı işleme ve darbesiz kesme için.

VNGA 160404 T01020	TC100	0.4	-	-	-	-	-	425	0.10	1.0	-	-	-	-	-	-	-	-	-
VNGA 160408 T01020	TC100	0.8	-	-	-	-	-	395	0.20	1.0	-	-	-	-	-	-	-	-	-

VNGA CBN

	IC	D1	L	S
	(mm)	(mm)	(mm)	(mm)
1604	9.525	3.81	16.00	4.76

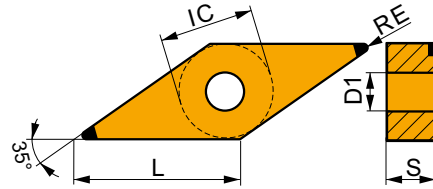

Kesme hızı (vc), ilerleme (f) ve kesme derinliği (ap) için uygunluk ve başlangıç değerleri. Daha ileri hesaplamalar için İşleme Hesaplayıcısı uygulamasına başvurun.

Product	RE	P			M			K			N			S			H		
		vc	f	ap	vc	f	ap	vc	f	ap	vc	f	ap	vc	f	ap	vc	f	ap
	(mm)	(m/min)	(mm/rev)	(mm)	(m/min)	(mm/rev)	(mm)	(m/min)	(mm/rev)	(mm)	(m/min)	(mm/rev)	(mm)	(m/min)	(mm/rev)	(mm)	(m/min)	(mm/rev)	(mm)
VNGA 160404S01020B	TB310	0.4	-	-	-	-	-	360	0.10	0.4	-	-	-	95	0.07	0.3	75	0.15	1.0
VNGA 160408S01020B	TB310	0.8	-	-	-	-	-	370	0.15	0.6	-	-	-	95	0.11	0.5	75	0.15	1.0

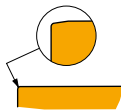

Finiş işleme ve darbesiz kesme için.

VNGA 160404S01020B	TB310	0.4	-	-	-	-	-	360	0.10	0.4	-	-	-	95	0.07	0.3	75	0.15	1.0
VNGA 160408S01020B	TB310	0.8	-	-	-	-	-	370	0.15	0.6	-	-	-	95	0.11	0.5	75	0.15	1.0



DVJN(RL) EXT

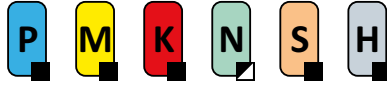

PRAMET

D

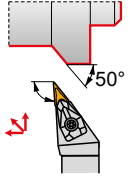

VN.. Uç için Çift Sıkmalı 93° Dış Kateri

Çift sıkmalı 93° Sağ/Sol dış kater. Negatif VN.. 16 uçlarla çap, kopya, konik ve pah tornalama için uygundur. 20x20 - 32x32mm shaft ölçüleri. Gövde uzun takım ömrü için işlem görmüştür.

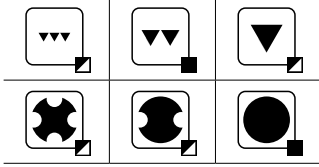
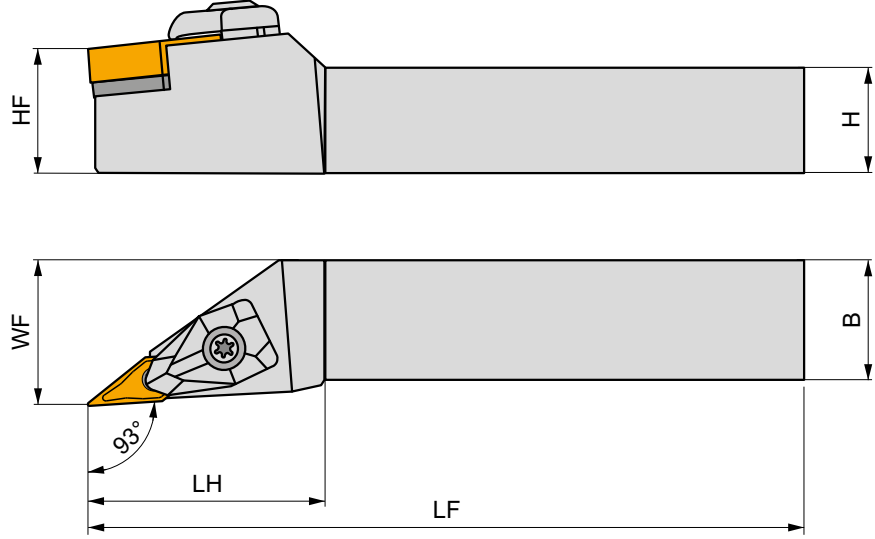

Product	H	B	HF	WF	LF	LH	LAMS	GAMO	kg		
	(mm)	(mm)	(mm)	(mm)	(mm)	(mm)	(°)	(°)			
R DVJNR 2020 K 16	20	20	20	25	125	46.4	-13	-4	0.43	GI048	DV16
DVJNR 2525 M 16	25	25	25	32	150	46.4	-13	-4	0.75	GI048	DV16
DVJNR 3225 P 16	32	25	32	32	170	46.4	-13	-4	1.05	GI048	DV16
L DVJNL 2020 K 16	20	20	20	25	125	46.4	-13	-4	0.43	GI048	DV16
DVJNL 2525 M 16	25	25	25	32	150	46.4	-13	-4	0.75	GI048	DV16
DVJNL 3225 P 16	32	25	32	32	170	46.4	-13	-4	1.06	GI048	DV16



GI048



VN.. 1604..



DV16



DCS 16V



3.0



DVS 269-01



US 2009-T15P



FLAGT15P/3,5



DVPN(RL) EXT

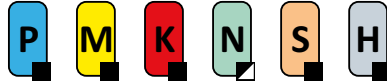

PRAMET

D



VN.. Uç için Çift Sıkmalı 117.5° Dış Kateri

Çift sıkmalı 117.5° Sağ/Sol dış kater. Negatif VN.. 16 uçlarla çap, kopya, konik ve pah tornalama için uygundur. 25x25 - 32x25mm şaft ölçüleri. Gövde uzun takım ömrü için işlem görmüştür.

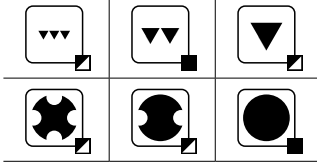
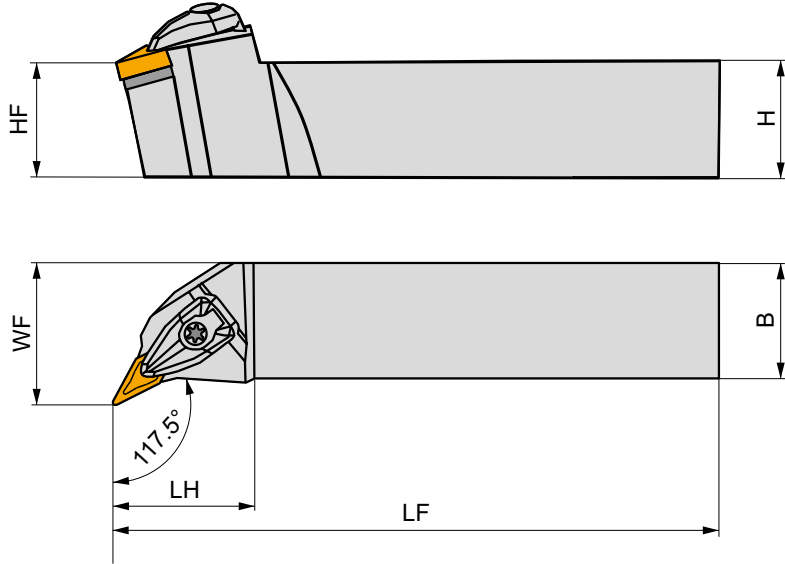
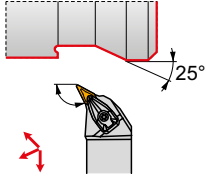

Product	H	B	HF	WF	LF	LH	LAMS	GAMO	kg	GI048	DV16
	(mm)	(mm)	(mm)	(mm)	(mm)	(mm)	(°)	(°)			
R DVPNR 2525 M 16	25	25	25	32	150	39.2	-13	-4	0.75	GI048	DV16
DVPNR 3225 P 16	32	25	32	32	170	39.2	-13	-4	1.06	GI048	DV16
L DVPNL 2525 M 16	25	25	25	32	150	39.2	-13	-4	0.74	GI048	DV16
DVPNL 3225 P 16	32	25	32	32	170	39.2	-13	-4	1.06	GI048	DV16



GI048



VN.. 1604..



DV16



DCS 16V



3.0



DVS 269-01



US 2009-T15P



FLAG T15P/3,5



MVJN(RL) EXT

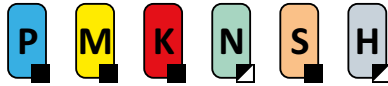

PRAMET

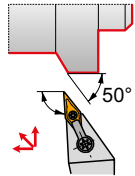

VN.. Uç için Pabuçlu 93° Açılı Dış Kater

Pabuçlu, 93° açılı Sağ/Sol dış kater. Negatif VN.. 16 uçlarla çap, 50°'ye kadar kopya, konik ve pah tormalamak için uygundur. 20x20'den 32x25mm'ye kadar mevcuttur. Gövde uzun takım ömrü için işlem görmüştür.

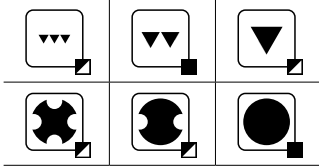
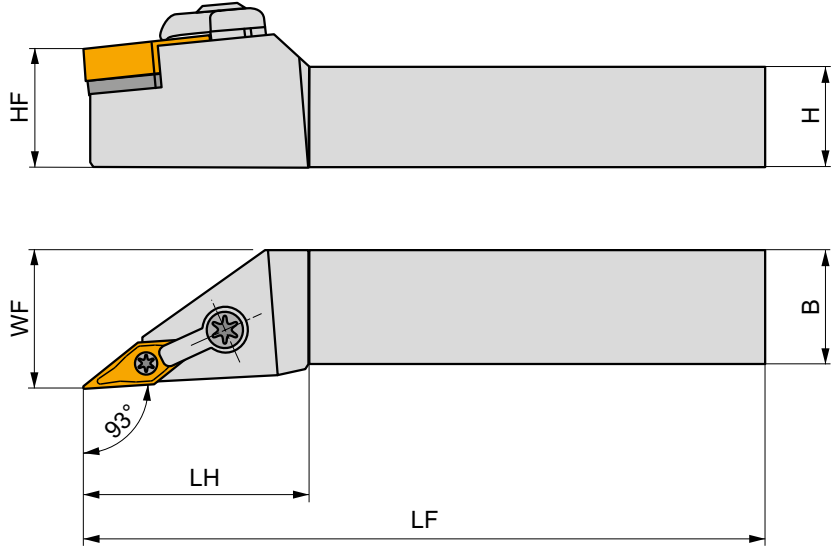

Product	H	B	HF	WF	LF	LH	LAMS	GAMO	kg		
	(mm)	(mm)	(mm)	(mm)	(mm)	(mm)	(°)	(°)			
R MVJNR 2020 K 16-A	20	20	20	25	125	41	-4.5	-13.5	0.40	GI048	MV2
MVJNR 2525 M 16-A	25	25	25	32	150	41	-4.5	-13.5	0.70	GI048	MV2
MVJNR 3225 P 16-A	32	25	32	32	170	41	-4.5	-13.5	0.98	GI048	MV2
L MVJNL 2020 K 16-A	20	20	20	25	125	41	-4.5	-13.5	0.40	GI048	MV2
MVJNL 2525 M 16-A	25	25	25	32	150	41	-4.5	-13.5	0.70	GI048	MV2
MVJNL 3225 P 16-A	32	25	32	32	170	41	-4.5	-13.5	0.96	GI048	MV2



GI048



VN.. 1604..



MV2



UPC22



MVN 160316



UP 0909-T09P



2.0



PS 6026-T09P



2.0

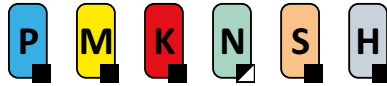

FLAG T09P

NEW
C.-DVJN(RL) EXT

PRAMET
D

VN.. Uç için Çift Sıklımlı, 93° Açılı Hızlı Değişirme Dış Takımı

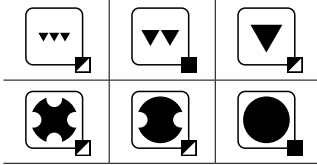
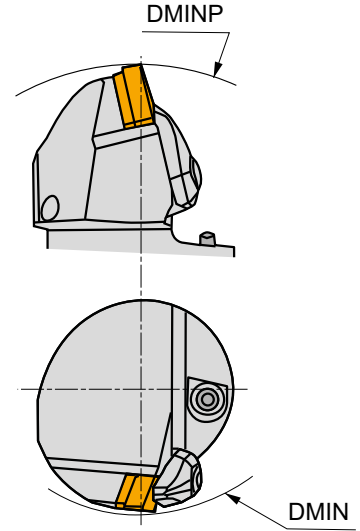
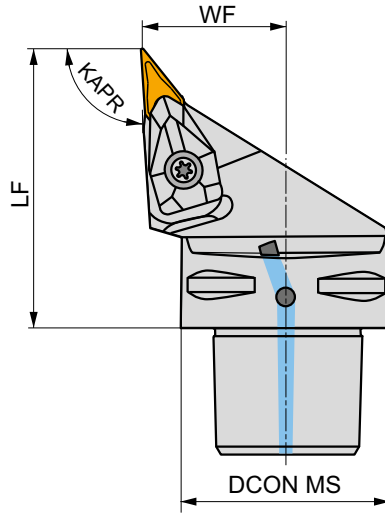
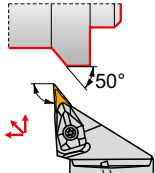
Çift sıklımlı, 93° açılı, içten su vermeli Sağ/Sol dış kater. Negatif VN.. 16 uçlarla çap, alın, konik ve pah tornalamak için uygundur. C4 - C6 şaftlı mevcuttur. Tutucu uzun takım ömrü için işlem görmüştür.



Product	DCON MS	DMIN	DMINP	WF	LF	KAPR	LAMS	GAMO	✓	kg	GI048	C-DV16-1
	(mm)	(mm)	(mm)	(mm)	(mm)	(°)	(°)	(°)				
R C4-DVJNR-27062-16	40	60	152	27	62	93	-13	-4	✓	0.45	GI048	C-DV16-1
C5-DVJNR-35065-16	50	65	170	35	65	93	-13	-4	✓	0.47	GI048	C-DV16-2
C6-DVJNR-45065-16	63	81	190	45	65	93	-13	-4	✓	1.13	GI048	C-DV16-2
L C4-DVJNL-27062-16	40	60	152	27	62	93	-13	-4	✓	0.45	GI048	C-DV16-1
C5-DVJNL-35065-16	50	65	170	35	65	93	-13	-4	✓	0.72	GI048	C-DV16-2
C6-DVJNL-45065-16	63	81	190	45	65	93	-13	-4	✓	1.13	GI048	C-DV16-2



GI048



VN.. 1604..



C-DV16-1

DCS 16V

3.0

DVS 269-01

US 2009-T15P

FLAGT15P/3,5

CN 034-01

C-DV16-2

DCS 16V

3.0

DVS 269-01

US 2009-T15P

FLAGT15P/3,5

CN 034-02



DVUN(RL) INT



PRAMET

D



VN.. Uç için Çift Sıkmalı 93° Açılı Delik Kateri

Çift sıkmalı 93° Sağ/Sol içten su vermeli delik kateri. Negatif VN.. 16 uçlarla minimum Ø50mm çap, konik, kopya ve pah tormalama için uygundur. Ø40mm şaft ölçüleri. Gövde uzun takım ömrü için işlem görmüştür.

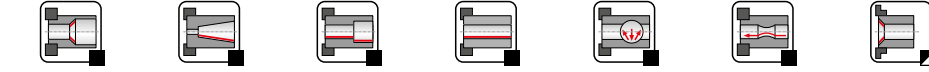
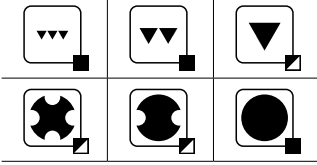
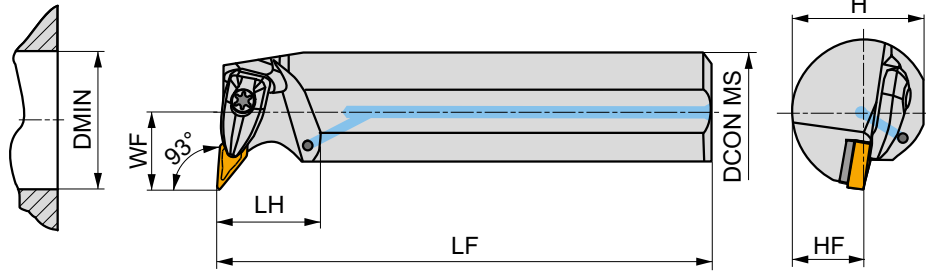
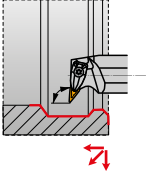

Product	DCON MS (mm)	DMIN (mm)	WF (mm)	H (mm)	HF (mm)	LF (mm)	LH (mm)	LAMS (°)	GAMO (°)		kg		
R A40T-DVUNR 16	40	50	27	37	18,5	300	36	-9	-6	✓	2.59	GI048	DV16
L A40T-DVUNL 16	40	50	27	37	18,5	300	36	-9	-6	✓	2.59	GI048	DV16



GI048



VN.. 1604..



DV16



DCS 16V



3.0



DVS 269-01



US 2009-T15P



FLAG T15P/3,5



WN

06/ 08/ 10/ 13

KARBÜR UÇLAR

WNMA



366

WNMG



366

WNMM



375

CER VE CBN UÇLAR

WNGA CBN



376

DOĞRU BOYUTLA EŞLEŞTİRİN (örnek)

Kesici uç

WNMA 080408

Takım Tutucu

DWLNL 2020 K 08

ISO TORNALAMA - DIŞ

DWLN(RL) EXT

95°

WN..

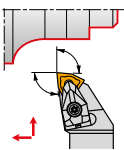
06
08
10
1316x16
40x40

377

366 – 376

MWLN(RL) EXT

95°

WN..

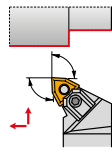

08

25x25
40x40

379

366 – 376

PWLN(RL) EXT

95°

WN..

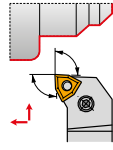
06
0816x16
32x25

380

366 – 376

C.-DWLN(RL) EXT **NEW**

95°

WN..

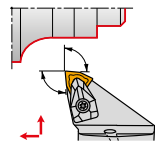
06
08C4
C6

381

366 – 376

ISO TORNALAMA - İÇ

DWLN(RL) INT

95°

WN..

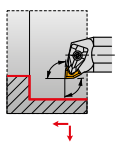
06
0832
63

382

366 – 376

PWLN(RL) INT

95°

WN..

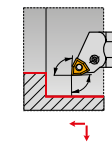
06
0820
80

383

366 – 376

C.-DWLN(RL) INT **NEW**

95°

WN..

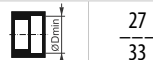
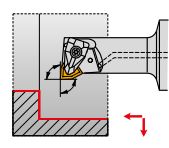
06
0827
33

385

366 – 376



WNMA

	IC	D1	L	S
	(mm)	(mm)	(mm)	(mm)
0804	12.700	5.16	8.70	4.76

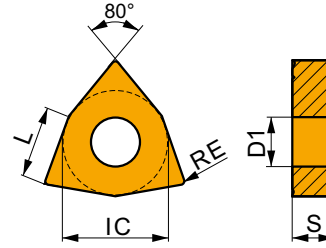

Kesme hızı (vc), ilerleme (f) ve kesme derinliği (ap) için uygunluk ve başlangıç değerleri. Daha ileri hesaplamalar için İşleme Hesaplayıcısı uygulamasına başvurun.

Product	RE	P			M			K			N			S			H		
		vc	f	ap	vc	f	ap	vc	f	ap	vc	f	ap	vc	f	ap	vc	f	ap
	(mm)	(m/min)	(mm/rev)	(mm)	(m/min)	(mm/rev)	(mm)	(m/min)	(mm/rev)	(mm)	(m/min)	(mm/rev)	(mm)	(m/min)	(mm/rev)	(mm)	(m/min)	(mm/rev)	(mm)

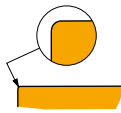

İnce finişten yarı kaba işleme kadar ve darbesizden hafif darbeli kesmeye kadar uygun.

WNMA 080404	T5305	0.4	-	-	-	-	-	-	235	0.10	4.0	-	-	-	-	-	-	50	0.15	1.0
	T5315	0.4	-	-	-	-	-	-	200	0.10	4.0	-	-	-	-	-	-	40	0.15	1.0
WNMA 080408	T5305	0.8	-	-	-	-	-	-	220	0.20	4.0	-	-	-	-	-	-	45	0.15	1.0
	T5315	0.8	-	-	-	-	-	-	190	0.20	4.0	-	-	-	-	-	-	40	0.15	1.0
	T6310	0.8	-	-	-	-	-	-	100	0.20	4.0	-	-	-	-	-	-	25	0.15	1.0
WNMA 080412	T5305	1.2	-	-	-	-	-	-	195	0.30	4.0	-	-	-	-	-	-	40	0.15	1.0
	T5315	1.2	-	-	-	-	-	-	180	0.30	4.0	-	-	-	-	-	-	35	0.15	1.0
	T6310	1.2	-	-	-	-	-	-	95	0.30	4.0	-	-	-	-	-	-	20	0.15	1.0

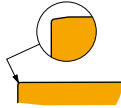

İnce finişten yarı kaba işleme kadar ve darbesizden hafif darbeli kesmeye kadar uygun.

WNMA 080408S	T5305	0.8	-	-	-	-	-	-	220	0.20	4.0	-	-	-	-	-	-	45	0.15	1.0
--------------	-------	-----	---	---	---	---	---	---	-----	------	-----	---	---	---	---	---	---	----	------	-----

WNMG

	IC	D1	L	S
	(mm)	(mm)	(mm)	(mm)
0604	9.525	3.81	6.50	4.76
06T3	9.525	3.81	6.50	3.97
0804	12.700	5.16	8.70	4.76

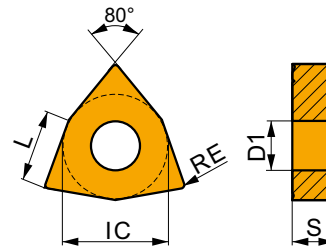

Kesme hızı (vc), ilerleme (f) ve kesme derinliği (ap) için uygunluk ve başlangıç değerleri. Daha ileri hesaplamalar için İşleme Hesaplayıcısı uygulamasına başvurun.

Product	RE	P			M			K			N			S			H		
		vc	f	ap	vc	f	ap	vc	f	ap	vc	f	ap	vc	f	ap	vc	f	ap
	(mm)	(m/min)	(mm/rev)	(mm)	(m/min)	(mm/rev)	(mm)	(m/min)	(mm/rev)	(mm)	(m/min)	(mm/rev)	(mm)	(m/min)	(mm/rev)	(mm)	(m/min)	(mm/rev)	(mm)

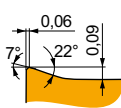

FF geometri, ince-finiş işleme için çok pozitif tasarım, darbesizden hafif darbeli işleme kadar uygun.

WNMG 060402E-FF	T8315	0.2	215	0.10	1.0	125	0.09	1.0	200	0.10	1.0	-	-	-	-	-	-	-	-	-
WNMG 060404E-FF	T8315	0.4	220	0.12	1.0	130	0.11	1.0	205	0.12	1.0	-	-	-	-	-	-	-	-	-



Kesme hızı (vc), ilerleme (f) ve kesme derinliği (ap) için uygunluk ve başlangıç değerleri. Daha ileri hesaplamalar için İşleme Hesaplayıcısı uygulamasına başvurun.

Product	RE (mm)	P			M			K			N			S			H		
		vc (m/min)	f (mm/rev)	ap (mm)	vc (m/min)	f (mm/rev)	ap (mm)	vc (m/min)	f (mm/rev)	ap (mm)	vc (m/min)	f (mm/rev)	ap (mm)	vc (m/min)	f (mm/rev)	ap (mm)	vc (m/min)	f (mm/rev)	ap (mm)

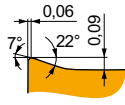

FF geometri, ince-finiş işleme için çok pozitif tasarım, darbesizden hafif darbeleri işlemeye kadar uygun.

WNMG 080404E-FF	T7325	0.4	235	0.12	1.0	180	0.11	1.0	-	-	-	-	-	-	-	-	-	-
	T8315	0.4	220	0.12	1.0	130	0.11	1.0	205	0.12	1.0	-	-	-	-	-	-	-
WNMG 080408E-FF	T7325	0.8	265	0.15	1.0	205	0.14	1.0	-	-	-	-	-	-	-	-	-	-
	T8315	0.8	245	0.15	1.0	145	0.14	1.0	230	0.15	1.0	-	-	-	-	-	-	-

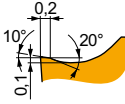

FM pozitif geometri, finişten yarı kaba işlemeye, ve darbesizden hafif darbeleri kesmeye kadar uygun.

WNMG 060404E-FM	T7325	0.4	195	0.20	1.4	150	0.18	1.4	-	-	-	-	-	60	0.16	1.1	-	-	-	
	T8315	0.4	180	0.20	1.4	105	0.18	1.4	170	0.20	1.4	-	-	45	0.14	1.1	-	-	-	
	T8330	0.4	175	0.20	1.4	105	0.18	1.4	165	0.20	1.4	-	-	40	0.14	1.1	-	-	-	
	T8430	0.4	195	0.20	1.4	105	0.18	1.4	160	0.20	1.4	-	-	40	0.14	1.1	-	-	-	
	T9315	0.4	265	0.20	1.4	-	-	-	250	0.20	1.4	-	-	-	-	-	-	-	-	
	T9325	0.4	240	0.20	1.4	140	0.18	1.4	225	0.20	1.4	-	-	50	0.16	1.1	-	-	-	
	TT310	0.4	275	0.20	1.4	165	0.18	1.4	-	-	-	-	-	-	-	-	-	-	-	
	WNMG 060408E-FM	T7325	0.8	235	0.20	1.4	180	0.18	1.4	-	-	-	-	-	75	0.16	1.1	-	-	-
		T8330	0.8	205	0.20	1.4	120	0.18	1.4	190	0.20	1.4	-	-	50	0.14	1.1	-	-	-
		T8430	0.8	235	0.20	1.4	125	0.18	1.4	190	0.20	1.4	-	-	50	0.14	1.1	-	-	-
T9315		0.8	315	0.20	1.4	-	-	-	295	0.20	1.4	-	-	-	-	-	-	-	-	
WNMG 060412E-FM	T9325	0.8	285	0.20	1.4	170	0.18	1.4	270	0.20	1.4	-	-	60	0.16	1.1	-	-	-	
	T9315	1.2	300	0.27	1.2	-	-	-	285	0.27	1.2	-	-	-	-	-	-	-	-	
WNMG 06T304E-FM	T7325	0.4	195	0.20	1.4	150	0.18	1.4	-	-	-	-	-	60	0.16	1.1	-	-	-	
	T8330	0.4	175	0.20	1.4	105	0.18	1.4	165	0.20	1.4	-	-	40	0.14	1.1	-	-	-	
	T8430	0.4	195	0.20	1.4	105	0.18	1.4	160	0.20	1.4	-	-	40	0.14	1.1	-	-	-	
	T9325	0.4	240	0.20	1.4	140	0.18	1.4	225	0.20	1.4	-	-	50	0.16	1.1	-	-	-	
WNMG 06T308E-FM	T8330	0.8	205	0.20	1.4	120	0.18	1.4	190	0.20	1.4	-	-	50	0.14	1.1	-	-	-	
	T8430	0.8	235	0.20	1.4	125	0.18	1.4	190	0.20	1.4	-	-	50	0.14	1.1	-	-	-	
	T9325	0.8	285	0.20	1.4	170	0.18	1.4	270	0.20	1.4	-	-	60	0.16	1.1	-	-	-	
WNMG 080404E-FM	T7325	0.4	190	0.20	1.9	145	0.18	1.9	-	-	-	-	-	60	0.16	1.5	-	-	-	
	T7335	0.4	180	0.20	1.9	140	0.18	1.9	-	-	-	-	-	55	0.16	1.5	-	-	-	
	T8315	0.4	180	0.20	1.9	105	0.18	1.9	170	0.20	1.9	-	-	45	0.14	1.5	-	-	-	
	T8330	0.4	165	0.20	1.9	95	0.18	1.9	155	0.20	1.9	-	-	40	0.14	1.5	-	-	-	
	T8430	0.4	190	0.20	1.9	105	0.18	1.9	155	0.20	1.9	-	-	40	0.14	1.5	-	-	-	
	T9310	0.4	285	0.20	1.9	-	-	-	270	0.20	1.9	-	-	-	-	-	-	-	-	
	T9315	0.4	270	0.20	1.2	-	-	-	255	0.20	1.2	-	-	-	-	-	-	-	-	
WNMG 080408E-FM	T9325	0.4	245	0.20	1.2	145	0.18	1.2	230	0.20	1.2	-	-	55	0.16	1.0	-	-	-	
	T7325	0.8	225	0.20	1.9	175	0.18	1.9	-	-	-	-	-	70	0.16	1.5	-	-	-	
	T7335	0.8	215	0.20	1.9	165	0.18	1.9	-	-	-	-	-	65	0.16	1.5	-	-	-	
	T8315	0.8	210	0.20	1.9	125	0.18	1.9	195	0.20	1.9	-	-	50	0.16	1.5	-	-	-	
	T8330	0.8	195	0.20	1.9	115	0.18	1.9	185	0.20	1.9	-	-	45	0.16	1.5	-	-	-	
	T8430	0.8	225	0.20	1.9	120	0.18	1.9	185	0.20	1.9	-	-	45	0.16	1.5	-	-	-	
	T9310	0.8	335	0.20	1.9	-	-	-	315	0.20	1.9	-	-	-	-	-	-	-	-	
WNMG 080412E-FM	T9315	0.8	310	0.20	1.9	-	-	-	290	0.20	1.9	-	-	-	-	-	-	-	-	
	T9325	0.8	280	0.20	1.9	165	0.18	1.9	265	0.20	1.9	-	-	60	0.16	1.5	-	-	-	
	T7325	1.2	220	0.27	1.9	170	0.24	1.9	-	-	-	-	-	70	0.19	1.5	-	-	-	
	T7335	1.2	205	0.27	1.9	155	0.24	1.9	-	-	-	-	-	65	0.19	1.5	-	-	-	
	T8330	1.2	190	0.27	1.9	110	0.24	1.9	180	0.27	1.9	-	-	45	0.19	1.5	-	-	-	
	T8430	1.2	210	0.27	1.9	115	0.24	1.9	175	0.27	1.9	-	-	45	0.19	1.5	-	-	-	
	T9310	1.2	310	0.27	1.9	-	-	-	290	0.27	1.9	-	-	-	-	-	-	-	-	
WNMG 080412E-FM	T9315	1.2	285	0.27	1.9	-	-	-	270	0.27	1.9	-	-	-	-	-	-	-	-	
	T9325	1.2	255	0.27	1.9	150	0.24	1.9	240	0.27	1.9	-	-	55	0.19	1.5	-	-	-	



Kesme hızı (vc), ilerleme (f) ve kesme derinliği (ap) için uygunluk ve başlangıç değerleri. Daha ileri hesaplamalar için İşleme Hesaplayıcısı uygulamasına başvurun.

Product	RE (mm)	P			M			K			N			S			H		
		vc (m/min)	f (mm/rev)	ap (mm)	vc (m/min)	f (mm/rev)	ap (mm)	vc (m/min)	f (mm/rev)	ap (mm)	vc (m/min)	f (mm/rev)	ap (mm)	vc (m/min)	f (mm/rev)	ap (mm)	vc (m/min)	f (mm/rev)	ap (mm)

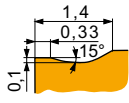

KR geometri, yarı kabadan kaba işleme kadar, darbesizden darbeli kesime kadar uygun.

WNMG 080408E-KR	T5305	0.8	255	0.35	3.5	–	–	–	240	0.35	3.5	–	–	–	–	–	–	–	50	0.15	1.0
	T5315	0.8	230	0.35	3.5	–	–	–	215	0.35	3.5	–	–	–	–	–	–	–	45	0.15	1.0
WNMG 080412E-KR	T5305	1.2	260	0.40	3.5	–	–	–	245	0.40	3.5	–	–	–	–	–	–	–	50	0.15	1.0
	T5315	1.2	235	0.40	3.5	–	–	–	220	0.40	3.5	–	–	–	–	–	–	–	45	0.15	1.0

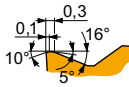

M geometri, finişten yarı kaba işleme kadar ve darbesizden darbeli kesime kadar uygun.

WNMG 060404E-M	T5315	0.4	250	0.20	1.8	–	–	–	235	0.20	1.8	–	–	–	–	–	–	–	50	0.15	1.0
	T9315	0.4	240	0.20	1.8	–	–	–	225	0.20	1.8	–	–	–	–	–	–	–	45	0.15	1.0
	T9325	0.4	215	0.20	1.8	–	–	–	200	0.20	1.8	–	–	–	–	–	–	–	–	–	–
	T9335	0.4	180	0.20	1.8	–	–	–	–	–	–	–	–	–	–	–	–	–	–	–	–
WNMG 060408E-M	T5315	0.8	255	0.32	1.8	–	–	–	240	0.32	1.8	–	–	–	–	–	–	–	50	0.15	1.0
	T9310	0.8	250	0.32	1.8	–	–	–	235	0.32	1.8	–	–	–	–	–	–	–	50	0.15	1.0
	T9315	0.8	230	0.32	1.8	–	–	–	215	0.32	1.8	–	–	–	–	–	–	–	45	0.15	1.0
	T9325	0.8	205	0.32	1.8	–	–	–	190	0.32	1.8	–	–	–	–	–	–	–	–	–	–
	T9335	0.8	180	0.32	1.8	–	–	–	–	–	–	–	–	–	–	–	–	–	–	–	–
WNMG 080404E-M	T5315	0.4	260	0.20	1.2	–	–	–	245	0.20	1.2	–	–	–	–	–	–	–	50	0.15	1.0
	T9315	0.4	235	0.20	2.1	–	–	–	220	0.20	2.1	–	–	–	–	–	–	–	45	0.15	1.0
	T9325	0.4	210	0.20	2.1	–	–	–	195	0.20	2.1	–	–	–	–	–	–	–	–	–	–
	T9335	0.4	180	0.20	2.1	–	–	–	–	–	–	–	–	–	–	–	–	–	–	–	–
WNMG 080408E-M	T5305	0.8	280	0.32	2.1	–	–	–	265	0.32	2.1	–	–	–	–	–	–	–	55	0.15	1.0
	T5315	0.8	250	0.32	2.1	–	–	–	235	0.32	2.1	–	–	–	–	–	–	–	50	0.15	1.0
	T8330	0.8	155	0.32	2.1	–	–	–	145	0.32	2.1	–	–	–	–	–	–	–	30	0.15	1.0
	T8430	0.8	170	0.32	2.1	–	–	–	135	0.32	2.1	–	–	–	–	–	–	–	25	0.15	1.0
	T9310	0.8	245	0.32	2.1	–	–	–	230	0.32	2.1	–	–	–	–	–	–	–	45	0.15	1.0
	T9315	0.8	225	0.32	2.1	–	–	–	210	0.32	2.1	–	–	–	–	–	–	–	45	0.15	1.0
	T9325	0.8	200	0.32	2.1	–	–	–	190	0.32	2.1	–	–	–	–	–	–	–	–	–	–
	T9335	0.8	180	0.32	2.1	–	–	–	–	–	–	–	–	–	–	–	–	–	–	–	–
WNMG 080412E-M	T5305	1.2	275	0.40	2.1	–	–	–	260	0.40	2.1	–	–	–	–	–	–	–	55	0.15	1.0
	T5315	1.2	245	0.40	2.1	–	–	–	230	0.40	2.1	–	–	–	–	–	–	–	45	0.15	1.0
	T9310	1.2	235	0.40	2.1	–	–	–	220	0.40	2.1	–	–	–	–	–	–	–	45	0.15	1.0
	T9315	1.2	220	0.40	2.1	–	–	–	205	0.40	2.1	–	–	–	–	–	–	–	40	0.15	1.0
	T9325	1.2	195	0.40	2.1	–	–	–	185	0.40	2.1	–	–	–	–	–	–	–	–	–	–
T9335	1.2	170	0.40	2.1	–	–	–	–	–	–	–	–	–	–	–	–	–	–	–	–	

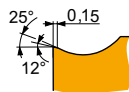

NF geometri, ince finişten orta kabaya kadar işlemek için çok pozitif tasarım, darbesiz kesim için uygun.

WNMG 060404E-NF	T6310	0.4	190	0.17	0.8	135	0.15	0.8	150	0.17	0.8	570	0.20	0.8	55	0.12	0.6	–	–	–	
	T7325	0.4	215	0.18	0.8	165	0.16	0.8	–	–	–	–	–	–	65	0.16	0.6	–	–	–	
	T7335	0.4	210	0.18	0.8	160	0.16	0.8	–	–	–	–	–	–	65	0.16	0.6	–	–	–	
	T8315	0.4	200	0.17	0.8	120	0.15	0.8	190	0.17	0.8	600	0.20	0.8	50	0.12	0.6	–	–	–	
	T8330	0.4	190	0.17	0.8	110	0.15	0.8	180	0.17	0.8	570	0.20	0.8	45	0.12	0.6	–	–	–	
	T8430	0.4	225	0.17	0.8	120	0.15	0.8	185	0.17	0.8	615	0.20	0.8	45	0.12	0.6	–	–	–	
	T9315	0.4	305	0.17	0.8	–	–	–	285	0.17	0.8	–	–	–	–	–	–	–	–	–	–
	T9325	0.4	265	0.18	0.8	155	0.16	0.8	250	0.18	0.8	–	–	–	55	0.16	0.6	–	–	–	
	T9335	0.4	235	0.18	0.8	145	0.16	0.8	220	0.18	0.8	–	–	–	55	0.16	0.6	–	–	–	
WNMG 060408E-NF	T6310	0.8	215	0.19	1.0	150	0.17	1.0	170	0.19	1.0	645	0.23	1.0	60	0.15	0.8	–	–	–	
	T7325	0.8	245	0.19	1.0	190	0.17	1.0	–	–	–	–	–	75	0.15	0.8	–	–	–		
	T8330	0.8	215	0.19	1.0	125	0.17	1.0	200	0.19	1.0	645	0.23	1.0	50	0.15	0.8	–	–	–	
	T8430	0.8	245	0.19	1.0	135	0.17	1.0	200	0.19	1.0	675	0.23	1.0	50	0.15	0.8	–	–	–	
	T9315	0.8	335	0.19	1.0	–	–	–	315	0.19	1.0	–	–	–	–	–	–	–	–	–	
	T9325	0.8	300	0.19	1.0	180	0.17	1.0	285	0.19	1.0	–	–	–	65	0.15	0.8	–	–	–	



Kesme hızı (vc), ilerleme (f) ve kesme derinliği (ap) için uygunluk ve başlangıç değerleri. Daha ileri hesaplamalar için İşleme Hesaplayıcısı uygulamasına başvurun.

Product	RE (mm)	P			M			K			N			S			H		
		vc (m/min)	f (mm/rev)	ap (mm)	vc (m/min)	f (mm/rev)	ap (mm)	vc (m/min)	f (mm/rev)	ap (mm)	vc (m/min)	f (mm/rev)	ap (mm)	vc (m/min)	f (mm/rev)	ap (mm)	vc (m/min)	f (mm/rev)	ap (mm)

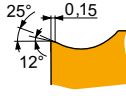

NF geometri, ince fişişten orta kabaya kadar işlemek için çok pozitif tasarım, darbesiz kesim için uygun.

WNMG 080404E-NF	HF7	0.4	-	-	-	95	0.15	1.7	155	0.17	1.7	495	0.20	1.7	-	-	-	-	-	-
	T6310	0.4	180	0.17	1.7	125	0.15	1.7	145	0.17	1.7	540	0.20	1.7	50	0.14	1.4	-	-	-
	T7325	0.4	200	0.18	1.7	155	0.16	1.7	-	-	-	-	-	-	65	0.16	1.4	-	-	-
	T7335	0.4	195	0.18	1.7	150	0.16	1.7	-	-	-	-	-	-	60	0.16	1.4	-	-	-
	T8315	0.4	185	0.17	1.7	110	0.15	1.7	175	0.17	1.7	555	0.20	1.7	45	0.14	1.4	-	-	-
	T8330	0.4	180	0.17	1.7	105	0.15	1.7	170	0.17	1.7	540	0.20	1.7	45	0.14	1.4	-	-	-
	T8430	0.4	200	0.17	1.7	110	0.15	1.7	165	0.17	1.7	555	0.20	1.7	40	0.14	1.4	-	-	-
	T9315	0.4	285	0.17	1.7	-	-	-	270	0.17	1.7	-	-	-	-	-	-	-	-	-
	T9325	0.4	250	0.18	1.7	150	0.16	1.7	235	0.18	1.7	-	-	-	55	0.16	1.4	-	-	-
WNMG 080408E-NF	HF7	0.8	-	-	-	110	0.17	1.7	180	0.19	1.7	570	0.23	1.7	-	-	-	-	-	-
	T6310	0.8	200	0.19	1.7	140	0.17	1.7	160	0.19	1.7	600	0.23	1.7	60	0.15	1.4	-	-	-
	T7325	0.8	235	0.19	1.7	180	0.17	1.7	-	-	-	-	-	75	0.15	1.4	-	-	-	
	T7335	0.8	225	0.19	1.7	175	0.17	1.7	-	-	-	-	-	70	0.15	1.4	-	-	-	
	T8315	0.8	215	0.19	1.7	125	0.17	1.7	200	0.19	1.7	645	0.23	1.7	50	0.15	1.4	-	-	-
	T8330	0.8	200	0.19	1.7	120	0.17	1.7	190	0.19	1.7	600	0.23	1.7	50	0.15	1.4	-	-	-
	T8430	0.8	235	0.19	1.7	125	0.17	1.7	190	0.19	1.7	645	0.23	1.7	50	0.15	1.4	-	-	-
	T9315	0.8	320	0.19	1.7	-	-	-	300	0.19	1.7	-	-	-	-	-	-	-	-	-
	T9325	0.8	285	0.19	1.7	170	0.17	1.7	270	0.19	1.7	-	-	-	60	0.15	1.4	-	-	-
WNMG 080412E-NF	T6310	1.2	185	0.30	2.1	130	0.27	2.1	145	0.30	2.1	555	0.36	2.1	55	0.21	1.7	-	-	-
	T7325	1.2	205	0.30	2.1	155	0.27	2.1	-	-	-	-	-	65	0.21	1.7	-	-	-	
	T8430	1.2	200	0.30	2.1	110	0.27	2.1	165	0.30	2.1	555	0.36	2.1	40	0.21	1.7	-	-	-
	T9315	1.2	275	0.30	2.1	-	-	-	260	0.30	2.1	-	-	-	-	-	-	-	-	-
	T9325	1.2	245	0.30	2.1	145	0.27	2.1	230	0.30	2.1	-	-	-	55	0.21	1.7	-	-	-

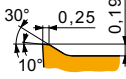

NM geometri, ince fişiş, orta ve kaba işlemek için çok pozitif tasarım, darbesiz kesim için uygun.

WNMG 060404E-NM	T7325	0.4	200	0.20	1.8	155	0.18	1.8	-	-	-	-	-	65	0.16	1.4	-	-	-
	T7335	0.4	195	0.20	1.8	150	0.18	1.8	-	-	-	-	-	60	0.16	1.4	-	-	-
	T8315	0.4	185	0.20	1.8	110	0.18	1.8	-	-	-	555	0.24	1.8	45	0.16	1.4	-	-
	T8330	0.4	175	0.20	1.8	105	0.18	1.8	-	-	-	525	0.24	1.8	40	0.16	1.4	-	-
	T8430	0.4	185	0.25	1.8	100	0.23	1.8	-	-	-	510	0.30	1.8	40	0.20	1.4	-	-
WNMG 060408E-NM	T9325	0.4	245	0.20	1.8	145	0.18	1.8	-	-	-	-	-	55	0.16	1.4	-	-	-
	T7325	0.8	220	0.25	1.8	170	0.23	1.8	-	-	-	-	-	70	0.20	1.4	-	-	-
	T7335	0.8	215	0.25	1.8	165	0.23	1.8	-	-	-	-	-	65	0.20	1.4	-	-	-
	T8315	0.8	205	0.25	1.8	120	0.23	1.8	-	-	-	615	0.30	1.8	50	0.20	1.4	-	-
	T8330	0.8	195	0.25	1.8	115	0.23	1.8	-	-	-	585	0.30	1.8	45	0.20	1.4	-	-
	T8430	0.8	220	0.25	1.8	120	0.23	1.8	-	-	-	600	0.30	1.8	45	0.20	1.4	-	-
	T9315	0.8	290	0.25	1.8	-	-	-	-	-	-	-	-	-	-	-	-	-	-
	T9325	0.8	265	0.25	1.8	155	0.23	1.8	-	-	-	-	-	55	0.20	1.4	-	-	-
	WNMG 060412E-NM	T7325	1.2	220	0.30	1.8	170	0.27	1.8	-	-	-	-	-	70	0.24	1.4	-	-
T7335		1.2	220	0.30	1.2	170	0.27	1.2	-	-	-	-	-	70	0.24	1.0	-	-	-
T9315		1.2	285	0.30	1.8	-	-	-	-	-	-	-	-	-	-	-	-	-	-
T9325		1.2	255	0.30	1.8	150	0.27	1.8	-	-	-	-	-	55	0.24	1.4	-	-	-
WNMG 080404E-NM	T7325	0.4	195	0.20	2.1	150	0.18	2.1	-	-	-	-	-	60	0.16	1.7	-	-	-
	T7335	0.4	190	0.20	2.1	145	0.18	2.1	-	-	-	-	-	60	0.16	1.7	-	-	-
	T8315	0.4	180	0.20	2.1	105	0.18	2.1	-	-	-	540	0.24	2.1	45	0.16	1.7	-	-
	T8330	0.4	170	0.20	2.1	100	0.18	2.1	-	-	-	510	0.24	2.1	40	0.16	1.7	-	-
	T8430	0.4	180	0.25	2.1	95	0.23	2.1	-	-	-	495	0.30	2.1	35	0.20	1.7	-	-
	T9315	0.4	270	0.20	2.1	-	-	-	-	-	-	-	-	-	-	-	-	-	-
	T9325	0.4	240	0.20	2.1	140	0.18	2.1	-	-	-	-	-	50	0.16	1.7	-	-	-



Kesme hızı (vc), ilerleme (f) ve kesme derinliği (ap) için uygunluk ve başlangıç değerleri. Daha ileri hesaplamalar için İşleme Hesaplayıcısı uygulamasına başvurun.

Product	RE (mm)	P			M			K			N			S			H			
		vc	f	ap	vc	f	ap	vc	f	ap	vc	f	ap	vc	f	ap	vc	f	ap	
		(m/min)	(mm/rev)	(mm)	(m/min)	(mm/rev)	(mm)	(m/min)	(mm/rev)	(mm)	(m/min)	(mm/rev)	(mm)	(m/min)	(mm/rev)	(mm)	(m/min)	(mm/rev)	(mm)	(m/min)

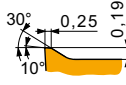

NM geometri, ince finiş, orta ve kaba işlemek için çok pozitif tasarım, darbesiz kesim için uygun.

WNMG 080408E-NM	T7325	0.8	215	0.25	2.1	165	0.23	2.1	-	-	-	-	-	-	65	0.20	1.7	-	-	-
	T7335	0.8	210	0.25	2.1	160	0.23	2.1	-	-	-	-	-	-	65	0.20	1.7	-	-	-
	T8315	0.8	205	0.25	2.1	120	0.23	2.1	-	-	-	615	0.30	2.1	50	0.20	1.7	-	-	-
	T8330	0.8	195	0.25	2.1	115	0.23	2.1	-	-	-	585	0.30	2.1	45	0.20	1.7	-	-	-
	T8430	0.8	210	0.25	2.1	115	0.23	2.1	-	-	-	585	0.30	2.1	45	0.20	1.7	-	-	-
	T9315	0.8	290	0.25	2.1	-	-	-	-	-	-	-	-	-	-	-	-	-	-	-
WNMG 080412E-NM	T7325	1.2	215	0.30	2.1	165	0.27	2.1	-	-	-	-	-	-	65	0.24	1.7	-	-	-
	T7335	1.2	210	0.30	2.1	160	0.27	2.1	-	-	-	-	-	-	65	0.24	1.7	-	-	-
	T8315	1.2	205	0.30	2.1	120	0.27	2.1	-	-	-	615	0.36	2.1	50	0.24	1.7	-	-	-
	T9325	1.2	255	0.30	2.1	150	0.27	2.1	-	-	-	-	-	-	55	0.24	1.7	-	-	-

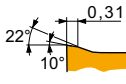

NMR geometri, ortadan kabaya kadar işlemek için pozitif tasarım, darbesiz kesim için uygun.

WNMG 060404E-NMR	T6310	0.4	145	0.25	1.6	100	0.23	1.6	-	-	-	-	-	-	40	0.20	1.3	-	-	-
	T7325	0.4	160	0.25	1.6	120	0.23	1.6	-	-	-	-	-	-	50	0.20	1.3	-	-	-
	T8430	0.4	145	0.31	1.6	80	0.28	1.6	-	-	-	-	-	-	30	0.25	1.3	-	-	-
	T9325	0.4	200	0.25	1.6	120	0.23	1.6	-	-	-	-	-	-	45	0.20	1.3	-	-	-
WNMG 060408E-NMR	T6310	0.8	155	0.35	1.6	110	0.32	1.6	-	-	-	-	-	-	45	0.25	1.3	-	-	-
	T7325	0.8	175	0.35	1.6	135	0.32	1.6	-	-	-	-	-	-	55	0.25	1.3	-	-	-
	T7335	0.8	170	0.35	1.6	130	0.32	1.6	-	-	-	-	-	-	55	0.25	1.3	-	-	-
	T9315	0.8	225	0.35	1.6	-	-	-	-	-	-	-	-	-	-	-	-	-	-	-
WNMG 080404E-NMR	T6310	0.4	140	0.25	2.7	100	0.23	2.7	-	-	-	-	-	-	40	0.20	2.2	-	-	-
	T7325	0.4	155	0.25	2.7	120	0.23	2.7	-	-	-	-	-	-	50	0.20	2.2	-	-	-
	T7335	0.4	150	0.25	2.7	115	0.23	2.7	-	-	-	-	-	-	45	0.20	2.2	-	-	-
	T8330	0.4	140	0.25	2.7	80	0.23	2.7	-	-	-	-	-	-	35	0.20	2.2	-	-	-
	T8430	0.4	140	0.31	2.7	75	0.28	2.7	-	-	-	-	-	-	30	0.25	2.2	-	-	-
	T9315	0.4	205	0.25	2.7	-	-	-	-	-	-	-	-	-	-	-	-	-	-	-
	T9325	0.4	185	0.25	2.7	110	0.23	2.7	-	-	-	-	-	-	40	0.20	2.2	-	-	-
	T9325	0.8	200	0.35	1.6	120	0.32	1.6	-	-	-	-	-	-	45	0.25	1.3	-	-	-
WNMG 080408E-NMR	T6310	0.8	150	0.35	2.7	105	0.32	2.7	-	-	-	-	-	-	45	0.25	2.2	-	-	-
	T7325	0.8	170	0.35	2.7	130	0.32	2.7	-	-	-	-	-	-	55	0.25	2.2	-	-	-
	T7335	0.8	160	0.35	2.7	120	0.32	2.7	-	-	-	-	-	-	50	0.25	2.2	-	-	-
	T8330	0.8	150	0.35	2.7	90	0.32	2.7	-	-	-	-	-	-	35	0.25	2.2	-	-	-
	T8430	0.8	155	0.35	2.7	85	0.32	2.7	-	-	-	-	-	-	30	0.25	2.2	-	-	-
	T9315	0.8	210	0.35	2.7	-	-	-	-	-	-	-	-	-	-	-	-	-	-	-
	T9325	0.8	190	0.35	2.7	110	0.32	2.7	-	-	-	-	-	-	40	0.25	2.2	-	-	-
	T9325	1.2	150	0.40	2.7	105	0.36	2.7	-	-	-	-	-	-	45	0.28	2.2	-	-	-
WNMG 080412E-NMR	T6310	1.2	170	0.40	2.7	130	0.36	2.7	-	-	-	-	-	-	55	0.28	2.2	-	-	-
	T7325	1.2	160	0.40	2.7	120	0.36	2.7	-	-	-	-	-	-	50	0.28	2.2	-	-	-
	T7335	1.2	160	0.40	2.7	120	0.36	2.7	-	-	-	-	-	-	50	0.28	2.2	-	-	-
	T8330	1.2	150	0.40	2.7	90	0.36	2.7	-	-	-	-	-	-	35	0.28	2.2	-	-	-
	T8430	1.2	155	0.40	2.7	85	0.36	2.7	-	-	-	-	-	-	30	0.28	2.2	-	-	-
	T9315	1.2	215	0.40	2.7	-	-	-	-	-	-	-	-	-	-	-	-	-	-	-
	T9325	1.2	190	0.40	2.7	110	0.36	2.7	-	-	-	-	-	-	40	0.28	2.2	-	-	-
	T9325	1.2	190	0.40	2.7	110	0.36	2.7	-	-	-	-	-	-	40	0.28	2.2	-	-	-

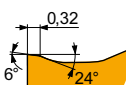

NRM geometri, orta kabadan kabaya kadar işlemek için pozitif tasarım, darbesizden darbeleri kesime kadar uygun.

WNMG 080404-NRM	T7325	0.4	155	0.25	2.7	120	0.23	2.7	-	-	-	-	-	-	50	0.18	2.2	-	-	-
	T7335	0.4	150	0.25	2.7	115	0.23	2.7	-	-	-	-	-	-	45	0.18	2.2	-	-	-
	T9315	0.4	205	0.25	2.7	-	-	-	-	-	-	-	-	-	-	-	-	-	-	-
WNMG 080408-NRM	T7325	0.8	170	0.35	2.7	130	0.32	2.7	-	-	-	-	-	-	55	0.28	2.2	-	-	-
	T7335	0.8	160	0.35	2.7	120	0.32	2.7	-	-	-	-	-	-	50	0.28	2.2	-	-	-
	T9315	0.8	210	0.35	2.7	-	-	-	-	-	-	-	-	-	-	-	-	-	-	-



Kesme hızı (vc), ilerleme (f) ve kesme derinliği (ap) için uygunluk ve başlangıç değerleri. Daha ileri hesaplamalar için İşleme Hesaplayıcısı uygulamasına başvurun.

Product	RE (mm)	P			M			K			N			S			H		
		vc (m/min)	f (mm/rev)	ap (mm)	vc (m/min)	f (mm/rev)	ap (mm)	vc (m/min)	f (mm/rev)	ap (mm)	vc (m/min)	f (mm/rev)	ap (mm)	vc (m/min)	f (mm/rev)	ap (mm)	vc (m/min)	f (mm/rev)	ap (mm)

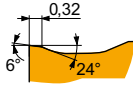
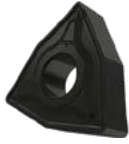

NRM geometri, orta kabadan kabaya kadar işlemek için pozitif tasarım, darbesizden darbeli kesime kadar uygun.

WNMG 080412-NRM	T7325	1.2	170	0.40	2.7	130	0.36	2.7	-	-	-	-	-	-	55	0.28	2.2	-	-	-
	T7335	1.2	160	0.40	2.7	120	0.36	2.7	-	-	-	-	-	-	50	0.28	2.2	-	-	-
	T9315	1.2	215	0.40	2.7	-	-	-	-	-	-	-	-	-	-	-	-	-	-	-

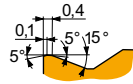

R geometri, orta kabadan kaba işleme kadar, darbesizden darbeli kesime kadar uygun.

WNMG 080408E-R	T5305	0.8	245	0.40	3.5	-	-	-	230	0.40	3.5	-	-	-	-	-	-	45	0.15	1.0
	T5315	0.8	220	0.40	3.5	-	-	-	205	0.40	3.5	-	-	-	-	-	-	40	0.15	1.0
	T9310	0.8	210	0.40	3.5	-	-	-	195	0.40	3.5	-	-	-	-	-	-	40	0.15	1.0
	T9315	0.8	195	0.40	3.5	-	-	-	185	0.40	3.5	-	-	-	-	-	-	35	0.15	1.0
	T9325	0.8	175	0.40	3.5	-	-	-	165	0.40	3.5	-	-	-	-	-	-	-	-	-
	T9335	0.8	155	0.40	3.5	-	-	-	-	-	-	-	-	-	-	-	-	-	-	-
WNMG 080412E-R	T5305	1.2	250	0.45	3.5	-	-	-	235	0.45	3.5	-	-	-	-	-	-	50	0.15	1.0
	T5315	1.2	225	0.45	3.5	-	-	-	210	0.45	3.5	-	-	-	-	-	-	45	0.15	1.0
	T9310	1.2	215	0.45	3.5	-	-	-	200	0.45	3.5	-	-	-	-	-	-	40	0.15	1.0
	T9315	1.2	200	0.45	3.5	-	-	-	190	0.45	3.5	-	-	-	-	-	-	40	0.15	1.0
	T9325	1.2	180	0.45	3.5	-	-	-	170	0.45	3.5	-	-	-	-	-	-	-	-	-
	T9335	1.2	155	0.45	3.5	-	-	-	-	-	-	-	-	-	-	-	-	-	-	-

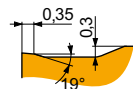

RM geometri, yarı kabadan kaba işleme kadar, ve darbesizden darbeli kesime kadar uygun.

WNMG 060412E-RM	T9310	1.2	245	0.45	3.0	-	-	-	230	0.45	3.0	-	-	-	-	-	-	-	-	-
	T9315	1.2	230	0.45	3.0	-	-	-	215	0.45	3.0	-	-	-	-	-	-	-	-	-
	T9325	1.2	230	0.45	1.2	135	0.41	1.2	215	0.45	1.2	-	-	-	-	-	-	-	-	-
WNMG 080408E-RM	T5305	0.8	275	0.40	4.0	-	-	-	260	0.40	4.0	-	-	-	-	-	-	-	-	-
	T5315	0.8	250	0.40	4.0	-	-	-	235	0.40	4.0	-	-	-	-	-	-	-	-	-
	T7325	0.8	180	0.40	4.0	140	0.36	4.0	-	-	-	-	-	-	-	-	-	-	-	-
	T7335	0.8	165	0.40	4.0	125	0.36	4.0	-	-	-	-	-	-	-	-	-	-	-	-
	T8315	0.8	165	0.40	4.0	95	0.36	4.0	155	0.40	4.0	-	-	-	-	-	-	-	-	-
	T8330	0.8	155	0.40	4.0	90	0.36	4.0	145	0.40	4.0	-	-	-	-	-	-	-	-	-
	T8430	0.8	165	0.40	4.0	90	0.36	4.0	135	0.40	4.0	-	-	-	-	-	-	-	-	-
	T9310	0.8	240	0.40	4.0	-	-	-	225	0.40	4.0	-	-	-	-	-	-	-	-	-
	T9315	0.8	220	0.40	4.0	-	-	-	205	0.40	4.0	-	-	-	-	-	-	-	-	-
	T9325	0.8	200	0.40	4.0	120	0.36	4.0	190	0.40	4.0	-	-	-	-	-	-	-	-	-
	T9335	0.8	170	0.40	4.0	100	0.36	4.0	-	-	-	-	-	-	-	-	-	-	-	-
	WNMG 080412E-RM	T5305	1.2	280	0.45	4.0	-	-	-	265	0.45	4.0	-	-	-	-	-	-	-	-
T5315		1.2	250	0.45	4.0	-	-	-	235	0.45	4.0	-	-	-	-	-	-	-	-	-
T7325		1.2	180	0.45	4.0	140	0.41	4.0	-	-	-	-	-	-	-	-	-	-	-	
T7335		1.2	170	0.45	4.0	130	0.41	4.0	-	-	-	-	-	-	-	-	-	-	-	
T8315		1.2	170	0.45	4.0	100	0.41	4.0	160	0.45	4.0	-	-	-	-	-	-	-	-	
T9310		1.2	240	0.45	4.0	-	-	-	225	0.45	4.0	-	-	-	-	-	-	-	-	-
T9315		1.2	220	0.45	4.0	-	-	-	205	0.45	4.0	-	-	-	-	-	-	-	-	-
T9325		1.2	200	0.45	4.0	120	0.41	4.0	190	0.45	4.0	-	-	-	-	-	-	-	-	-
T9335		1.2	175	0.45	4.0	105	0.41	4.0	-	-	-	-	-	-	-	-	-	-	-	
WNMG 080416E-RM	T5305	1.6	280	0.50	4.0	-	-	-	265	0.50	4.0	-	-	-	-	-	-	-	-	-
	T5315	1.6	255	0.50	4.0	-	-	-	240	0.50	4.0	-	-	-	-	-	-	-	-	-
	T7335	1.6	175	0.50	4.0	135	0.45	4.0	-	-	-	-	-	-	-	-	-	-	-	
	T8430	1.6	170	0.50	4.0	90	0.45	4.0	135	0.50	4.0	-	-	-	-	-	-	-	-	
	T9310	1.6	240	0.50	4.0	-	-	-	225	0.50	4.0	-	-	-	-	-	-	-	-	
	T9315	1.6	220	0.50	4.0	-	-	-	205	0.50	4.0	-	-	-	-	-	-	-	-	
	T9325	1.6	205	0.50	4.0	120	0.45	4.0	190	0.50	4.0	-	-	-	-	-	-	-	-	
	T9335	1.6	175	0.50	4.0	105	0.45	4.0	-	-	-	-	-	-	-	-	-	-		



Kesme hızı (vc), ilerleme (f) ve kesme derinliği (ap) için uygunluk ve başlangıç değerleri. Daha ileri hesaplamalar için İşleme Hesaplayıcısı uygulamasına başvurun.

Product	RE (mm)	P			M			K			N			S			H		
		vc (m/min)	f (mm/rev)	ap (mm)	vc (m/min)	f (mm/rev)	ap (mm)	vc (m/min)	f (mm/rev)	ap (mm)	vc (m/min)	f (mm/rev)	ap (mm)	vc (m/min)	f (mm/rev)	ap (mm)	vc (m/min)	f (mm/rev)	ap (mm)

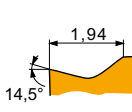

SF geometri, ince finiş ve ince cidar işlemek için pozitif tasarım, darbesiz kesim için uygun.

WNMG 060404E-SF	H07	0.4	–	–	–	90	0.14	1.0	145	0.15	1.0	470	0.18	1.0	45	0.12	0.8	–	–	–
	T6310	0.4	180	0.15	1.0	125	0.14	1.0	145	0.15	1.0	540	0.18	1.0	50	0.12	0.8	35	0.15	1.0
	T7325	0.4	205	0.17	1.0	155	0.15	1.0	–	–	–	–	–	–	65	0.15	0.8	–	–	–
	T7335	0.4	200	0.17	1.0	155	0.15	1.0	–	–	–	–	–	–	65	0.15	0.8	–	–	–
	T8315	0.4	195	0.15	1.0	115	0.14	1.0	185	0.15	1.0	585	0.18	1.0	45	0.12	0.8	35	0.15	1.0
	T8330	0.4	180	0.15	1.0	105	0.14	1.0	170	0.15	1.0	540	0.18	1.0	45	0.12	0.8	35	0.15	1.0
	T8430	0.4	220	0.15	1.0	120	0.14	1.0	180	0.15	1.0	600	0.18	1.0	45	0.12	0.8	35	0.15	1.0
	T9325	0.4	255	0.17	1.0	150	0.15	1.0	240	0.17	1.0	–	–	–	55	0.15	0.8	–	–	–
	T9315	0.8	–	–	–	95	0.18	1.0	155	0.20	1.0	495	0.24	1.0	50	0.14	0.8	–	–	–
WNMG 060408E-SF	T6310	0.8	200	0.20	1.0	140	0.18	1.0	160	0.20	1.0	600	0.24	1.0	60	0.14	0.8	40	0.15	1.0
	T7335	0.8	220	0.20	1.0	170	0.18	1.0	–	–	–	–	–	70	0.16	0.8	–	–	–	
	T8315	0.8	210	0.20	1.0	125	0.18	1.0	195	0.20	1.0	630	0.24	1.0	50	0.14	0.8	40	0.15	1.0
	T8330	0.8	200	0.20	1.0	120	0.18	1.0	190	0.20	1.0	600	0.24	1.0	50	0.14	0.8	40	0.15	1.0
	T8430	0.8	230	0.20	1.0	125	0.18	1.0	185	0.20	1.0	630	0.24	1.0	45	0.14	0.8	35	0.15	1.0
	T9315	0.8	315	0.20	1.0	–	–	–	295	0.20	1.0	–	–	–	–	–	–	60	0.15	1.0
	T9325	0.8	280	0.20	1.0	165	0.18	1.0	265	0.20	1.0	–	–	–	60	0.16	0.8	–	–	–
	H07	0.4	–	–	–	90	0.14	1.0	145	0.15	1.0	470	0.18	1.0	45	0.12	0.8	–	–	–
	T6310	0.4	180	0.15	1.0	125	0.14	1.0	145	0.15	1.0	540	0.18	1.0	50	0.12	0.8	35	0.15	1.0
WNMG 080404E-SF	T7325	0.4	205	0.17	1.0	155	0.15	1.0	–	–	–	–	–	65	0.15	0.8	–	–	–	
	T7335	0.4	200	0.17	1.0	155	0.15	1.0	–	–	–	–	–	65	0.15	0.8	–	–	–	
	T8315	0.4	195	0.15	1.0	115	0.14	1.0	185	0.15	1.0	585	0.18	1.0	45	0.12	0.8	35	0.15	1.0
	T8330	0.4	180	0.15	1.0	105	0.14	1.0	170	0.15	1.0	540	0.18	1.0	45	0.12	0.8	35	0.15	1.0
	T8430	0.4	220	0.15	1.0	120	0.14	1.0	180	0.15	1.0	600	0.18	1.0	45	0.12	0.8	35	0.15	1.0
	T9315	0.4	300	0.15	1.0	–	–	–	285	0.15	1.0	–	–	–	–	–	–	60	0.15	1.0
	T9325	0.4	255	0.17	1.0	150	0.15	1.0	240	0.17	1.0	–	–	–	55	0.15	0.8	–	–	–
	H07	0.8	–	–	–	95	0.18	1.0	155	0.20	1.0	495	0.24	1.0	50	0.14	0.8	–	–	–
	T6310	0.8	200	0.20	1.0	140	0.18	1.0	160	0.20	1.0	600	0.24	1.0	60	0.14	0.8	40	0.15	1.0
WNMG 080408E-SF	T7325	0.8	230	0.20	1.0	175	0.18	1.0	–	–	–	–	–	70	0.16	0.8	–	–	–	
	T7335	0.8	220	0.20	1.0	170	0.18	1.0	–	–	–	–	–	70	0.16	0.8	–	–	–	
	T8315	0.8	210	0.20	1.0	125	0.18	1.0	195	0.20	1.0	630	0.24	1.0	50	0.14	0.8	40	0.15	1.0
	T8330	0.8	200	0.20	1.0	120	0.18	1.0	190	0.20	1.0	600	0.24	1.0	50	0.14	0.8	40	0.15	1.0
	T8430	0.8	230	0.20	1.0	125	0.18	1.0	185	0.20	1.0	630	0.24	1.0	45	0.14	0.8	35	0.15	1.0
	T9315	0.8	315	0.20	1.0	–	–	–	295	0.20	1.0	–	–	–	–	–	–	60	0.15	1.0
	T9325	0.8	280	0.20	1.0	165	0.18	1.0	265	0.20	1.0	–	–	–	60	0.16	0.8	–	–	–
	H07	1.2	220	0.25	1.5	170	0.23	1.5	–	–	–	–	–	–	70	0.18	1.2	–	–	–

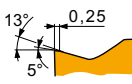

SM geometri, orta işleme için pozitif tasarım, darbesizden darbeli kesime kadar uygun.

WNMG 060404E-SM	T7325	0.4	180	0.22	1.7	140	0.20	1.7	–	–	–	–	–	55	0.20	1.4	–	–	–	
	T7335	0.4	175	0.22	1.7	135	0.20	1.7	–	–	–	–	–	55	0.20	1.4	–	–	–	
	T8330	0.4	155	0.22	1.7	90	0.20	1.7	145	0.22	1.7	465	0.26	1.7	35	0.20	1.4	30	0.15	1.0
	T8430	0.4	175	0.22	1.7	95	0.20	1.7	140	0.22	1.7	480	0.26	1.7	35	0.20	1.4	30	0.15	1.0
	T9315	0.4	250	0.20	1.7	–	–	–	235	0.20	1.7	–	–	–	–	–	–	50	0.15	1.0
	T9325	0.4	215	0.22	1.7	125	0.20	1.7	200	0.22	1.7	–	–	–	45	0.20	1.4	–	–	–
WNMG 060408E-SM	T6310	0.8	175	0.25	1.7	125	0.23	1.7	140	0.25	1.7	525	0.30	1.7	50	0.20	1.4	35	0.15	1.0
	T7325	0.8	200	0.25	1.7	155	0.23	1.7	–	–	–	–	–	65	0.20	1.4	–	–	–	
	T7335	0.8	195	0.25	1.7	150	0.23	1.7	–	–	–	–	–	60	0.20	1.4	–	–	–	
	T8330	0.8	175	0.25	1.7	105	0.23	1.7	165	0.25	1.7	525	0.30	1.7	40	0.20	1.4	35	0.15	1.0
	T8430	0.8	195	0.25	1.7	105	0.23	1.7	160	0.25	1.7	540	0.30	1.7	40	0.20	1.4	30	0.15	1.0
	T9325	0.8	240	0.25	1.7	140	0.23	1.7	225	0.25	1.7	–	–	–	50	0.20	1.4	–	–	–
WNMG 060412E-SM	T7325	1.2	200	0.30	1.7	155	0.27	1.7	–	–	–	–	–	65	0.24	1.4	–	–	–	
	T8330	1.2	180	0.30	1.7	105	0.27	1.7	170	0.30	1.7	540	0.36	1.7	45	0.24	1.4	35	0.15	1.0
	T8430	1.2	195	0.30	1.7	105	0.27	1.7	160	0.30	1.7	540	0.36	1.7	40	0.24	1.4	30	0.15	1.0
	T9325	1.2	240	0.30	1.7	140	0.27	1.7	225	0.30	1.7	–	–	–	50	0.24	1.4	–	–	–



Kesme hızı (vc), ilerleme (f) ve kesme derinliği (ap) için uygunluk ve başlangıç değerleri. Daha ileri hesaplamalar için İşleme Hesaplayıcısı uygulamasına başvurun.

Product	RE (mm)	P			M			K			N			S			H		
		vc (m/min)	f (mm/rev)	ap (mm)	vc (m/min)	f (mm/rev)	ap (mm)	vc (m/min)	f (mm/rev)	ap (mm)	vc (m/min)	f (mm/rev)	ap (mm)	vc (m/min)	f (mm/rev)	ap (mm)	vc (m/min)	f (mm/rev)	ap (mm)

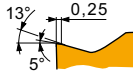

SM geometri, orta işleme için pozitif tasarım, darbesizden darbeleri kesime kadar uygun.

WNMG 080404E-SM	T6310	0.4	155	0.22	2.0	110	0.20	2.0	125	0.22	2.0	465	0.26	2.0	45	0.20	1.6	30	0.15	1.0
	T7325	0.4	175	0.22	2.0	135	0.20	2.0	-	-	-	-	-	-	55	0.20	1.6	-	-	-
	T7335	0.4	170	0.22	2.0	130	0.20	2.0	-	-	-	-	-	-	55	0.20	1.6	-	-	-
	T8330	0.4	155	0.22	2.0	90	0.20	2.0	145	0.22	2.0	465	0.26	2.0	35	0.20	1.6	30	0.15	1.0
	T8430	0.4	170	0.22	2.0	90	0.20	2.0	135	0.22	2.0	465	0.26	2.0	35	0.20	1.6	25	0.15	1.0
	T9315	0.4	245	0.20	2.0	-	-	-	230	0.20	2.0	-	-	-	-	-	-	45	0.15	1.0
WNMG 080408E-SM	T6310	0.8	175	0.25	2.0	125	0.23	2.0	140	0.25	2.0	525	0.30	2.0	50	0.20	1.6	35	0.15	1.0
	T7325	0.8	200	0.25	2.0	155	0.23	2.0	-	-	-	-	-	65	0.20	1.6	-	-	-	
	T7335	0.8	190	0.25	2.0	145	0.23	2.0	-	-	-	-	-	60	0.20	1.6	-	-	-	
	T8330	0.8	175	0.25	2.0	105	0.23	2.0	165	0.25	2.0	525	0.30	2.0	40	0.20	1.6	35	0.15	1.0
	T8430	0.8	195	0.25	2.0	105	0.23	2.0	160	0.25	2.0	540	0.30	2.0	40	0.20	1.6	30	0.15	1.0
	T9315	0.8	265	0.25	2.0	-	-	-	250	0.25	2.0	-	-	-	-	-	50	0.15	1.0	-
WNMG 080412E-SM	T6310	1.2	175	0.30	2.0	125	0.27	2.0	140	0.30	2.0	525	0.36	2.0	50	0.24	1.6	35	0.15	1.0
	T7325	1.2	195	0.30	2.0	150	0.27	2.0	-	-	-	-	-	60	0.24	1.6	-	-	-	
	T7335	1.2	190	0.30	2.0	145	0.27	2.0	-	-	-	-	-	60	0.24	1.6	-	-	-	
	T8330	1.2	175	0.30	2.0	105	0.27	2.0	165	0.30	2.0	525	0.36	2.0	40	0.24	1.6	35	0.15	1.0
	T8430	1.2	190	0.30	2.0	105	0.27	2.0	155	0.30	2.0	525	0.36	2.0	40	0.24	1.6	30	0.15	1.0
	T9315	1.2	260	0.30	2.0	-	-	-	245	0.30	2.0	-	-	-	-	-	50	0.15	1.0	-

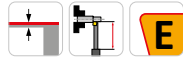
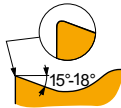

ER-SI geometri, çok pozitif sağ kesme yönlü tasarım, ince finişten yarı kaba işlemeye kadar, ve darbesiz kesim için uygun.

WNMG 060404ER-SI	T8330	0.4	195	0.20	1.7	115	0.18	1.7	-	-	-	585	0.24	1.7	45	0.18	1.4	-	-	-
	T8430	0.4	225	0.20	1.7	120	0.18	1.7	-	-	-	615	0.24	1.7	45	0.18	1.4	-	-	-
	T9325	0.4	270	0.20	1.7	160	0.18	1.7	-	-	-	-	-	-	60	0.18	1.4	-	-	-
WNMG 080404ER-SI	T7325	0.4	220	0.20	1.7	170	0.18	1.7	-	-	-	-	-	-	70	0.18	1.4	-	-	-
	T7335	0.4	215	0.20	1.7	165	0.18	1.7	-	-	-	-	-	-	65	0.18	1.4	-	-	-
	T8315	0.4	205	0.20	1.7	120	0.18	1.7	-	-	-	615	0.24	1.7	50	0.18	1.4	-	-	-
	T8330	0.4	195	0.20	1.7	115	0.18	1.7	-	-	-	585	0.24	1.7	45	0.18	1.4	-	-	-
	T8430	0.4	225	0.20	1.7	120	0.18	1.7	-	-	-	615	0.24	1.7	45	0.18	1.4	-	-	-
	T9325	0.4	270	0.20	1.7	160	0.18	1.7	-	-	-	-	-	-	60	0.18	1.4	-	-	-
WNMG 080408ER-SI	T7325	0.8	215	0.35	1.7	165	0.32	1.7	-	-	-	-	-	-	65	0.25	1.4	-	-	-
	T7335	0.8	205	0.35	1.7	155	0.32	1.7	-	-	-	-	-	-	65	0.25	1.4	-	-	-
	T8315	0.8	205	0.35	1.7	120	0.32	1.7	-	-	-	615	0.42	1.7	50	0.25	1.4	-	-	-
	T8330	0.8	195	0.35	1.7	115	0.32	1.7	-	-	-	585	0.42	1.7	45	0.25	1.4	-	-	-
	T8430	0.8	210	0.35	1.7	115	0.32	1.7	-	-	-	585	0.42	1.7	45	0.25	1.4	-	-	-
	T9325	0.8	255	0.35	1.7	150	0.32	1.7	-	-	-	-	-	-	55	0.25	1.4	-	-	-
WNMG 080412ER-SI	T8430	1.2	225	0.35	1.7	120	0.32	1.7	-	-	-	615	0.42	1.7	45	0.25	1.4	-	-	-
	T9325	1.2	265	0.35	1.7	155	0.32	1.7	-	-	-	-	-	-	55	0.25	1.4	-	-	-

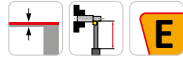
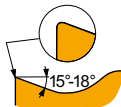

EL-SI geometri, çok pozitif sol kesme yönlü tasarım, ince finişten yarı kaba işlemeye kadar, ve darbesiz kesim için uygun.

WNMG 060404EL-SI	T8330	0.4	195	0.20	1.7	115	0.18	1.7	-	-	-	585	0.24	1.7	45	0.18	1.4	-	-	-
	T8430	0.4	225	0.20	1.7	120	0.18	1.7	-	-	-	615	0.24	1.7	45	0.18	1.4	-	-	-
	T9325	0.4	270	0.20	1.7	160	0.18	1.7	-	-	-	-	-	-	60	0.18	1.4	-	-	-
WNMG 080404EL-SI	T7325	0.4	220	0.20	1.7	170	0.18	1.7	-	-	-	-	-	-	70	0.18	1.4	-	-	-
	T7335	0.4	215	0.20	1.7	165	0.18	1.7	-	-	-	-	-	-	65	0.18	1.4	-	-	-
	T8315	0.4	205	0.20	1.7	120	0.18	1.7	-	-	-	615	0.24	1.7	50	0.18	1.4	-	-	-
	T8330	0.4	195	0.20	1.7	115	0.18	1.7	-	-	-	585	0.24	1.7	45	0.18	1.4	-	-	-
	T8430	0.4	225	0.20	1.7	120	0.18	1.7	-	-	-	615	0.24	1.7	45	0.18	1.4	-	-	-
	T9325	0.4	270	0.20	1.7	160	0.18	1.7	-	-	-	-	-	-	60	0.18	1.4	-	-	-



Kesme hızı (vc), ilerleme (f) ve kesme derinliği (ap) için uygunluk ve başlangıç değerleri. Daha ileri hesaplamalar için İşleme Hesaplayıcısı uygulamasına başvurun.

Product	RE (mm)	P			M			K			N			S			H		
		vc (m/min)	f (mm/rev)	ap (mm)	vc (m/min)	f (mm/rev)	ap (mm)	vc (m/min)	f (mm/rev)	ap (mm)	vc (m/min)	f (mm/rev)	ap (mm)	vc (m/min)	f (mm/rev)	ap (mm)	vc (m/min)	f (mm/rev)	ap (mm)

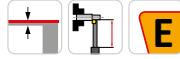
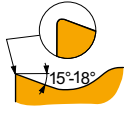

EL-SI geometri, çok pozitif sol kesme yönlü tasarım, ince finişten yarı kaba işleme kadar, ve darbesiz kesim için uygun.

WNMG 080408EL-SI	T7325	0.8	215	0.35	1.7	165	0.32	1.7	-	-	-	65	0.25	1.4	-	-	-	
	T7335	0.8	205	0.35	1.7	155	0.32	1.7	-	-	-	65	0.25	1.4	-	-	-	
	T8315	0.8	205	0.35	1.7	120	0.32	1.7	-	-	615	0.42	1.7	50	0.25	1.4	-	-
	T8330	0.8	195	0.35	1.7	115	0.32	1.7	-	-	585	0.42	1.7	45	0.25	1.4	-	-
	T8430	0.8	210	0.35	1.7	115	0.32	1.7	-	-	585	0.42	1.7	45	0.25	1.4	-	-
	T9325	0.8	255	0.35	1.7	150	0.32	1.7	-	-	-	-	-	55	0.25	1.4	-	-
WNMG 080412EL-SI	T8430	1.2	225	0.35	1.7	120	0.32	1.7	-	-	615	0.42	1.7	45	0.25	1.4	-	-

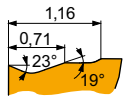

W-F wiper geometri, inceden finişe kadar işleme, yüksek ilerleme hızları ve iyileştirilmiş yüzey finışı için.

WNMG 060408W-F	T9315	0.8	215	0.45	0.8	-	-	-	200	0.45	0.8	-	-	-	-	-	-
	T9325	0.8	190	0.45	0.8	-	-	-	180	0.45	0.8	-	-	-	-	-	-
WNMG 080404W-F	T9315	0.4	250	0.25	0.4	-	-	-	235	0.25	0.4	-	-	-	-	-	-
	T9325	0.4	225	0.25	0.4	-	-	-	210	0.25	0.4	-	-	-	-	-	-

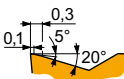

W-M wiper geometri, yarı kabadan kabaya kadar işleme, yüksek ilerleme hızları ve iyileştirilmiş yüzey finışı için.

WNMG 060408W-M	T9310	0.8	220	0.45	1.2	-	-	-	205	0.45	1.2	-	-	-	-	-	-
	T9315	0.8	205	0.45	1.2	-	-	-	190	0.45	1.2	-	-	-	-	-	-
	T9325	0.8	190	0.45	1.2	-	-	-	180	0.45	1.2	-	-	-	-	-	-
WNMG 060412W-M	T5315	1.2	235	0.55	1.2	-	-	-	220	0.55	1.2	-	-	-	-	-	-
	T9315	1.2	205	0.55	1.2	-	-	-	190	0.55	1.2	-	-	-	-	-	-
	T9325	1.2	180	0.55	1.2	-	-	-	170	0.55	1.2	-	-	-	-	-	-
WNMG 080408W-M	T9315	0.8	200	0.45	1.5	-	-	-	190	0.45	1.5	-	-	-	-	-	-
	T9325	0.8	185	0.45	1.5	-	-	-	175	0.45	1.5	-	-	-	-	-	-
WNMG 080412W-M	T9325	1.2	180	0.55	1.5	-	-	-	170	0.55	1.5	-	-	-	-	-	-

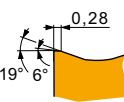

W-MR wiper geometri, finişten kabaya kadar işleme, yüksek ilerleme hızları ve iyileştirilmiş yüzey finışı için.

WNMG 060408W-MR	T9315	0.8	205	0.45	1.2	-	-	-	190	0.45	1.2	-	-	-	-	-	-
	T9325	0.8	190	0.45	1.2	110	0.41	1.2	180	0.45	1.2	-	-	-	-	-	-
WNMG 080404W-MR	T9315	0.4	200	0.30	1.5	-	-	-	190	0.30	1.5	-	-	-	-	-	-
	T9325	0.4	180	0.30	1.5	105	0.27	1.5	170	0.30	1.5	-	-	-	-	-	-
WNMG 080408W-MR	T5315	0.8	230	0.45	1.5	-	-	-	215	0.45	1.5	-	-	-	-	-	-
	T9310	0.8	215	0.45	1.5	-	-	-	200	0.45	1.5	-	-	-	-	-	-
	T9315	0.8	200	0.45	1.5	-	-	-	190	0.45	1.5	-	-	-	-	-	-
WNMG 080412W-MR	T9325	0.8	185	0.45	1.5	110	0.41	1.5	175	0.45	1.5	-	-	-	-	-	-
	T5315	1.2	230	0.55	1.5	-	-	-	215	0.55	1.5	-	-	-	-	-	-
	T9310	1.2	210	0.55	1.5	-	-	-	195	0.55	1.5	-	-	-	-	-	-
	T9315	1.2	200	0.55	1.5	-	-	-	190	0.55	1.5	-	-	-	-	-	-
WNMG 080412W-MR	T9325	1.2	180	0.55	1.5	105	0.50	1.5	170	0.55	1.5	-	-	-	-	-	-

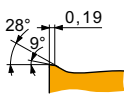

W-NR wiper geometri, finişten kabaya kadar işleme, yüksek ilerleme hızları ve iyileştirilmiş yüzey finışı için.

WNMG 060408W-NM	T7325	0.8	220	0.25	1.8	170	0.23	1.8	-	-	-	70	0.20	1.4	-	-	-
	T7335	0.8	215	0.25	1.8	165	0.23	1.8	-	-	-	65	0.20	1.4	-	-	-
	T9315	0.8	290	0.25	1.8	-	-	-	275	0.25	1.8	-	-	-	-	-	-
	T9325	0.8	265	0.25	1.8	155	0.23	1.8	250	0.25	1.8	-	-	-	55	0.20	1.4



Kesme hızı (vc), ilerleme (f) ve kesme derinliği (ap) için uygunluk ve başlangıç değerleri. Daha ileri hesaplamalar için İşleme Hesaplayıcısı uygulamasına başvurun.

Product	RE (mm)	P			M			K			N			S			H		
		vc (m/min)	f (mm/rev)	ap (mm)	vc (m/min)	f (mm/rev)	ap (mm)	vc (m/min)	f (mm/rev)	ap (mm)	vc (m/min)	f (mm/rev)	ap (mm)	vc (m/min)	f (mm/rev)	ap (mm)	vc (m/min)	f (mm/rev)	ap (mm)

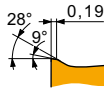

W-NR wiper geometri, finiştan kabaya kadar işleme, yüksek ilerleme hızları ve iyileştirilmiş yüzey finışı için.

WNMG 080404W-NM	T7325	0.4	195	0.20	2.1	150	0.18	2.1	-	-	-	-	-	-	60	0.16	1.7	-	-	-
	T7335	0.4	190	0.20	2.1	145	0.18	2.1	-	-	-	-	-	-	60	0.16	1.7	-	-	-
	T9315	0.4	270	0.20	2.1	-	-	-	255	0.20	2.1	-	-	-	-	-	-	-	-	-
	T9325	0.4	240	0.20	2.1	140	0.18	2.1	225	0.20	2.1	-	-	-	50	0.16	1.7	-	-	-
WNMG 080408W-NM	T7325	0.8	215	0.25	2.1	165	0.23	2.1	-	-	-	-	-	-	65	0.20	1.7	-	-	-
	T7335	0.8	210	0.25	2.1	160	0.23	2.1	-	-	-	-	-	-	65	0.20	1.7	-	-	-
	T9315	0.8	290	0.25	2.1	-	-	-	275	0.25	2.1	-	-	-	-	-	-	-	-	-
	T9325	0.8	260	0.25	2.1	155	0.23	2.1	245	0.25	2.1	-	-	-	55	0.20	1.7	-	-	-
WNMG 080412W-NM	T7325	1.2	215	0.30	2.1	165	0.27	2.1	-	-	-	-	-	-	65	0.24	1.7	-	-	-
	T7335	1.2	210	0.30	2.1	160	0.27	2.1	-	-	-	-	-	-	65	0.24	1.7	-	-	-
	T9315	1.2	285	0.30	2.1	-	-	-	270	0.30	2.1	-	-	-	-	-	-	-	-	-

WNMM



	IC (mm)	D1 (mm)	L (mm)	S (mm)
0804	12.700	5.16	8.70	4.76
1006	15.875	6.35	10.80	6.35
1306	19.050	7.94	13.00	6.35

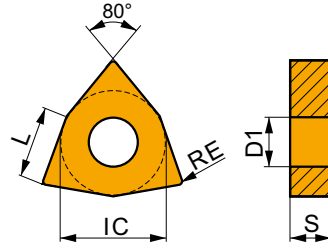

Kesme hızı (vc), ilerleme (f) ve kesme derinliği (ap) için uygunluk ve başlangıç değerleri. Daha ileri hesaplamalar için İşleme Hesaplayıcısı uygulamasına başvurun.

Product	RE (mm)	P			M			K			N			S			H		
		vc (m/min)	f (mm/rev)	ap (mm)	vc (m/min)	f (mm/rev)	ap (mm)	vc (m/min)	f (mm/rev)	ap (mm)	vc (m/min)	f (mm/rev)	ap (mm)	vc (m/min)	f (mm/rev)	ap (mm)	vc (m/min)	f (mm/rev)	ap (mm)

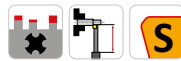
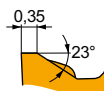

DR geometri, yarı kabadan kaba işlemeye, ve sürekliden aralıklı kesmeye kadar uygun.

WNMM 100608E-DR	T9325	0.8	205	0.40	5.0	120	0.36	5.0	190	0.40	5.0	-	-	-	-	-	-	-	-
	T9335	0.8	175	0.40	5.0	105	0.36	5.0	-	-	-	-	-	-	-	-	-	-	-
WNMM 130612E-DR	T9325	1.2	200	0.45	6.0	120	0.41	6.0	190	0.45	6.0	-	-	-	-	-	-	-	-
	T9335	1.2	170	0.45	6.0	100	0.41	6.0	-	-	-	-	-	-	-	-	-	-	-

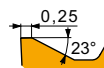

NR geometri, yarı kabadan kaba işlemeye kadar, darbesizden darbeli kesime kadar uygun.

WNMM 080408E-NR	T7325	0.8	175	0.40	3.0	135	0.36	3.0	-	-	-	-	-	-	55	0.28	2.4	-	-	-
	T8330	0.8	155	0.40	3.0	90	0.36	3.0	145	0.40	3.0	-	-	-	35	0.28	2.4	-	-	-
	T8430	0.8	165	0.40	3.0	90	0.36	3.0	135	0.40	3.0	-	-	-	35	0.28	2.4	-	-	-
	T9325	0.8	195	0.40	3.0	115	0.36	3.0	185	0.40	3.0	-	-	-	40	0.28	2.4	-	-	-

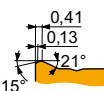



NR2 geometri, yarı kabadan kaba işlemeye kadar, darbesizden darbeli kesime kadar uygun.

WNMM 080408E-NR2	T7335	0.8	160	0.40	4.0	120	0.36	4.0	-	-	-	-	-	-	50	0.28	3.2	-	-	-
	T9325	0.8	190	0.40	4.0	110	0.36	4.0	180	0.40	4.0	-	-	-	40	0.28	3.2	-	-	-



Kesme hızı (vc), ilerleme (f) ve kesme derinliği (ap) için uygunluk ve başlangıç değerleri. Daha ileri hesaplamalar için İşleme Hesaplayıcısı uygulamasına başvurun.

Product	RE (mm)	P			M			K			N			S			H			
		vc (m/min)	f (mm/rev)	ap (mm)	vc (m/min)	f (mm/rev)	ap (mm)	vc (m/min)	f (mm/rev)	ap (mm)	vc (m/min)	f (mm/rev)	ap (mm)	vc (m/min)	f (mm/rev)	ap (mm)	vc (m/min)	f (mm/rev)	ap (mm)	
 0,41 0,13 21° 15°																				
 0,22+0,45 0,1+0,15 4° 18°																				
WNMM 080412E-NR2	T7325	1.2	175	0.45	4.0	135	0.41	4.0	—	—	—	—	—	—	55	0.32	3.2	—	—	—
	T9325	1.2	190	0.45	4.0	110	0.41	4.0	180	0.45	4.0	—	—	—	40	0.32	3.2	—	—	—
	T8330	0.8	150	0.40	4.0	90	0.36	4.0	140	0.40	4.0	—	—	—	35	0.28	3.2	—	—	—
	T8430	0.8	155	0.40	4.0	85	0.36	4.0	130	0.40	4.0	—	—	—	30	0.28	3.2	—	—	—
WNMM 080412E-OR	T9325	1.2	190	0.45	4.0	110	0.41	4.0	180	0.45	4.0	—	—	—	40	0.36	3.2	—	—	—
	T9335	1.2	170	0.45	4.0	100	0.41	4.0	—	—	—	—	—	35	0.36	3.2	—	—	—	
WNMM 080416E-OR	T9325	1.6	195	0.50	4.0	115	0.45	4.0	185	0.50	4.0	—	—	—	40	0.40	3.2	—	—	—
WNMM 130612E-OR	T9325	1.2	185	0.45	6.0	110	0.41	6.0	175	0.45	6.0	—	—	—	40	0.36	4.8	—	—	—
WNMM 130616E-OR	T9325	1.6	180	0.50	6.0	105	0.45	6.0	170	0.50	6.0	—	—	—	40	0.40	4.8	—	—	—



WNGA CBN

PRAMET

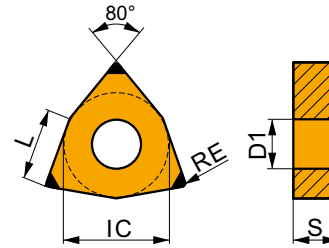
	IC (mm)	D1 (mm)	L (mm)	S (mm)
0804	12.700	5.16	8.70	4.76



Kesme hızı (vc), ilerleme (f) ve kesme derinliği (ap) için uygunluk ve başlangıç değerleri. Daha ileri hesaplamalar için İşleme Hesaplayıcısı uygulamasına başvurun.

Product	RE (mm)	P			M			K			N			S			H			
		vc (m/min)	f (mm/rev)	ap (mm)	vc (m/min)	f (mm/rev)	ap (mm)	vc (m/min)	f (mm/rev)	ap (mm)	vc (m/min)	f (mm/rev)	ap (mm)	vc (m/min)	f (mm/rev)	ap (mm)	vc (m/min)	f (mm/rev)	ap (mm)	
 HSC S																				
WNGA 080408S01020C	TB310	0.8	—	—	—	—	—	—	530	0.15	0.6	—	—	—	140	0.11	0.5	110	0.15	1.0
 W HSC S																				
WNGA080408S01020WC	TB310	0.8	—	—	—	—	—	—	530	0.15	0.6	—	—	—	140	0.11	0.5	110	0.15	1.0



DWLN(RL) EXT



PRAMET

D

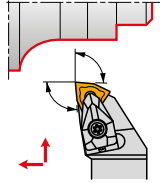

WN.. Uç için Çift Sıkmalı, 95° Açılı Dış Kater

Çift sıkmalı, 95° açılı, içten su vermeli Sağ/Sol dış kater. Negatif WN.. 06 - 13 uçlarla çap, alın, konik ve pah tornalamak için uygundur. 16x16 - 40x40mm şaftlı mevcuttur. Tutucu uzun takım ömrü için işlem görmüştür.

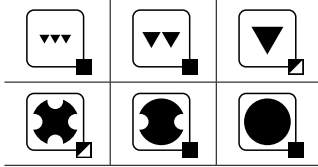
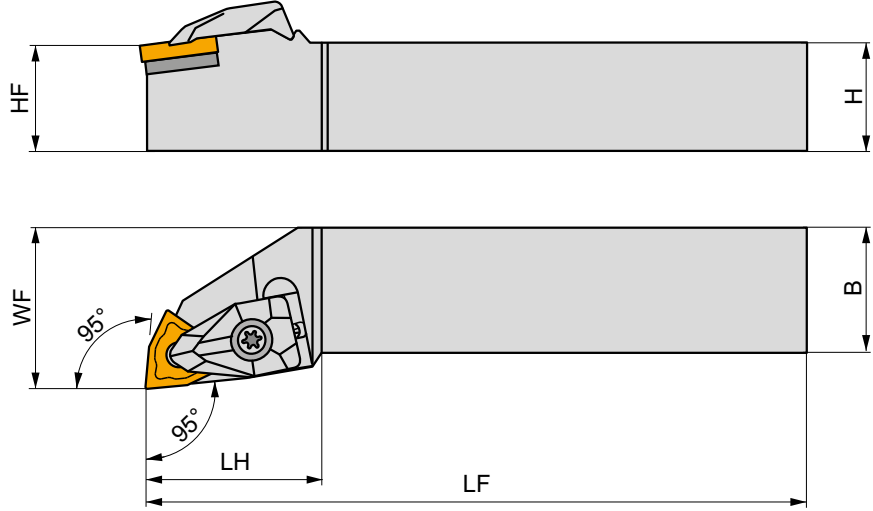

Product	H	B	HF	WF	LF	LH	LAMS	GAMO	kg				
	(mm)	(mm)	(mm)	(mm)	(mm)	(mm)	(°)	(°)					
R	DWLN R 1616 H 06	16	16	16	20	100	26.4	-6	-6	0.22	GI028	DW06	-
	DWLN R 2020 K 06	20	20	20	25	125	27.1	-6	-6	0.41	GI028	DW06	-
	DWLN R 2525 M 06	25	25	25	32	150	27.1	-6	-6	0.75	GI028	DW06	-
	DWLN R 2020 K 08	20	20	20	25	125	34.3	-6	-6	0.43	GI072	DW08	AT004
	DWLN R 2525 M 08	25	25	25	32	150	35	-6	-6	0.75	GI072	DW08	AT004
	DWLN R 3225 P 08	32	25	32	32	170	35	-6	-6	1.01	GI072	DW08	AT004
	DWLN R 3225 P 10	32	25	32	32	170	38	-6	-6	1.06	GI166	DW10	-
	DWLN R 3232 P 13	32	32	32	40	170	40	-6	-6	1.44	GI167	DW13	-
	DWLN R 4040 S 13	40	40	40	50	250	41	-6	-6	3.19	GI167	DW13	-
	L	DWLN L 1616 H 06	16	16	16	20	100	26.4	-6	-6	0.22	GI028	DW06
DWLN L 2020 K 06		20	20	20	25	125	27.1	-6	-6	0.41	GI028	DW06	-
DWLN L 2525 M 06		25	25	25	32	150	27.1	-6	-6	0.76	GI028	DW06	-
DWLN L 2020 K 08		20	20	20	25	125	34.3	-6	-6	0.43	GI072	DW08	AT004
DWLN L 2525 M 08		25	25	25	32	150	35	-6	-6	0.75	GI072	DW08	AT004
DWLN L 3225 P 08		32	25	32	32	170	35	-6	-6	1.10	GI072	DW08	AT004
DWLN L 3225 P 10		32	25	32	32	170	38	-6	-6	1.14	GI166	DW10	-
DWLN L 3232 P 13		32	32	32	40	170	40	-6	-6	1.45	GI167	DW13	-
DWLN L 4040 S 13		40	40	40	50	250	41	-6	-6	3.17	GI167	DW13	-



GI028

WN.. 0604..

GI072

WN.. 0804..







GI166



WN.. 1006..

GI167

WN.. 1306..



		 Nm				
DW06	DCS 09	1.7	DWS 328-01	US 2004-T09P	FLAG T09P	–
DW08	DCS 12	3.9	DWS 331-12	US 2002-T15P	FLAG T15P/3,5	–
DW10	DCS 16	6.4	DWN 100612	US 5018-T20P	–	LK T20P
DW13	DCS 19	6.4	DWN 130612	US 6013-T20P	–	LK T20P

		
AT004a	CER WN.N 0804..	DCS 12C4
AT004b	CER WN.A 0804..	DCS 12C2



MWLN(RL) EXT

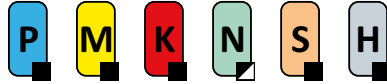

PRAMET

M

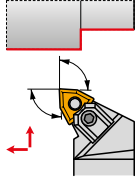

WN.. Uç için Pabuçlu 95° Açılı Dış Kater

Pabuçlu, 95° açılı Sağ/Sol dış kater. Negatif WN.. 08 uçlarla çap, alın, konik ve pah tornalamak için uygundur. 25x25'den 40x40mm'ye kadar mevcuttur. Gövde uzun takım ömrü için işlem görmüştür.

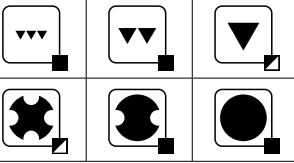
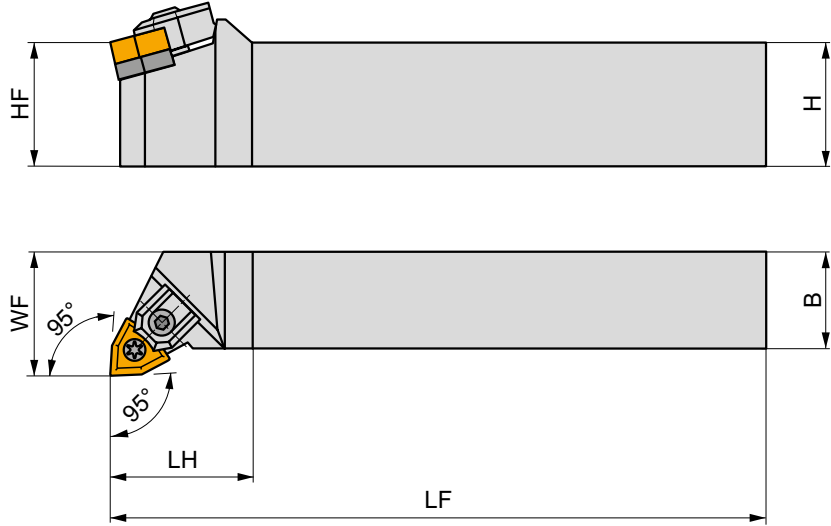

Product	H	B	HF	WF	LF	LH	LAMS	GAMO	kg	GI072	MW1	
	(mm)	(mm)	(mm)	(mm)	(mm)	(mm)	(°)	(°)				
R	MWLN 2525 M 08	25	25	25	32	150	32	-6	-6	0.73	GI072	MW1
	MWLN 3225 P 08	32	25	32	32	170	32	-6	-6	1.30	GI072	MW1
	MWLN 4040 R 08	40	40	40	50	200	32	-6	-6	2.50	GI072	MW1
L	MWLN 2525 M 08	25	25	25	32	150	32	-6	-6	0.70	GI072	MW1
	MWLN 3225 P 08	32	25	32	32	170	32	-6	-6	1.02	GI072	MW1
	MWLN 4040 R 08	40	40	40	50	200	32	-6	-6	2.50	GI072	MW1



GI072



WN.. 0804..



MW1



UE 05



5.0



WNW 080412



UC 51



HS 0408



HXK 3



PWLN(RL) EXT



PRAMET

P



WN.. Uç için Levveli 95° Açılı Dış Kater

Levveli, 95° açılı Sağ/Sol dış kater. Negatif WN.. 06 ve 08 uçlarla çap, alın, konik ve pah tornalamak için uygundur. 16x16'dan 32x25mm'ye kadar mevcuttur. Gövde uzun takım ömrü için işlem görmüştür.

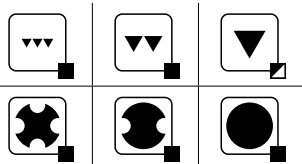
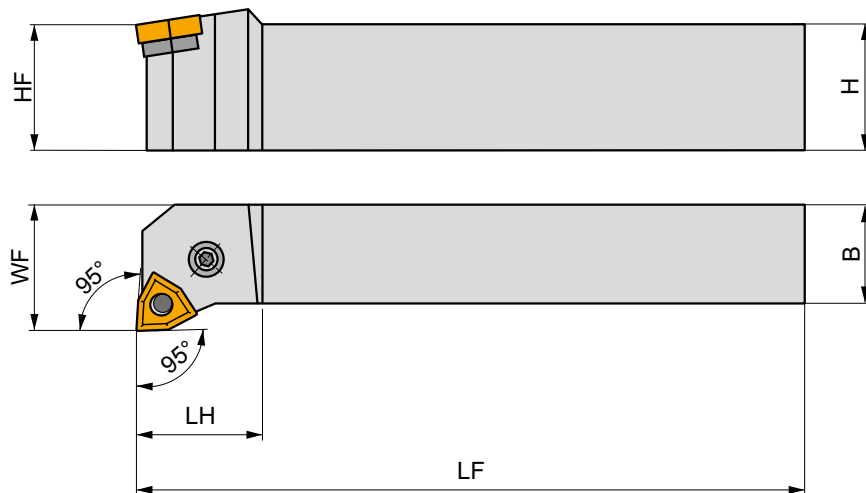
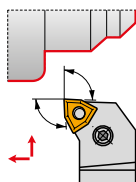

	Product	H	B	HF	WF	LF	LH	LAMS	GAMO	kg	G1028	PW11
		(mm)	(mm)	(mm)	(mm)	(mm)	(mm)	(°)	(°)			
R	PWLN R 1616 H 0604	16	16	16	20	100	20	-6	-6	0.23	G1028	PW11
	PWLN R 2020 K 0604	20	20	20	25	125	20	-6	-6	0.40	G1028	PW10
	PWLN R 2525 M 0604	25	25	25	32	150	20	-6	-6	0.78	G1028	PW10
	PWLN R 2020 K 08	20	20	20	25	125	22	-6	-6	0.42	G1072	PW22
	PWLN R 2525 M 08	25	25	25	32	150	22	-6	-6	0.73	G1072	PW20
	PWLN R 3225 P 08	32	25	32	32	170	22	-6	-6	1.05	G1072	PW20
L	PWLN L 1616 H 0604	16	16	16	20	100	20	-6	-6	0.21	G1028	PW11
	PWLN L 2020 K 0604	20	20	20	25	125	20	-6	-6	0.40	G1028	PW10
	PWLN L 2525 M 0604	25	25	25	32	150	20	-6	-6	0.75	G1028	PW10
	PWLN L 2020 K 08	20	20	20	25	125	22	-6	-6	0.40	G1072	PW22
	PWLN L 2525 M 08	25	25	25	32	150	22	-6	-6	0.74	G1072	PW20
	PWLN L 3225 P 08	32	25	32	32	170	22	-6	-6	1.05	G1072	PW20



G1028
G1072



WN.. 0604..
WN.. 0804..



PW10

WNU 060308

PU 01

US 34

5.0

M 6x0.75

19

NT 04

MT 04

HXX 3

PW11

WNU 060308

PU 01

US 46

5.0

M 6x0.75

13.2

NT 04

MT 04

HXX 3

PW20

WNU 080312

PU 02

US 35

6.0

M 8x1

22.5

NT 05

MT 05

HXX 4

PW22

WNU 080312

PU 02

US 42

6.0

M 8x1

21

NT 05

MT 05

HXX 4

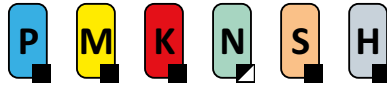
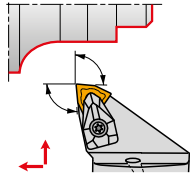
NEW
C.-DWLN(RL) EXT

PRAMET
D

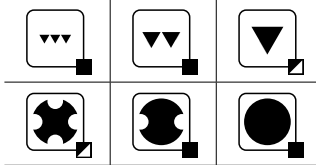
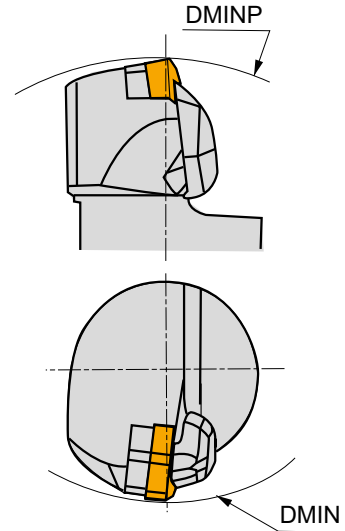
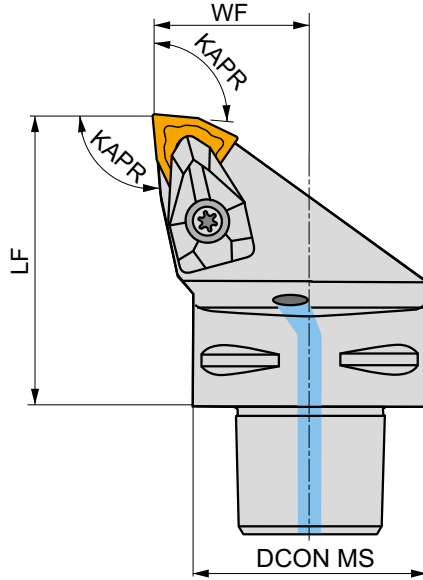
WN.. Uç için Çift Sıkmalı, 95° Açılı Hızlı Değişirme Dış Takımı

Çift sıkmalı, 95° açılı, içten su vermeli Sağ/Sol dış kater. Negatif WN.. 06 veya 08 uçlarla çap, alın, konik ve pah tornalamak için uygundur. C4 - C6 şaftlı mevcuttur. Tutucu uzun takım ömrü için işlem görmüştür.



Product	DCON MS (mm)	DMIN (mm)	DMINP (mm)	WF (mm)	LF (mm)	KAPR (°)	LAM S (°)	GAM O (°)	✓	kg	GI028	C-DW06	AT004	
R	C4-DWLN-27050-06	40	60	140	27	50	95	-6	-6	✓	0.42	GI028	C-DW06	-
	C4-DWLN-27050-08	40	110	140	27	50	95	-6	-6	✓	0.42	GI072	C-DW08-1	AT004
	C5-DWLN-35060-08	50	110	165	35	60	95	-6	-6	✓	0.74	GI072	C-DW08-2	AT004
L	C6-DWLN-45065-08	63	110	190	45	65	95	-6	-6	✓	1.34	GI072	C-DW08-2	AT004
	C4-DWLN-27050-06	40	60	140	27	50	95	-6	-6	✓	0.43	GI028	C-DW06	-
	C4-DWLN-27050-08	40	110	140	27	50	95	-6	-6	✓	0.42	GI072	C-DW08-1	AT004
C5-DWLN-35060-08	50	110	165	35	60	95	-6	-6	✓	0.76	GI072	C-DW08-2	AT004	
C6-DWLN-45065-08	63	110	190	45	65	95	-6	-6	✓	1.34	GI072	C-DW08-2	AT004	

 GI028
GI072

 WN.. 0604..
WN.. 0804..

C-DW06	DCS 09	1.7	DWS 328-01	US 2004-T09P	FLAG T09P	CN 034-01
C-DW08-1	DCS 12	3.9	DWS 331-12	US 2002-T15P	FLAG T15P/3,5	CN 034-01
C-DW08-2	DCS 12	3.9	DWS 331-12	US 2002-T15P	FLAG T15P/3,5	CN 045-01



AT004a	CER WN.N 0804..	DCS 12C4
AT004b	CER WN.A 0804..	DCS 12C2



DWLN(RL) INT



PRAMET

D



WN.. Uç için Çift Sıkmalı 95° Açılı Delik Kateri

Çift sıkmalı 95° Sağ/Sol içten su vermeli delik kateri. Negatif WN.. 06 veya 08 uçlarla minimum Ø32mm çap, konik ve pah tornalama için uygundur. Ø25-50mm şaft ölçüleri. Gövde uzun takım ömrü için işlem görmüştür.

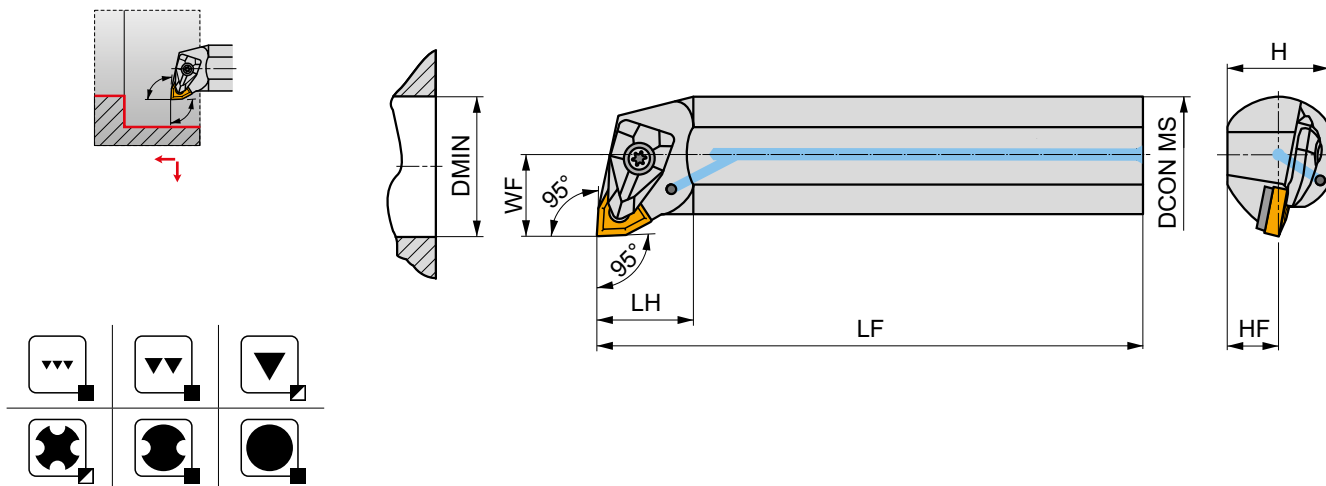

Product	DCON MS (mm)	DMIN (mm)	WF (mm)	H (mm)	HF (mm)	LF (mm)	LH (mm)	LAMS (°)	GAMO (°)					
R	A25T-DWLN R 06	25	32	17	23	11.5	300	31	-14	-6	✓	0.97	GI028	DW06
	A25T-DWLN R 08	25	33	17	23	11.5	300	31	-12	-6	✓	0.98	GI072	DWI08
	A32T-DWLN R 08	32	40	22	30	15	300	33	-10	-6	✓	1.71	GI072	DWI08
	A40T-DWLN R 08	40	50	27	37	18.5	300	36	-13	-6	✓	2.59	GI072	DW08
	A50U-DWLN R 08	50	63	35	47	23.5	350	39	-11	-6	✓	5.24	GI072	DW08
L	A25T-DWLN L 06	25	32	17	23	11.5	300	31	-14	-6	✓	0.97	GI028	DW06
	A25T-DWLN L 08	25	33	17	23	11.5	300	31	-12	-6	✓	0.98	GI072	DWI08
	A32T-DWLN L 08	32	40	22	30	15	300	33	-10	-6	✓	1.70	GI072	DWI08
	A40T-DWLN L 08	40	50	27	37	18.5	300	36	-13	-6	✓	2.59	GI072	DW08
	A50U-DWLN L 08	50	63	35	47	23.5	350	39	-11	-6	✓	5.25	GI072	DW08

GI028		WN.. 0604..	
GI072		WN.. 0804..	

DW06	DCS 09	1.7	DWS 328-01	US 2004-T09P	FLAG T09P
DW08	DCS 12	3.9	DWS 331-12	US 2002-T15P	FLAG T15P/3,5
DWI08	DCS 12	3.9	DWS 328-02	US 2002-T15P	FLAG T15P/3,5



PWLN(RL) INT

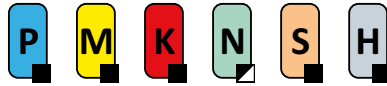

WN.. Uç için Levveli 95° Açılı Delik Kateri

Levveli 95° Sağ/Sol içten su vermeli delik kateri. Negatif WN.. 06 veya 08 uçlarla minimum Ø20mm çap, konik ve pah tornalama için uygundur. Ø16-60mm shaft ölçüleri. Gövde uzun takım ömrü için işlem görmüştür.

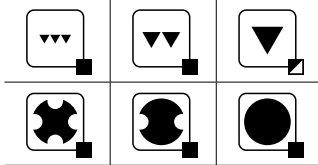
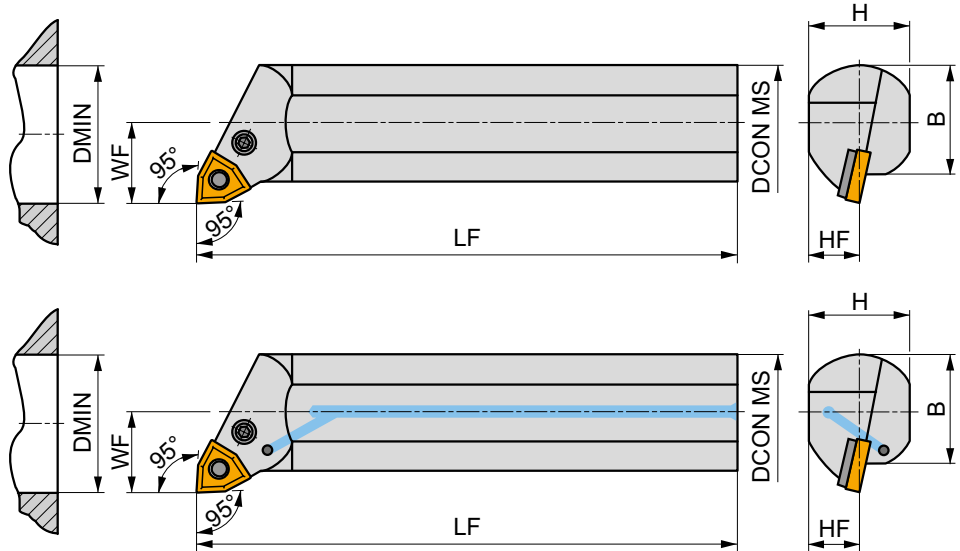
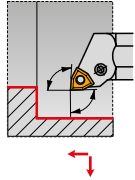

Product	DCON MS	DMIN	WF	H	B	LF	LAMS	GAMO				
	(mm)	(mm)	(mm)	(mm)	(mm)	(mm)	(°)	(°)				
R	A16M-PWLN R 0604	16	20	11	15	15	-13.5	-6	✓	0.22	G1028	PW09
	A20Q-PWLN R 0604	20	27	13	18	18	-13.5	-6	✓	0.36	G1028	PW09
	S25T-PWLN R 0604	25	32	17	23	23	-12	-6	-	1.10	G1028	PW11
	A32S-PWLN R 0604	32	40	22	30	30	-12	-6	✓	1.30	G1028	PW11
	A25R-PWLN R 08	25	32	17	23	23	-12	-6	✓	0.66	G1072	PW25
	S25T-PWLN R 08	25	32	17	23	23	-12	-6	-	1.10	G1072	PW25
	A32S-PWLN R 08	32	40	22	30	30	-12	-6	✓	1.46	G1072	PW21
	S32U-PWLN R 08	32	40	22	30	30	-12	-6	-	2.09	G1072	PW21
	A40T-PWLN R 08	40	50	27	38	38	-12	-6	✓	2.40	G1072	PW20
	A50U-PWLN R 08	50	63	35	47	48.5	-12	-6	✓	4.88	G1072	PW20
	A60V-PWLN R 08	60	80	43	57	58.5	-12	-6	✓	8.10	G1072	PW20
L	A16M-PWLN L 0604	16	20	11	15	15	-13.5	-6	✓	0.22	G1028	PW09
	A20Q-PWLN L 0604	20	27	13	18	18	-13.5	-6	✓	0.36	G1028	PW09
	S25T-PWLN L 0604	25	32	17	23	23	-12	-6	-	0.98	G1028	PW11
	A32S-PWLN L 0604	32	40	22	30	30	-12	-6	✓	1.28	G1028	PW11
	A25R-PWLN L 08	25	32	17	23	23	-12	-6	✓	0.75	G1072	PW25
	S25T-PWLN L 08	25	32	17	23	23	-12	-6	-	1.01	G1072	PW25
	A32S-PWLN L 08	32	40	22	30	30	-12	-6	✓	1.47	G1072	PW21
	S32U-PWLN L 08	32	40	22	30	30	-12	-6	-	2.08	G1072	PW21
	A40T-PWLN L 08	40	50	27	38	38	-12	-6	✓	2.90	G1072	PW20
	A50U-PWLN L 08	50	63	35	47	48.5	-12	-6	✓	4.88	G1072	PW20
	A60V-PWLN L 08	60	80	43	57	58.5	-12	-6	✓	8.70	G1072	PW20













G1028
G1072



WN.. 0604..
WN.. 0804..

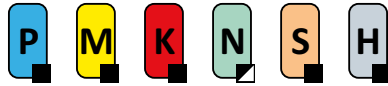

					 Nm					
PW09	–	PU 3611-A	PS 0512-A	2.0	M 5	12	–	–	–	HXX 2
PW11	WNU 060308	PU 01	US 46	5.0	M 6x0.75	13.2	NT 04	MT 04	–	HXX 3
PW20	WNU 080312	PU 02	US 35	6.0	M 8x1	22.5	NT 05	MT 05	–	HXX 4
PW21	WNU 080312	PU 02	US 41	6.0	M 8x1	17	NT 05	MT 05	–	HXX 4
PW25	–	PU 32	US 46	5.0	M 6x0.75	13.2	–	–	–	HXX 3

NEW
C.-DWLN(RL) INT

PRAMET
D

WN.. Uçlar için Çift Sıklımlı 95° Açılı PSC Hızlı Değişirme Delik Takımı

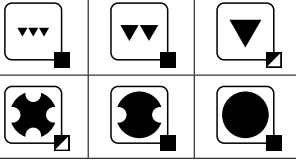
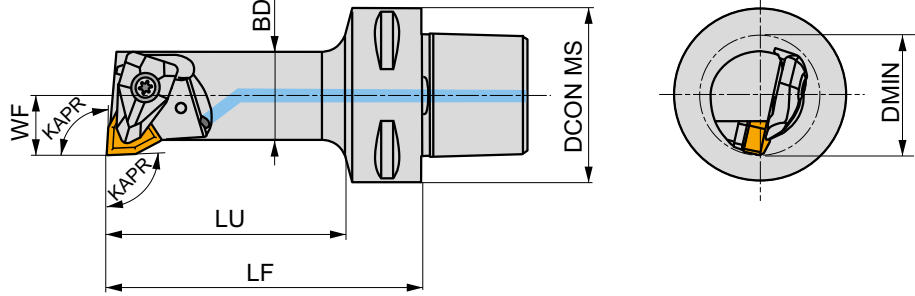
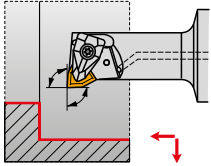
Çift sıklımlı 95° Sağ/Sol içten su vermeli delik kateri. Negatif WN.. 06 veya 08 uçlarla minimum Ø27mm çap, ve pah tornalama için uygundur. PSC C4 shaft ölçüleri. Gövde uzun takım ömrü için işlem görmüştür.



Product	DCON MS (mm)	DMIN (mm)	WF (mm)	LF (mm)	LU (mm)	BD (mm)	KAPR (°)	LAMS (°)	GAMO (°)					
R	C4-DWLN-13075-06	40	27	13	75	52	20	95	-17	-6	✓	0.42	GI028	DW06
	C4-DWLN-17090-08	40	33	17	90	68	25	95	-12	-6	✓	0.53	GI072	DWI08
L	C4-DWLN-13075-06	40	27	13	75	52	20	95	-17	-6	✓	0.42	GI028	DW06
	C4-DWLN-17090-08	40	33	17	90	68	25	95	-12	-6	✓	0.53	GI072	DWI08

 GI028
 GI072

 WN.. 0604..
 WN.. 0804..

 DW06
 DWI08

 DCS 09
 DCS 12

 1.7
 3.9

 DWS 328-01
 DWS 328-02

 US 2004-T09P
 US 2002-T15P

 FLAG T09P
 FLAG T15P/3,5

**KESME
VE KANAL AÇMA**





TORNALAMA – GENEL İÇERİK

6		İŞ PARÇASI MALZEME GRUPLARI (WMG) VE ISO 13399
10	ISO TORNALAMA	GENEL BİLGİLER
18		REHBER
57		POZİTİF KESİCİ UÇLAR
219		NEGATİF KESİCİ UÇLAR
386		DİLİMLEME VE KANAL AÇMA
482		DİŞ TORNALAMA
528		BROŞLAMA
536		GENEL TEKNİK BİLGİLER



KESME VE KANAL AÇMA UÇLARI – GENEL BAKIŞ SAYFASI

1 GL. D - GM

PRAMET

	CW	CWTOLL	CWTOLU	INSL
	[mm]	[mm]	[mm]	[mm]
200	2.00	-0.05	0.05	25.0
300	3.00	-0.05	0.05	25.0
400	4.00	-0.05	0.05	25.0
500	5.00	-0.05	0.05	25.0
600	6.00	-0.05	0.05	25.0

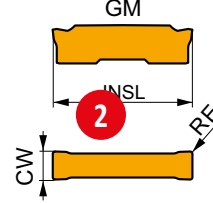

Kesme hızı (vc), ilerleme (f) ve kesme derinliği (ap) için uygunluk ve başlangıç değerleri. Daha ileri hesaplamalar için İşleme Hesaplayıcısı uygulamasına başvurun.

Product	RE	P			M			K			N			S			H		
		vc	f	ap	vc	f	ap	vc	f	ap	vc	f	ap	vc	f	ap			
	[mm]	[m/min]	[mm/rev]	[mm]	[m/min]	[mm/rev]	[mm]	[m/min]	[mm/rev]	[mm]	[m/min]	[mm/rev]	[mm]	[m/min]	[mm/rev]	[mm]			



10 GM geometri, kanal açma ve çap tornalama için, darbesizden darbeli kesime kadar uygun.

GL2-D200M02-GM	G8330	0.2	190	0.10	0.8	110	0.09	0.8	180	0.10	0.8	-	-	-	45	0.08	0.6	-	-	-
GL2-D300M02-GM	T7325	0.2	220	0.10	0.8	170	0.09	0.8	-	-	-	-	-	-	70	0.08	0.6	-	-	-
GL2-D400M02-GM	T7325	0.2	150	0.20	1.0	90	0.18	1.0	140	0.20	1.0	-	-	-	35	0.14	0.8	-	-	-
GL3-D300M04-GM	T7325	0.2	175	0.20	1.0	135	0.18	1.0	-	-	-	-	-	-	55	0.14	0.8	-	-	-
GL3-D300M04-GM	G8330	0.4	160	0.20	1.0	95	0.18	1.0	150	0.20	1.0	-	-	-	40	0.14	0.8	-	-	-
GL3-D300M04-GM	T7325	0.4	185	0.20	1.0	140	0.18	1.0	-	-	-	-	-	-	60	0.14	0.8	-	-	-
GL4-D400M04-GM	G8330	0.4	150	0.25	1.2	90	0.23	1.2	140	0.25	1.2	-	-	-	35	0.18	1.0	-	-	-
GL4-D400M04-GM	T7325	0.4	170	0.25	1.2	130	0.23	1.2	-	-	-	-	-	-	55	0.18	1.0	-	-	-
GL4-D400M08-GM	G8330	0.8	180	0.25	1.2	105	0.23	1.2	170	0.25	1.2	-	-	-	45	0.18	1.0	-	-	-
GL4-D400M08-GM	T7325	0.8	200	0.25	1.2	155	0.23	1.2	-	-	-	-	-	-	65	0.18	1.0	-	-	-
GL5-D500M08-GM	G8330	0.8	170	0.30	1.2	100	0.27	1.2	160	0.30	1.2	-	-	-	40	0.21	1.0	-	-	-
GL5-D500M08-GM	T7325	0.8	190	0.30	1.2	145	0.27	1.2	-	-	-	-	-	-	60	0.21	1.0	-	-	-
GL6-D600M08-GM	G8330	0.8	170	0.30	1.2	100	0.27	1.2	160	0.30	1.2	-	-	-	40	0.21	1.0	-	-	-

GL5-D500M08-GM:T7325

Sipariş verirken kesici uç özellik kodunu tam olarak belirtin!

Kalite

İki nokta üst üste
işaretini ekleyin

ISO kesici uç kodu



KESME VE KANAL AÇMA UÇLARI – GENEL BAKIŞ SAYFASI

Poz.	Açıklama	Poz.	Açıklama
1	Kesici ucun işareti	7	ISO kesici uç kodu
2	Kesici ucun şematik çizimi	8	Kalite
3	Kesici uç boyutları tablosu (mm)	9	Kesici uç yarıçapları (mm)
4	Temsili kesici ucun resmi	10	Geometri açıklaması
5	Ana Kesme kenarının profili	11	Kesici ucun uygulama alanı
6	Simgeler - spesifik özellikler ve kesme kenarı tipi		



KESME VE KANAL AÇMA TUTUCULARI – GENEL BAKIŞ SAYFASI

1 GG.(RL) INT



PRAMET

3 G



LCM. Uç için Delik Kanal Kateri

LCM. 0313 veya 0413 uçlar için Sağ/Sol delik kanal kateri. Minimum kanal açma çapı Ø16mm. Delik içi kanal açma ve çok yönlü tornalama için uygundur. Ø16-32mm shaft ölçülerinde bulunur. Gövde uzun takım ömrü için işlem görmüştür.

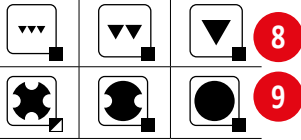
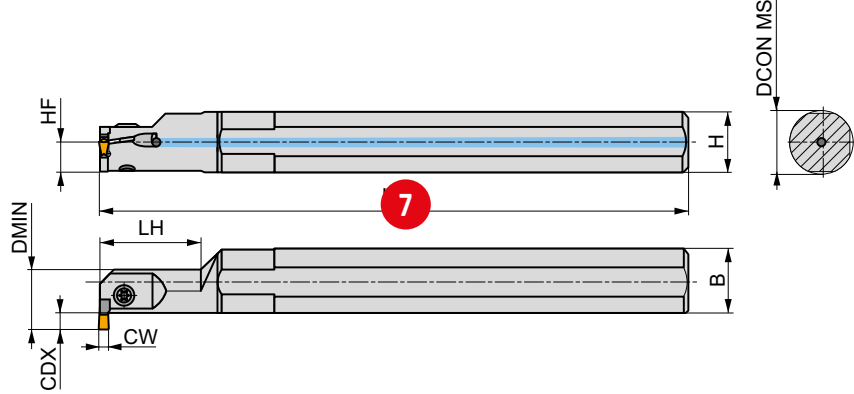
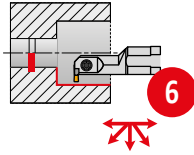

Product	DCON MS [mm]	HF [mm]	H [mm]	B [mm]	L _F [mm]	L _H [mm]	CW [mm]	CDX [mm]	DMIN [mm]		kg		
A16Q-GGER 0313	16	7.5	15	15.5	180	25	3.00	3	16	✓	0.26	GI143	GL06
A16Q-GGER 0313-04	16	7.5	15	15.5	180	25	3.00	3	16	✓	0.26	GI190	GL06
A20R-GGFR 0313	20	9	18	19	200	30	3.00	4.5	20	✓	0.36	GI143	GL06
A20R-GGFR 0313-04	20	9	18	19	200	30	3.00	4.5	20	✓	0.39	GI190	GL06
A25S-GGHR 0313	25	11.5	23	24	250	40	3.00	6.5	25	✓	0.78	GI143	GL06
A25S-GGHR 0413	25	11.5	23	24	250	40	4.00	6.5	25	✓	0.82	GI170	GL06
A32T-GGHL 0413	32	15	30	31	300	50	4.00	9.5	32	✓	1.59	GI170	GL06
A16Q-GGEL 0313	16	7.5	15	15.5	180	25	3.00	3	16	✓	0.29	GI143	GL06
A16Q-GGEL 0313-04	16	7.5	15	15.5	180	25	3.00	3	16	✓	0.28	GI190	GL06
A20R-GGFL 0313	20	9	18	19	200	30	3.00	4.5	20	✓	0.38	GI143	GL06
A20R-GGFL 0313-04	20	9	18	19	200	30	3.00	4.5	20	✓	0.38	GI190	GL06
A25S-GGHL 0313	25	11.5	23	24	250	40	3.00	6.5	25	✓	0.81	GI143	GL06
A25S-GGFL 0413	25	11.5	23	24	250	40	4.00	6.5	25	✓	0.82	GI170	GL06
A32T-GGHL 0413	32	15	30	31	300	50	4.00	9.5	32	✓	1.59	GI170	GL06



18



GI143

LCM. 0313..

GI170

LCM. 0413..

GI190

LCM. 0313.....04



GL06



SR 85011-T15P



5.0

19



M 5



9



FLAGT15P



KESME VE KANAL AÇMA TUTUCULARI – GENEL BAKIŞ SAYFASI

Poz.	Açıklama
1	Dilimleme ve kanal açma tutucusunun işareti
2	Malzeme grubu önerileri
3	Kesici ucun bağlama sistemi
4	Açıklayıcı resim ¹⁾
5	Takım açıklaması
6	İş parçası profili
7	Takımın şematik çizimi
8	Ulaşılabilir yüzey kalitesi
9	Kesim karakteri/çalışma koşulları
10	Ürün uygulamaları

Poz.	Açıklama
11	Takım tasarımı
12	Tutucunun kodu
13	Tutucunun ölçüleri [mm] ve açıları ²⁾ [°]
14	İçten kesme sıvısı beslemesi
15	Ağırlık [kg]
16	Uyumlu kesici uç grubu ³⁾
17	Yedek parça grubu ^{3),4)}
18	Uyumlu kesici uçlar
19	Yedek parçalar

¹⁾ Resimlerde birincil olarak sağ kesme yönlü (R) takım gösterilmiştir.

²⁾ GAMO = ortogonal açı (bkz. teknik bölüm)

LAMS = Ana kesici kenar eğim açısı (bkz. teknik bölüm)

³⁾ Uyumlu kesici uçlar, yedek parçalar ve özel aksesuarlar kodlama grubu sadece katalog amaçlıdır ve siparişler için kullanılamaz.

⁴⁾ Yedek parçaların ve özel aksesuarların simgeleri kolay anlaşılabilmesi için şematik olarak tasarlanmıştır. Bazı durumlarda vidalar Nm tork moment, vida boyu ve dış ölçüsü bilgileri ile tamamlanmıştır.



KESME VE KANAL AÇMA – SİMGELERE GENEL BAKIŞ

GENEL SİMGELER

	Birincil kullanım		Finiş işleme – çok iyi yüzey kalitesi		Stabil çalışma koşullarına uygun
	Olası kullanım		Orta talaş işleme – iyi yüzey kalitesi		Stabil olmayan çalışma koşullarına uygun
			Kaba talaş işleme – sınırlanmamış yüzey pürüzlülüğü		Çok dengesiz çalışma koşullarına uygun

TORNALAMA İŞLEMLERİ

	Kopya tornalama (çok yönlü işleme)		İç kanal açma		Sığ radyal oluk
	Derin ve geniş aksel oluk (takip eden genişlemeyle)		İç kanal açma (takip eden genişlemeyle)		Boru dilimleme
	Derin aksel oluk		Dilimleme		Geniş radyal oluk (takip eden genişlemeyle)
	Derin radyal oluk		Sığ ve geniş aksel oluk (takip eden genişlemeyle)		
	Alın kopya tornalama		Sığ aksel oluk		

ÖZELLİKLER

	İlk tercih		Üniversal geniş aralık seçeneği		Yuvarlatılmış kenar
	Büyük kullanma mesafesi		Ağır çalışma koşulları		Fazlı yuvarlatılmış kenar

DİĞER

	Vidanın başlama torku [Nm]		İçten kesme sıvısı beslemesi
--	----------------------------	--	------------------------------



KESME VE KANAL AÇMA UÇLARI – REHBER

GL. D **NEW**



406

LCMF 13



418

LCMF 16, LCMF 30



432

LCMF 20



453

LCMR 13

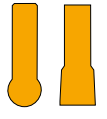

419

LCMR 16, LCMR 30

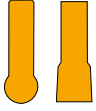

435

LFMX



456

LFUX



464

TN R EXT



475

TN R INT



475

TN ZZ EXT



476

TN ZZ INT

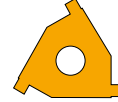

477

X 61 **NEW**



468

X 61 R **NEW**



469

X 61 R-1 **NEW**



473

X 61-1 **NEW**



472



KESME VE KANAL AÇMA GEOMETRİLERİ – REHBER

		İşlem tipi	uç ailesi seçimi	
			İlk tercih	İsteğe bağlı seçim
DIŞTAN		Kanal açma	GL. D NEW GM 406	LCMF16, LCMF30 F 432
		Dilimleme	GL. D NEW PM 407	LFMX M2 457
		Alına Kanal Açma	LCMF13 F 418	LCMF16, LCMF30 F 432
		Kopya profil işleme	GL. D NEW MM 406	LCMF16, LCMF30 MP 433
		Yaylı segmanlarda kanal açma	X61 NEW 469	TN ZZ EXT 476
İÇTEN		Kanal açma	LCMF13 F 418	
		Kopya profil işleme	LCMF13 MP 419	
		Yaylı segmanlarda kanal açma	X61 NEW 468	TN ZZ INT 477



KESME VE KANAL AÇMA KALİTELERİ – REHBER

Kalite Tanımlama	Uygulama Alanı	Uygulama	İlerleme	Kesme hızı	Olumsuz Çalışma Koşullarına Direnç	Kaplama	Renk	Altyapı	Kesme sıvısı avantajı	Kalite açıklaması
T9325	P15 - P35	■				MT-CVD	FGM	FGM	++	Teknolojik açıdan bakıldığında bu, olumsuz kesme koşullarında mekanik hasara karşı yüksek dirence sahip son derece çok yönlü bir kalitedir ve mükemmel aşınma direncini korur. Bu malzemenin doğru uygulanması için yüksek kesme hızları gerekir.
	M10 - M30	■								
	K15 - K35	■								
	S10 - S20	■								
T7325	P15 - P35	■				MT-CVD	FGM	FGM	+++	En üniversal tormalama kalitelerinden biridir. Paslanmaz çelik işleme için özel olarak tasarlanmıştır. Aşınma direnci ve performans güvenilirliği arasında optimum denge sunar. Tormalama işlemlerinde çok çeşitli uygulamalar için uygundur.
	M10 - M25	■								
	S10 - S25	■								
6640	P20 - P40	■				MT-CVD	H	H	+++	Özellikle kaba işleme operasyonlarında veya olumsuz kesme koşulları altında operasyonel güvenilirliğin öncelikli olduğu durumlarda kullanılabilen en tok tormalama malzemelerinden biridir. Düşük ila orta kesme hızlarında ve orta ila yüksek ilerleme hızlarında çalışan makineler için diğer bir ideal seçimdir.
	M20 - M35	■								
	K25 - K40	■								
T8330	P25 - P40	■				PVD	submicron H	submicron H	+++	Çok yönlü bir kesme malzemesi olan bu kalite tüm işlenmiş malzemelerin işlenmesinde kullanılır ve hemen her tür tormalama işleminde pratik olarak uygulanabilir. Başlıca avantajları yüksek operasyonel güvenilirlik ve çok iyi sürtünme özellikleridir; bu nedenle orta ve düşük kesme hızlarındaki uygulamalar için uygundur.
	M20 - M35	■								
	K20 - K40	■								
	N15 - N30	■								
	S15 - S25	■								
H15 - H25	■									
G8330	P25 - P40	■				PVD	submicron H	submicron H	+++	Kanal açma ve dilimleme uygulamaları için üniversal kesme kalitesi. Bu kalitenin karakteristik özellikleri olağanüstü güvenilirlik ve çok yönlülüktür. Çoğu iş parçası malzemesine ait işleme koşullarına uyacak şekilde geliştirilmiştir.
	M20 - M35	■								
	K20 - K40	■								
	S15 - S25	■								

Substrate

H	WC-Co bazlı alt yapı
submicron H	İnce tanecikli (< 1 µm) WC-Co bazlı alt yapı
FGM	İşlevsel kaliteli alt yapı

Kaplama

MT-CVD	Orta sıcaklıkta kimyasal kaplama
PVD	Düşük sıcaklıkta fiziksel kaplama

Kesme sıvısının avantajları

+++	Kesme sıvısı kullanımı esastır
++	Önemle tavsiye edilir

KESME VE KANAL AÇMA - DIŞ

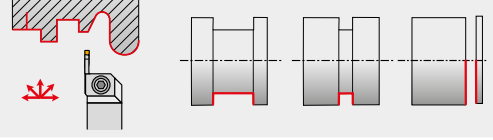

GLSF(RL) EXT **NEW**

	GL.D GL2 GL3 GL4 GL5 GL6
20x20 25x25	
410	406 - 408

GLSF(RL) EXT-G **NEW**

	GL.D GL2 GL3 GL4 GL5 GL6
20x20 25x25	
412	406 - 408

GLSF(RL) EXT-S **NEW**

	GL.D GL2 GL3 GL4
12x12 16x16	
413	406 - 408

GFK(RL) EXT

	LCMF 0220
16x16 25x25	
455	418 - 454

GFI(RL) EXT

	LCMF, LCMR 0316 0416 0516 0616 0830
16x16 32x25	
437	418 - 454

GFM(RL) EXT

	LCMF, LCMR 0316 0416 0516 0616 0830
20x20 32x25	
439	418 - 454

P61 (RL) EXT **NEW**

	X61
16x16 25x25	
470	468 - 469

XLCF(RL)

	LFUX 03 04 05 06
16x12 32x25	
465	464

XLCCN 25 BS + MS-EN

	LCMF, LCMR 0316 0416 0516 0616
25x25 32x25	
442, 443	418 - 454

XLCF(NRL) BS + MS-EN

	LFMX 1.50 1.60 2.00 2.20 3.10 4.10 5.10 6.35
12x12 32x25	
461, 463	456 - 458

GLS B + DU, D **NEW**

	GL.D GL2 GL3 GL4 GL5 GL6
20x20 32x29	
414, 415	406 - 409

XLCCN B + DU, D

	LCMF, LCMR 0316 0416 0516 0616
20x20 32x29	
440, 441	418 - 454

XLCFN B + DU, D





	LFMX 1.50 1.60 2.00 2.20 3.10 4.10 5.10 6.35
20x20 40x36	
459, 460	456 - 458



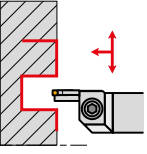

XLCFN B LFUX + DU, D



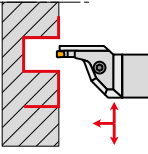

	LFUX 03 04 05 06
20x20 40x40	
466, 467	464



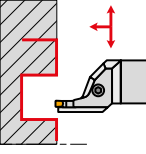

ALIN KANAL AÇMA





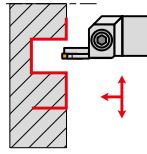



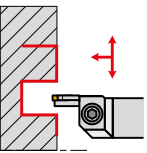

GFIL-L AXIAL	
LCMF, LCMR	
 0313 0316	
	
	17-30 140-230
	
422, 444	418 - 454



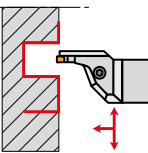

GFIL-R AXIAL	
LCMF, LCMR	
 0313 0316 0413 0416	
	
	17-30 140-230
	
423, 445	418 - 454



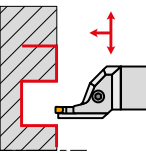

GFIR-L AXIAL	
LCMF, LCMR	
 0313 0316 0413 0416	
	
	17-30 140-230
	
424, 446	418 - 454



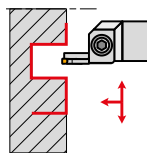

GFIR-R AXIAL	
LCMF, LCMR	
 0313 0316	
	
	17-30 140-230
	
425, 447	418 - 454



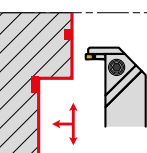

GFML-L AXIAL	
LCMF, LCMR	
 0413 0416	
	
	17-30 140-230
	
426, 448	418 - 454

GFML-R AXIAL	
LCMF, LCMR	
 0413 0416	
	
	17-30 140-230
	
427, 449	418 - 454

GFMR-L AXIAL	
LCMF, LCMR	
 0413 0416	
	
	17-30 140-230
	
428, 450	418 - 454

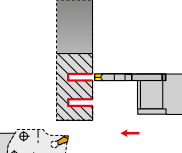
GFMR-R AXIAL	
LCMF, LCMR	
 0413 0416	
	
	17-30 140-230
	
429, 451	418 - 454

GGI(RL)-90 AXIAL	
LCMF, LCMR	
 0313 0316	
	
	17-30 110-170
	
430, 452	418 - 454

XLXFL BS AXIAL + MS-EN	
LFMX	
 3.10	
	
	60-85 150-280
	
462, 463	456 - 458

KANAL AÇMA - İÇ

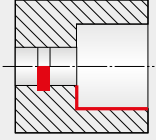

GG.(RL) INT	
	LCMF, LCMR
	0313 0413
421	418 - 454

P61 (RL) INT NEW	
	X61
471	468

P61S(RL)-1 INT NEW	
	X61-1
474	472



KESMEŞARETLERİ – KESME VE KANAL AÇMA KESİCİ UÇLARI

1	2	3	4	5	6	7	8
GL	3	D	300	G	02	L06	PM



1	2	3	4
Takım grubu	Yuva boyutu	Kenar sayısı	Kesme genişliği - CW

1, 2, 3, 4, 5, 6

GL

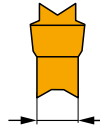

S	Tek kenarlı
D	İki kenarlı

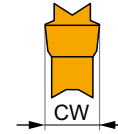

	CW
200	2.00
250	2.50
300	3.00
400	4.00
500	5.00
600	6.00

5	6	7	8
Kenar tasarımı	Köşe radyusu	Kesme kenarı açısı	Talaş kırıcı

G Taşlanmış

M Direkt preslenmiş

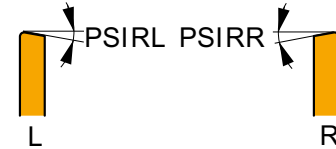
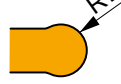
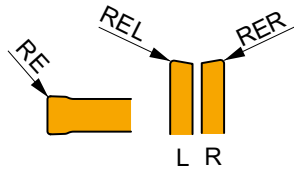

	RE, RER, REL (mm)
02	0.2
03	0.3
04	0.4
08	0.8

ROUND GEOMETRY

RE (mm)

MO RE = CW/2

	(°)
06	6
12	12

PM
PR
GM
MM



KESME VE KANAL AÇMA TUTUCULARI (DIŞ ÇAP TORNALAMA) – GL KODU İŞARETİ

1	2	3	4	5	6	7	8	9	10	11			
GL	3	-	S	2525	M	F	L	-	20	-	R	120	090

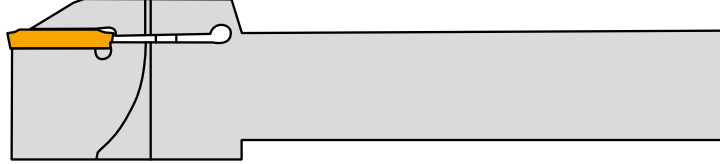

1	2	3	4
Takım grubu	Yuva boyutu	Şaft tipi	Şaft ölçüleri

1, 2, 3, 4, 5, 6

GL

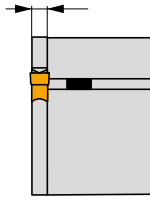

A	İçten soğutmalı çelik şaft
S	İçten soğutmasız çelik şaft

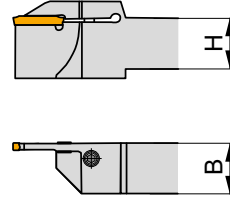

	H/B (mm)/(mm)
1212	12/12
1616	16/16
2020	20/20
2525	25/25

5	6	7	8
Şaft boyu - LF	Yanaşma açısı	Model (sağ/sol)	Maksimum kesme derinliği - CDX

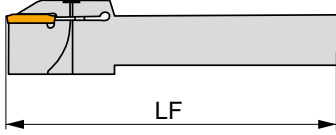

	LF (mm)
H	100
K	125
M	150
P	170

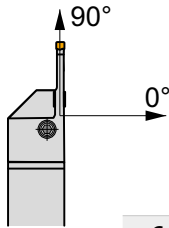

	(°)
G	0
F	90

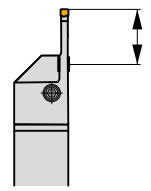
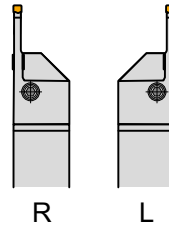

9	10	11
Takım kavis yönü	Maksimum çap	Minimum çap

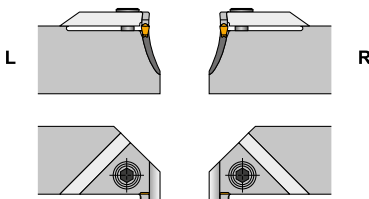

Eksenel tornalama için ek bilgi.

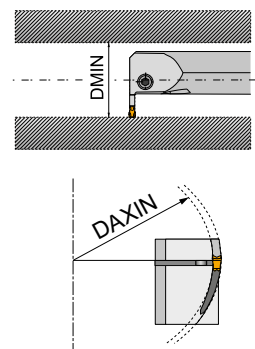
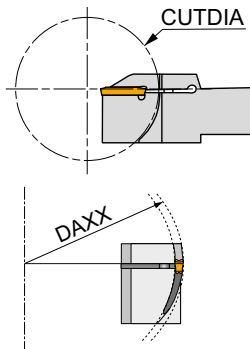



KESME VE KANAL AÇMA LAMALARI (DIŞ ÇAP TORNALAMA) – GL KODU İŞARETİ

1	2	3	4	5	6	
GL	3	-	S	32	M	B



1	2	3
Takım grubu	Yuva boyutu	Şaft tipi

1, 2, 3, 4, 5, 6

GL

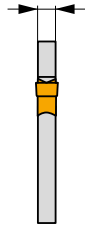

A	İçten soğutmalı çelik şaft
S	İçten soğutmasız çelik şaft

4	5	6
Şaft ölçüleri	Toplam lama uzunluğu - LF	Yanaşma açısı



	H (mm)
26	26
32	32

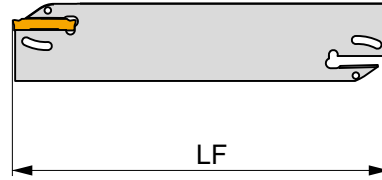

	LF (mm)	LF (")
K	125	5.000"
M	150	6.000"

B - lama

UÇLAR – ISO KODLAMA SİSTEMİ

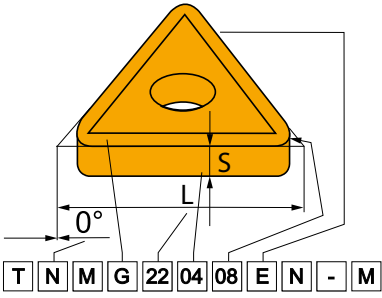

ISO

ANSI

1	2	3	4
T	N	U	N
T	N	M	G
1	2	3	4
T	N	U	
T	N	M	G

1				2				4														
Uç şekli				Serbest açı				Talaş kırıcı ve sıkma tipi														
H	O	P	R	A	B	C	D	N	R	F	A	M	G	W	T	Q	U	B	H	C	J	X
																						Özel
S	T	C	D	E	F	G	N	O														
								Özel														
E	M	V	W	L	A	B	K															

3 **3**

Toleranslar

	(mm)			(")		
	M (±)	S (±)	IC (±)	M (±)	S (±)	IC (±)
A	0.005	0.025	0.025	.0002"	.001"	.0010"
F	0.005	0.025	0.013	.0002"	.001"	.0005"
C	0.013	0.025	0.025	.0005"	.001"	.0010"
H	0.013	0.025	0.013	.0005"	.001"	.0005"
E	0.025	0.025	0.025	.0010"	.001"	.0010"
G	0.025	0.130	0.025	.0010"	.005"	.0010"
J	0.005	0.025	0.05 – 0.13	.0002"	.001"	.002 – 0.005"
K	0.013	0.025	0.05 – 0.13	.0005"	.001"	.002 – 0.005"
L	0.025	0.025	0.05 – 0.13	.0010"	.001"	.002 – 0.005"
M	0.08 – 0.18	0.130	0.05 – 0.13	.003 – 0.007"	.005"	.002 – 0.005"
N	0.08 – 0.18	0.025	0.05 – 0.13	.003 – 0.007"	.001"	.002 – 0.005"
U	0.05 – 0.38	0.130	0.05 – 0.13	.005 – 0.015"	.005"	.003 – 0.010"

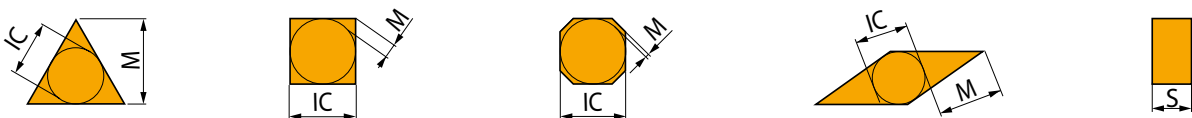

UÇLAR – ISO KODLAMA SİSTEMİ

5	6	7	8	9	10
22	04	08			
22	04	08	E	N	M
5	6	7	8	9	10
4	3	2			
4	3	2	E	N	M

5													5													6				7			
Kesici kenar uzunluğu																										Uç kalınlığı				Kesici kenar köşesi			
d = IC		H	O	P	S	T	C	D	E	M	V	W	R	K	S		S		RE														
(mm)	(in)														(mm)	(")	(mm)	(")	(mm)	(")	(mm)	(")											
3.97	5/32"				03	06		04			06	02																					
4.76	3/16"				04	08	04	05	04	04	08	L3																					
5.56	7/32"				05	09	05	06	05	05	09	03																					
6.35	1/4"	03	02	04	08	11	06	07	08	08	11	04	06																				
7.94	5/16"	04	03	05	07	13	08	09	06	07	13	05	07																				
9.525	3/8"	05	04	07	09	16	09	11	09	09	16	06	09	16																			
12.7	1/2"	07	05	09	12	22	12	15	13	12	22	08	12																				
15.875	5/8"	09	06	11	15	27	16	19	16	15	27	10	15																				
19.05	3/4"	11	07	13	19	33	19	23	19	19	33	13	19																				
25.40	1"	14	10	18	25	44	25	31	26	25	44	17	25																				
31.75	1 1/4"	18	13	23	31	54	32	38	32	31	54	21	31																				

ANSI																																																														
5			6				7																																																							
İç teğet çapı			Uç kalınlığı				Kesici kenar köşesi																																																							
Symbol			Symbol				Symbol																																																							
d = I.C.			S				RE																																																							
(mm)			(mm)				(mm)																																																							
(")			(")				(")																																																							
1	3.175	1/8"	1	1.588	1/16"	0	0	0"	0.2	0.099	1/256"	0.5	0.198	1/128"	1	0.397	1/64"	2	0.794	1/32"	3	1.191	3/64"	4	1.588	1/16"	5	1.984	5/64"	6	2.381	3/32"	7	2.778	7/64"	8	3.175	1/8"	9	3.572	3/8"	10	3.969	5/32"	11	4.366	1/2"	12	4.763	3/16"	13	5.160	1/4"	14	5.557	7/32"	15	5.954	1/2"	16	6.351	1/4"

8													8												
Kesme kenar tasarımı																									
F Keskin kesme kenarlı													E Yuvarlatılmış kesme kenarlı												
T ahlı kesme kenarlı													S Pahlı ve yuvarlatılmış kesme kenarlı												
K Çift pahlı kesme kenarlı													P Çift pahlı ve yuvarlatılmış kesme kenarlı												
9													9												
Kesme yönü																									
R Sağ kesme yönlü													N Sağ kesme yönlü												
L Sağ kesme yönlü													N Sağ kesme yönlü												
10													10												
Talaş kırıcı tipi																									



KESME VE KANAL AÇMA TAKIMLARI (DIŞ ÇAP TORNALAMA) – ISO KODU İŞARETİ

ISO	1	2	3	4	5	6	7	8	9	10	11
	G	F	I	L	25	25	M	0316	R	030	017
ANSI	1	2	3	4	5 & 6	7	8	9	10	11	
	G	F	I	L	16	D	0316	R	1.18	.670	

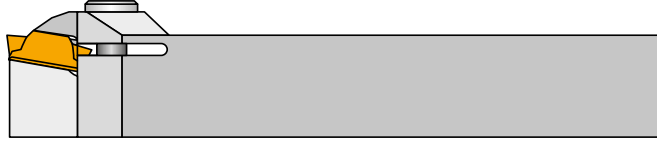

1	1	2	2	3	3	4	4
Sıkma tipi		Yanaşma açısı		Maksimum kesme derinliği – CDX		Model (sağ/sol) R/L	

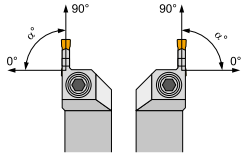
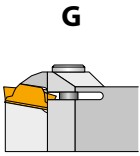

α°	
G = 0°	K = 75°
R = 15°	F = 90°
T = 30°	B = 105°
S = 45°	E = 120°
W = 60°	D = 135°



G = 2.0 × CW	N = 5.5 × CW
H = 2.5 × CW	O = 6.0 × CW
I = 3.0 × CW	P = 6.5 × CW
J = 3.5 × CW	Q = 7.0 × CW
K = 4.0 × CW	R = 7.5 × CW
L = 4.5 × CW	S = 8.0 × CW
M = 5.0 × CW	T = 8.5 × CW

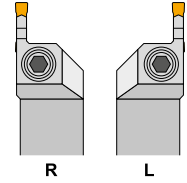

5	6	7	7	8	8		
Kesme kenar yüksekliği (mm)		Şaft genişliği (mm)		Şaft boyu		Uç genişliği	

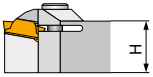

12 = 12 mm
16 = 16 mm
20 = 20 mm
etc.

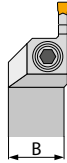

12 = 12 mm
16 = 16 mm
20 = 20 mm
etc.

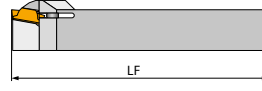

	LF (mm)		LF (")
H	100	A	4.000"
J	110	B	4.500"
K	125	C	5.000"
L	140	D	6.000"
M	150	E	7.000"
N	160	F	8.000"
P	170		
Q	180		
R	200		

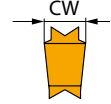

	CW (mm)	CW (")
02	2.0	.079"
03, 0313, 0316	3.0	.118"
04, 0413, 0416	4.0	.157"
05, 0516	5.0	.197"
06, 0616	6.0	.236"
08, 0830	8.0	.315"

5 & 6		
	B (")	H (")
05	5/16"	5/16"
06	3/8"	3/8"
08	1/2"	1/2"
10	5/8"	5/8"
12	3/4"	3/4"
16	1"	1"
85	1"	1 1/4"
86	1"	1 1/2"
20	1 1/4"	1 1/4"
24	1 1/2"	1 1/2"
32	2"	2"

Kare şaftlar için, genişlik ve yükseklik inç olarak 16'lık sayılardır. Dikdörtgen şaftlar için ilk basamak genişlik inç olarak 8'lik sayılardır ve ikinci basamak yükseklik inç olarak 4'lük sayılardır.

10	10
Maksimum çap - alın kanal açma	
Eksenel tornalama için ek bilgi.	

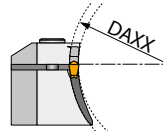

9	9
Takım kavis yönü	
Eksenel tornalama için ek bilgi.	

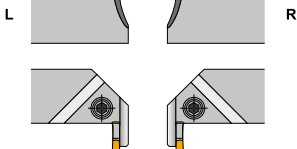

11	11
Minimum çap - alın kanal açma	
Eksenel tornalama için ek bilgi.	

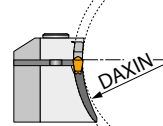



KESME VE KANAL AÇMA TAKIMLARI (İÇ ÇAP TORNALAMA) – ISO KODU İŞARETİ

ISO	1	2	3	–	4	5	6	7	8
	A	25	S	–	G	G	H	L	0313
ANSI	1	2	3	–	4	5	6	7	8
	A	16	S	–	G	G	H	L	0313



1	1	2	2	3	3					
Takım malzemesi		Şaft çapı		Şaft boyu						
S	Çelik şaft									
		DCON MS [mm]	DCON MS (")	LF [mm]	LF (")					
A	Soğutma suyu kanallı çelik şaft	12	12	M	150	6.000"	S	250	10.000"	
		16	16	10	170	6.250"	T	300	12.000"	
		20	20	12	180	7.250"	U	350	14.000"	
		25	25	16	200	8.000"	V	400	15.750"	
		32	32	20						
		40	40	24						

4	4	5	5	6	6	
Sıkma tipi		Yanaşma açısı		Maksimum kesme derinliği – CDX		
G					E = 1.0 x CW	J = 3.5 x CW
		$\alpha = 0^\circ$	$\alpha = 90^\circ$		F = 1.5 x CW	K = 4.0 x CW
					G = 2.0 x CW	L = 4.5 x CW
					H = 2.5 x CW	M = 5.0 x CW
					I = 3.0 x CW	N = 5.5 x CW
					X = Özel	

7	7	8	8
Model (sağ/sol) R/L		Uç genişliği	

R		L			
				CW [mm]	
				0313	3.0
				0413	4.0

NEW**GL. D - GM**

PRAMET

	CW	CWTOLL	CWTOLU	INSL
	(mm)	(mm)	(mm)	(mm)
200	2.00	-0.05	0.05	25.0
300	3.00	-0.05	0.05	25.0
400	4.00	-0.05	0.05	25.0
500	5.00	-0.05	0.05	25.0
600	6.00	-0.05	0.05	25.0

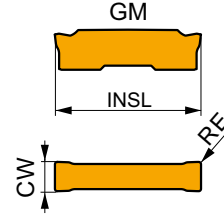

Kesme hızı (vc), ilerleme (f) ve kesme derinliği (ap) için uygunluk ve başlangıç değerleri. Daha ileri hesaplamalar için İşleme Hesaplayıcısı uygulamasına başvurun.

Product	RE	P			M			K			N			S			H		
		vc	f	ap	vc	f	ap	vc	f	ap	vc	f	ap	vc	f	ap	vc	f	ap
	(mm)	(m/min)	(mm/rev)	(mm)	(m/min)	(mm/rev)	(mm)	(m/min)	(mm/rev)	(mm)	(m/min)	(mm/rev)	(mm)	(m/min)	(mm/rev)	(mm)	(m/min)	(mm/rev)	(mm)

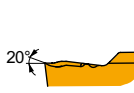

GM geometri, kanal açma ve çap tornalama için, darbesizden darbeli kesime kadar uygun.

GL2-D200M02-GM	G8330	0.2	■	190	0.10	0.8	■	110	0.09	0.8	■	180	0.10	0.8	–	–	–	■	45	0.08	0.6	–	–	–
	T7325	0.2	■	220	0.10	0.8	■	170	0.09	0.8	–	–	–	–	–	–	–	■	70	0.08	0.6	–	–	–
GL3-D300M02-GM	G8330	0.2	■	150	0.20	1.0	■	90	0.18	1.0	■	140	0.20	1.0	–	–	–	■	35	0.14	0.8	–	–	–
	T7325	0.2	■	175	0.20	1.0	■	135	0.18	1.0	–	–	–	–	–	–	–	■	55	0.14	0.8	–	–	–
GL3-D300M04-GM	G8330	0.4	■	160	0.20	1.0	■	95	0.18	1.0	■	150	0.20	1.0	–	–	–	■	40	0.14	0.8	–	–	–
	T7325	0.4	■	185	0.20	1.0	■	140	0.18	1.0	–	–	–	–	–	–	–	■	60	0.14	0.8	–	–	–
GL4-D400M04-GM	G8330	0.4	■	150	0.25	1.2	■	90	0.23	1.2	■	140	0.25	1.2	–	–	–	■	35	0.18	1.0	–	–	–
	T7325	0.4	■	170	0.25	1.2	■	130	0.23	1.2	–	–	–	–	–	–	–	■	55	0.18	1.0	–	–	–
GL4-D400M08-GM	G8330	0.8	■	180	0.25	1.2	■	105	0.23	1.2	■	170	0.25	1.2	–	–	–	■	45	0.18	1.0	–	–	–
	T7325	0.8	■	200	0.25	1.2	■	155	0.23	1.2	–	–	–	–	–	–	–	■	65	0.18	1.0	–	–	–
GL5-D500M08-GM	G8330	0.8	■	170	0.30	1.2	■	100	0.27	1.2	■	160	0.30	1.2	–	–	–	■	40	0.21	1.0	–	–	–
	T7325	0.8	■	190	0.30	1.2	■	145	0.27	1.2	–	–	–	–	–	–	–	■	60	0.21	1.0	–	–	–
GL6-D600M08-GM	G8330	0.8	■	170	0.30	1.2	■	100	0.27	1.2	■	160	0.30	1.2	–	–	–	■	40	0.21	1.0	–	–	–
	T7325	0.8	■	190	0.30	1.2	■	145	0.27	1.2	–	–	–	–	–	–	–	■	60	0.21	1.0	–	–	–

NEW**GL. D - MM**

PRAMET

	CW	CWTOLL	CWTOLU	INSL
	(mm)	(mm)	(mm)	(mm)
200	2.00	-0.05	0.05	25.0
300	3.00	-0.05	0.05	25.0
400	4.00	-0.05	0.05	25.0
500	5.00	-0.05	0.05	26.0
600	6.00	-0.05	0.05	26.0

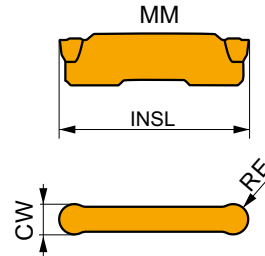

Kesme hızı (vc), ilerleme (f) ve kesme derinliği (ap) için uygunluk ve başlangıç değerleri. Daha ileri hesaplamalar için İşleme Hesaplayıcısı uygulamasına başvurun.

Product	RE	P			M			K			N			S			H		
		vc	f	ap	vc	f	ap	vc	f	ap	vc	f	ap	vc	f	ap	vc	f	ap
	(mm)	(m/min)	(mm/rev)	(mm)	(m/min)	(mm/rev)	(mm)	(m/min)	(mm/rev)	(mm)	(m/min)	(mm/rev)	(mm)	(m/min)	(mm/rev)	(mm)	(m/min)	(mm/rev)	(mm)

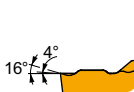

MM geometri, kopya profil ve çap tornalama için tam radyüs, darbesizden darbeli kesime kadar uygun.

GL2-D200MM0-MM	G8330	1.0	■	250	0.10	1.0	■	150	0.09	1.0	■	235	0.10	1.0	–	–	–	■	60	0.08	0.8	–	–	–
	T7325	1.0	■	285	0.10	1.0	■	220	0.09	1.0	–	–	–	–	–	–	–	■	90	0.08	0.8	–	–	–



Kesme hızı (vc), ilerleme (f) ve kesme derinliği (ap) için uygunluk ve başlangıç değerleri. Daha ileri hesaplamalar için İşleme Hesaplayıcısı uygulamasına başvurun.

Product	RE (mm)	P			M			K			N			S			H		
		vc (m/min)	f (mm/rev)	ap (mm)	vc (m/min)	f (mm/rev)	ap (mm)	vc (m/min)	f (mm/rev)	ap (mm)	vc (m/min)	f (mm/rev)	ap (mm)	vc (m/min)	f (mm/rev)	ap (mm)	vc (m/min)	f (mm/rev)	ap (mm)

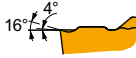

MM geometri, kopya profil ve çap tornalama için tam radyüs, darbesizden darbeli kesime kadar uygun.

GL3-D300MMO-MM	G8330	1.5	210	0.20	1.2	125	0.18	1.2	195	0.20	1.2	-	-	-	50	0.14	1.0	-	-	-
	T7325	1.5	240	0.20	1.2	185	0.18	1.2	-	-	-	-	-	-	75	0.14	1.0	-	-	-
GL4-D400MMO-MM	G8330	2.0	220	0.20	1.2	130	0.18	1.2	205	0.20	1.2	-	-	-	55	0.14	1.0	-	-	-
	T7325	2.0	250	0.20	1.2	195	0.18	1.2	-	-	-	-	-	-	80	0.14	1.0	-	-	-
GL5-D500MMO-MM	G8330	2.5	205	0.25	1.2	120	0.23	1.2	190	0.25	1.2	-	-	-	50	0.18	1.0	-	-	-
	T7325	2.5	235	0.25	1.2	180	0.23	1.2	-	-	-	-	-	-	75	0.18	1.0	-	-	-
GL6-D600MMO-MM	G8330	3.0	195	0.30	1.2	115	0.27	1.2	185	0.30	1.2	-	-	-	45	0.21	1.0	-	-	-
	T7325	3.0	220	0.30	1.2	170	0.27	1.2	-	-	-	-	-	-	70	0.21	1.0	-	-	-

NEW

GL. D - PM

PRAMET

	CW (mm)	CWTOLL (mm)	CWTOLU (mm)	INSL (mm)
200	2.00	-0.05	0.05	25.0
250	2.55	-0.05	0.05	25.0
300	3.00	-0.05	0.05	25.0
400	4.00	-0.05	0.05	25.0
500	5.00	-0.05	0.05	25.0
600	6.00	-0.05	0.05	25.0

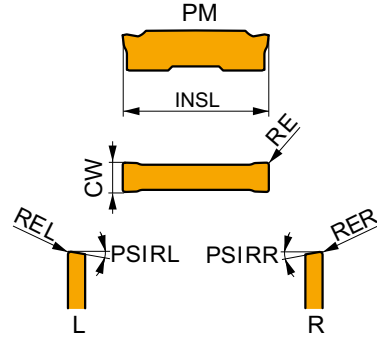

Kesme hızı (vc), ilerleme (f) için uygunluk ve başlangıç değerleri. Daha ileri hesaplamalar için İşleme Hesaplayıcısı uygulamasına başvurun.

Product	RE (mm)	P		M		K		N		S		H		PSIRR (°)	PSIRL (°)
		vc (m/min)	f (mm/rev)	vc (m/min)	f (mm/rev)	vc (m/min)	f (mm/rev)	vc (m/min)	f (mm/rev)	vc (m/min)	f (mm/rev)	vc (m/min)	f (mm/rev)		

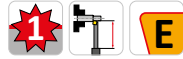
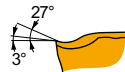

PM geometri, kesme ve kanal açma için ilk tercih, sürekli ve hafif darbeli kesim için uygun.

GL2-D200M02-PM	G8330	0.2	130	0.08	75	0.07	120	0.08	-	-	30	0.06	-	-	-
	T7325	0.2	150	0.08	115	0.07	-	-	-	-	45	0.06	-	-	-
GL3-D250G02-PM	G8330	0.2	130	0.10	75	0.09	120	0.10	-	-	30	0.07	-	-	-
	T7325	0.2	150	0.10	115	0.09	-	-	-	-	45	0.07	-	-	-
GL4-D400M02-PM	G8330	0.2	130	0.12	75	0.11	120	0.12	-	-	30	0.10	-	-	-
	T7325	0.2	150	0.12	115	0.11	-	-	-	-	45	0.10	-	-	-
GL5-D500M03-PM	G8330	0.3	130	0.15	75	0.14	120	0.15	-	-	30	0.12	-	-	-
GL6-D600M03-PM	G8330	0.3	130	0.15	75	0.14	120	0.15	-	-	30	0.12	-	-	-

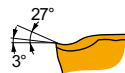

R-PM sağ kesme yönlü geometri, kesme için ilk tercih, darbesizden hafif darbeli kesime kadar uygun.

GL2-D200G02R06-PM	G8330	0.2	130	0.08	75	0.07	120	0.08	-	-	30	0.06	-	-	6
	T7325	0.2	150	0.08	115	0.07	-	-	-	-	45	0.06	-	-	6
GL2-D200G02R12-PM	G8330	0.2	130	0.08	75	0.07	120	0.08	-	-	30	0.06	-	-	12
	T7325	0.2	150	0.08	115	0.07	-	-	-	-	45	0.06	-	-	12
GL3-D300G02R06-PM	G8330	0.2	130	0.10	75	0.09	120	0.10	-	-	30	0.07	-	-	6
	T7325	0.2	150	0.10	115	0.09	-	-	-	-	45	0.07	-	-	6
GL3-D300G02R12-PM	G8330	0.2	130	0.10	75	0.09	120	0.10	-	-	30	0.07	-	-	12
	T7325	0.2	150	0.10	115	0.09	-	-	-	-	45	0.07	-	-	12
GL4-D400G02R06-PM	G8330	0.2	130	0.12	75	0.11	120	0.12	-	-	30	0.10	-	-	6
	T7325	0.2	150	0.12	115	0.11	-	-	-	-	45	0.10	-	-	6
GL4-D400G02R12-PM	G8330	0.2	130	0.12	75	0.11	120	0.12	-	-	30	0.10	-	-	12



Kesme hızı (vc), ilerleme (f) için uygunluk ve başlangıç değerleri. Daha ileri hesaplamalar için İşleme Hesaplayıcısı uygulamasına başvurun.

Product	RE (mm)	P		M		K		N		S		H		PSIRR (°)	PSIRL (°)
		vc (m/min)	f (mm/rev)	vc (m/min)	f (mm/rev)	vc (m/min)	f (mm/rev)	vc (m/min)	f (mm/rev)	vc (m/min)	f (mm/rev)	vc (m/min)	f (mm/rev)		

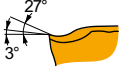

L-PM sol kesme yönlü geometri, kesme için ilk tercih, darbesizden hafif darbeleri kesime kadar uygun.

GL2-D200G02L06-PM	G8330	0.2	■	130	0.08	■	75	0.07	■	120	0.08	—	—	■	30	0.06	—	—	—	—	6
	T7325	0.2	■	150	0.08	■	115	0.07	—	—	—	—	—	—	■	45	0.06	—	—	—	—
GL2-D200G02L12-PM	G8330	0.2	■	130	0.08	■	75	0.07	■	120	0.08	—	—	■	30	0.06	—	—	—	—	12
	G8330	0.2	■	130	0.10	■	75	0.09	■	120	0.10	—	—	■	30	0.07	—	—	—	—	6
GL3-D300G02L06-PM	T7325	0.2	■	150	0.10	■	115	0.09	—	—	—	—	—	■	45	0.07	—	—	—	—	6
	G8330	0.2	■	130	0.10	■	75	0.09	■	120	0.10	—	—	■	30	0.07	—	—	—	—	12
GL3-D300G02L12-PM	G8330	0.2	■	130	0.12	■	75	0.11	■	120	0.12	—	—	■	30	0.10	—	—	—	—	6
GL4-D400G02L06-PM	T7325	0.2	■	150	0.12	■	115	0.11	—	—	—	—	—	■	45	0.10	—	—	—	—	6
	G8330	0.2	■	130	0.12	■	75	0.11	■	120	0.12	—	—	■	30	0.10	—	—	—	—	12

NEW

GL. D - PR

PRAMET

	CW (mm)	CWTOLL (mm)	CWTOLU (mm)	INSL (mm)
200	2.00	-0.05	0.05	25.0
300	3.00	-0.05	0.05	25.0
400	4.00	-0.05	0.05	25.0
500	5.00	-0.05	0.05	25.0
600	6.00	-0.05	0.05	25.0

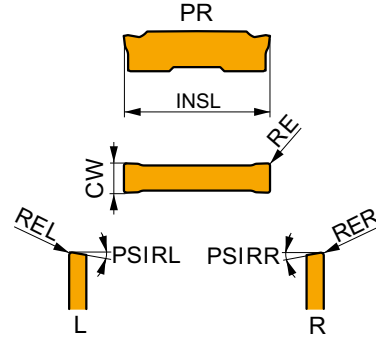

Kesme hızı (vc), ilerleme (f) için uygunluk ve başlangıç değerleri. Daha ileri hesaplamalar için İşleme Hesaplayıcısı uygulamasına başvurun.

Product	RE (mm)	P		M		K		N		S		H		PSIRR (°)	PSIRL (°)
		vc (m/min)	f (mm/rev)	vc (m/min)	f (mm/rev)	vc (m/min)	f (mm/rev)	vc (m/min)	f (mm/rev)	vc (m/min)	f (mm/rev)	vc (m/min)	f (mm/rev)		

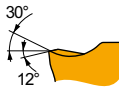

PM geometri, kesme ve kanal açma için ilk tercih, sürekli ve hafif darbeleri kesime kadar uygun.

GL2-D200M02-PR	G8330	0.2	■	130	0.10	■	75	0.09	■	120	0.10	—	—	—	—	—	—	—	—	—	—
	T7325	0.2	■	150	0.10	■	115	0.09	—	—	—	—	—	—	—	—	—	—	—	—	—
GL3-D300M02-PR	G8330	0.2	■	130	0.12	■	75	0.11	■	120	0.12	—	—	—	—	—	—	—	—	—	—
	T7325	0.2	■	150	0.12	■	115	0.11	—	—	—	—	—	—	—	—	—	—	—	—	—
GL4-D400M02-PR	G8330	0.2	■	130	0.15	■	75	0.14	■	120	0.15	—	—	—	—	—	—	—	—	—	—
	T7325	0.2	■	150	0.15	■	115	0.14	—	—	—	—	—	—	—	—	—	—	—	—	—
GL5-D500M04-PR	G8330	0.4	■	130	0.18	■	75	0.16	■	120	0.18	—	—	—	—	—	—	—	—	—	—
GL6-D600M04-PR	G8330	0.4	■	130	0.18	■	75	0.16	■	120	0.18	—	—	—	—	—	—	—	—	—	—

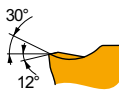

R-PR sağ kesme yönlü geometri, kesme için ilk tercih, darbesizden hafif darbeleri kesime kadar uygun.

GL2-D200G02R06-PR	G8330	0.2	■	130	0.10	■	75	0.09	■	120	0.10	—	—	—	—	—	—	—	—	6	—
GL2-D200G02R12-PR	G8330	0.2	■	130	0.10	■	75	0.09	■	120	0.10	—	—	—	—	—	—	—	—	12	—
GL3-D300G02R06-PR	G8330	0.2	■	130	0.12	■	75	0.11	■	120	0.12	—	—	—	—	—	—	—	—	6	—
GL3-D300G02R12-PR	G8330	0.2	■	130	0.12	■	75	0.11	■	120	0.12	—	—	—	—	—	—	—	—	12	—
GL4-D400G02R06-PR	G8330	0.2	■	130	0.15	■	75	0.14	■	120	0.15	—	—	—	—	—	—	—	—	6	—
GL4-D400G02R12-PR	G8330	0.2	■	130	0.15	■	75	0.14	■	120	0.15	—	—	—	—	—	—	—	—	12	—



Kesme hızı (vc), ilerleme (f) için uygunluk ve başlangıç değerleri. Daha ileri hesaplamalar için İşleme Hesaplayıcısı uygulamasına başvurun.

Product	RE (mm)	P		M		K		N		S		H		PSIRR (°)	PSIRL (°)
		vc (m/min)	f (mm/rev)	vc (m/min)	f (mm/rev)	vc (m/min)	f (mm/rev)	vc (m/min)	f (mm/rev)	vc (m/min)	f (mm/rev)	vc (m/min)	f (mm/rev)		

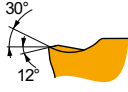

L-PR sol kesme yönlü geometri, kesme için ilk tercih, darbesizden hafif darbeli kesime kadar uygun.

GL2-D200G02L06-PR	G8330	0.2	■	130	0.10	■	75	0.09	■	120	0.10	—	—	—	—	6
GL2-D200G02L12-PR	G8330	0.2	■	130	0.10	■	75	0.09	■	120	0.10	—	—	—	—	12
GL3-D300G02L06-PR	G8330	0.2	■	130	0.12	■	75	0.11	■	120	0.12	—	—	—	—	6
GL3-D300G02L12-PR	G8330	0.2	■	130	0.12	■	75	0.11	■	120	0.12	—	—	—	—	12
GL4-D400G02L06-PR	G8330	0.2	■	130	0.15	■	75	0.14	■	120	0.15	—	—	—	—	6
GL4-D400G02L12-PR	G8330	0.2	■	130	0.15	■	75	0.14	■	120	0.15	—	—	—	—	12

NEW**GLSF(RL) EXT**

PRAMET

G**GL Uç için V-Kanal Sıkmalı Dış Kesme ve Kanal Kateri**

Çift taraflı GL 2, 3, 4, 5 veya 6 uçlar için Sağ/Sol radyal dış kanal kateri. 32mm derinliğe kadar radyal kanal açma ve kesme uygulamaları için uygundur. 20x20 ve 25x25 shaft ölçülerinde bulunur. Uzun takım ömrü ve düşük titreşim için güçlendirilmiş gövde.

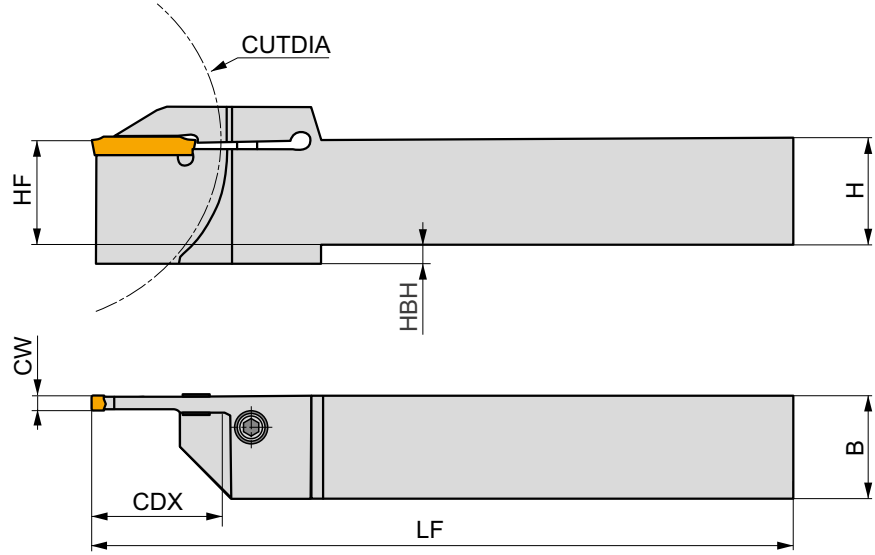
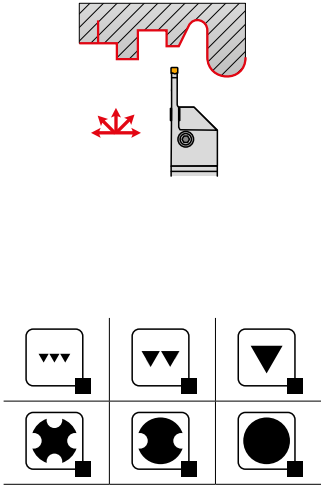

Product	HF	HBH	H	B	LF	CW	CDX	CUTDIA	kg	G	H
	(mm)	(mm)	(mm)	(mm)	(mm)	(mm)	(mm)	(mm)			
R GL2-S2020KFR-20-80	20	-	20	20	125	2.00	20	80	0.38	GI334	GL11
GL2-S2020KFR-24-80	20	5	20	20	125	2.00	24	80	0.36	GI334	GL11
GL2-S2525MFR-20-80	25	-	25	25	150	2.00	20	80	0.68	GI334	GL11
GL2-S2525MFR-24-80	25	-	25	25	150	2.00	24	80	0.64	GI334	GL11
GL3-S2020KFR-20-80	20	-	20	20	125	3.00	20	80	0.38	GI335	GL11
GL3-S2020KFR-24-80	20	5	20	20	125	3.00	24	80	0.36	GI335	GL11
GL3-S2525MFR-20-80	25	-	25	25	150	3.00	20	80	0.68	GI335	GL11
GL3-S2525MFR-24-80	25	-	25	25	150	3.00	24	80	0.65	GI335	GL11
GL3-S2525PFR-32-80	25	5	25	25	170	3.00	32	80	0.72	GI335	GL11
L GL4-S2020KFR-20-80	20	-	20	20	125	4.00	20	80	0.38	GI336	GL11
GL4-S2020KFR-24-80	20	5	20	20	125	4.00	24	80	0.37	GI336	GL11
GL4-S2525MFR-20-80	25	-	25	25	150	4.00	20	80	0.68	GI336	GL11
GL4-S2525MFR-24-80	25	-	25	25	150	4.00	24	80	0.65	GI336	GL11
GL4-S2525PFR-32-80	25	5	25	25	170	4.00	32	80	0.78	GI336	GL11
GL5-S2020KFR-20-80	20	-	20	20	125	5.00	20	80	0.38	GI337	GL11
GL5-S2525MFR-20-80	25	-	25	25	150	5.00	20	80	0.68	GI337	GL11
GL5-S2525PFR-32-100	25	5	25	25	170	5.00	32	100	0.75	GI337	GL11
GL6-S2020KFR-20-80	20	-	20	20	125	6.00	20	80	0.39	GI338	GL11
GL6-S2525MFR-20-80	25	-	25	25	150	6.00	20	80	0.68	GI338	GL11
GL6-S2525PFR-32-100	25	5	25	25	170	6.00	32	100	0.75	GI338	GL11
L GL2-S2020KFL-20-80	20	-	20	20	125	2.00	20	80	0.38	GI334	GL11
GL2-S2020KFL-24-80	20	5	20	20	125	2.00	24	80	0.36	GI334	GL11
GL2-S2525MFL-20-80	25	-	25	25	150	2.00	20	80	0.70	GI334	GL11
GL2-S2525MFL-24-80	25	-	25	25	150	2.00	24	80	0.64	GI334	GL11
GL3-S2020KFL-20-80	20	-	20	20	125	3.00	20	80	0.38	GI335	GL11
GL3-S2020KFL-24-80	20	5	20	20	125	3.00	24	80	0.36	GI335	GL11
GL3-S2525MFL-20-80	25	-	25	25	150	3.00	20	80	0.68	GI335	GL11



Product	HF	HBH	H	B	LF	CW	CDX	CUTDIA	kg		
	(mm)	(mm)	(mm)	(mm)	(mm)	(mm)	(mm)	(mm)			
GL3-S2525MFL-24-80	25	–	25	25	150	3.00	24	80	0.65	GI335	GL11
GL3-S2525PFL-32-80	25	5	25	25	170	3.00	32	80	0.78	GI335	GL11
GL4-S2020KFL-20-80	20	–	20	20	125	4.00	20	80	0.38	GI336	GL11
GL4-S2020KFL-24-80	20	5	20	20	125	4.00	24	80	0.37	GI336	GL11
GL4-S2525MFL-20-80	25	–	25	25	150	4.00	20	80	0.68	GI336	GL11
GL4-S2525MFL-24-80	25	–	25	25	150	4.00	24	80	0.65	GI336	GL11
GL4-S2525PFL-32-80	25	5	25	25	170	4.00	32	80	0.72	GI336	GL11
GL5-S2020KFL-20-80	20	–	20	20	125	5.00	20	80	0.38	GI337	GL11
GL5-S2525MFL-20-80	25	–	25	25	150	5.00	20	80	0.71	GI337	GL11
GL5-S2525PFL-32-100	25	5	25	25	170	5.00	32	100	0.75	GI337	GL11
GL6-S2020KFL-20-80	20	–	20	20	125	6.00	20	80	0.39	GI338	GL11
GL6-S2525MFL-20-80	25	–	25	25	150	6.00	20	80	0.71	GI338	GL11
GL6-S2525PFL-32-100	25	5	25	25	170	6.00	32	100	0.75	GI338	GL11

L

GI334
GI335
GI336
GI337
GI338

GL2..
GL3..
GL4..
GL5..
GL6..



GL11

US 5018-T20P

5.0

M 5

18.2

LK T20P

İşlenmiş çap için kesme derinlikleri için sayfa 416.

NEW**GLSF(RL) EXT-G**

PRAMET

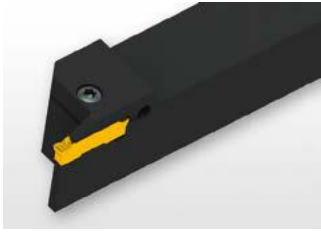
G**GL Uç için V-Kanal Sıkmalı Dış Kanal Kateri**

Çift taraflı GL 2, 3, 4, 5 veya 6 uçlar için Sağ/Sol radyal dış kanal kateri. 12mm derinliğe kadar radyal kanal açma, tornalama ve profil işleme için uygundur. 20x20 ve 25x25 shaft ölçülerinde bulunur. Uzun takım ömrü ve düşük titreşim için güçlendirilmiş gövde.

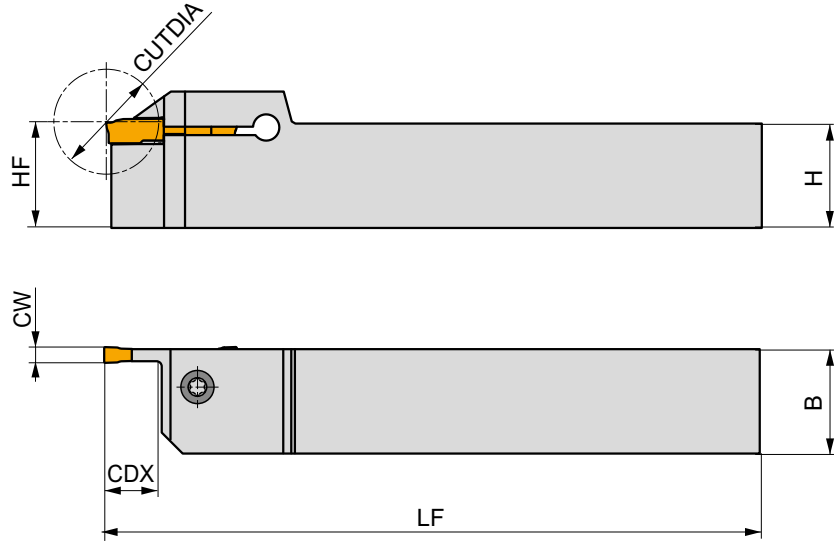
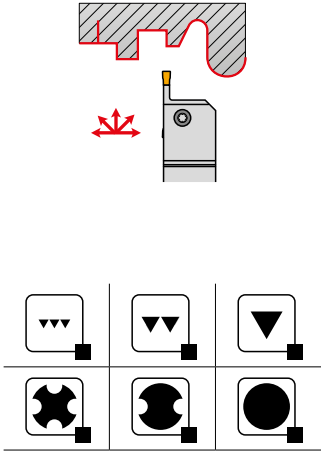

	Product	≡	H	B	L	CW	CDX	CUTDIA	kg			
		(mm)	(mm)	(mm)	(mm)	(mm)	(mm)	(mm)				
R	GL2-S2020KFR-10	20	20	20	125	2.00	10	20	0.38	G1334	GL11	
	GL2-S2525MFR-10	25	25	25	150	2.00	10	20	0.69	G1334	GL11	
	GL3-S2020KFR-10	20	20	20	125	3.00	10	20	0.36	G1335	GL11	
	GL3-S2525MFR-10	25	25	25	150	3.00	10	20	0.69	G1335	GL11	
	GL4-S2020KFR-12	20	20	20	125	4.00	12	24	0.37	G1336	GL11	
	GL4-S2525MFR-12	25	25	25	150	4.00	12	24	0.69	G1336	GL11	
	GL5-S2020KFR-12	20	20	20	125	5.00	12	24	0.36	G1337	GL11	
	GL5-S2525MFR-12	25	25	25	150	5.00	12	24	0.70	G1337	GL11	
	GL6-S2020KFR-12	20	20	20	125	6.00	12	24	0.36	G1338	GL11	
	GL6-S2525MFR-12	25	25	25	150	6.00	12	24	0.68	G1338	GL11	
	L	GL2-S2020KFL-10	20	20	20	125	2.00	10	20	0.37	G1334	GL11
		GL2-S2525MFL-10	25	25	25	150	2.00	10	20	0.70	G1334	GL11
GL3-S2020KFL-10		20	20	20	125	3.00	10	20	0.36	G1335	GL11	
GL3-S2525MFL-10		25	25	25	150	3.00	10	20	0.70	G1335	GL11	
GL4-S2020KFL-12		20	20	20	125	4.00	12	24	0.37	G1336	GL11	
GL4-S2525MFL-12		25	25	25	150	4.00	12	24	0.69	G1336	GL11	
GL5-S2020KFL-12		20	20	20	125	5.00	12	24	0.36	G1337	GL11	
GL5-S2525MFL-12		25	25	25	150	5.00	12	24	0.69	G1337	GL11	
GL6-S2020KFL-12		20	20	20	125	6.00	12	24	0.36	G1338	GL11	
GL6-S2525MFL-12		25	25	25	150	6.00	12	24	0.68	G1338	GL11	

G1334		GL2..
G1335		GL3..
G1336		GL4..
G1337		GL5..
G1338		GL6..

GL11	US 5018-T20P	5.0	M 5	18.2	LKT20P

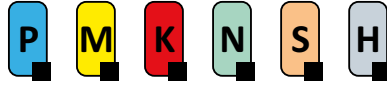
NEW**GLSF(RL) EXT-S**

PRAMET

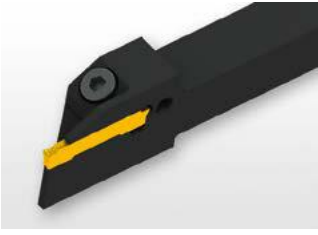
G**GL Uç için V-Kanal Sıkmalı Dış Kesme ve Kanal Kayar Otomat Kateri**

GL 2, 3, 4 veya 5 uçlar için Sağ/Sol radyal dış kayar otomat kateri. 16mm derinliğe kadar radyal kanal açma, kesme ve profil işleme için uygundur. 12x12 veya 16x16 şaft ölçülerinde bulunur. Uzun takım ömrü ve düşük titreşim için güçlendirilmiş gövde. Kolay ulaşım için tasarlanmıştır.

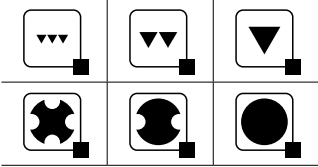
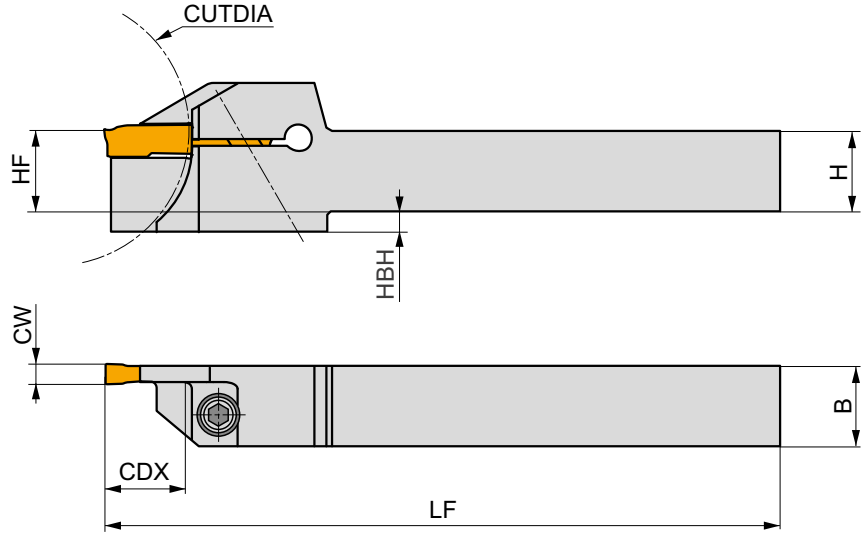
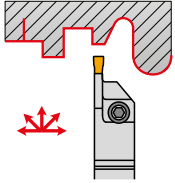

Product	HF	HBH	H	B	LF	CW	CDX	CUTDIA	kg			
	(mm)	(mm)	(mm)	(mm)	(mm)	(mm)	(mm)	(mm)				
R	GL2-S1212HFR-12-40	12	3	12	12	100	2.00	12	40	0.11	GI334	GL13
	GL2-S1616KFR-16-45	16	3	16	16	125	2.00	16	45	0.23	GI334	GL12
	GL3-S1212HFR-12-40	12	3	12	12	100	3.00	12	40	0.11	GI335	GL13
	GL3-S1616KFR-16-45	16	3	16	16	125	3.00	16	45	0.23	GI335	GL12
	GL4-S1616KFR-16-45	16	4	16	16	125	4.00	16	45	0.26	GI336	GL12
L	GL2-S1212HFL-12-40	12	3	12	12	100	2.00	12	40	0.11	GI334	GL13
	GL2-S1616KFL-16-45	16	3	16	16	125	2.00	16	45	0.23	GI334	GL12
	GL3-S1212HFL-12-40	12	3	12	12	100	3.00	12	40	0.11	GI335	GL13
	GL3-S1616KFL-16-45	16	3	16	16	125	3.00	16	45	0.23	GI335	GL12
	GL4-S1616KFL-16-45	16	4	16	16	125	4.00	16	45	0.24	GI336	GL12



GI334
GI335
GI336

GL2..
GL3..
GL4..



GL12
GL13

HS 0516
HS 0412

5.0
5.0

M 5
M 4

16
12

HXK 4
HXK 3

İşlenmiş çap için kesme derinlikleri için sayfa 416.

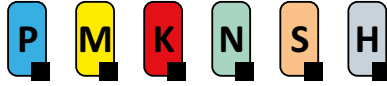
NEW**GLS B**

PRAMET

X**GL Uçlar için Çift Taraflı Kesme Laması**

60mm derinlik ya da Ø120mm çapa kadar kesme işlemleri için lama. Çift taraflı GL uçlar için. 26 ve 32mm yüksekliklerinde. DU Pramet baz tutuculara uygundur. Lama uzun takım ömrü için işlem görmüştür.

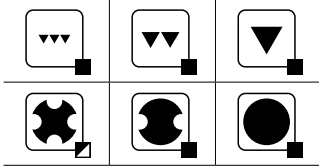
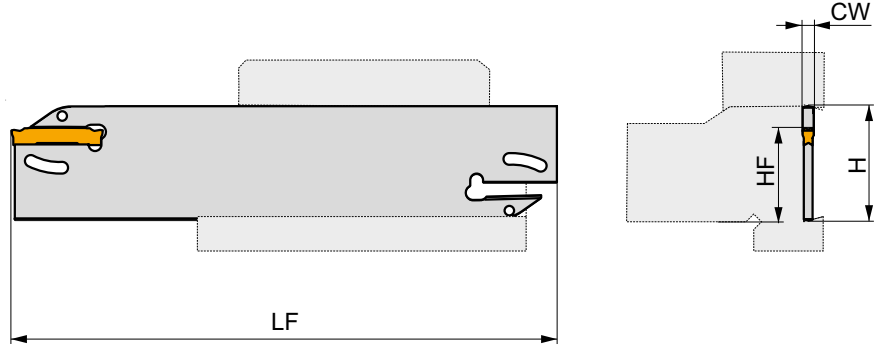
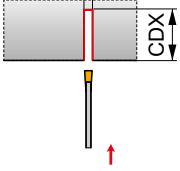

Product	≡ (mm)	H (mm)	LF (mm)	CW (mm)	CDX (mm)	kg	GI334	KV2
GL2-S26KB	21.4	26	125	2.00	35	0.13	GI334	KV2
GL2-S32MB	25	32	150	2.00	50	0.15	GI334	KV2
GL3-S26KB	21.4	26	125	3.00	35	0.15	GI335	KV2
GL3-S32MB	25	32	150	3.00	50	0.16	GI335	KV2
GL4-S32MB	25	32	150	4.00	50	0.16	GI336	KV2
GL5-S32MB	25	32	150	5.00	60	0.16	GI337	KV2
GL6-S32MB	25	32	150	6.00	60	0.16	GI338	KV2

GI334	GI335	GI336	GI337	GI338
GL2..	GL3..	GL4..	GL5..	GL6..

KV2	KV 15x150



DU, D

PRAMET



Kesme Lamaları için Takım Tutucu

GL veya XLC. lamalar için tutucu. 20x20-40x40mm şaft ölçülerinde bulunur. Gövde uzun takım ömrü için işlem görmüştür.

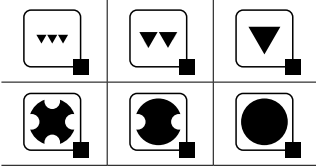
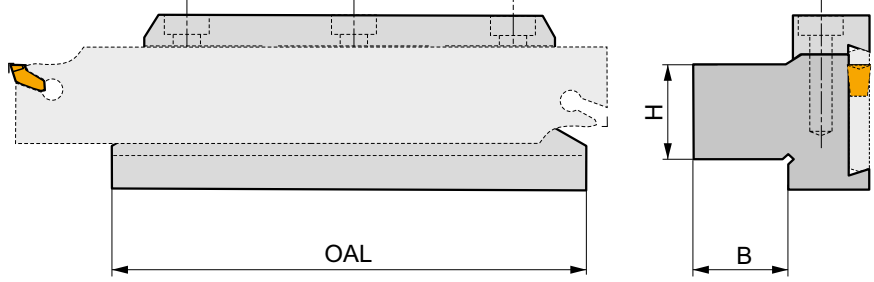
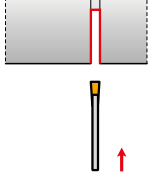

Product	H (mm)	B (mm)	OAL (mm)	kg		
26-DU 2020	20	20	90	0.70	GI007	ND2
26-D 2020	20	20	100	0.82	GI007	ND2
32-DU 2523	25	23	110	1.02	GI008	ND2
32-DU 2532	25	32	110	1.10	GI008	ND2
32-DU 3229	32	29	110	1.25	GI008	ND2
32-D 2530	25	30	115	1.30	GI008	ND2
45-DU 3229	32	29	110	1.50	GI009	ND7
45-DU 4036	40	36	110	2.05	GI009	ND7
47-D 4040	40	40	150	3.88	GI091	ND3

GI007	XLC.N 26..	GL.-S26.B
GI008	XLC.N 32..	GL.-S32.B
GI009	XLC.N 45..	-
GI091	XLC.N 47..	-

ND2	HS 0625	6.0	M 6	25	HXK 5
ND3	HS 1030	8.0	M 10	30	HXK 8
ND7	HS 0630	6.0	M 6	30	HXK 5



İŞLENMİŞ ÇAPA GÖRE KESME DERİNLİKLERİ

GLSF (RL) EXT

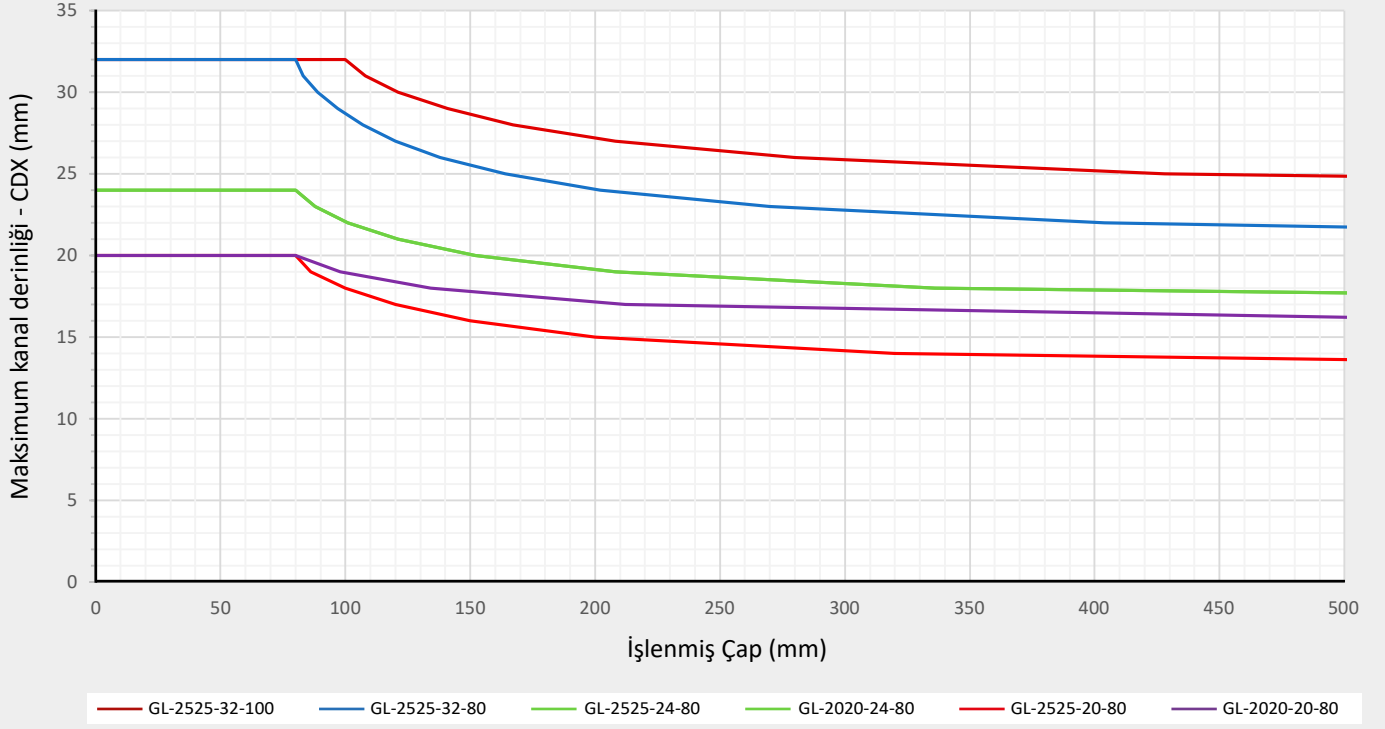

GLSF (RL) EXT-S

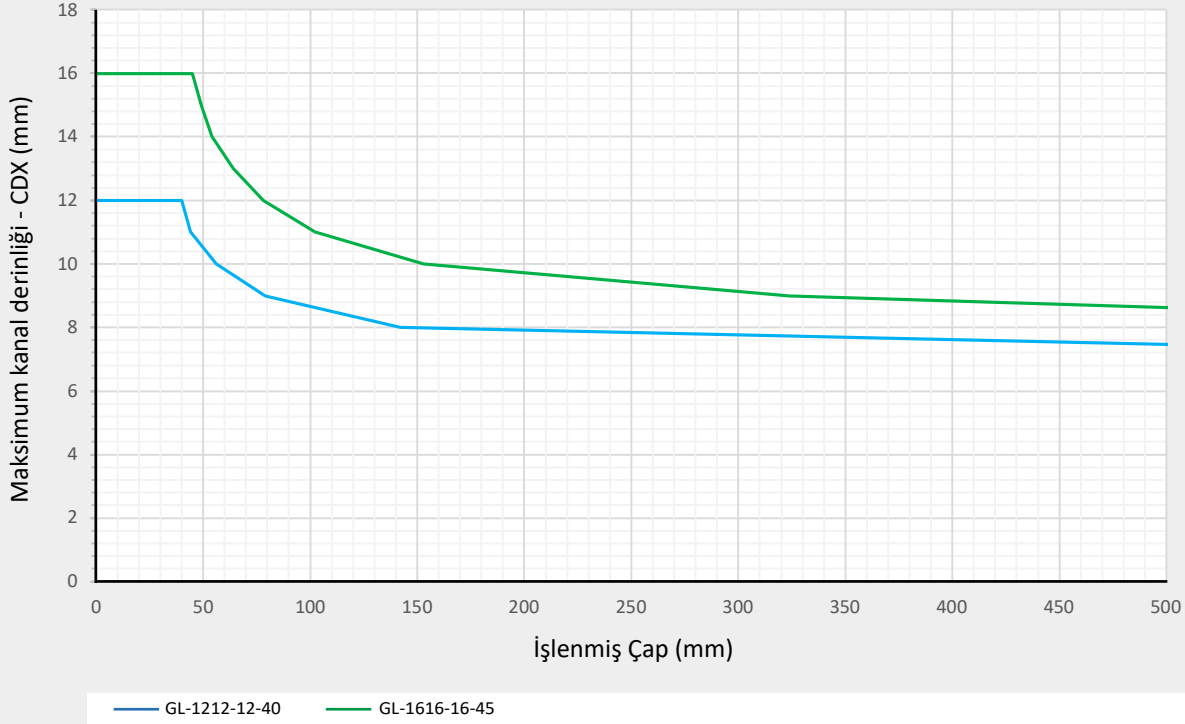



İŞLENMİŞ ÇAPA GÖRE KESME DERİNLİKLERİ

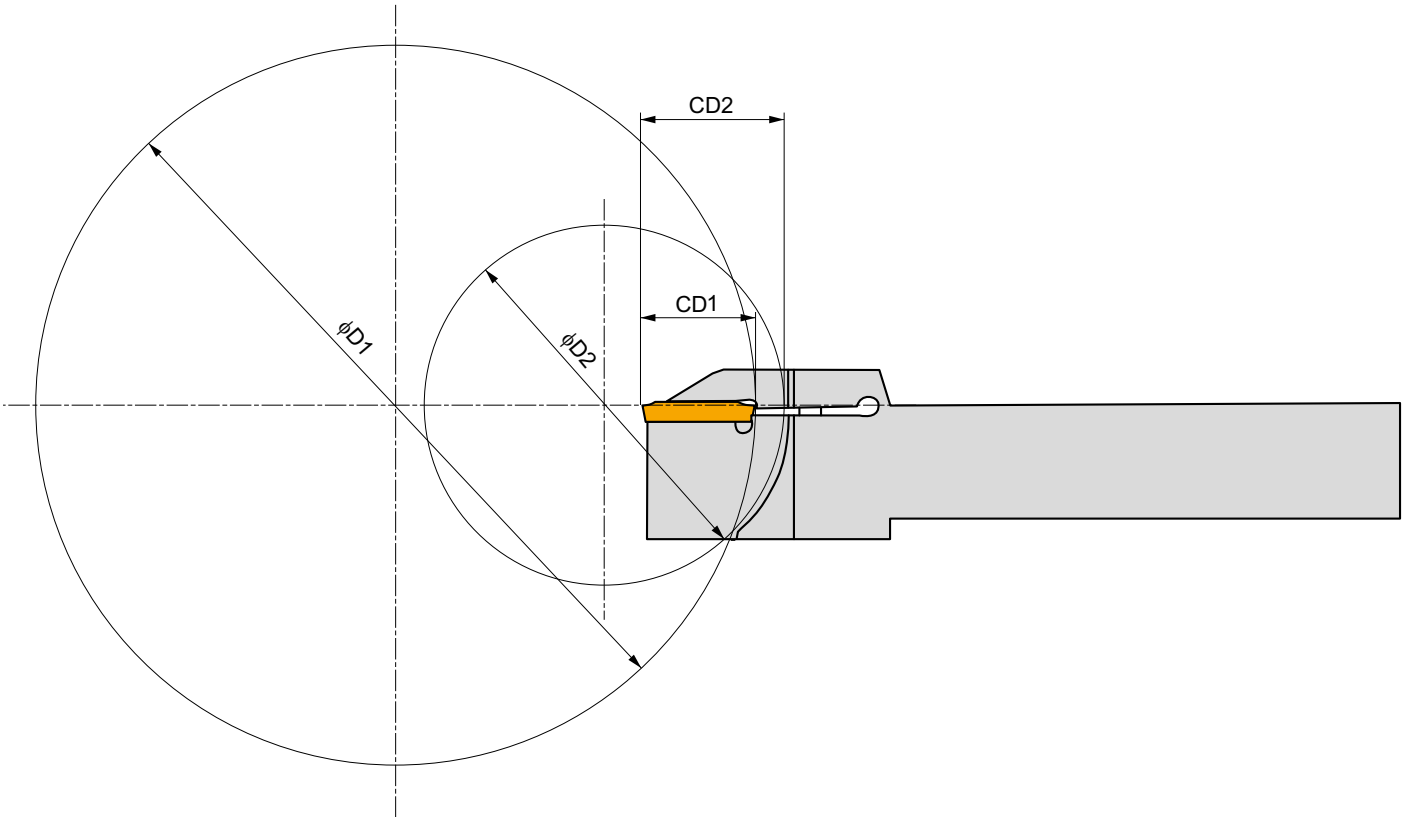



LCMF 13 - CM

PRAMET

	CW	CWTOLL	CWTOLU	INSL
	(mm)	(mm)	(mm)	(mm)
0313	3.00	-0.05	0.05	12.6
0413	4.00	-0.05	0.05	12.6

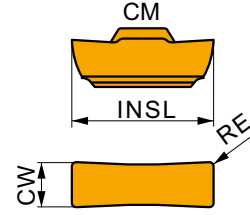

Kesme hızı (vc), ilerleme (f) için uygunluk ve başlangıç değerleri. Daha ileri hesaplamalar için İşleme Hesaplayıcısı uygulamasına başvurun.

Product	RE	P		M		K		N		S		H		PSIRR	PSIRL
		vc	f	vc	f	vc	f	vc	f	vc	f	vc	f		
	(mm)	(m/min)	(mm/rev)	(m/min)	(mm/rev)	(m/min)	(mm/rev)	(m/min)	(mm/rev)	(m/min)	(mm/rev)	(m/min)	(mm/rev)	(°)	(°)

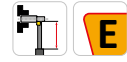
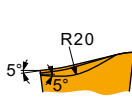

CM geometri ve kanal açma için ilk tercih.

LCMF 031304-CM	T8330	0.4	130	0.11	75	0.10	120	0.11	-	-	-	-	-	-	-
LCMF 031304-CM-04	T8330 ¹⁾	0.4	130	0.11	75	0.10	120	0.11	-	-	-	-	-	-	-
LCMF 041304-CM	T8330	0.4	130	0.11	75	0.10	120	0.11	-	-	-	-	-	-	-

¹⁾ Insert for internal holder A16Q-GGERIL0313-04, A20R-GGFRIL0313-04.

LCMF 13 - F

PRAMET

	CW	CWTOLL	CWTOLU	INSL
	(mm)	(mm)	(mm)	(mm)
0313	3.00	-0.05	0.05	12.6
0413	4.00	-0.05	0.05	12.6

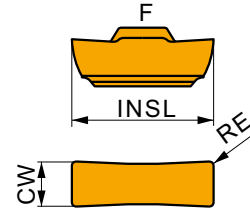

Kesme hızı (vc), ilerleme (f) ve kesme derinliği (ap) için uygunluk ve başlangıç değerleri. Daha ileri hesaplamalar için İşleme Hesaplayıcısı uygulamasına başvurun.

Product	RE	P			M			K			N			S			H		
		vc	f	ap	vc	f	ap	vc	f	ap	vc	f	ap	vc	f	ap	vc	f	ap
	(mm)	(m/min)	(mm/rev)	(mm)	(m/min)	(mm/rev)	(mm)	(m/min)	(mm/rev)	(mm)	(m/min)	(mm/rev)	(mm)	(m/min)	(mm/rev)	(mm)	(m/min)	(mm/rev)	(mm)

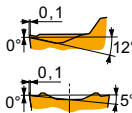

F geometri ve tornalama için ilk tercih.

LCMF 031302-F	T8330	0.2	195	0.10	0.3	115	0.09	0.3	185	0.10	0.3	-	-	-	-	-	-	-	-
LCMF 031302-F-04	T8330 ¹⁾	0.2	195	0.10	0.3	115	0.09	0.3	185	0.10	0.3	-	-	-	-	-	-	-	-
LCMF 031304-F	T8330	0.4	185	0.13	0.5	110	0.12	0.5	175	0.13	0.5	-	-	-	-	-	-	-	-
LCMF 031304-F-04	T8330 ¹⁾	0.4	185	0.13	0.5	110	0.12	0.5	175	0.13	0.5	-	-	-	-	-	-	-	-
LCMF 041304-F	T8330	0.4	185	0.13	0.5	110	0.12	0.5	175	0.13	0.5	-	-	-	-	-	-	-	-
	T9325	0.4	275	0.13	0.5	165	0.12	0.5	260	0.13	0.5	-	-	-	-	-	-	-	-

¹⁾ Insert for internal holder A16Q-GGERIL0313-04, A20R-GGFRIL0313-04.



LCMF 13 - MP

PRAMET

	CW	CWTOLL	CWTOLU	INSL
	(mm)	(mm)	(mm)	(mm)
0313	3.00	-0.05	0.05	12.6
0413	4.00	-0.05	0.05	12.6

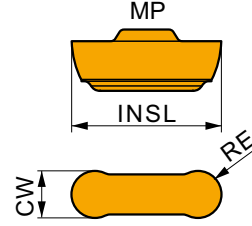

Kesme hızı (vc), ilerleme (f) ve kesme derinliği (ap) için uygunluk ve başlangıç değerleri. Daha ileri hesaplamalar için İşleme Hesaplayıcısı uygulamasına başvurun.

Product	RE	P			M			K			N			S			H		
		vc	f	ap	vc	f	ap	vc	f	ap	vc	f	ap	vc	f	ap			
	(mm)	(m/min)	(mm/rev)	(mm)	(m/min)	(mm/rev)	(mm)	(m/min)	(mm/rev)	(mm)	(m/min)	(mm/rev)	(mm)	(m/min)	(mm/rev)	(mm)	(m/min)	(mm/rev)	(mm)

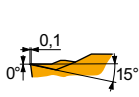

MP geometri, kopya profil ve çap tormalama, ince ve finiş işleme için, ve darbesizden darbeli kesime kadar uygun.

LCMF 0313MO-MP	T8330	1.5	■	190	0.30	0.8	▣	110	0.27	0.8	■	180	0.30	0.8	■	-	-	-	-	-	-
LCMF 0313MO-MP-04	T8330 ¹⁾	1.5	■	190	0.30	0.8	▣	110	0.27	0.8	■	180	0.30	0.8	■	-	-	-	-	-	-
LCMF 0413MO-MP	T8330	2.0	■	175	0.40	1.0	▣	105	0.36	1.0	■	165	0.40	1.0	■	-	-	-	-	-	-

¹⁾ Insert for internal holder A16Q-GGERIL0313-04, A20R-GGFRIL0313-04.

LCMR 13 - F

PRAMET

	CW	CWTOLL	CWTOLU	INSL
	(mm)	(mm)	(mm)	(mm)
0313	3.00	-0.05	0.05	12.6
0413	4.00	-0.05	0.05	12.6

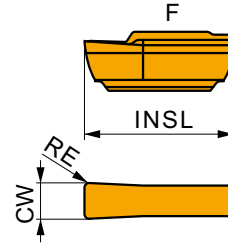

Kesme hızı (vc), ilerleme (f) ve kesme derinliği (ap) için uygunluk ve başlangıç değerleri. Daha ileri hesaplamalar için İşleme Hesaplayıcısı uygulamasına başvurun.

Product	RE	P			M			K			N			S			H		
		vc	f	ap	vc	f	ap	vc	f	ap	vc	f	ap	vc	f	ap			
	(mm)	(m/min)	(mm/rev)	(mm)	(m/min)	(mm/rev)	(mm)	(m/min)	(mm/rev)	(mm)	(m/min)	(mm/rev)	(mm)	(m/min)	(mm/rev)	(mm)	(m/min)	(mm/rev)	(mm)

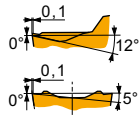

F geometri, kanal açma ve tormalama için, ince ve finiş işleme, ve darbesizden hafif darbeye kadar uygun.

LCMR 031304-F	T8330	0.4	■	185	0.13	0.5	▣	110	0.12	0.5	■	175	0.13	0.5	■	-	-	-	-	-	-
LCMR 041304-F	T8330	0.4	■	185	0.13	0.5	▣	110	0.12	0.5	■	175	0.13	0.5	■	-	-	-	-	-	-



LCMR 13 - MP

PRAMET

	CW	CWTOLL	CWTOLU	INSL
	(mm)	(mm)	(mm)	(mm)
0313	3.00	-0.05	0.05	12.6
0413	4.00	-0.05	0.05	12.6

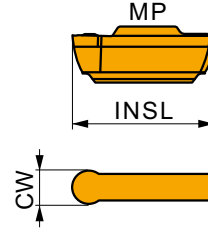

Kesme hızı (vc), ilerleme (f) ve kesme derinliği (ap) için uygunluk ve başlangıç değerleri. Daha ileri hesaplamalar için İşleme Hesaplayıcısı uygulamasına başvurun.

Product	RE (mm)	P			M			K			N			S			H		
		vc (m/min)	f (mm/rev)	ap (mm)	vc (m/min)	f (mm/rev)	ap (mm)	vc (m/min)	f (mm/rev)	ap (mm)	vc (m/min)	f (mm/rev)	ap (mm)	vc (m/min)	f (mm/rev)	ap (mm)			

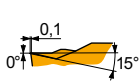

MP geometri, kopya profil ve çap tormalama, ve darbesizden darbeli kesime kadar uygun.

LCMR 0313MO-MP	T8330	1.5	190	0.30	0.8	110	0.27	0.8	180	0.30	0.8	-	-	-	-	-	-	-
LCMR 0413MO-MP	T8330	2.0	175	0.40	1.0	105	0.36	1.0	165	0.40	1.0	-	-	-	-	-	-	-



GG.(RL) INT

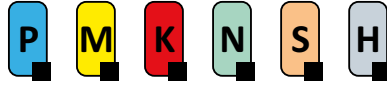

PRAMET

G



LCM. Uç için Delik Kanal Kateri

LCM. 0313 veya 0413 uçlar için Sağ/Sol delik kanal kateri. Minimum kanal açma çapı Ø16mm. Delik içi kanal açma ve çok yönlü tornalama için uygundur. Ø16-32mm shaft ölçülerinde bulunur. Gövde uzun takım ömrü için işlem görmüştür.

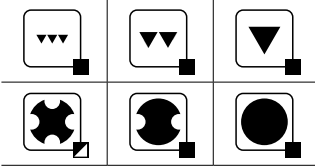
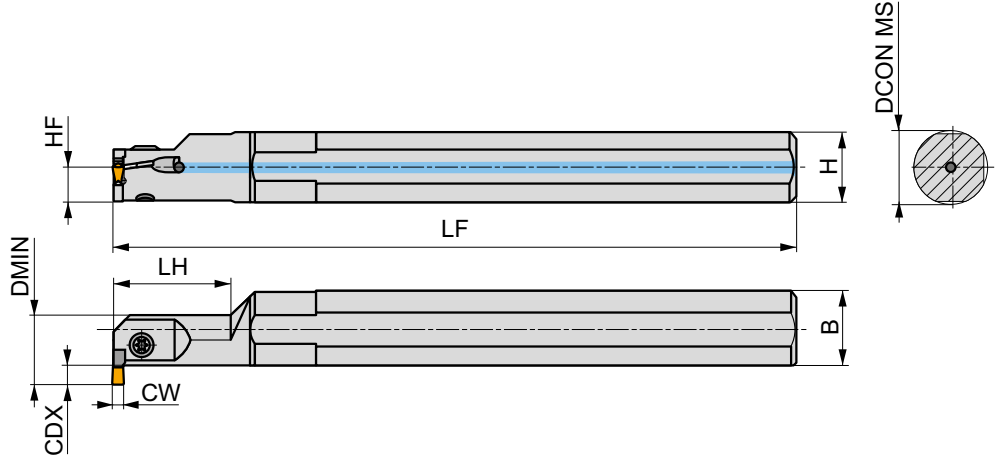
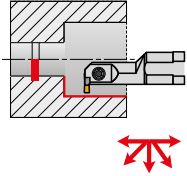

Product	DCON MS (mm)	HF (mm)	H (mm)	B (mm)	LF (mm)	LH (mm)	CW (mm)	CDX (mm)	DMIN (mm)				
R A16Q-GGER 0313	16	7.5	15	15.5	180	25	3.00	3	16	✓	0.26	GI143	GL06
A16Q-GGER 0313-04	16	7.5	15	15.5	180	25	3.00	3	16	✓	0.26	GI190	GL06
A20R-GGFR 0313	20	9	18	19	200	30	3.00	4.5	20	✓	0.36	GI143	GL06
A20R-GGFR 0313-04	20	9	18	19	200	30	3.00	4.5	20	✓	0.39	GI190	GL06
A25S-GGHR 0313	25	11.5	23	24	250	40	3.00	6.5	25	✓	0.78	GI143	GL06
A25S-GGFR 0413	25	11.5	23	24	250	40	4.00	6.5	25	✓	0.73	GI170	GL06
A32T-GGHR 0413	32	15	30	31	300	50	4.00	9.5	32	✓	1.59	GI170	GL06
L A16Q-GGEL 0313	16	7.5	15	15.5	180	25	3.00	3	16	✓	0.29	GI143	GL06
A16Q-GGEL 0313-04	16	7.5	15	15.5	180	25	3.00	3	16	✓	0.28	GI190	GL06
A20R-GGFL 0313	20	9	18	19	200	30	3.00	4.5	20	✓	0.38	GI143	GL06
A20R-GGFL 0313-04	20	9	18	19	200	30	3.00	4.5	20	✓	0.38	GI190	GL06
A25S-GGHL 0313	25	11.5	23	24	250	40	3.00	6.5	25	✓	0.81	GI143	GL06
A25S-GGFL 0413	25	11.5	23	24	250	40	4.00	6.5	25	✓	0.82	GI170	GL06
A32T-GGHL 0413	32	15	30	31	300	50	4.00	9.5	32	✓	1.59	GI170	GL06



GI143

LCM. 0313..

GI170

LCM. 0413..

GI190

LCM. 0313.....-04



GL06

SR 85011-T15P

5.0

M 5

9

FLAGT15P



GFIL-L AXIAL



PRAMET

G



LCM. 03 Uç için V-Kanal Sıkmalı Dış Aksiyel Kanal Açma Diş Kateri

Tek veya çift taraflı LCM. 0313 ya da 0316 uçlar için sol kesme yönlü aksiyel kanal açma diş kateri. Aksiyel kanal açma, aksiyel profil işleme veya kanal genişletme. Ø17-170mm ve 9mm maksimum kesme derinliği. 25x25mm şaft ölçüleri. Gövde uzun takım ömrü için işlem görmüştür.

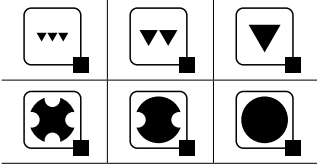
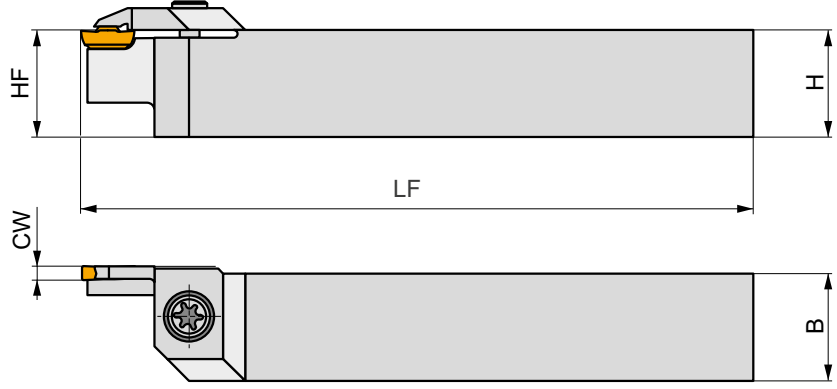
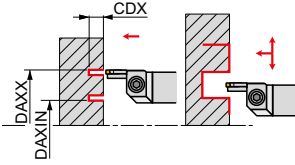

Product	HF	H	B	LF	CW	CDX	DAXIN	DAXX	kg	G1143	G1143
	(mm)	(mm)	(mm)	(mm)	(mm)	(mm)	(mm)	(mm)			
GFIL 2525 M 0313L 030017	25	25	25	150	3.00	9	17	30	0.64	G1143	GL02
GFIL 2525 M 0313L 039024	25	25	25	150	3.00	9	24	39	0.66	G1143	GL07
GFIL 2525 M 0313L 050033	25	25	25	150	3.00	9	33	50	0.67	G1143	GL07
GFIL 2525 M 0313L 060043	25	25	25	150	3.00	9	43	60	0.67	G1143	GL07
GFIL 2525 M 0313L 076053	25	25	25	150	3.00	9	53	76	0.67	G1143	GL07
GFIL 2525 M 0316L 100070	25	25	25	150	3.00	9	70	100	0.69	G1136	GL07
GFIL 2525 M 0316L 130090	25	25	25	150	3.00	9	90	130	0.70	G1136	GL07
GFIL 2525 M 0316L 170110	25	25	25	150	3.00	9	110	170	0.71	G1136	GL07



G1136
G1143



LCM. 0316..
LCM. 0313..



GL02
GL07



US 5015-T20P
US 5018-T20P



5.0
5.0



M 5
M 5



15
18.2



FLAGT20P
FLAGT20P



GFIL-R AXIAL

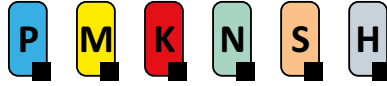

PRAMET

G



LCM. 03 veya 04 Uç için V-Kanal Sıkmalı Dış Aksiyel Kanal Kateri

Tek veya çift taraflı LCM. 0313, 0316, 0413 ya da 0416 uçlar için sol kesme yönlü aksiyel kanal açma dış kateri. Aksiyel kanal açma, aksiyel profil işleme veya kanal genişletme. Ø17-230mm ve 12mm maksimum kesme derinliği. 25x25mm şaft ölçüleri. Gövde uzun takım ömrü için işlem görmüştür.

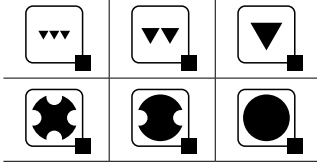
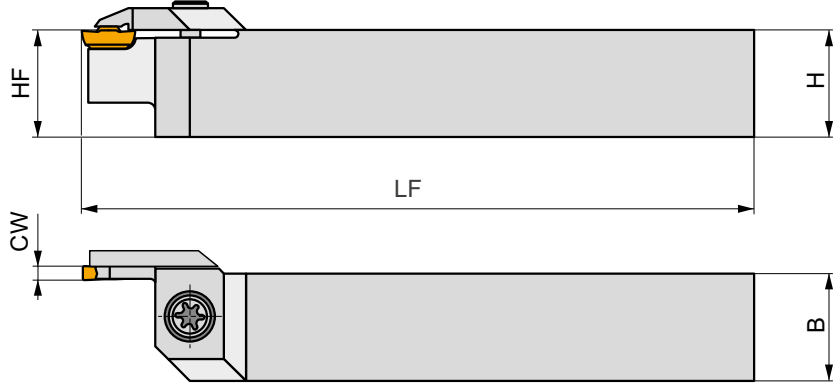
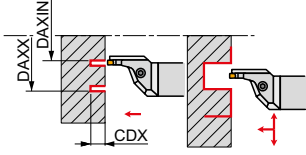

Product	HF	H	B	LF	CW	CDX	DAXIN	DAXX	kg		
	(mm)	(mm)	(mm)	(mm)	(mm)	(mm)	(mm)	(mm)			
L GFIL 2525 M 03R 030017-A	25	25	25	150	3.00	9	17	30	0.69	G1143	GL07
GFIL 2525 M 03R 039024-A	25	25	25	150	3.00	9	24	39	0.69	G1143	GL07
GFIL 2525 M 03R 050033-A	25	25	25	150	3.00	9	33	50	0.72	G1143	GL07
GFIL 2525 M 03R 060043-A	25	25	25	150	3.00	9	43	60	0.69	G1143	GL07
GFIL 2525 M 03R 076053-A	25	25	25	150	3.00	9	53	76	0.68	G1143	GL07
GFIL 2525 M 03R 100070-A	25	25	25	150	3.00	9	70	100	0.79	G1136	GL08
GFIL 2525 M 03R 130090-A	25	25	25	150	3.00	9	90	130	0.73	G1136	GL08
GFIL 2525 M 03R 170110-A	25	25	25	150	3.00	9	110	170	0.76	G1136	GL08
GFIL 2525 M 04R 030017-A	25	25	25	150	3.00	9	17	30	0.71	G1170	GL07
GFIL 2525 M 04R 034021-A	25	25	25	150	4.00	9	21	34	0.69	G1170	GL07
GFIL 2525 M 04R 040026-A	25	25	25	150	4.00	11	26	40	0.00	G1170	GL07
GFIL 2525 M 04R 050032-A	25	25	25	150	4.00	11	32	50	0.68	G1170	GL07
GFIL 2525 M 04R 060042-A	25	25	25	150	4.00	11	42	60	0.66	G1170	GL07
GFIL 2525 M 04R 075052-A	25	25	25	150	4.00	11	52	75	0.67	G1170	GL07
GFIL 2525 M 04R 100070-A	25	25	25	150	4.00	12	70	100	0.75	G1137	GL08
GFIL 2525 M 04R 130090-A	25	25	25	150	4.00	12	90	130	0.75	G1137	GL08
GFIL 2525 M 04R 170110-A	25	25	25	150	4.00	12	110	170	0.75	G1137	GL08
GFIL 2525 M 04R 230140-A	25	25	25	150	4.00	12	140	230	0.78	G1137	GL08



G1136	LCM. 0316..
G1137	LCM. 0416..
G1143	LCM. 0313..
G1170	LCM. 0413..



GL07	US 5018-T20P	5.0	M 5	18.2	FLAG T20P	-
GL08	US 6020-T25P	6.0	M 6	20.2	-	SDRT25P



GFIR-L AXIAL



PRAMET

G



LCM. 03/04 Uç için V-Kanal Sıkmalı Dış Kanal Kateri

LCM. 0313, 0316, 0413 veya 0416 uçlar için sağ aksiyel dış kanal kateri. Ø17-230mm çap aralığında 12mm aralığında aksiyel kanal açma, aksiyel profil işleme ve kanal genişletme için uygundur. 25x25 şaft ölçülerinde bulunur. Uzun takım ömrü ve düşük titreşim için güçlendirilmiş gövde. Gövde uzun takım ömrü için işlem görmüştür.

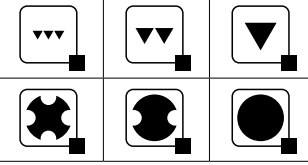
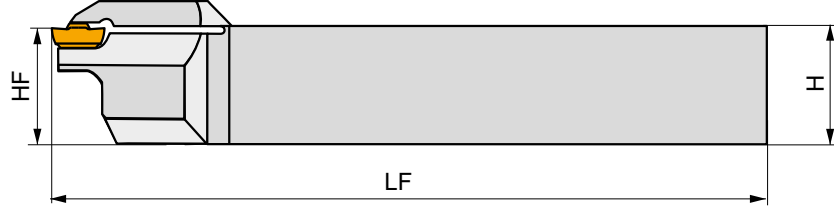
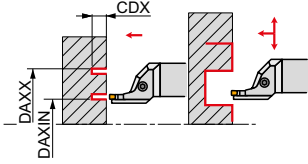

Product	HF	H	B	LF	CW	CDX	DAXIN	DAXX	kg		
	(mm)	(mm)	(mm)	(mm)	(mm)	(mm)	(mm)	(mm)			
GFIR 2525 M 03L 030017-A	25	25	25	150	3.00	9	17	30	0.65	G1143	GL07
GFIR 2525 M 03L 039024-A	25	25	25	150	3.00	9	24	39	0.68	G1143	GL07
GFIR 2525 M 03L 050033-A	25	25	25	150	3.00	9	33	50	0.65	G1143	GL07
GFIR 2525 M 03L 060043-A	25	25	25	150	3.00	9	43	60	0.68	G1143	GL07
GFIR 2525 M 03L 076053-A	25	25	25	150	3.00	9	53	76	0.69	G1143	GL07
GFIR 2525 M 03L 100070-A	25	25	25	150	3.00	9	70	100	0.75	G1136	GL08
GFIR 2525 M 03L 130090-A	25	25	25	150	3.00	9	90	130	0.76	G1136	GL08
GFIR 2525 M 03L 170110-A	25	25	25	150	3.00	9	110	170	0.68	G1136	GL08
GFIR 2525 M 04L 030017-A	25	25	25	150	3.00	9	17	30	0.68	G1170	GL07
GFIR 2525 M 04L 034021-A	25	25	25	150	4.00	9	21	34	0.68	G1170	GL07
GFIR 2525 M 04L 040026-A	25	25	25	150	4.00	11	26	40	0.68	G1170	GL07
GFIR 2525 M 04L 050032-A	25	25	25	150	4.00	11	32	50	0.66	G1170	GL07
GFIR 2525 M 04L 060042-A	25	25	25	150	4.00	11	42	60	0.69	G1170	GL07
GFIR 2525 M 04L 075052-A	25	25	25	150	4.00	11	52	75	0.67	G1170	GL07
GFIR 2525 M 04L 100070-A	25	25	25	150	4.00	12	70	100	0.72	G1137	GL08
GFIR 2525 M 04L 130090-A	25	25	25	150	4.00	12	90	130	0.75	G1137	GL08
GFIR 2525 M 04L 170110-A	25	25	25	150	4.00	12	110	170	0.72	G1137	GL08
GFIR 2525 M 04L 230140-A	25	25	25	150	4.00	12	140	230	0.79	G1137	GL08



G1136
G1137
G1143
G1170

LCM. 0316..
LCM. 0416..
LCM. 0313..
LCM. 0413..



GL07
GL08

US 5018-T20P
US 6020-T25P

5.0
6.0

M 5
M 6

18.2
20.2

FLAG T20P
-

-
SDRT25P



GFIR-R AXIAL

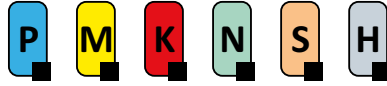

PRAMET

G



LCM. 03 Uç için V-Kanal Sıkmalı Dış Kanal Kateri

LCM. 0313 veya 0316 uçlar için sağ aksiyel dış kanal kateri. Ø17-70mm çap aralığında, 9mm derinliğinde aksiyel kanal açma, aksiyel profil işleme ve kanal genişletme için uygundur. 20x20-32x25 şaft ölçülerinde bulunur. Uzun takım ömrü ve düşük titreşim için güçlendirilmiş gövde. Gövde uzun takım ömrü için işlem görmüştür.

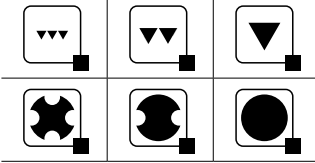
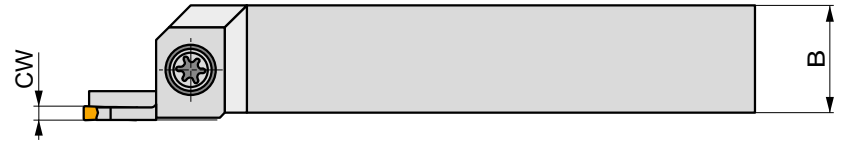
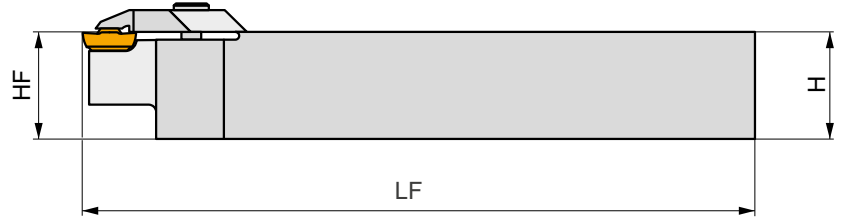
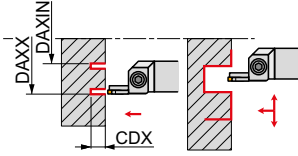

Product	HF	H	B	LF	CW	CDX	DAXIN	DAXX	kg	GL	GL
	(mm)	(mm)	(mm)	(mm)	(mm)	(mm)	(mm)	(mm)			
GFIR 2525 M 0313R 030017	25	25	25	150	3.00	9	17	30	0.65	GI143	GL02
GFIR 2525 M 0313R 039024	25	25	25	150	3.00	9	24	39	0.66	GI143	GL07
GFIR 2525 M 0313R 050033	25	25	25	150	3.00	9	33	50	0.68	GI143	GL07
GFIR 2525 M 0313R 060043	25	25	25	150	3.00	9	43	60	0.68	GI143	GL07
GFIR 2525 M 0313R 076053	25	25	25	150	3.00	9	53	76	0.68	GI143	GL07
GFIR 2525 M 0316R 100070	25	25	25	150	3.00	9	70	100	0.69	GI136	GL07
GFIR 2525 M 0316R 130090	25	25	25	150	3.00	9	90	130	0.70	GI136	GL07
GFIR 2525 M 0316R 170110	25	25	25	150	3.00	9	110	170	0.70	GI136	GL07



GI136
GI143

LCM. 0316..
LCM. 0313..



GL02
GL07

US 5015-T20P
US 5018-T20P

5.0
5.0

M 5
M 5

15
18.2

FLAG T20P
FLAG T20P



GFML-L AXIAL



PRAMET

G



LCM. 04 Uç için V-Kanal Sıkmalı Dış Aksiyel Kanal Açma Dış Kateri

Tek veya çift taraflı LCM. 0413 ya da 0416 uçlar için sol kesme yönlü aksiyel kanal açma dış kateri. Derin aksiyel kanal açma, aksiyel profil işleme veya kanal genişletme. Ø17-230mm ve 20mm maksimum kesme derinliği. 25x25mm şaft ölçüleri. Gövde uzun takım ömrü için işlem görmüştür.

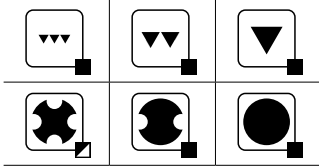
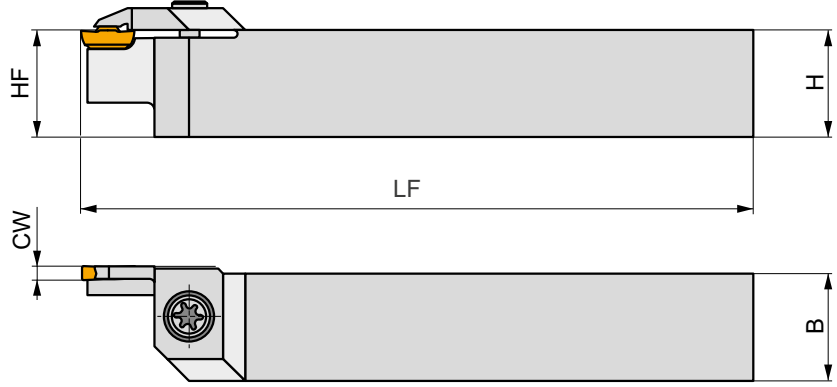
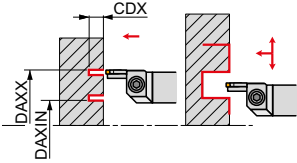

Product	HF	H	B	LF	CW	CDX	DAXIN	DAXX	kg	G1170	GL02
	(mm)	(mm)	(mm)	(mm)	(mm)	(mm)	(mm)	(mm)			
GFML 2525 M 0413L 030017	25	25	25	150	4.00	20	17	30	0.62	G1170	GL02
GFML 2525 M 0413L 034021	25	25	25	150	4.00	20	21	34	0.63	G1170	GL07
GFML 2525 M 0413L 040026	25	25	25	150	4.00	20	26	40	0.65	G1170	GL07
GFML 2525 M 0413L 050032	25	25	25	150	4.00	20	32	50	0.64	G1170	GL07
GFML 2525 M 0413L 060042	25	25	25	150	4.00	20	42	60	0.65	G1170	GL07
GFML 2525 M 0413L 075052	25	25	25	150	4.00	20	52	75	0.66	G1170	GL07
GFML 2525 M 0416L 100070	25	25	25	150	4.00	20	70	100	0.66	G1137	GL07
GFML 2525 M 0416L 130090	25	25	25	150	4.00	20	90	130	0.67	G1137	GL07
GFML 2525 M 0416L 170110	25	25	25	150	4.00	20	110	170	0.67	G1137	GL07
GFML 2525 M 0416L 230140	25	25	25	150	4.00	20	140	230	0.67	G1137	GL07



G1137
G1170

LCM. 0416..
LCM. 0413..



GL02
GL07

US 5015-T20P
US 5018-T20P

5.0
5.0

M 5
M 5

15
18.2

FLAG T20P
FLAG T20P



GFML-R AXIAL



PRAMET

G



LCM. 04 Uç için V-Kanal Sıkmalı Dış Aksiyel Kanal Kateri

Tek veya çift taraflı LCM. 0413 ya da 0416 uçlar için sol kesme yönlü aksiyel kanal açma dış kateri. Derin aksiyel kanal açma, aksiyel profil işleme veya kanal genişletme. Ø17-230mm ve 20mm maksimum kesme derinliği. 25x25mm şaft ölçüleri. Gövde uzun takım ömrü için işlem görmüştür.

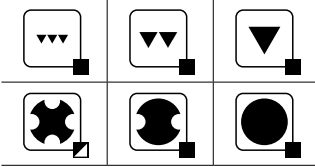
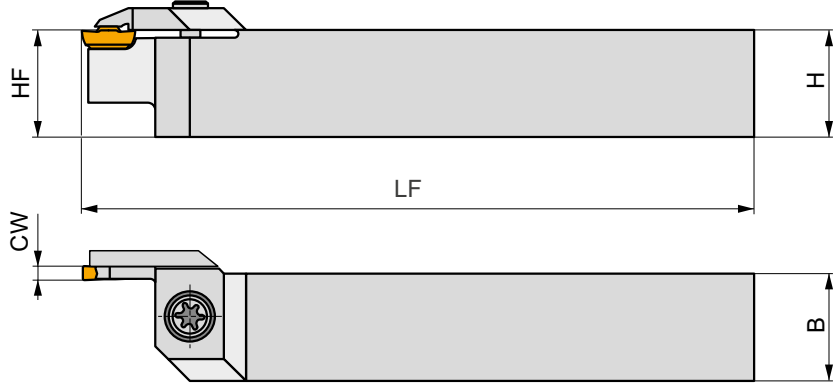
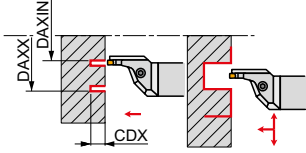

Product	HF	H	B	LF	CW	CDX	DAXIN	DAXX	kg	G170	G1170
	(mm)	(mm)	(mm)	(mm)	(mm)	(mm)	(mm)	(mm)			
GFML 2525 M 0413R 030017	25	25	25	150	4.00	20	17	30	0.68	G1170	GL07
GFML 2525 M 0413R 034021	25	25	25	150	4.00	20	21	34	0.69	G1170	GL07
GFML 2525 M 0413R 040026	25	25	25	150	4.00	20	26	40	0.69	G1170	GL07
GFML 2525 M 0413R 050032	25	25	25	150	4.00	20	32	50	0.68	G1170	GL07
GFML 2525 M 0413R 060042	25	25	25	150	4.00	20	42	60	0.69	G1170	GL07
GFML 2525 M 0413R 075052	25	25	25	150	4.00	20	52	75	0.69	G1170	GL07
GFML 2525 M 0416R 100070	25	25	25	150	4.00	20	70	100	0.80	G1137	GL08
GFML 2525 M 0416R 130090	25	25	25	150	4.00	20	90	130	0.78	G1137	GL08
GFML 2525 M 0416R 170110	25	25	25	150	4.00	20	110	170	0.78	G1137	GL08
GFML 2525 M 0416R 230140	25	25	25	150	4.00	20	140	230	0.78	G1137	GL08



G1137
G1170



LCM. 0416..

LCM. 0413..



GL07

US 5018-T20P

5.0

M 5

18.2

FLAGT20P

-

GL08

US 6020-T25P

6.0

M 6

20.2

-

SDRT25P



GFMR-L AXIAL



PRAMET

G



LCM. 04 Uç için V-Kanal Sıkmalı Dış Kanal Kateri

LCM. 0413 ve 0416 uçlar için sağ aksiyel dış kanal kateri. Ø17-230mm çap aralığında 20mm aralığında aksiyel kanal açma, aksiyel profil işleme ve kanal genişletme için uygundur. 25x25 şaft ölçülerinde bulunur. Gövde uzun takım ömrü için işlem görmüştür.

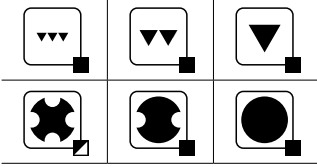
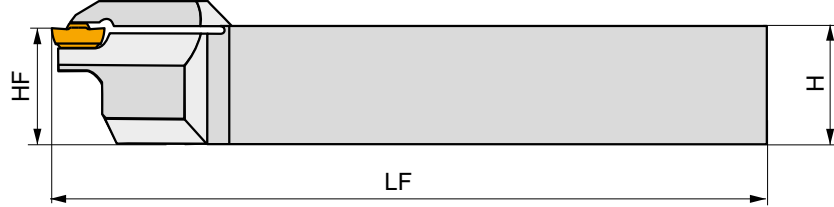
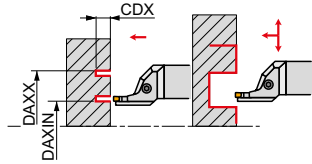

Product	HF	H	B	LF	CW	CDX	DAXIN	DAXX	kg	G1170	GL07
	(mm)	(mm)	(mm)	(mm)	(mm)	(mm)	(mm)	(mm)			
GFMR 2525 M 0413L 030017	25	25	25	150	4.00	20	17	30	0.70	G1170	GL07
GFMR 2525 M 0413L 034021	25	25	25	150	4.00	20	21	34	0.66	G1170	GL07
GFMR 2525 M 0413L 040026	25	25	25	150	4.00	20	26	40	0.66	G1170	GL07
GFMR 2525 M 0413L 050032	25	25	25	150	4.00	20	32	50	0.68	G1170	GL07
GFMR 2525 M 0413L 060042	25	25	25	150	4.00	20	42	60	0.66	G1170	GL07
GFMR 2525 M 0413L 075052	25	25	25	150	4.00	20	52	75	0.69	G1170	GL07
GFMR 2525 M 0416L 100070	25	25	25	150	4.00	20	70	100	0.88	G1137	GL08
GFMR 2525 M 0416L 130090	25	25	25	150	4.00	20	90	130	0.78	G1137	GL08
GFMR 2525 M 0416L 170110	25	25	25	150	4.00	20	110	170	0.81	G1137	GL08
GFMR 2525 M 0416L 230140	25	25	25	150	4.00	20	140	230	0.78	G1137	GL08

Product	LCM. 0416..	LCM. 0413..
G1137	LCM. 0416..	LCM. 0413..
G1170	LCM. 0416..	LCM. 0413..

Product	US 5018-T20P	Nm	M 5	18.2	FLAG T20P	-
GL07	US 5018-T20P	5.0	M 5	18.2	FLAG T20P	-
GL08	US 6020-T25P	6.0	M 6	20.2	-	SDRT25P



GFMR-R AXIAL

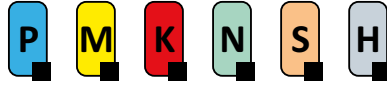

PRAMET

G



LCM. 04 Uç için V-Kanal Sıkmalı Dış Kanal Kateri

LCM. 0413 ve 0416 uçlar için sağ aksiyel dış kanal kateri. Ø17-230mm çap aralığında 20mm aralığında aksiyel kanal açma, aksiyel profil işleme ve kanal genişletme için uygundur. 25x25 şaft ölçülerinde bulunur. Gövde uzun takım ömrü için işlem görmüştür.

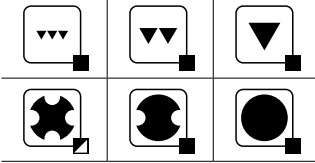
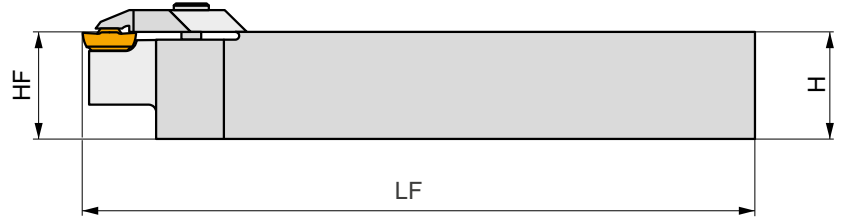
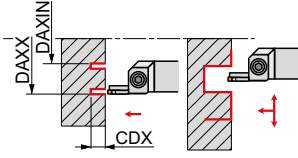

Product	∅	H	B	LF	CW	CDX	DAXIN	DAXX	kg		
	(mm)	(mm)	(mm)	(mm)	(mm)	(mm)	(mm)	(mm)			
GFMR 2525 M 0413R 030017	25	25	25	150	4.00	20	17	30	0.62	G1170	GL02
GFMR 2525 M 0413R 034021	25	25	25	150	4.00	20	21	34	0.63	G1170	GL07
GFMR 2525 M 0413R 040026	25	25	25	150	4.00	20	26	40	0.64	G1170	GL07
GFMR 2525 M 0413R 050032	25	25	25	150	4.00	20	32	50	0.63	G1170	GL07
GFMR 2525 M 0413R 060042	25	25	25	150	4.00	20	42	60	0.64	G1170	GL07
GFMR 2525 M 0413R 075052	25	25	25	150	4.00	20	52	75	0.67	G1170	GL07
GFMR 2525 M 0416R 100070	25	25	25	150	4.00	20	70	100	0.67	G1137	GL07
GFMR 2525 M 0416R 130090	25	25	25	150	4.00	20	90	130	0.66	G1137	GL07
GFMR 2525 M 0416R 170110	25	25	25	150	4.00	20	110	170	0.67	G1137	GL07
GFMR 2525 M 0416R 230140	25	25	25	150	4.00	20	140	230	0.68	G1137	GL07



G1137
G1170

LCM. 0416..
LCM. 0413..



GL02
GL07

US 5015-T20P
US 5018-T20P

5.0
5.0

M 5
M 5

15
18.2

FLAG T20P
FLAG T20P



GGI(RL)-90 AXIAL



PRAMET

G



LCM. 03 Uç için V-Kanal Sıkmalı Dış Aksiyel 90° Kanal Kateri

Tek veya çift taraflı LCM. 0313 ya da 0316 uçlar için Sağ/Sol kesme yönlü aksiyel 90° kanal açma dış kateri. Derin aksiyel kanal açma, aksiyel profil işleme veya kanal genişletme. Ø17-170mm ve 11mm maksimum kesme derinliği. 25x25mm şaft ölçüleri. Gövde uzun takım ömrü için işlem görmüştür.

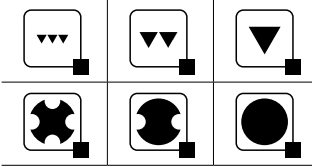
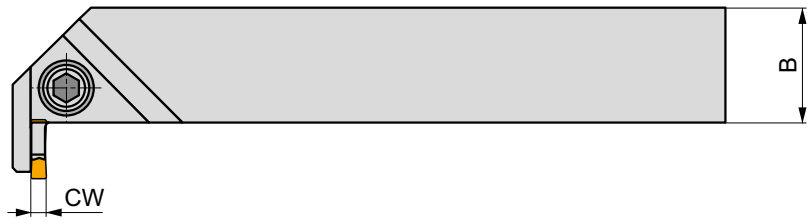
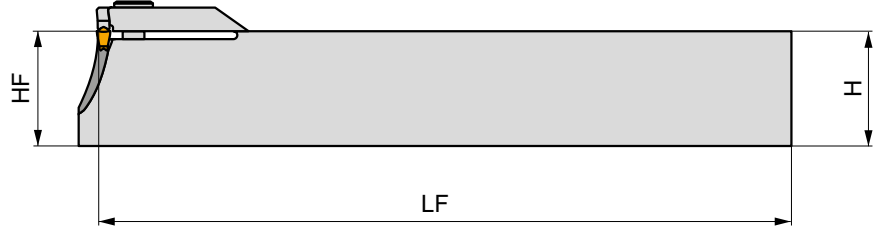
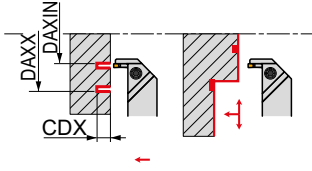

Product	HF	H	B	LF	CW	CDX	DAXIN	DAXX	kg	GI136	GI143
	(mm)	(mm)	(mm)	(mm)	(mm)	(mm)	(mm)	(mm)			
R GGIR 2525 M 03R 030017	25	25	25	150	3.00	9.5	17	30	0.75	GI143	GL01
GGIR 2525 M 03R 039024	25	25	25	150	3.00	9.5	24	39	0.78	GI143	GL01
GGIR 2525 M 03R 050033	25	25	25	150	3.00	11	33	50	0.75	GI143	GL01
GGIR 2525 M 03R 060043	25	25	25	150	3.00	11	43	60	0.78	GI143	GL01
GGIR 2525 M 03R 076053	25	25	25	150	3.00	11	53	76	0.75	GI143	GL01
GGIR 2525 M 03R 100070	25	25	25	150	3.00	9	70	100	0.78	GI136	GL04
GGIR 2525 M 03R 130090	25	25	25	150	3.00	9	90	130	0.73	GI136	GL04
GGIR 2525 M 03R 170110	25	25	25	150	3.00	9	110	170	0.76	GI136	GL04
L GGIL 2525 M 03L 030017	25	25	25	150	3.00	9.5	17	30	0.75	GI143	GL01
GGIL 2525 M 03L 039024	25	25	25	150	3.00	9.5	24	39	0.25	GI143	GL01
GGIL 2525 M 03L 050033	25	25	25	150	3.00	11	33	50	0.75	GI143	GL01
GGIL 2525 M 03L 060043	25	25	25	150	3.00	11	43	60	0.75	GI143	GL01
GGIL 2525 M 03L 076053	25	25	25	150	3.00	11	53	76	0.75	GI143	GL01
GGIL 2525 M 03L 100070	25	25	25	150	3.00	9	70	100	0.77	GI136	GL04
GGIL 2525 M 03L 130090	25	25	25	150	3.00	9	90	130	0.77	GI136	GL04
GGIL 2525 M 03L 170110	25	25	25	150	3.00	9	110	170	0.76	GI136	GL04



GI136

LCM. 0316..

GI143

LCM. 0313..



GL01

HS 0520C

5.0

M 5

20

HXK 4

GL04

HS 0620C

6.0

M 6

20

HXK 5



LCMF 16 - CM

	CW	CWTOLL	CWTOLU	INSL
	(mm)	(mm)	(mm)	(mm)
0316	3.00	-0.05	0.05	16.4
0416	4.00	-0.05	0.05	16.4
0516	5.00	-0.05	0.05	16.4
0616	6.00	-0.05	0.05	16.4

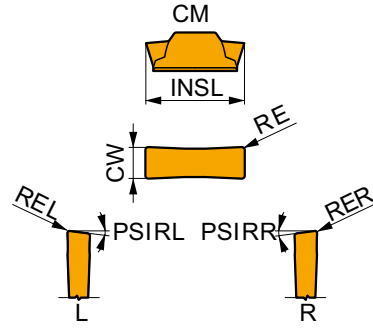

Kesme hızı (vc), ilerleme (f) için uygunluk ve başlangıç değerleri. Daha ileri hesaplamalar için İşleme Hesaplayıcısı uygulamasına başvurun.

Product	RE (mm)	P		M		K		N		S		H		PSIRR (°)	PSIRL (°)
		vc (m/min)	f (mm/rev)	vc (m/min)	f (mm/rev)	vc (m/min)	f (mm/rev)	vc (m/min)	f (mm/rev)	vc (m/min)	f (mm/rev)	vc (m/min)	f (mm/rev)		

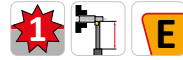
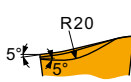

CM geometri, kesme ve kanal açma için ilk tercih, darbesizden hafif darbeleri kesmeye kadar uygun.

LCMF 031602-CM	T8330	0.2	130	0.11	75	0.10	120	0.11	-	-	-	-	-	-	-
LCMF 031604-CM	T8330	0.4	130	0.11	75	0.10	120	0.11	-	-	-	-	-	-	-
LCMF 041602-CM	T8330	0.2	130	0.11	75	0.10	120	0.11	-	-	-	-	-	-	-
LCMF 041604-CM	T8330	0.4	130	0.11	75	0.10	120	0.11	-	-	-	-	-	-	-
LCMF 051604-CM	T8330	0.4	130	0.11	75	0.11	120	0.11	-	-	-	-	-	-	-
LCMF 061604-CM	T8330	0.4	130	0.11	75	0.11	120	0.11	-	-	-	-	-	-	-

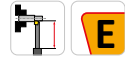
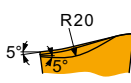

R-CM sol kesme yönlü geometri, kesme için ilk tercih, darbesizden hafif darbeleri kesmeye kadar uygun.

LCMF 031602R15-CM	T8330 ¹⁾	0.2	130	0.11	75	0.10	120	0.11	-	-	-	-	15	-
LCMF 031602R6-CM	T8330	0.2	130	0.11	75	0.10	120	0.11	-	-	-	-	6	-
LCMF 041602R15-CM	T8330 ¹⁾	0.2	130	0.11	75	0.10	120	0.11	-	-	-	-	15	-
LCMF 041602R6-CM	T8330	0.2	130	0.11	75	0.10	120	0.11	-	-	-	-	6	-

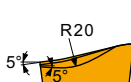

L-CM sol kesme yönlü geometri, kesme için ilk tercih, darbesizden hafif darbeleri kesmeye kadar uygun.

LCMF 031602L15-CM	T8330 ¹⁾	0.2	130	0.11	75	0.10	120	0.11	-	-	-	-	-	15
LCMF 031602L6-CM	T8330	0.2	130	0.11	75	0.10	120	0.11	-	-	-	-	-	6
LCMF 041602L15-CM	T8330 ¹⁾	0.2	130	0.11	75	0.10	120	0.11	-	-	-	-	-	15
LCMF 041602L6-CM	T8330	0.2	130	0.11	75	0.10	120	0.11	-	-	-	-	-	6

¹⁾ Toolholders have to be modified.



LCMF 16, LCMF 30 - F

PRAMET

	CW	CWTOLL	CWTOLU	INSL
	(mm)	(mm)	(mm)	(mm)
0316	3.00	-0.05	0.05	16.4
0416	4.00	-0.05	0.05	16.4
0516	5.00	-0.05	0.05	16.4
0616	6.00	-0.05	0.05	16.4
0830	8.00	-0.05	0.05	30.0

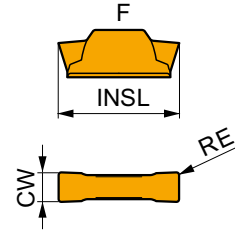

Kesme hızı (vc), ilerleme (f) ve kesme derinliği (ap) için uygunluk ve başlangıç değerleri. Daha ileri hesaplamalar için İşleme Hesaplayıcısı uygulamasına başvurun.

Product	RE	P			M			K			N			S			H		
		vc	f	ap	vc	f	ap	vc	f	ap	vc	f	ap	vc	f	ap	vc	f	ap
	(mm)	(m/min)	(mm/rev)	(mm)	(m/min)	(mm/rev)	(mm)	(m/min)	(mm/rev)	(mm)	(m/min)	(mm/rev)	(mm)	(m/min)	(mm/rev)	(mm)	(m/min)	(mm/rev)	(mm)

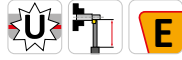
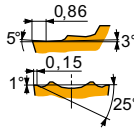

F geometri, kesme, kanal açma ve çap tornalama için, ince ve finiş işleme, ve darbesizden hafif darbeli işlemeye kadar uygun.

LCMF 031602-F	T8330	0.2	■ 195	0.10	0.3	■ 115	0.09	0.3	■ 185	0.10	0.3	-	-	-	-	-	-	-	-
LCMF 031604-F	T8330	0.4	■ 200	0.10	0.5	■ 120	0.09	0.5	■ 190	0.10	0.5	-	-	-	-	-	-	-	-
LCMF 041604-F	T8330	0.4	■ 185	0.13	0.5	■ 110	0.12	0.5	■ 175	0.13	0.5	-	-	-	-	-	-	-	-
	T9325	0.4	■ 275	0.13	0.5	■ 165	0.12	0.5	■ 260	0.13	0.5	-	-	-	-	-	-	-	-
LCMF 041608-F	T8330	0.8	■ 205	0.13	1.0	■ 120	0.12	1.0	■ 190	0.13	1.0	-	-	-	-	-	-	-	-
	T9325	0.8	■ 305	0.13	1.0	■ 180	0.12	1.0	■ 285	0.13	1.0	-	-	-	-	-	-	-	-
LCMF 051608-F	T8330	0.8	■ 195	0.15	1.0	■ 115	0.14	1.0	■ 185	0.15	1.0	-	-	-	-	-	-	-	-
	T9325	0.8	■ 285	0.15	1.0	■ 170	0.14	1.0	■ 270	0.15	1.0	-	-	-	-	-	-	-	-
LCMF 061608-F	T8330	0.8	■ 190	0.17	1.0	■ 110	0.15	1.0	■ 180	0.17	1.0	-	-	-	-	-	-	-	-
	T9325	0.8	■ 270	0.17	1.0	■ 160	0.15	1.0	■ 255	0.17	1.0	-	-	-	-	-	-	-	-

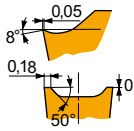

F geometri, kesme, kanal açma ve çap tornalama için, ince ve finiş işleme, ve darbesizden hafif darbeli işlemeye kadar uygun.

LCMF 083008-F	T8330	0.8	■ 175	0.25	1.0	■ 105	0.23	1.0	■ 165	0.25	1.0	-	-	-	-	-	-	-	-
LCMF 083012-F	T8330	1.2	■ 170	0.25	1.5	■ 100	0.23	1.5	■ 160	0.25	1.5	-	-	-	-	-	-	-	-



LCMF 16 - M

PRAMET

	CW	CWTOLL	CWTOLU	INSL
	(mm)	(mm)	(mm)	(mm)
0316	3.00	-0.05	0.05	16.4
0416	4.00	-0.05	0.05	16.4
0516	5.00	-0.05	0.05	16.4
0616	6.00	-0.05	0.05	16.4

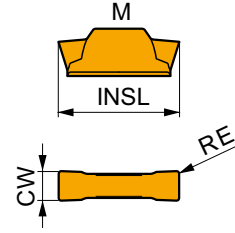

Kesme hızı (vc), ilerleme (f) ve kesme derinliği (ap) için uygunluk ve başlangıç değerleri. Daha ileri hesaplamalar için İşleme Hesaplayıcısı uygulamasına başvurun.

Product	RE	P			M			K			N			S			H		
		vc	f	ap	vc	f	ap	vc	f	ap	vc	f	ap	vc	f	ap			
	(mm)	(m/min)	(mm/rev)	(mm)	(m/min)	(mm/rev)	(mm)	(m/min)	(mm/rev)	(mm)	(m/min)	(mm/rev)	(mm)	(m/min)	(mm/rev)	(mm)	(m/min)	(mm/rev)	(mm)

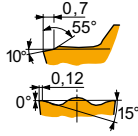

M geometri, kanal açma ve çap tornalama için, darbesizden darbeli kesime kadar uygun.

LCMF 031602-M	T8330	0.2	160	0.13	1.0	95	0.12	1.0	150	0.13	1.0	-	-	-	30	0.15	1.0
LCMF 031604-M	T8330	0.4	170	0.13	1.0	100	0.12	1.0	160	0.13	1.0	-	-	-	30	0.15	1.0
LCMF 041604-M	T8330	0.4	155	0.18	1.0	90	0.16	1.0	145	0.18	1.0	-	-	-	30	0.15	1.0
	T9325	0.4	225	0.18	1.0	135	0.16	1.0	210	0.18	1.0	-	-	-	-	-	-
LCMF 041608-M	T8330	0.8	185	0.18	1.0	110	0.16	1.0	175	0.18	1.0	-	-	-	35	0.15	1.0
	T9325	0.8	265	0.18	1.0	155	0.16	1.0	250	0.18	1.0	-	-	-	-	-	-
LCMF 051608-M	T8330	0.8	180	0.20	1.0	105	0.18	1.0	170	0.20	1.0	-	-	-	35	0.15	1.0
	T9325	0.8	255	0.20	1.0	150	0.18	1.0	240	0.20	1.0	-	-	-	-	-	-
LCMF 061608-M	T8330	0.8	175	0.25	1.0	105	0.23	1.0	165	0.25	1.0	-	-	-	35	0.15	1.0
	T9325	0.8	230	0.25	1.0	135	0.23	1.0	215	0.25	1.0	-	-	-	-	-	-

LCMF 16, LCMF 30 - MP

PRAMET

	CW	CWTOLL	CWTOLU	INSL
	(mm)	(mm)	(mm)	(mm)
0316	3.00	-0.05	0.05	17.5
0416	4.00	-0.05	0.05	17.6
0516	5.00	-0.05	0.05	18.3
0616	6.00	-0.05	0.05	18.5
0830	8.00	-0.05	0.05	30.9

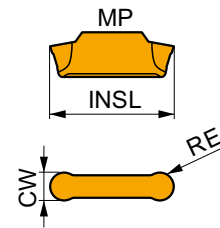

Kesme hızı (vc), ilerleme (f) ve kesme derinliği (ap) için uygunluk ve başlangıç değerleri. Daha ileri hesaplamalar için İşleme Hesaplayıcısı uygulamasına başvurun.

Product	RE	P			M			K			N			S			H		
		vc	f	ap	vc	f	ap	vc	f	ap	vc	f	ap	vc	f	ap			
	(mm)	(m/min)	(mm/rev)	(mm)	(m/min)	(mm/rev)	(mm)	(m/min)	(mm/rev)	(mm)	(m/min)	(mm/rev)	(mm)	(m/min)	(mm/rev)	(mm)	(m/min)	(mm/rev)	(mm)

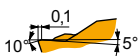

MP geometri, kopya profil ve çap tornalama, ve darbesizden darbeli kesime kadar uygun.

LCMF 0316M0-MP	T8330	1.5	190	0.30	0.8	110	0.27	0.8	180	0.30	0.8	-	-	-	-	-	-
LCMF 0416M0-MP	T8330	2.0	175	0.40	1.0	105	0.36	1.0	165	0.40	1.0	-	-	-	-	-	-
	T9325	2.0	220	0.40	1.0	130	0.36	1.0	205	0.40	1.0	-	-	-	-	-	-
LCMF 0516M0-MP	T8330	2.5	170	0.45	1.0	100	0.41	1.0	160	0.45	1.0	-	-	-	-	-	-
	T9325	2.5	205	0.45	1.0	120	0.41	1.0	190	0.45	1.0	-	-	-	-	-	-



Kesme hızı (vc), ilerleme (f) ve kesme derinliği (ap) için uygunluk ve başlangıç değerleri. Daha ileri hesaplamalar için İşleme Hesaplayıcısı uygulamasına başvurun.

Product	RE (mm)	P			M			K			N			S			H		
		vc (m/min)	f (mm/rev)	ap (mm)	vc (m/min)	f (mm/rev)	ap (mm)	vc (m/min)	f (mm/rev)	ap (mm)	vc (m/min)	f (mm/rev)	ap (mm)	vc (m/min)	f (mm/rev)	ap (mm)	vc (m/min)	f (mm/rev)	ap (mm)

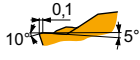

MP geometri, kopya profil ve çap tormalama, ve darbesizden darbeli kesime kadar uygun.

LCMF 0616MO-MP	T8330	3.0	165	0.50	1.0	95	0.45	1.0	155	0.50	1.0	-	-	-	-	-	-	-
	T9325	3.0	200	0.50	1.0	120	0.45	1.0	190	0.50	1.0	-	-	-	-	-	-	-
LCMF 0830MO-MP	T8330	4.0	150	0.60	1.2	90	0.54	1.2	140	0.60	1.2	-	-	-	-	-	-	-

LCMR 16 - CM

PRAMET

	CW (mm)	CWTOLL (mm)	CWTOLU (mm)	INSL (mm)
0316	3.00	-0.05	0.05	16.4
0416	4.00	-0.05	0.05	16.4

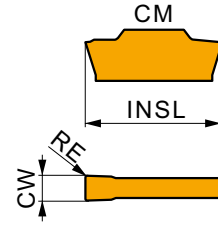

Kesme hızı (vc), ilerleme (f) için uygunluk ve başlangıç değerleri. Daha ileri hesaplamalar için İşleme Hesaplayıcısı uygulamasına başvurun.

Product	RE (mm)	P		M		K		N		S		H		PSIRR (°)	PSIRL (°)
		vc (m/min)	f (mm/rev)	vc (m/min)	f (mm/rev)	vc (m/min)	f (mm/rev)	vc (m/min)	f (mm/rev)	vc (m/min)	f (mm/rev)	vc (m/min)	f (mm/rev)		

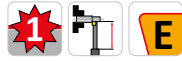

CM geometri, kesme ve kanal açma için ilk tercih, darbesizden hafif darbeli kesmeye kadar uygun.

LCMR 031602-CM	T8330	0.2	130	0.11	75	0.10	120	0.11	-	-	-	-	-	-
LCMR 041604-CM	T8330	0.4	130	0.11	75	0.10	120	0.11	-	-	-	-	-	-



LCMR 16, LCMR 30 - F

PRAMET

	CW	CWTOLL	CWTOLU	INSL
	(mm)	(mm)	(mm)	(mm)
0316	3.00	-0.05	0.05	16.4
0416	4.00	-0.05	0.05	16.4
0516	5.00	-0.05	0.05	16.4
0616	6.00	-0.05	0.05	16.4
0830	8.00	-0.05	0.05	30.0

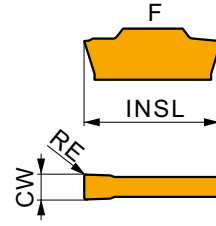

Kesme hızı (vc), ilerleme (f) ve kesme derinliği (ap) için uygunluk ve başlangıç değerleri. Daha ileri hesaplamalar için İşleme Hesaplayıcısı uygulamasına başvurun.

Product	RE	P			M			K			N			S			H		
		vc	f	ap	vc	f	ap	vc	f	ap	vc	f	ap	vc	f	ap			
	(mm)	(m/min)	(mm/rev)	(mm)	(m/min)	(mm/rev)	(mm)	(m/min)	(mm/rev)	(mm)	(m/min)	(mm/rev)	(mm)	(m/min)	(mm/rev)	(mm)	(m/min)	(mm/rev)	(mm)

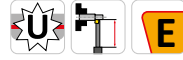
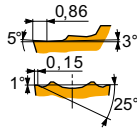

F geometri, kesme, kanal açma ve çap tornalama için, ince ve finiş işleme, ve darbesizden hafif darbeli işlemeye kadar uygun.

LCMR 031604-F	T8330	0.4	200	0.10	0.5	120	0.09	0.5	190	0.10	0.5	-	-	-	-	-	-	-	-
LCMR 041604-F	T8330	0.4	185	0.13	0.5	110	0.12	0.5	175	0.13	0.5	-	-	-	-	-	-	-	-
LCMR 051604-F	T8330	0.4	180	0.15	0.5	105	0.14	0.5	170	0.15	0.5	-	-	-	-	-	-	-	-
LCMR 061608-F	T8330	0.8	190	0.17	1.0	110	0.15	1.0	180	0.17	1.0	-	-	-	-	-	-	-	-

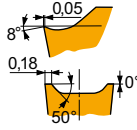

F geometri, kesme, kanal açma ve çap tornalama için, ince ve finiş işleme, ve darbesizden hafif darbeli işlemeye kadar uygun.

LCMR 083008-F	T8330	0.8	175	0.25	1.0	105	0.23	1.0	165	0.25	1.0	-	-	-	-	-	-	-	-
---------------	-------	-----	-----	------	-----	-----	------	-----	-----	------	-----	---	---	---	---	---	---	---	---

LCMR 16 - M

PRAMET

	CW	CWTOLL	CWTOLU	INSL
	(mm)	(mm)	(mm)	(mm)
0316	3.00	-0.05	0.05	16.4
0416	4.00	-0.05	0.05	16.4
0516	5.00	-0.05	0.05	16.4
0616	6.00	-0.05	0.05	16.4

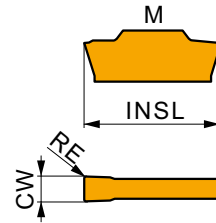

Kesme hızı (vc), ilerleme (f) ve kesme derinliği (ap) için uygunluk ve başlangıç değerleri. Daha ileri hesaplamalar için İşleme Hesaplayıcısı uygulamasına başvurun.

Product	RE	P			M			K			N			S			H		
		vc	f	ap	vc	f	ap	vc	f	ap	vc	f	ap	vc	f	ap			
	(mm)	(m/min)	(mm/rev)	(mm)	(m/min)	(mm/rev)	(mm)	(m/min)	(mm/rev)	(mm)	(m/min)	(mm/rev)	(mm)	(m/min)	(mm/rev)	(mm)	(m/min)	(mm/rev)	(mm)

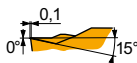
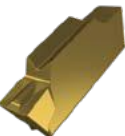

M geometri, kanal açma ve çap tornalama için, darbesizden darbeli kesime kadar uygun.

LCMR 031604-M	T8330	0.4	170	0.13	1.0	100	0.12	1.0	160	0.13	1.0	-	-	-	-	-	-	30	0.15	1.0
LCMR 041604-M	T8330	0.4	155	0.18	1.0	90	0.16	1.0	145	0.18	1.0	-	-	-	-	-	-	30	0.15	1.0
LCMR 051604-M	T8330	0.4	150	0.20	1.0	90	0.18	1.0	140	0.20	1.0	-	-	-	-	-	-	30	0.15	1.0
LCMR 061608-M	T8330	0.8	175	0.25	1.0	105	0.23	1.0	165	0.25	1.0	-	-	-	-	-	-	35	0.15	1.0



LCMR 16 - MP

PRAMET

	CW	CWTOLL	CWTOLU	INSL
	(mm)	(mm)	(mm)	(mm)
0316	3.00	-0.05	0.05	17.4
0416	4.00	-0.05	0.05	17.5
0516	5.00	-0.05	0.05	18.1
0616	6.00	-0.05	0.05	18.3

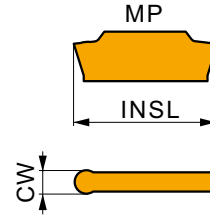

Kesme hızı (vc), ilerleme (f) ve kesme derinliği (ap) için uygunluk ve başlangıç değerleri. Daha ileri hesaplamalar için İşleme Hesaplayıcısı uygulamasına başvurun.

Product	RE	P			M			K			N			S			H		
		vc	f	ap	vc	f	ap	vc	f	ap	vc	f	ap	vc	f	ap	vc	f	ap
	(mm)	(m/min)	(mm/rev)	(mm)	(m/min)	(mm/rev)	(mm)	(m/min)	(mm/rev)	(mm)	(m/min)	(mm/rev)	(mm)	(m/min)	(mm/rev)	(mm)	(m/min)	(mm/rev)	(mm)



MP geometri, kopya profil ve çap tornalama, ve darbesizden darbeli kesime kadar uygun.

LCMR 0316MO-MP	T8330	1.5	190	0.30	0.8	110	0.27	0.8	180	0.30	0.8	-	-	-	-	-	-	-	-
LCMR 0416MO-MP	T8330	2.0	175	0.40	1.0	105	0.36	1.0	165	0.40	1.0	-	-	-	-	-	-	-	-
LCMR 0516MO-MP	T8330	2.5	170	0.45	1.0	100	0.41	1.0	160	0.45	1.0	-	-	-	-	-	-	-	-
LCMR 0616MO-MP	T8330	3.0	165	0.50	1.0	95	0.45	1.0	155	0.50	1.0	-	-	-	-	-	-	-	-



GFI(RL) EXT

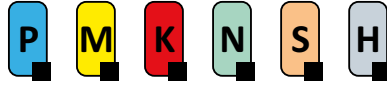

PRAMET

G

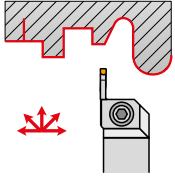



LCM. Uç için V-Kanal Sıkmalı Dış Torna ve Kanal Kateri

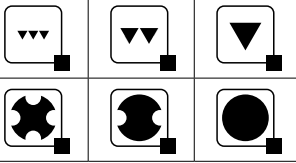
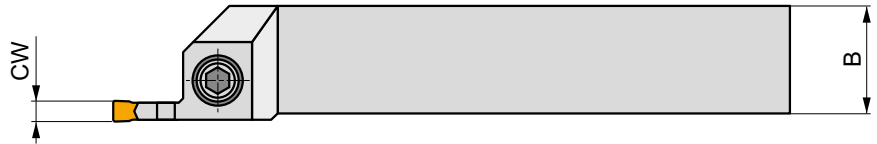
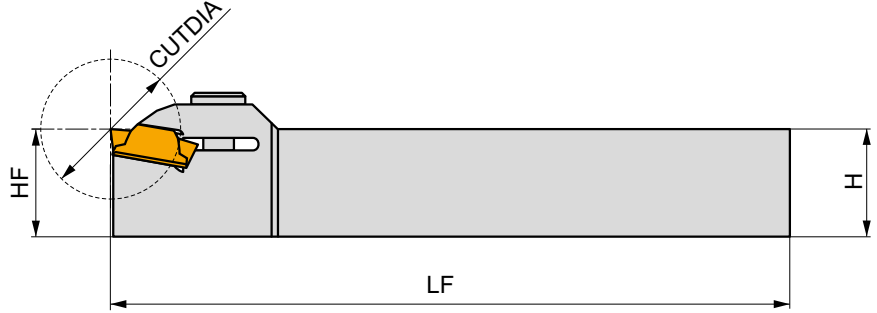





LCM. 0316, 0416, 0516, 0616 veya 0830 uçlar için Sağ/Sol dış kanal kateri. Ø48mm çapa kadar kesme ile kanal açma profil işleme ve çap tornalama için uygundur. 16x16-32x25 shaft ölçülerinde bulunur. Gövde uzun takım ömrü için işlem görmüştür.



Product	≡	H	B	L	CW	CUTDIA	kg			
	(mm)	(mm)	(mm)	(mm)	(mm)	(mm)				
R	GFIR 1616 H 03	16	16	16	100	3.00	18	0.22	G1136	GL03
	GFIR 2020 K 03	20	20	20	125	3.00	18	0.40	G1136	GL04
	GFIR 2525 M 03	25	25	25	150	3.00	18	0.73	G1136	GL05
	GFIR 1616 H 04	16	16	16	100	4.00	24	0.22	G1137	GL03
	GFIR 2020 K 04	20	20	20	125	4.00	24	0.38	G1137	GL04
	GFIR 2525 M 04	25	25	25	150	4.00	24	0.67	G1137	GL05
	GFIR 2020 K 05	20	20	20	125	5.00	28	0.38	G1138	GL04
	GFIR 2525 M 05	25	25	25	150	5.00	28	0.70	G1138	GL05
	GFIR 2020 K 06	20	20	20	125	6.00	28	0.38	G1139	GL04
	GFIR 2525 M 06	25	25	25	150	6.00	28	0.70	G1139	GL05
	GFIR 2525 M 08	25	25	25	150	8.00	48	0.74	G1193	GL09
	GFIR 3225 P 08	32	32	25	170	8.00	48	1.03	G1193	GL09
L	GFIL 1616 H 03	16	16	16	100	3.00	18	0.22	G1136	GL03
	GFIL 2020 K 03	20	20	20	125	3.00	18	0.39	G1136	GL04
	GFIL 2525 M 03	25	25	25	150	3.00	18	0.73	G1136	GL05
	GFIL 1616 H 04	16	16	16	100	4.00	24	0.20	G1137	GL03
	GFIL 2020 K 04	20	20	20	125	4.00	24	0.38	G1137	GL04
	GFIL 2525 M 04	25	25	25	150	4.00	24	0.69	G1137	GL05
	GFIL 2020 K 05	20	20	20	125	5.00	28	0.38	G1138	GL04
	GFIL 2525 M 05	25	25	25	150	5.00	28	0.71	G1138	GL05
	GFIL 2020 K 06	20	20	20	125	6.00	28	0.40	G1139	GL04
	GFIL 2525 M 06	25	25	25	150	6.00	28	0.70	G1139	GL05
	GFIL 2525 M 08	25	25	25	150	8.00	48	0.75	G1193	GL09
	GFIL 3225 P 08	32	32	25	170	8.00	48	1.03	G1193	GL09



	
GI136	LCM. 0316..
GI137	LCM. 0416..
GI138	LCM. 0516..
GI139	LCM. 0616..
GI193	LCM. 0830..

		 Nm			
GL03	HS 0616C	6.0	M 6	16	HXX 5
GL04	HS 0620C	6.0	M 6	20	HXX 5
GL05	HS 0625C	6.0	M 6	25	HXX 5
GL09	HSI 1020	8.0	M 10	20	HXX 8



GFM(RL) EXT

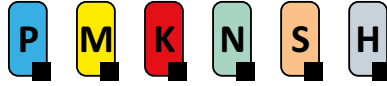

PRAMET

G



LCM. Uç için V-Kanal Sıkmalı Dış Torna ve Kanal Kateri

LCM. 0316, 0416, 0516, 0616 veya 0830 uçlar için Sağ/Sol dış kanal kateri. Ø30-80mm çap aralığında kesme ile kanal açma profil işleme ve çap tormalama için uygundur. 20x20-32x25 şaft ölçülerinde bulunur. Gövde uzun takım ömrü için işlem görmüştür.

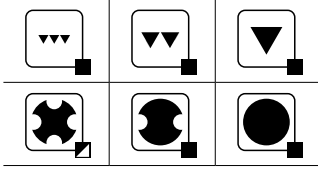
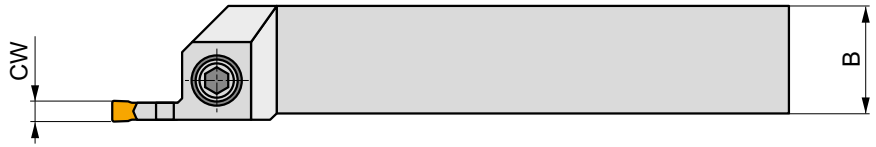
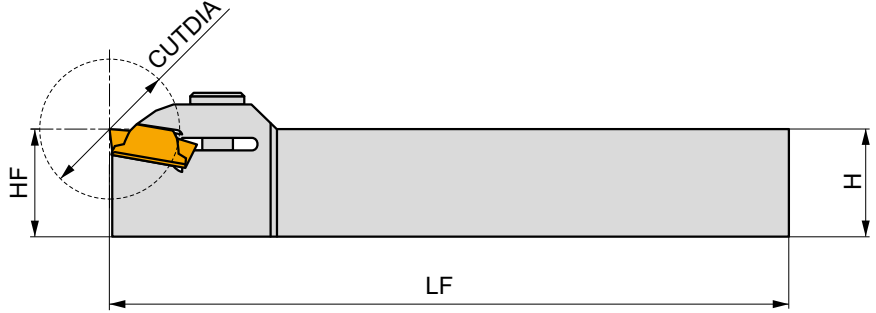
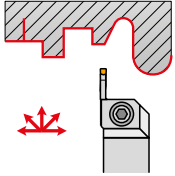

Product	HF	H	B	LF	CW	CUTDIA	kg			
	(mm)	(mm)	(mm)	(mm)	(mm)	(mm)				
R	GFMR 2020 K 0316	20	20	20	125	3.00	30	0.37	GI136	GL04
	GFMR 2525 M 0316	25	25	25	150	3.00	30	0.68	GI136	GL04
	GFMR 2020 K 0416	20	20	20	125	4.00	40	0.38	GI137	GL04
	GFMR 2525 M 0416	25	25	25	150	4.00	40	0.68	GI137	GL04
	GFMR 2525 M 0516	25	25	25	150	5.00	50	0.67	GI138	GL04
	GFMR 3225 P 0516	32	32	25	170	5.00	50	0.97	GI138	GL04
	GFMR 2525 M 0616	25	25	25	150	6.00	60	0.66	GI139	GL04
	GFMR 3225 P 0616	32	32	25	170	6.00	60	0.97	GI139	GL04
	GFMR 3225 P 0830	32	32	25	170	8.00	80	0.97	GI193	GL10
L	GFML 2020 K 0316	20	20	20	125	3.00	30	0.24	GI136	GL04
	GFML 2525 M 0316	25	25	25	150	3.00	30	0.70	GI136	GL04
	GFML 2020 K 0416	20	20	20	125	4.00	40	0.37	GI137	GL04
	GFML 2525 M 0416	25	25	25	150	4.00	40	0.69	GI137	GL04
	GFML 2525 M 0516	25	25	25	150	5.00	50	0.64	GI138	GL04
	GFML 3225 P 0516	32	32	25	170	5.00	50	0.97	GI138	GL04
	GFML 2525 M 0616	25	25	25	150	6.00	60	0.64	GI139	GL04
	GFML 3225 P 0616	32	32	25	170	6.00	60	0.95	GI139	GL04
	GFML 3225 P 0830	32	32	25	170	8.00	80	0.99	GI193	GL10



GI136	LCM. 0316..
GI137	LCM. 0416..
GI138	LCM. 0516..
GI139	LCM. 0616..
GI193	LCM. 0830..



GL04	HS 0620C	6.0	M 6	20	HXK 5
GL10	HSI 1020	8.0	M 10	20	HXK 8



XLCCN B

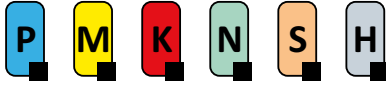

PRAMET



LCM. Uçlar için Çift Taraflı Kesme Laması

60mm derinlik ya da Ø120mm çapa kadar kesme işlemleri için lama. Tek ya da çift taraflı LCM. uçlar için. 26 ve 32mm yüksekliklerinde. DU Pramet baz tutuculara uygundur. Lama uzun takım ömrü için işlem görmüştür.

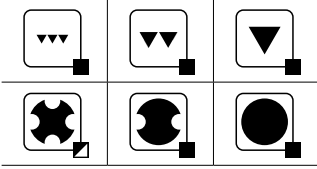
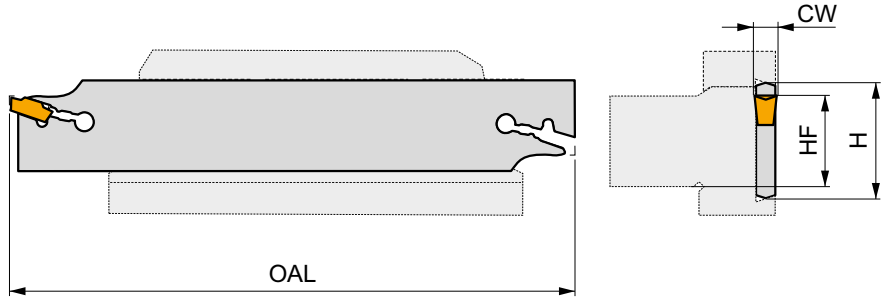
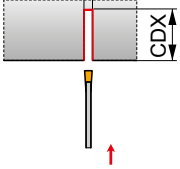

Product	≡ (mm)	H (mm)	L (mm)	CW (mm)	CDX (mm)	kg		
N XLCCN 2602 J 0316	21.4	26	110	3.00	35	0.09	G136	KV1
XLCCN 3202 M 0316	25	32	150	3.00	50	0.13	G136	KV1
XLCCN 3203 M 0416	25	32	150	4.00	50	0.15	G137	KV1
XLCCN 3204 M 0516	25	32	150	5.00	60	0.18	G138	KV1
XLCCN 3205 M 0616	25	32	150	6.00	60	0.17	G139	KV1



G136

LCM. 0316..

G137

LCM. 0416..

G138

LCM. 0516..

G139

LCM. 0616..



KV1



KV 5x100



DU, D

PRAMET



Kesme Lamaları için Takım Tutucu

GL veya XLC. lamalar için tutucu. 20x20-40x40mm şaft ölçülerinde bulunur. Gövde uzun takım ömrü için işlem görmüştür.

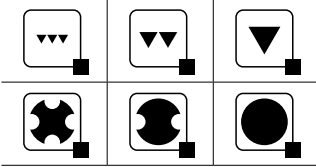
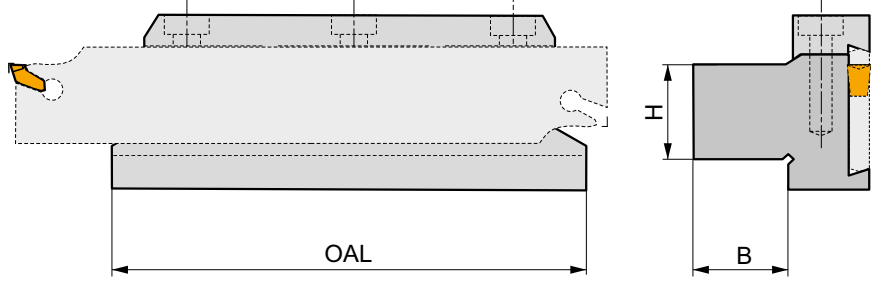
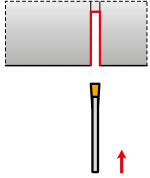

Product	H (mm)	B (mm)	OAL (mm)	kg		
26-DU 2020	20	20	90	0.70	GI007	ND2
26-D 2020	20	20	100	0.82	GI007	ND2
32-DU 2523	25	23	110	1.02	GI008	ND2
32-DU 2532	25	32	110	1.10	GI008	ND2
32-DU 3229	32	29	110	1.25	GI008	ND2
32-D 2530	25	30	115	1.30	GI008	ND2
45-DU 3229	32	29	110	1.50	GI009	ND7
45-DU 4036	40	36	110	2.05	GI009	ND7
47-D 4040	40	40	150	3.88	GI091	ND3

GI007	XLC.N 26..	GL.-S26.B
GI008	XLC.N 32..	GL.-S32.B
GI009	XLC.N 45..	-
GI091	XLC.N 47..	-

ND2	HS 0625	6.0	M 6	25	HXK 5
ND3	HS 1030	8.0	M 10	30	HXK 8
ND7	HS 0630	6.0	M 6	30	HXK 5



XLCCN 25 BS



PRAMET

G



Modüler LCM. Uçlu MS-EN Takım için Radyal Kanal Açma Laması

Tek veya çift taraflı LCM. 0316, 0416, 0516 veya 0616 uçlar için modüler kanal açma laması. Kanal açma ve kesme (maks. 25mm kesme derinliği) uygulamaları için uygundur. MS-EN tutucu ile kullanılır. Lamalar uzun takım ömrü için işlem görmüştür.

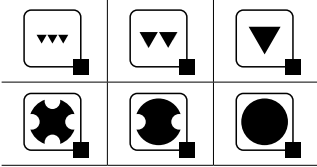
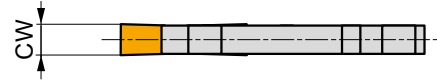
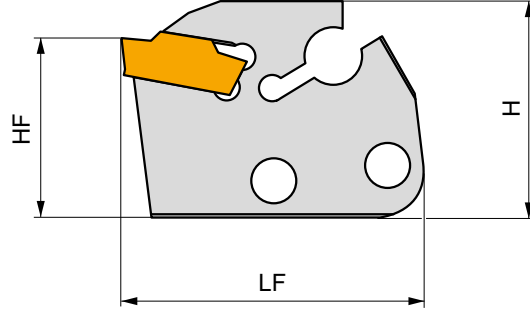
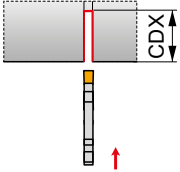

Product	≡	H	LF	CW	CDX	kg		
	(mm)	(mm)	(mm)	(mm)	(mm)			
N XLCCN 250215-0316	24	29	40	3.00	15	0.01	G136	-
XLCCN 250225-0316	24	29	50	3.00	25	0.02	G136	-
XLCCN 250315-0416	24	29	40	4.00	15	0.04	G137	-
XLCCN 250325-0416	24	29	50	4.00	25	0.04	G137	-
XLCCN 250425-0516	24	29	50	5.00	25	0.03	G138	-
XLCCN 250525-0616	24	29	50	6.00	25	0.04	G139	-



G136
G137
G138
G139

LCM. 0316..
LCM. 0416..
LCM. 0516..
LCM. 0616..

MS-EN



XLCCN, XLCF(NRL) veya XLFL Kanal Laması için Modüler Takım Tutucu

XLCCN, XLCF(NRL) veya XLFL Kanal Laması için Modüler Takım Tutucu. 12x12-32x25mm şaft ölçülerinde bulunur. Gövde uzun takım ömrü için işlem görmüştür.

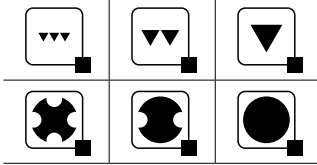
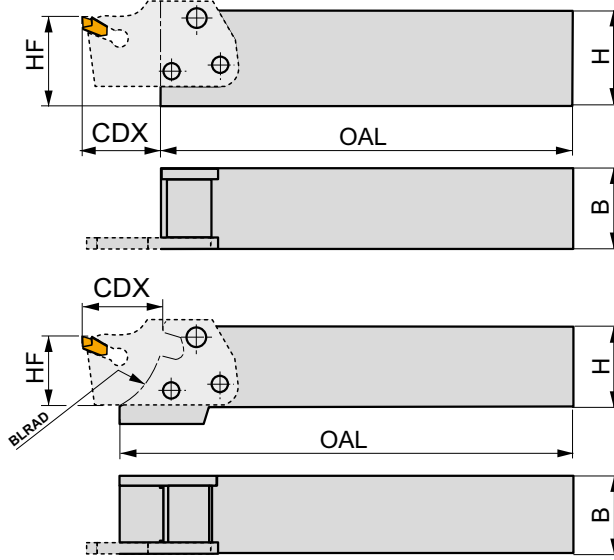
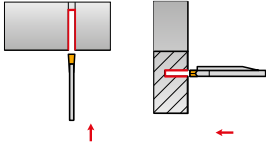

Product	HF (mm)	H (mm)	B (mm)	OAL (mm)	CDX (mm)	BLRAD (mm)	kg	GI	ND
MS-EN-1212 F	12	12	12	75	15	-	0.13	GI006	ND4
MS-EN-1616 H	16	16	16	90	15	-	0.21	GI006	ND4
MS-EN-2020 K	20	20	20	115	15	-	0.23	GI003	ND5
MS-EN-2020 KS	20	20	20	129	15	25	0.42	GI060	ND5
MS-EN-2525 M	25	25	25	140	15	-	0.65	GI003	ND5
MS-EN-2525 MS	25	25	25	153	15	25	0.74	GI060	ND5
MS-EN-3225 P	32	32	25	160	15	-	0.95	GI003	ND5
MS-EN-3225 PS	32	32	25	174	15	25	1.00	GI060	ND5

GI	Product	Product	Product
GI003	XLCCN 25..15...	XLXFL 25...	XLCCN 25..25...
GI006	XLCF 16..15...	XLCF 16..20...	-
GI060	XLCCN 25..15...	XLCCN 25..25...	-

ND	Product	Nm	Product	Product	Product	Nm	Product	Product	Product
ND4	US 4011-T15P	3.5	M 4	10.6	-	-	-	-	FLAG T15P
ND5	US 45013-T20P	5.0	M 5	13	US 46017-T20P	5.0	M6	17	FLAG T15P

ND4 = 3 x US 4011-T15P; ND5 = 2 x US 45013-T20P



GFIL-L AXIAL



PRAMET

G



LCM. 03 Uç için V-Kanal Sıkmalı Dış Aksiyel Kanal Açma Dış Kateri

Tek veya çift taraflı LCM. 0313 ya da 0316 uçlar için sol kesme yönlü aksiyel kanal açma dış kateri. Aksiyel kanal açma, aksiyel profil işleme veya kanal genişletme. Ø17-170mm ve 9mm maksimum kesme derinliği. 25x25mm şaft ölçüleri. Gövde uzun takım ömrü için işlem görmüştür.

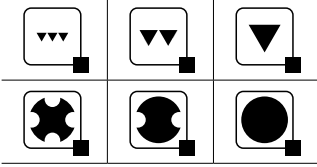
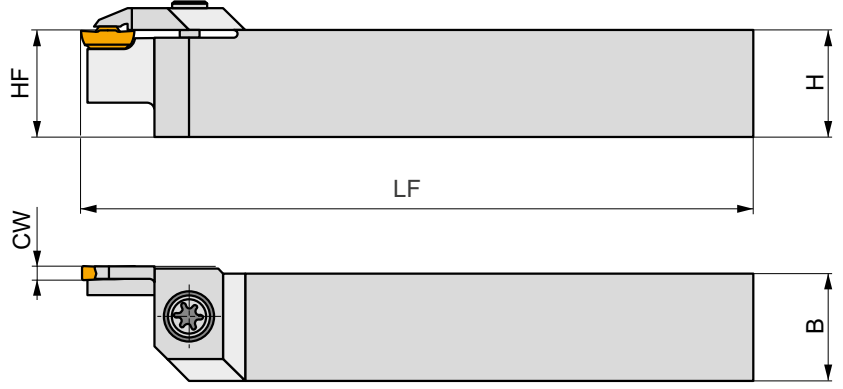
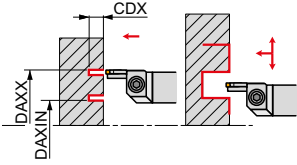

Product	HF	H	B	LF	CW	CDX	DAXIN	DAXX	kg	G1136	G1143
	(mm)	(mm)	(mm)	(mm)	(mm)	(mm)	(mm)				
GFIL 2525 M 0313L 030017	25	25	25	150	3.00	9	17	30	0.64	G1143	GL02
GFIL 2525 M 0313L 039024	25	25	25	150	3.00	9	24	39	0.66	G1143	GL07
GFIL 2525 M 0313L 050033	25	25	25	150	3.00	9	33	50	0.67	G1143	GL07
GFIL 2525 M 0313L 060043	25	25	25	150	3.00	9	43	60	0.67	G1143	GL07
GFIL 2525 M 0313L 076053	25	25	25	150	3.00	9	53	76	0.67	G1143	GL07
GFIL 2525 M 0316L 100070	25	25	25	150	3.00	9	70	100	0.69	G1136	GL07
GFIL 2525 M 0316L 130090	25	25	25	150	3.00	9	90	130	0.70	G1136	GL07
GFIL 2525 M 0316L 170110	25	25	25	150	3.00	9	110	170	0.71	G1136	GL07



G1136
G1143

LCM. 0316..
LCM. 0313..



GL02
GL07

US 5015-T20P
US 5018-T20P

5.0
5.0

M 5
M 5

15
18.2

FLAG T20P
FLAG T20P



GFIL-R AXIAL

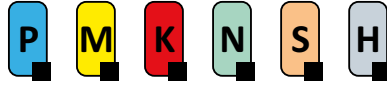

PRAMET

G



LCM. 03 veya 04 Uç için V-Kanal Sıkmalı Dış Aksiyel Kanal Kateri

Tek veya çift taraflı LCM. 0313, 0316, 0413 ya da 0416 uçlar için sol kesme yönlü aksiyel kanal açma dış kateri. Aksiyel kanal açma, aksiyel profil işleme veya kanal genişletme. Ø17-230mm ve 12mm maksimum kesme derinliği. 25x25mm şaft ölçüleri. Gövde uzun takım ömrü için işlem görmüştür.

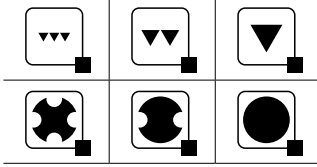
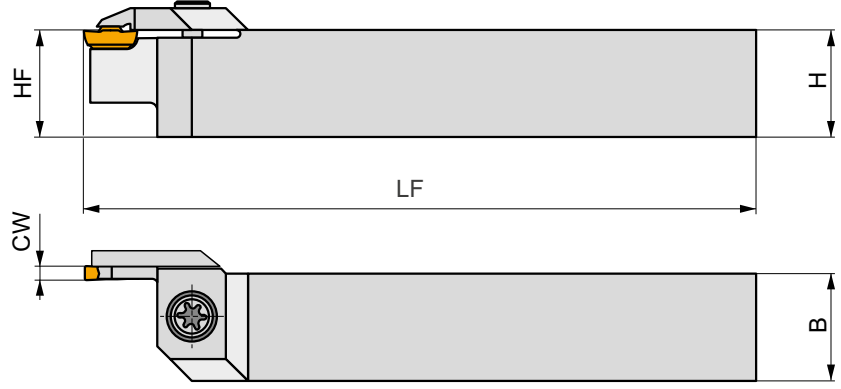
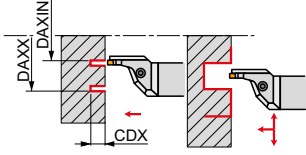

Product	HF	H	B	LF	CW	CDX	DAXIN	DAXX	kg		
	(mm)	(mm)	(mm)	(mm)	(mm)	(mm)	(mm)	(mm)			
L GFIL 2525 M 03R 030017-A	25	25	25	150	3.00	9	17	30	0.69	G1143	GL07
GFIL 2525 M 03R 039024-A	25	25	25	150	3.00	9	24	39	0.69	G1143	GL07
GFIL 2525 M 03R 050033-A	25	25	25	150	3.00	9	33	50	0.72	G1143	GL07
GFIL 2525 M 03R 060043-A	25	25	25	150	3.00	9	43	60	0.69	G1143	GL07
GFIL 2525 M 03R 076053-A	25	25	25	150	3.00	9	53	76	0.68	G1143	GL07
GFIL 2525 M 03R 100070-A	25	25	25	150	3.00	9	70	100	0.79	G1136	GL08
GFIL 2525 M 03R 130090-A	25	25	25	150	3.00	9	90	130	0.73	G1136	GL08
GFIL 2525 M 03R 170110-A	25	25	25	150	3.00	9	110	170	0.76	G1136	GL08
GFIL 2525 M 04R 030017-A	25	25	25	150	3.00	9	17	30	0.71	G1170	GL07
GFIL 2525 M 04R 034021-A	25	25	25	150	4.00	9	21	34	0.69	G1170	GL07
GFIL 2525 M 04R 040026-A	25	25	25	150	4.00	11	26	40	0.00	G1170	GL07
GFIL 2525 M 04R 050032-A	25	25	25	150	4.00	11	32	50	0.68	G1170	GL07
GFIL 2525 M 04R 060042-A	25	25	25	150	4.00	11	42	60	0.66	G1170	GL07
GFIL 2525 M 04R 075052-A	25	25	25	150	4.00	11	52	75	0.67	G1170	GL07
GFIL 2525 M 04R 100070-A	25	25	25	150	4.00	12	70	100	0.75	G1137	GL08
GFIL 2525 M 04R 130090-A	25	25	25	150	4.00	12	90	130	0.75	G1137	GL08
GFIL 2525 M 04R 170110-A	25	25	25	150	4.00	12	110	170	0.75	G1137	GL08
GFIL 2525 M 04R 230140-A	25	25	25	150	4.00	12	140	230	0.78	G1137	GL08



G1136

LCM. 0316..

G1137

LCM. 0416..

G1143

LCM. 0313..

G1170

LCM. 0413..



GL07

US 5018-T20P

5.0

M 5

18.2

FLAG T20P

-

GL08

US 6020-T25P

6.0

M 6

20.2

-

SDRT25P



GFIR-L AXIAL

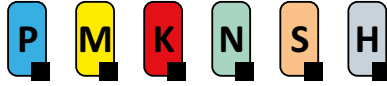

PRAMET

G



LCM. 03/04 Uç için V-Kanal Sıkmalı Dış Kanal Kateri

LCM. 0313, 0316, 0413 veya 0416 uçlar için sağ aksiyel dış kanal kateri. Ø17-230mm çap aralığında 12mm aralığında aksiyel kanal açma, aksiyel profil işleme ve kanal genişletme için uygundur. 25x25 şaft ölçülerinde bulunur. Uzun takım ömrü ve düşük titreşim için güçlendirilmiş gövde. Gövde uzun takım ömrü için işlem görmüştür.

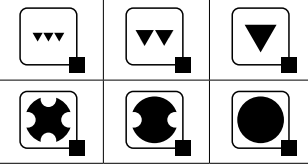
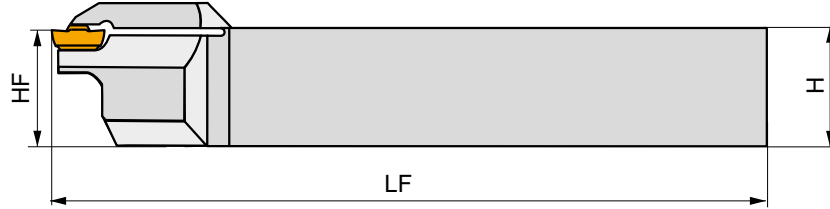
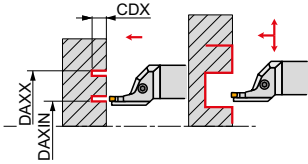

Product	≡	H	B	LF	CW	CDX	DAXIN	DAXX	kg		
	(mm)	(mm)	(mm)	(mm)	(mm)	(mm)	(mm)	(mm)			
GFIR 2525 M 03L 030017-A	25	25	25	150	3.00	9	17	30	0.65	G143	GL07
GFIR 2525 M 03L 039024-A	25	25	25	150	3.00	9	24	39	0.68	G143	GL07
GFIR 2525 M 03L 050033-A	25	25	25	150	3.00	9	33	50	0.65	G143	GL07
GFIR 2525 M 03L 060043-A	25	25	25	150	3.00	9	43	60	0.68	G143	GL07
GFIR 2525 M 03L 076053-A	25	25	25	150	3.00	9	53	76	0.69	G143	GL07
GFIR 2525 M 03L 100070-A	25	25	25	150	3.00	9	70	100	0.75	G136	GL08
GFIR 2525 M 03L 130090-A	25	25	25	150	3.00	9	90	130	0.76	G136	GL08
GFIR 2525 M 03L 170110-A	25	25	25	150	3.00	9	110	170	0.68	G136	GL08
GFIR 2525 M 04L 030017-A	25	25	25	150	3.00	9	17	30	0.68	G170	GL07
GFIR 2525 M 04L 034021-A	25	25	25	150	4.00	9	21	34	0.68	G170	GL07
GFIR 2525 M 04L 040026-A	25	25	25	150	4.00	11	26	40	0.68	G170	GL07
GFIR 2525 M 04L 050032-A	25	25	25	150	4.00	11	32	50	0.66	G170	GL07
GFIR 2525 M 04L 060042-A	25	25	25	150	4.00	11	42	60	0.69	G170	GL07
GFIR 2525 M 04L 075052-A	25	25	25	150	4.00	11	52	75	0.67	G170	GL07
GFIR 2525 M 04L 100070-A	25	25	25	150	4.00	12	70	100	0.72	G137	GL08
GFIR 2525 M 04L 130090-A	25	25	25	150	4.00	12	90	130	0.75	G137	GL08
GFIR 2525 M 04L 170110-A	25	25	25	150	4.00	12	110	170	0.72	G137	GL08
GFIR 2525 M 04L 230140-A	25	25	25	150	4.00	12	140	230	0.79	G137	GL08



G136
G137
G143
G170

LCM. 0316..
LCM. 0416..
LCM. 0313..
LCM. 0413..



GL07
GL08

US 5018-T20P
US 6020-T25P

5.0
6.0

M 5
M 6

18.2
20.2

FLAG T20P
-

-
SDRT25P



GFIR-R AXIAL

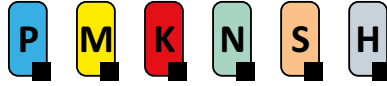

PRAMET

G



LCM. 03 Uç için V-Kanal Sıkmalı Dış Kanal Kateri

LCM. 0313 veya 0316 uçlar için sağ aksiyel dış kanal kateri. Ø17-70mm çap aralığında, 9mm derinliğinde aksiyel kanal açma, aksiyel profil işleme ve kanal genişletme için uygundur. 20x20-32x25 şaft ölçülerinde bulunur. Uzun takım ömrü ve düşük titreşim için güçlendirilmiş gövde. Gövde uzun takım ömrü için işlem görmüştür.

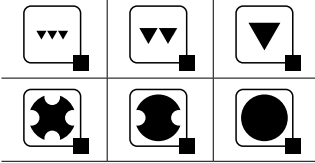
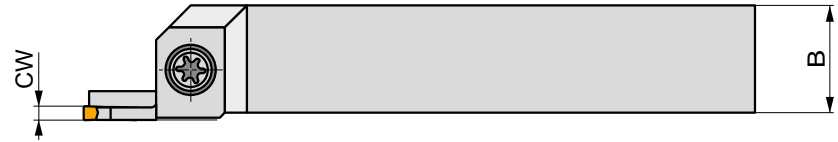
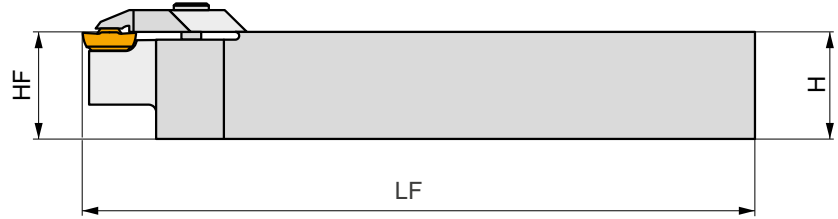
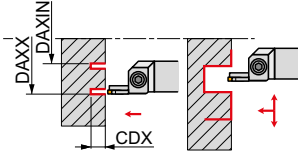

Product	Hf	H	B	Lf	CW	CDX	DAXIN	DAXX	kg	GI	GL
	(mm)	(mm)	(mm)	(mm)	(mm)	(mm)	(mm)	(mm)			
R GFIR 2525 M 0313R 030017	25	25	25	150	3.00	9	17	30	0.65	GI143	GL02
GFIR 2525 M 0313R 039024	25	25	25	150	3.00	9	24	39	0.66	GI143	GL07
GFIR 2525 M 0313R 050033	25	25	25	150	3.00	9	33	50	0.68	GI143	GL07
GFIR 2525 M 0313R 060043	25	25	25	150	3.00	9	43	60	0.68	GI143	GL07
GFIR 2525 M 0313R 076053	25	25	25	150	3.00	9	53	76	0.68	GI143	GL07
GFIR 2525 M 0316R 100070	25	25	25	150	3.00	9	70	100	0.69	GI136	GL07
GFIR 2525 M 0316R 130090	25	25	25	150	3.00	9	90	130	0.70	GI136	GL07
GFIR 2525 M 0316R 170110	25	25	25	150	3.00	9	110	170	0.70	GI136	GL07



GI136
GI143

LCM. 0316..
LCM. 0313..



GL02
GL07

US 5015-T20P
US 5018-T20P

5.0
5.0

M 5
M 5

15
18.2

FLAG T20P
FLAG T20P



GFML-L AXIAL



PRAMET

G



LCM. 04 Uç için V-Kanal Sıkmalı Dış Aksiyel Kanal Açma Dış Kateri

Tek veya çift taraflı LCM. 0413 ya da 0416 uçlar için sol kesme yönlü aksiyel kanal açma dış kateri. Derin aksiyel kanal açma, aksiyel profil işleme veya kanal genişletme. Ø17-230mm ve 20mm maksimum kesme derinliği. 25x25mm şaft ölçüleri. Gövde uzun takım ömrü için işlem görmüştür.

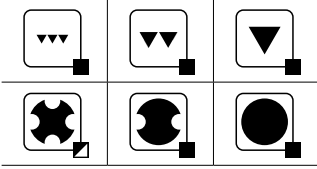
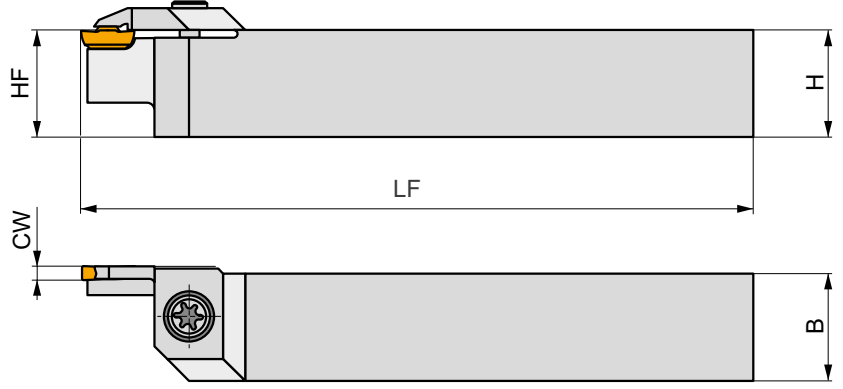
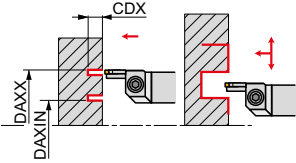

Product	HF	H	B	LF	CW	CDX	DAXIN	DAXX	kg	G1170	G1170
	(mm)	(mm)	(mm)	(mm)	(mm)	(mm)	(mm)	(mm)			
GFML 2525 M 0413L 030017	25	25	25	150	4.00	20	17	30	0.62	G1170	GL02
GFML 2525 M 0413L 034021	25	25	25	150	4.00	20	21	34	0.63	G1170	GL07
GFML 2525 M 0413L 040026	25	25	25	150	4.00	20	26	40	0.65	G1170	GL07
GFML 2525 M 0413L 050032	25	25	25	150	4.00	20	32	50	0.64	G1170	GL07
GFML 2525 M 0413L 060042	25	25	25	150	4.00	20	42	60	0.65	G1170	GL07
GFML 2525 M 0413L 075052	25	25	25	150	4.00	20	52	75	0.66	G1170	GL07
GFML 2525 M 0416L 100070	25	25	25	150	4.00	20	70	100	0.66	G1137	GL07
GFML 2525 M 0416L 130090	25	25	25	150	4.00	20	90	130	0.67	G1137	GL07
GFML 2525 M 0416L 170110	25	25	25	150	4.00	20	110	170	0.67	G1137	GL07
GFML 2525 M 0416L 230140	25	25	25	150	4.00	20	140	230	0.67	G1137	GL07



G1137
G1170



LCM. 0416..
LCM. 0413..



GL02
GL07



US 5015-T20P
US 5018-T20P



5.0
5.0



M 5
M 5



15
18.2



FLAG T20P
FLAG T20P



GFML-R AXIAL

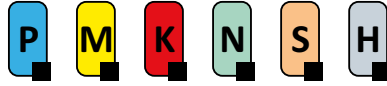

PRAMET

G



LCM. 04 Uç için V-Kanal Sıkmalı Dış Aksiyel Kanal Kateri

Tek veya çift taraflı LCM. 0413 ya da 0416 uçlar için sol kesme yönlü aksiyel kanal açma dış kateri. Derin aksiyel kanal açma, aksiyel profil işleme veya kanal genişletme. Ø17-230mm ve 20mm maksimum kesme derinliği. 25x25mm şaft ölçüleri. Gövde uzun takım ömrü için işlem görmüştür.

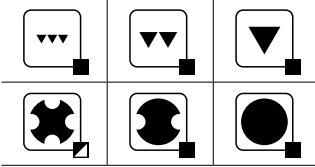
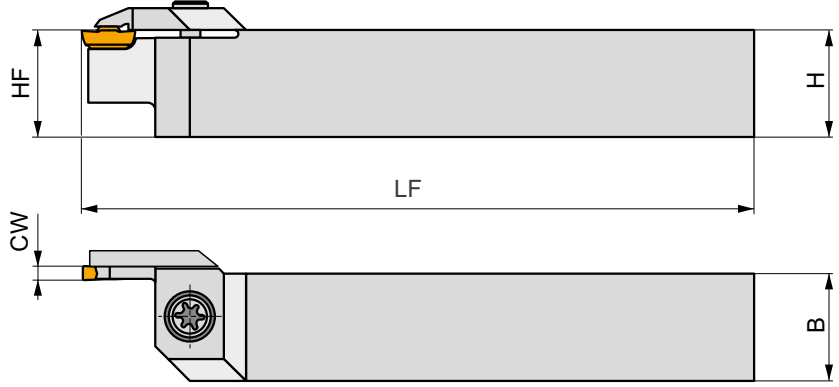
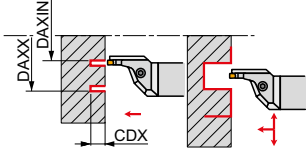

Product	HF	H	B	LF	CW	CDX	DAXIN	DAXX	kg	G1170	G1137
	(mm)	(mm)	(mm)	(mm)	(mm)	(mm)	(mm)	(mm)			
GFML 2525 M 0413R 030017	25	25	25	150	4.00	20	17	30	0.68	G1170	GL07
GFML 2525 M 0413R 034021	25	25	25	150	4.00	20	21	34	0.69	G1170	GL07
GFML 2525 M 0413R 040026	25	25	25	150	4.00	20	26	40	0.69	G1170	GL07
GFML 2525 M 0413R 050032	25	25	25	150	4.00	20	32	50	0.68	G1170	GL07
GFML 2525 M 0413R 060042	25	25	25	150	4.00	20	42	60	0.69	G1170	GL07
GFML 2525 M 0413R 075052	25	25	25	150	4.00	20	52	75	0.69	G1170	GL07
GFML 2525 M 0416R 100070	25	25	25	150	4.00	20	70	100	0.80	G1137	GL08
GFML 2525 M 0416R 130090	25	25	25	150	4.00	20	90	130	0.78	G1137	GL08
GFML 2525 M 0416R 170110	25	25	25	150	4.00	20	110	170	0.78	G1137	GL08
GFML 2525 M 0416R 230140	25	25	25	150	4.00	20	140	230	0.78	G1137	GL08



G1137
G1170

LCM. 0416..
LCM. 0413..



GL07
GL08

US 5018-T20P
US 6020-T25P

5.0
6.0

M 5
M 6

18.2
20.2

FLAG T20P
-

-
SDRT25P



GFMR-L AXIAL

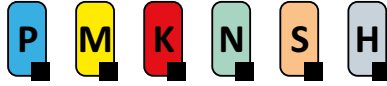

PRAMET

G



LCM. 04 Uç için V-Kanal Sıkmalı Dış Kanal Kateri

LCM. 0413 ve 0416 uçlar için sağ aksiyel dış kanal kateri. Ø17-230mm çap aralığında 20mm aralığında aksiyel kanal açma, aksiyel profil işleme ve kanal genişletme için uygundur. 25x25 şaft ölçülerinde bulunur. Gövde uzun takım ömrü için işlem görmüştür.

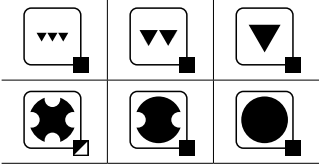
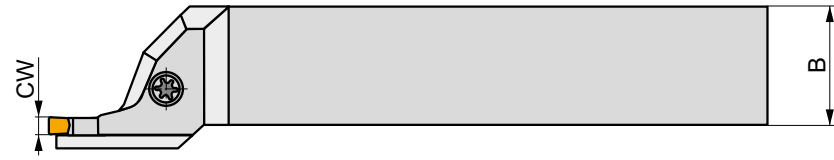
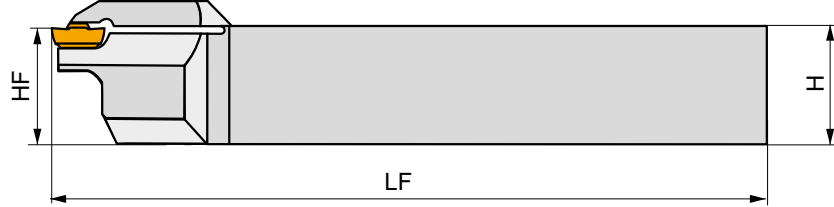
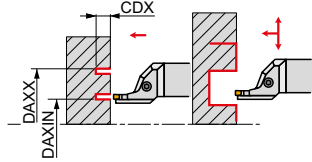

Product	EF	H	B	LF	CW	CDX	DAXIN	DAXX	kg	G1	G2
	(mm)	(mm)	(mm)	(mm)	(mm)	(mm)	(mm)	(mm)			
GFMR 2525 M 0413L 030017	25	25	25	150	4.00	20	17	30	0.70	G1170	GL07
GFMR 2525 M 0413L 034021	25	25	25	150	4.00	20	21	34	0.66	G1170	GL07
GFMR 2525 M 0413L 040026	25	25	25	150	4.00	20	26	40	0.66	G1170	GL07
GFMR 2525 M 0413L 050032	25	25	25	150	4.00	20	32	50	0.68	G1170	GL07
GFMR 2525 M 0413L 060042	25	25	25	150	4.00	20	42	60	0.66	G1170	GL07
GFMR 2525 M 0413L 075052	25	25	25	150	4.00	20	52	75	0.69	G1170	GL07
GFMR 2525 M 0416L 100070	25	25	25	150	4.00	20	70	100	0.88	G1137	GL08
GFMR 2525 M 0416L 130090	25	25	25	150	4.00	20	90	130	0.78	G1137	GL08
GFMR 2525 M 0416L 170110	25	25	25	150	4.00	20	110	170	0.81	G1137	GL08
GFMR 2525 M 0416L 230140	25	25	25	150	4.00	20	140	230	0.78	G1137	GL08



G1137

LCM. 0416..

G1170

LCM. 0413..



GL07

US 5018-T20P

5.0

M 5

18.2

FLAG T20P

-

GL08

US 6020-T25P

6.0

M 6

20.2

-

SDR T25P



GFMR-R AXIAL



PRAMET

G



LCM. 04 Uç için V-Kanal Sıkmalı Dış Kanal Kateri

LCM. 0413 ve 0416 uçlar için sağ aksiyel dış kanal kateri. Ø17-230mm çap aralığında 20mm aralığında aksiyel kanal açma, aksiyel profil işleme ve kanal genişletme için uygundur. 25x25 şaft ölçülerinde bulunur. Gövde uzun takım ömrü için işlem görmüştür.

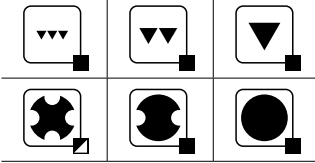
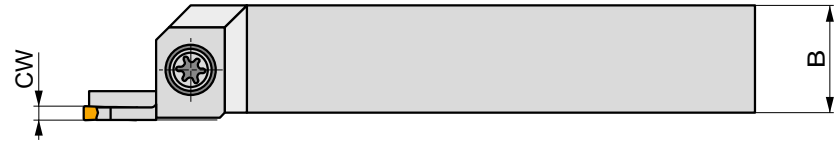
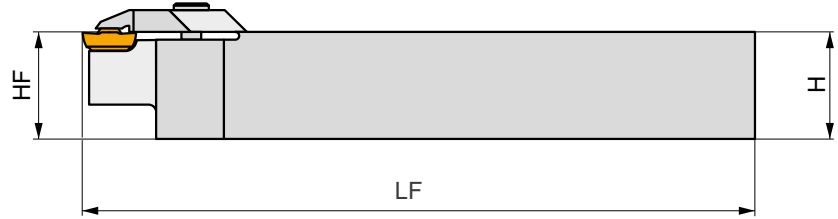
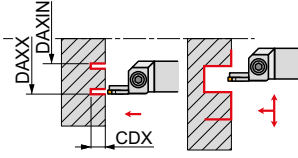

Product	⌀	H	B	LF	CW	CDX	DAXIN	DAXX	kg		
	(mm)	(mm)	(mm)	(mm)	(mm)	(mm)	(mm)	(mm)			
GFMR 2525 M 0413R 030017	25	25	25	150	4.00	20	17	30	0.62	GI170	GL02
GFMR 2525 M 0413R 034021	25	25	25	150	4.00	20	21	34	0.63	GI170	GL07
GFMR 2525 M 0413R 040026	25	25	25	150	4.00	20	26	40	0.64	GI170	GL07
GFMR 2525 M 0413R 050032	25	25	25	150	4.00	20	32	50	0.63	GI170	GL07
GFMR 2525 M 0413R 060042	25	25	25	150	4.00	20	42	60	0.64	GI170	GL07
GFMR 2525 M 0413R 075052	25	25	25	150	4.00	20	52	75	0.67	GI170	GL07
GFMR 2525 M 0416R 100070	25	25	25	150	4.00	20	70	100	0.67	GI137	GL07
GFMR 2525 M 0416R 130090	25	25	25	150	4.00	20	90	130	0.66	GI137	GL07
GFMR 2525 M 0416R 170110	25	25	25	150	4.00	20	110	170	0.67	GI137	GL07
GFMR 2525 M 0416R 230140	25	25	25	150	4.00	20	140	230	0.68	GI137	GL07



GI137
GI170

LCM. 0416..
LCM. 0413..



GL02
GL07

US 5015-T20P
US 5018-T20P

5.0
5.0

M 5
M 5

15
18.2

FLAG T20P
FLAG T20P



GGI(RL)-90 AXIAL



PRAMET

G



LCM. 03 Uç için V-Kanal Sıkmalı Dış Aksiyel 90° Kanal Kateri

Tek veya çift taraflı LCM. 0313 ya da 0316 uçlar için Sağ/Sol kesme yönlü aksiyel 90° kanal açma dış kateri. Derin aksiyel kanal açma, aksiyel profil işleme veya kanal genişletme. Ø17-170mm ve 11mm maksimum kesme derinliği. 25x25mm şaft ölçüleri. Gövde uzun takım ömrü için işlem görmüştür.

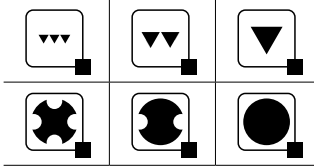
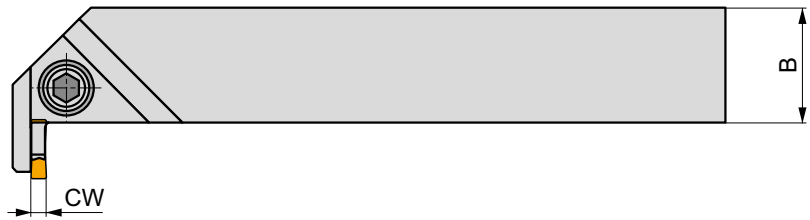
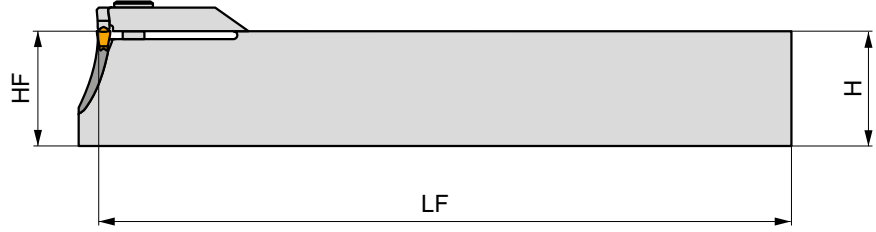
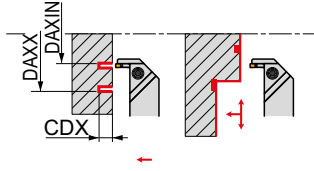

Product	HF	H	B	LF	CW	CDX	DAXIN	DAXX	kg	GI136	GI143
	(mm)	(mm)	(mm)	(mm)	(mm)	(mm)	(mm)	(mm)			
R GGIR 2525 M 03R 030017	25	25	25	150	3.00	9.5	17	30	0.75	GI143	GL01
GGIR 2525 M 03R 039024	25	25	25	150	3.00	9.5	24	39	0.78	GI143	GL01
GGIR 2525 M 03R 050033	25	25	25	150	3.00	11	33	50	0.75	GI143	GL01
GGIR 2525 M 03R 060043	25	25	25	150	3.00	11	43	60	0.78	GI143	GL01
GGIR 2525 M 03R 076053	25	25	25	150	3.00	11	53	76	0.75	GI143	GL01
GGIR 2525 M 03R 100070	25	25	25	150	3.00	9	70	100	0.78	GI136	GL04
GGIR 2525 M 03R 130090	25	25	25	150	3.00	9	90	130	0.73	GI136	GL04
GGIR 2525 M 03R 170110	25	25	25	150	3.00	9	110	170	0.76	GI136	GL04
L GGIL 2525 M 03L 030017	25	25	25	150	3.00	9.5	17	30	0.75	GI143	GL01
GGIL 2525 M 03L 039024	25	25	25	150	3.00	9.5	24	39	0.25	GI143	GL01
GGIL 2525 M 03L 050033	25	25	25	150	3.00	11	33	50	0.75	GI143	GL01
GGIL 2525 M 03L 060043	25	25	25	150	3.00	11	43	60	0.75	GI143	GL01
GGIL 2525 M 03L 076053	25	25	25	150	3.00	11	53	76	0.75	GI143	GL01
GGIL 2525 M 03L 100070	25	25	25	150	3.00	9	70	100	0.77	GI136	GL04
GGIL 2525 M 03L 130090	25	25	25	150	3.00	9	90	130	0.77	GI136	GL04
GGIL 2525 M 03L 170110	25	25	25	150	3.00	9	110	170	0.76	GI136	GL04



GI136

LCM. 0316..

GI143

LCM. 0313..



GL01

HS 0520C

5.0

M 5

20

HXK 4

GL04

HS 0620C

6.0

M 6

20

HXK 5

LCMF 20 - F1

	CW	CWTOLL	CWTOLU	INSL
	(mm)	(mm)	(mm)	(mm)
0220	2.00	-0.03	0.03	19.5

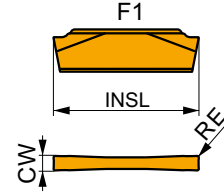

Kesme hızı (vc), ilerleme (f) için uygunluk ve başlangıç değerleri. Daha ileri hesaplamalar için İşleme Hesaplayıcısı uygulamasına başvurun.

Product	RE	P		M		K		N		S		H		PSIRR	PSIRL
		vc	f	vc	f	vc	f	vc	f	vc	f	vc	f		

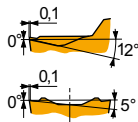

F1 geometri, kesme ve kanal açma için, ince ve finiş işleme, ve darbesizden hafif darbeli işlemeye kadar uygun.

LCMF 022002-F1	T8330	0.2	205	0.09	120	0.08	190	0.09	-	-	-	-	-	-	-
----------------	-------	-----	-----	------	-----	------	-----	------	---	---	---	---	---	---	---

LCMF 20 - M2

	CW	CWTOLL	CWTOLU	INSL
	(mm)	(mm)	(mm)	(mm)
0220	2.00	-0.03	0.03	19.5

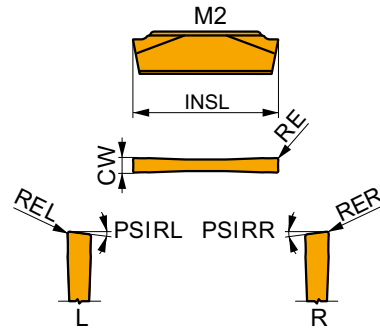

Kesme hızı (vc), ilerleme (f) için uygunluk ve başlangıç değerleri. Daha ileri hesaplamalar için İşleme Hesaplayıcısı uygulamasına başvurun.

Product	RE	P		M		K		N		S		H		PSIRR	PSIRL
		vc	f	vc	f	vc	f	vc	f	vc	f	vc	f		

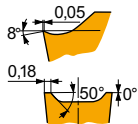

M2 geometri, kesme ve kanal açma için, ince ve finiş işleme, ve darbesizden hafif darbeli kesime kadar uygun.

LCMF 022002-M2	T8330	0.2	180	0.12	105	0.11	170	0.12	-	-	-	-	-	-	-
----------------	-------	-----	-----	------	-----	------	-----	------	---	---	---	---	---	---	---

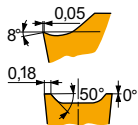

R-M2 sağ kesme yönlü geometri, kesme için ve darbesizden hafif darbeli kesime kadar uygun.

LCMF 022002R6-M2	T8330	0.2	130	0.12	75	0.11	120	0.12	-	-	-	-	6	-
------------------	-------	-----	-----	------	----	------	-----	------	---	---	---	---	---	---

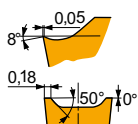

L-M2 sol kesme yönlü geometri, kesme için ve darbesizden hafif darbeli kesime kadar uygun.

LCMF 022002L6-M2	T8330	0.2	130	0.12	75	0.11	120	0.12	-	-	-	-	-	6
------------------	-------	-----	-----	------	----	------	-----	------	---	---	---	---	---	---

LCMF 20 - MP

	CW	CWTOLL	CWTOLU	INSL
	(mm)	(mm)	(mm)	(mm)
0220	2.00	-0.03	0.03	19.5

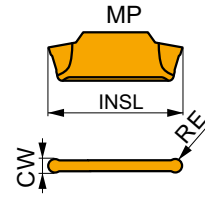

Kesme hızı (vc), ilerleme (f) ve kesme derinliği (ap) için uygunluk ve başlangıç değerleri. Daha ileri hesaplamalar için İşleme Hesaplayıcısı uygulamasına başvurun.

Product	RE (mm)	P			M			K			N			S			H		
		vc (m/min)	f (mm/rev)	ap (mm)	vc (m/min)	f (mm/rev)	ap (mm)	vc (m/min)	f (mm/rev)	ap (mm)	vc (m/min)	f (mm/rev)	ap (mm)	vc (m/min)	f (mm/rev)	ap (mm)	vc (m/min)	f (mm/rev)	ap (mm)

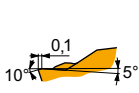

MP geometri, kopya profil ve çap tormalama, ince ve finiş işleme için, ve darbesizden darbeli kesime kadar uygun.

LCMF 0220MO-MP	T8330	1.0	200	0.30	0.5	120	0.27	0.5	190	0.30	0.5	-	-	-	-	-	-	-
----------------	-------	-----	-----	------	-----	-----	------	-----	-----	------	-----	---	---	---	---	---	---	---

GFK(RL) EXT

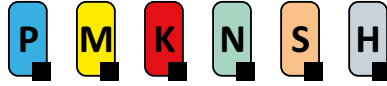

PRAMET

G



LCMF 0220 Uç için V-Kanal Sıkmalı Dış Kesme ve Kanal Kateri

LCMF 0220 uçlar için Sağ/Sol dış kanal kateri. 16mm derinliğe kadar kesme, kanal açma ve profil işleme için uygundur. 16x16-25x25 şaft ölçülerinde bulunur. Gövde uzun takım ömrü için işlem görmüştür.

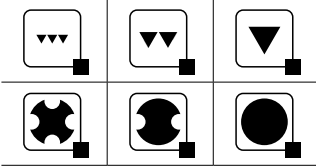
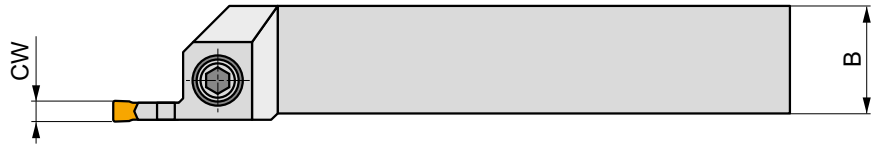
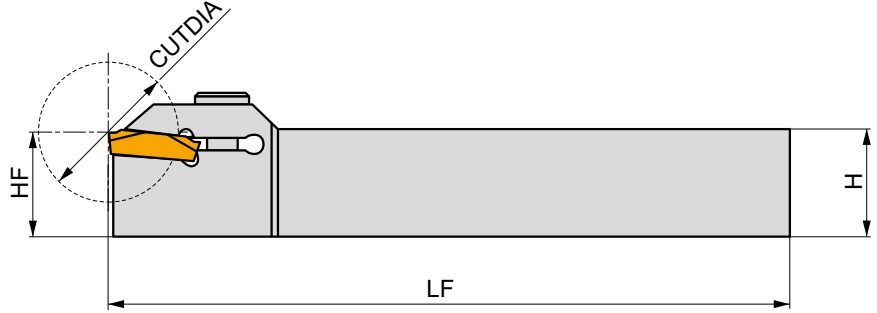
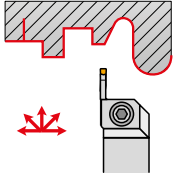

Product	≡	H	B	LF	CW	CUTDIA	kg		
	(mm)	(mm)	(mm)	(mm)	(mm)	(mm)			
R	GFKR 1616 H 02	16	16	16	100	2.00	0.20	G1168	GL03
	GFKR 2020 K 02	20	20	20	125	2.00	0.38	G1168	GL04
	GFKR 2525 M 02	25	25	25	150	2.00	0.68	G1168	GL05
L	GFKL 1616 H 02	16	16	16	100	2.00	0.20	G1168	GL03
	GFKL 2020 K 02	20	20	20	125	2.00	0.38	G1168	GL04
	GFKL 2525 M 02	25	25	25	150	2.00	0.68	G1168	GL05



G1168



LCMF 0220..



GL03



HS 0616C



6.0



M 6



16



HXK 5

GL04

HS 0620C

6.0

M 6

20

HXK 5

GL05

HS 0625C

6.0

M 6

25

HXK 5

LFMX - F1

PRAMET

	CW	CWTOLL	CWTOLU	BW
	(mm)	(mm)	(mm)	(mm)
1.5	1.50	-0.03	0.03	1.30
1.6	1.60	-0.03	0.03	1.30
2.0	2.00	-0.03	0.03	1.60
3.1	3.10	-0.04	0.04	2.60
4.1	4.10	-0.04	0.04	3.60

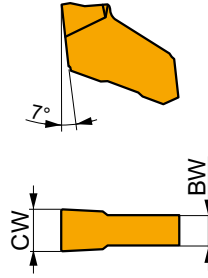

Kesme hızı (vc), ilerleme (f) için uygunluk ve başlangıç değerleri. Daha ileri hesaplamalar için İşleme Hesaplayıcısı uygulamasına başvurun.

Product	RE	P		M		K		N		S		H		PSIRR	PSIRL
		vc	f	vc	f	vc	f	vc	f	vc	f	vc	f		
	(mm)	(m/min)	(mm/rev)	(m/min)	(mm/rev)	(m/min)	(mm/rev)	(m/min)	(mm/rev)	(m/min)	(mm/rev)	(m/min)	(mm/rev)	(°)	(°)



EN-F1 geometri, kesme ve kanal açma için, darbesiz işlemeye uygun.

LFMX 1.5-.16ENF1	T8330	0.2	130	0.08	75	0.07	120	0.08	-	-	-	-	-	-	-
LFMX 1.6-.16ENF1	T8330	0.2	130	0.08	75	0.07	120	0.08	-	-	-	-	-	-	-
LFMX 2.0-.16ENF1	T8330	0.2	130	0.08	75	0.07	120	0.08	-	-	-	-	-	-	-
LFMX 3.1-.20ENF1	T8330	0.2	130	0.10	75	0.09	120	0.10	-	-	-	-	-	-	-
LFMX 4.1-.20ENF1	T8330	0.2	130	0.10	75	0.09	120	0.10	-	-	-	-	-	-	-

LFMX - F2

PRAMET

	CW	CWTOLL	CWTOLU	BW
	(mm)	(mm)	(mm)	(mm)
1.6	1.60	-0.03	0.03	1.30
2.0	2.00	-0.03	0.03	1.60
3.1	3.10	-0.04	0.04	2.60
4.1	4.10	-0.04	0.04	3.60
5.1	5.10	-0.04	0.04	4.60
6.35	6.35	-0.04	0.04	5.80

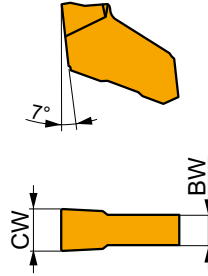

Kesme hızı (vc), ilerleme (f) için uygunluk ve başlangıç değerleri. Daha ileri hesaplamalar için İşleme Hesaplayıcısı uygulamasına başvurun.

Product	RE	P		M		K		N		S		H		PSIRR	PSIRL
		vc	f	vc	f	vc	f	vc	f	vc	f	vc	f		
	(mm)	(m/min)	(mm/rev)	(m/min)	(mm/rev)	(m/min)	(mm/rev)	(m/min)	(mm/rev)	(m/min)	(mm/rev)	(m/min)	(mm/rev)	(°)	(°)

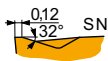

SN-F2 geometri, kesme ve kanal açma, darbesiz kesim için.

LFMX 1.6-.16SNF2	T8330	0.2	130	0.10	75	0.09	120	0.10	-	-	-	-	-	-	-
LFMX 2.0-.16SNF2	6640	0.2	150	0.10	90	0.09	140	0.10	-	-	-	-	-	-	-
	T8330	0.2	130	0.10	75	0.09	120	0.10	-	-	-	-	-	-	-
LFMX 3.1-.20SNF2	6640	0.2	150	0.10	90	0.09	140	0.10	-	-	-	-	-	-	-
	T8330	0.2	130	0.10	75	0.09	120	0.10	-	-	-	-	-	-	-
LFMX 4.1-.20SNF2	T8330	0.2	130	0.12	75	0.11	120	0.12	-	-	-	-	-	-	-
LFMX 5.1-.20SNF2	T8330	0.2	130	0.12	75	0.11	120	0.12	-	-	-	-	-	-	-
LFMX 6.35-.20SNF2	T8330	0.2	130	0.15	75	0.14	120	0.15	-	-	-	-	-	-	-

Kesme hızı (vc), ilerleme (f) için uygunluk ve başlangıç değerleri. Daha ileri hesaplamalar için İşleme Hesaplayıcısı uygulamasına başvurun.

Product	RE (mm)	P		M		K		N		S		H		PSIRR (°)	PSIRL (°)
		vc (m/min)	f (mm/rev)	vc (m/min)	f (mm/rev)	vc (m/min)	f (mm/rev)	vc (m/min)	f (mm/rev)	vc (m/min)	f (mm/rev)	vc (m/min)	f (mm/rev)		

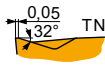

TN-F2 geometri, kesme ve kanal açma için, darbesiz kesim.

LFMX 3.1-.20TNF2	6640	0.2	150	0.10	90	0.09	140	0.10	-	-	-	-	-	-	-
	T8330	0.2	130	0.10	75	0.09	120	0.10	-	-	-	-	-	-	-
LFMX 4.1-.20TNF2	T8330	0.2	130	0.12	75	0.11	120	0.12	-	-	-	-	-	-	-

LFMX - M2

PRAMET

	CW (mm)	CWTOLL (mm)	CWTOLU (mm)	BW (mm)
2.0	2.00	-0.03	0.03	1.60
2.2	2.20	-0.03	0.03	1.60
3.1	3.10	-0.04	0.04	2.60
4.1	4.10	-0.04	0.04	3.60
5.1	5.10	-0.04	0.04	4.60
6.35	6.35	-0.04	0.04	5.80

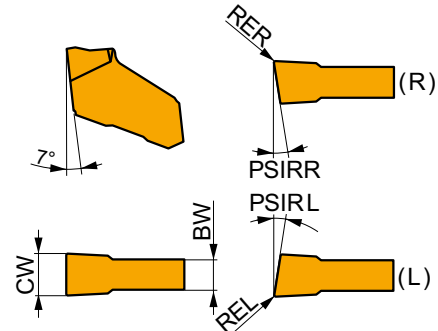

Kesme hızı (vc), ilerleme (f) için uygunluk ve başlangıç değerleri. Daha ileri hesaplamalar için İşleme Hesaplayıcısı uygulamasına başvurun.

Product	RE (mm)	P		M		K		N		S		H		PSIRR (°)	PSIRL (°)
		vc (m/min)	f (mm/rev)	vc (m/min)	f (mm/rev)	vc (m/min)	f (mm/rev)	vc (m/min)	f (mm/rev)	vc (m/min)	f (mm/rev)	vc (m/min)	f (mm/rev)		

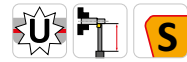
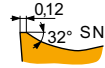

SN-F2 geometri, kesme ve kanal açma, darbesiz ve hafif darbeleri kesim için.

LFMX 2.0-.16SNM2	6640	0.2	150	0.11	90	0.10	140	0.11	-	-	-	-	-	-	-
	T8330	0.2	130	0.11	75	0.10	120	0.11	-	-	-	-	-	-	-
LFMX 2.2-.16SNM2	6640	0.2	150	0.11	90	0.10	140	0.11	-	-	-	-	-	-	-
	T8330	0.2	130	0.11	75	0.10	120	0.11	-	-	-	-	-	-	-
LFMX 3.1-.20SNM2	6640	0.2	150	0.15	90	0.14	140	0.15	-	-	-	-	-	-	-
	T8330	0.2	130	0.15	75	0.14	120	0.15	-	-	-	-	-	-	-
LFMX 4.1-.20SNM2	6640	0.2	150	0.15	90	0.14	140	0.15	-	-	-	-	-	-	-
	T8330	0.2	130	0.15	75	0.14	120	0.15	-	-	-	-	-	-	-
LFMX 5.1-.20SNM2	6640	0.2	150	0.20	90	0.18	140	0.20	-	-	-	-	-	-	-
	T8330	0.2	130	0.20	75	0.18	120	0.20	-	-	-	-	-	-	-
LFMX 6.35-.20SNM2	6640	0.2	150	0.20	90	0.18	140	0.20	-	-	-	-	-	-	-
	T8330	0.2	130	0.20	75	0.18	120	0.20	-	-	-	-	-	-	-

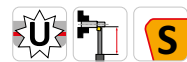
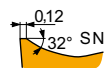
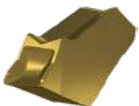

SR-M2 sağ kesme yönlü geometri, kesme, darbesiz ve hafif darbeleri kesim için.

LFMX 2.0-.16SR12M2	T8330	0.2	130	0.09	75	0.08	120	0.09	-	-	-	-	12	-
LFMX 2.0-.16SR6M2	T8330	0.2	130	0.09	75	0.08	120	0.09	-	-	-	-	6	-
LFMX 3.1-.20SR8M2	T8330	0.2	130	0.11	75	0.10	120	0.11	-	-	-	-	8	-
LFMX 4.1-.20SR8M2	T8330	0.2	130	0.15	75	0.14	120	0.15	-	-	-	-	8	-

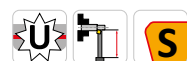
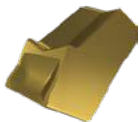

SL-M2 sol kesme yönlü geometri, kesme için, ve darbesizden hafif darbeleri kesime kadar uygun.

LFMX 2.0-.16SL12M2	T8330	0.2	130	0.09	75	0.08	120	0.09	-	-	-	-	-	12
LFMX 2.0-.16SL6M2	T8330	0.2	130	0.09	75	0.08	120	0.09	-	-	-	-	-	6

Kesme hızı (vc), ilerleme (f) için uygunluk ve başlangıç değerleri. Daha ileri hesaplamalar için İşleme Hesaplayıcısı uygulamasına başvurun.

Product	RE (mm)	P		M		K		N		S		H		PSIRR (°)	PSIRL (°)
		vc (m/min)	f (mm/rev)	vc (m/min)	f (mm/rev)	vc (m/min)	f (mm/rev)	vc (m/min)	f (mm/rev)	vc (m/min)	f (mm/rev)	vc (m/min)	f (mm/rev)		

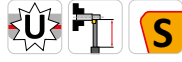
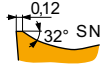
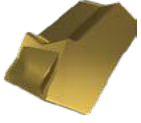

SL-M2 sol kesme yönlü geometri, kesme için, ve darbesizden hafif darbeli kesime kadar uygun.

LFMX 3.1-.20SL8M2	T8330	0.2	130	0.11	75	0.10	120	0.11	-	-	-	-	-	-	8
LFMX 4.1-.20SL8M2	T8330	0.2	130	0.15	75	0.14	120	0.15	-	-	-	-	-	-	8

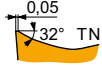

TN-M2 geometri, kesme ve kanal açma için, darbesiz ve hafif darbeli kesim.

LFMX 3.1-.20TNM2	6640	0.2	150	0.15	90	0.14	140	0.15	-	-	-	-	-	-	-
	T8330	0.2	130	0.15	75	0.14	120	0.15	-	-	-	-	-	-	-
LFMX 4.1-.20TNM2	6640	0.2	150	0.15	90	0.14	140	0.15	-	-	-	-	-	-	-
	T8330	0.2	130	0.15	75	0.14	120	0.15	-	-	-	-	-	-	-

XLCFN B



PRAMET

X



LFMX Uçlar için Çift Taraflı Kesme Laması

80mm derinlik ya da Ø160mm çapa kadar kesme işlemleri için lama. Tek taraflı LFMX uçlar için. 26, 32 veya 45mm yüksekliklerinde. DU Pramet baz tutuculara uygundur. Lama uzun takım ömrü için işlem görmüştür.

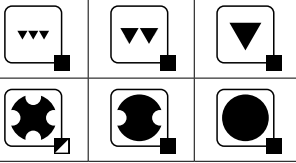
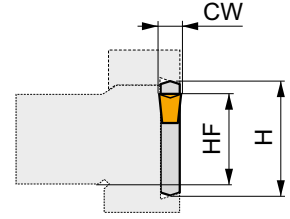
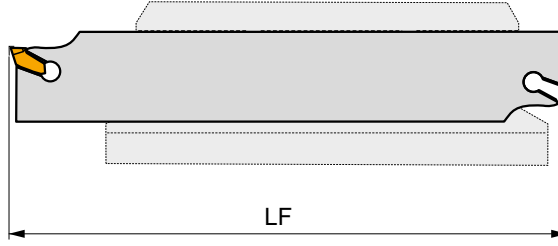
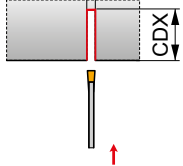

Product	⌀	H	LF	CW	CDX	kg	GI	KV	
	(mm)	(mm)	(mm)	(mm)	(mm)				
N	XLCFN 2601 J 1.60	21.4	26	110	1.50	15	0.03	GI132	KV
	XLCFN 2601 J 2.00	21.4	26	110	2.00	25	0.04	GI061	KV
	XLCFN 2602 J 3.00	21.4	26	110	3.10	37.5	0.05	GI001	KV
	XLCFN 2603 J 4.00	21.4	26	110	4.10	40	0.06	GI002	KV
	XLCFN 3201 M 1.60	25	32	150	1.50	15	0.06	GI132	KV
	XLCFN 3201 M 2.00	25	32	150	2.00	25	0.11	GI061	KV
	XLCFN 3202 M 3.00	25	32	150	3.10	50	0.08	GI001	KV
	XLCFN 3203 M 4.00	25	32	150	4.10	50	0.11	GI002	KV
	XLCFN 3204 M 5.00	25	32	150	5.10	60	0.14	GI004	KV
	XLCFN 3205 M 6.35	25	32	150	6.35	60	0.17	GI005	KV
	XLCFN 4502 S 3.00	32	45	250	3.10	80	0.12	GI001	KV
	XLCFN 4503 S 4.00	32	45	250	4.10	80	0.19	GI002	KV
	XLCFN 4504 S 5.00	32	45	250	5.10	80	0.28	GI004	KV
	XLCFN 4505 S 6.35	32	45	250	6.35	80	0.40	GI005	KV

GI	LFMX	LFMX
GI001	LFMX 3.1.-.	-
GI002	LFMX 4.1.-.	-
GI004	LFMX 5.1.-.	-
GI005	LFMX 6.35.-.	-
GI061	LFMX 2.0.-.	LFMX 2.2.-.
GI132	LFMX 1.5.-.	LFMX 1.6.-.

KV	LFMX
KV	LFMX 5x70

DU, D**PRAMET****Kesme Lamaları için Takım Tutucu**

GL veya XLC. lamalar için tutucu. 20x20-40x40mm shaft ölçülerinde bulunur. Gövde uzun takım ömrü için işlem görmüştür.

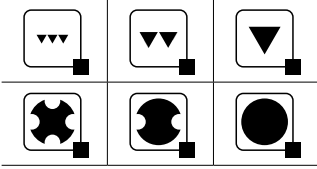
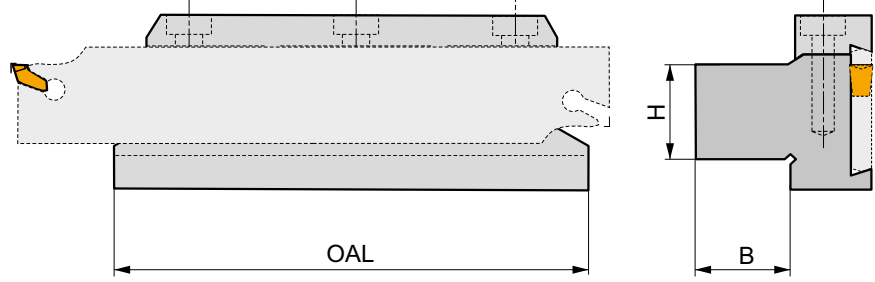
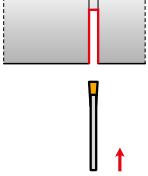

Product	H (mm)	B (mm)	OAL (mm)	kg		
26-DU 2020	20	20	90	0.70	GI007	ND2
26-D 2020	20	20	100	0.82	GI007	ND2
32-DU 2523	25	23	110	1.02	GI008	ND2
32-DU 2532	25	32	110	1.10	GI008	ND2
32-DU 3229	32	29	110	1.25	GI008	ND2
32-D 2530	25	30	115	1.30	GI008	ND2
45-DU 3229	32	29	110	1.50	GI009	ND7
45-DU 4036	40	36	110	2.05	GI009	ND7
47-D 4040	40	40	150	3.88	GI091	ND3

GI007	XLC.N 26..	GL.-S26.B
GI008	XLC.N 32..	GL.-S32.B
GI009	XLC.N 45..	-
GI091	XLC.N 47..	-

ND2	HS 0625	6.0	M 6	25	HXX 5
ND3	HS 1030	8.0	M 10	30	HXX 8
ND7	HS 0630	6.0	M 6	30	HXX 5

XLCF(NRL) BS

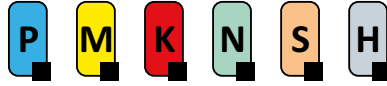

PRAMET



Modüler LFMX Uçlu MS-EN Takım için Radyal Kanal Açma Laması

Tek taraflı LFMX uçlar için modüler kanal açma laması. Aksiyel kanal açma ve kesme (maks. 25mm kesme derinliği) uygulamaları için uygundur. Lamalar uzun takım ömrü için işlem görmüştür.

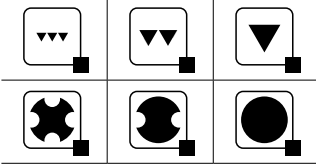
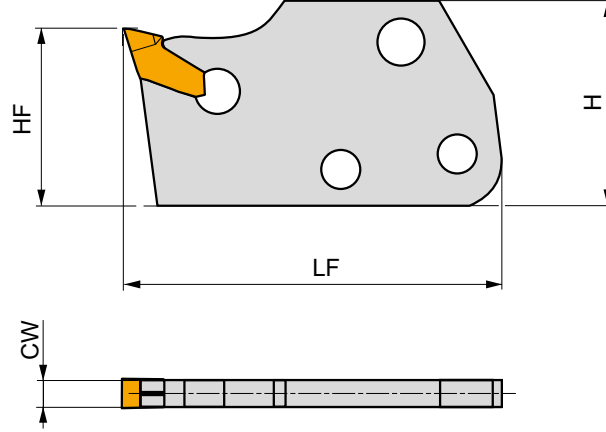
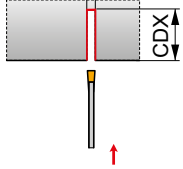

Product	H	H	LF	CW	CDX	kg			
	(mm)	(mm)	(mm)	(mm)	(mm)				
R	XLCFR 160115-1.60	12	25	35	1.50	15	0.01	GI132	KV
	XLCFR 160115-2.00	12	25	35	2.00	15	0.01	GI061	KV
	XLCFR 250115-1.60	24	29	40	1.50	15	0.01	GI132	KV
	XLCFR 250115-2.00	24	29	40	2.00	15	0.05	GI061	KV
L	XLCFL 160115-1.60	12	25	35	1.50	15	0.01	GI132	KV
	XLCFL 160115-2.00	12	25	35	2.00	15	0.04	GI061	KV
	XLCFL 250115-1.60	24	29	40	1.50	15	0.01	GI132	KV
	XLCFL 250115-2.00	24	29	40	2.00	15	0.05	GI061	KV
N	XLCFN 160215-3.00	12	25	35	3.10	15	0.01	GI001	KV
	XLCFN 160220-3.00	12	25	40	3.10	20	0.02	GI001	KV
	XLCFN 250215-3.00	24	29	40	3.10	15	0.02	GI001	KV
	XLCFN 250225-3.00	24	29	50	3.10	25	0.02	GI001	KV
	XLCFN 250315-4.00	24	29	40	4.10	15	0.02	GI002	KV
	XLCFN 250325-4.00	24	29	50	4.10	25	0.03	GI002	KV
	XLCFN 250425-5.00	24	29	50	5.10	25	0.04	GI004	KV
	XLCFN 250525-6.35	24	29	50	6.35	25	0.04	GI005	KV

GI001	LFMX 3.1-.	-	-
GI002	LFMX 4.1-.	-	-
GI004	LFMX 5.1-.	-	-
GI005	LFMX 6.35-.	-	-
GI061	LFMX 2.0-.	LFMX 2.2-.	-
GI132	LFMX 1.5-.	LFMX 1.6-.	-

KV		KV 5x70

XLXFL BS AXIAL



PRAMET

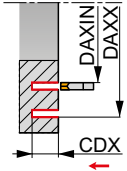

Modüler LFMX Uçlu MS-EN Takım için Aksiyel Kanal Açma Laması

Tek taraflı LFMX 3.1 uçlar için modüler kanal açma laması. Aksiyel kanal açma ve kesme (maks. 20mm kesme derinliği) uygulamaları için uygundur. MS-EN tutucu ile kullanılır. Lamalar uzun takım ömrü için işlem görmüştür.

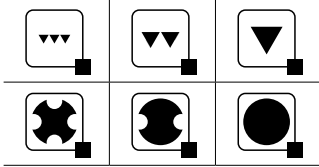
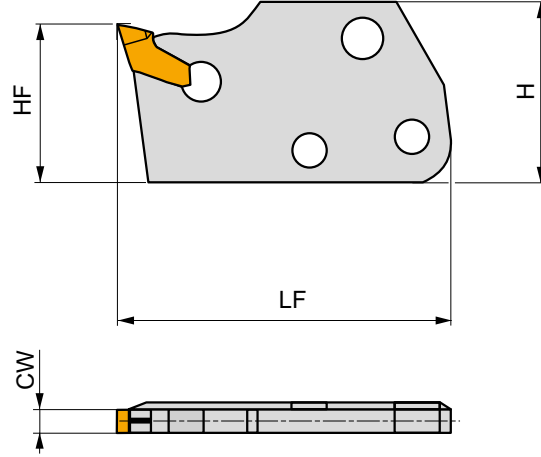

Product	H	HF	LF	CW	CDX	DAXIN	DAXX	kg		
	(mm)	(mm)	(mm)	(mm)	(mm)	(mm)	(mm)			
XLXFL 250220-3.00-60	29	24	46	3.10	20	60	85	0.07	G1001	KV
XLXFL 250220-3.00-80	29	24	46	3.10	20	80	105	0.05	G1001	KV
XLXFL 250220-3.00-100	29	24	46	3.10	20	100	155	0.03	G1001	KV
XLXFL 250220-3.00-150	29	24	46	3.10	20	150	280	0.03	G1001	KV



G1001



LFMX 3.1-.



KV



KV 5x70



XLCCN, XLCF(NRL) veya XLFL Kanal Laması için Modüler Takım Tutucu

XLCC 25 BS, XLCF(NRL) BS, XLFL BS modüler lamalar için tutucu. 12x12-32x25mm şaft ölçülerinde bulunur. Gövde uzun takım ömrü için işlem görmüştür.

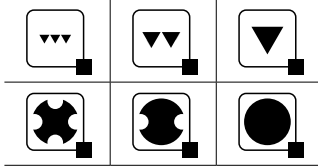
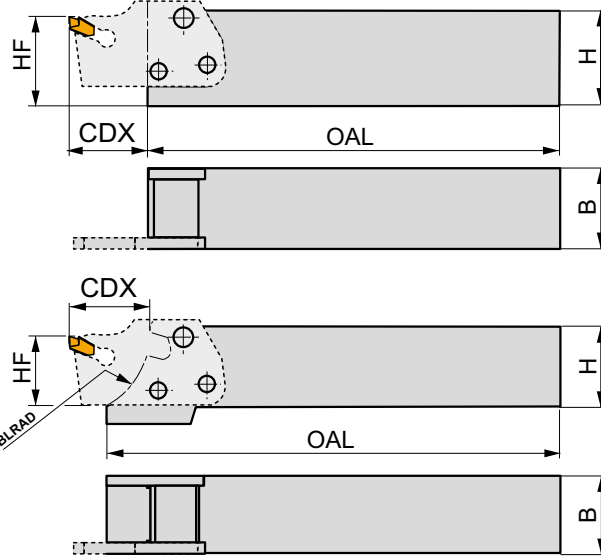
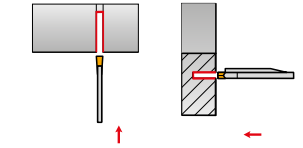

Product	HF (mm)	H (mm)	B (mm)	OAL (mm)	CDX (mm)	BLRAD (mm)	kg	GI	ND
MS-EN-1212 F	12	12	12	75	15	-	0.13	GI006	ND4
MS-EN-1616 H	16	16	16	90	15	-	0.21	GI006	ND4
MS-EN-2020 K	20	20	20	115	15	-	0.23	GI003	ND5
MS-EN-2020 KS	20	20	20	129	15	25	0.42	GI060	ND5
MS-EN-2525 M	25	25	25	140	15	-	0.65	GI003	ND5
MS-EN-2525 MS	25	25	25	153	15	25	0.74	GI060	ND5
MS-EN-3225 P	32	32	25	160	15	-	0.95	GI003	ND5
MS-EN-3225 PS	32	32	25	174	15	25	1.00	GI060	ND5

GI	XLCC	XLXFL	XLCF
GI003	XLCC.. 25..15...	XLXFL 25...	XLCF.. 25..25...
GI006	XLCF. 16..15...	XLCF. 16..20...	-
GI060	XLCC.. 25..15...	XLCC.. 25..25...	-

ND	US	Nm	M	mm	US	Nm	M	mm	FLAG
ND4	US 4011-T15P	3.5	M 4	10.6	-	-	-	-	FLAG T15P
ND5	US 45013-T20P	5.0	M 5	13	US 46017-T20P	5.0	M6	17	FLAG T15P

ND4 = 3 x US 4011-T15P; ND5 = 2 x US 45013-T20P

LFUX

	CW	BW	INSL
	(mm)	(mm)	(mm)
0308	3.00	2.51	11.5
0408	4.00	3.44	11.5
0508	5.00	4.30	11.5
0608	6.00	5.30	11.5

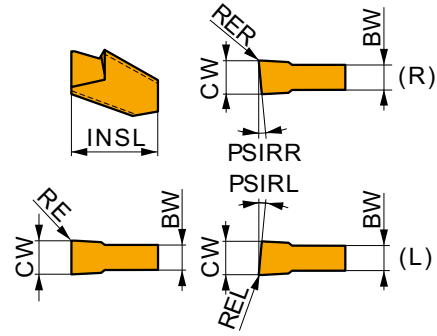

Kesme hızı (vc), ilerleme (f) için uygunluk ve başlangıç değerleri. Daha ileri hesaplamalar için İşleme Hesaplayıcısı uygulamasına başvurun.

Product	RE	P		M		K		N		S		H		PSIRR	PSIRL
		vc	f	vc	f	vc	f	vc	f	vc	f	vc	f		
	(mm)	(m/min)	(mm/rev)	(m/min)	(mm/rev)	(m/min)	(mm/rev)	(m/min)	(mm/rev)	(m/min)	(mm/rev)	(m/min)	(mm/rev)	(°)	(°)

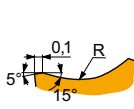

TN geometri, kesme ve kanal açma için, darbesiz ve hafif darbeleri kesim.

LFUX 030802TN	6640	0.2	150	0.10	-	-	140	0.10	-	-	-	-	-	-	-
	T8330	0.2	130	0.10	-	-	120	0.10	-	-	-	-	-	-	-
LFUX 040802TN	6640	0.2	150	0.12	-	-	140	0.12	-	-	-	-	-	-	-
	T8330	0.2	130	0.12	-	-	120	0.12	-	-	-	-	-	-	-
LFUX 050802TN	6640	0.2	150	0.15	-	-	140	0.15	-	-	-	-	-	-	-
	T8330	0.2	130	0.15	-	-	120	0.15	-	-	-	-	-	-	-
LFUX 060802TN	6640	0.2	150	0.20	-	-	140	0.20	-	-	-	-	-	-	-
	T8330	0.2	130	0.20	-	-	120	0.20	-	-	-	-	-	-	-

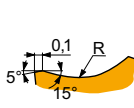

TR geometri, sağ kesme yönlü, kesme için, darbesiz ve hafif darbeleri kesim.

LFUX 030800TR	6640	0.2	150	0.10	-	-	140	0.10	-	-	-	-	5	-
	T8330	0.2	130	0.10	-	-	120	0.10	-	-	-	-	5	-
LFUX 040800TR	6640	0.2	150	0.12	-	-	140	0.12	-	-	-	-	5	-
	T8330	0.2	130	0.12	-	-	120	0.12	-	-	-	-	5	-

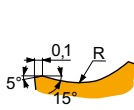

TL sol kesme yönlü geometri, kesme, darbesiz ve hafif darbeleri kesim için.

LFUX 030800TL	6640	0.2	150	0.10	-	-	140	0.10	-	-	-	-	-	5
	T8330	0.2	130	0.10	-	-	120	0.10	-	-	-	-	-	5

XLCF(RL)



PRAMET

X



LFUX Uç için Dış Kesme ve Kanal Kateri

Tek taraflı LFUX 0308, 0408, 0508 veya 0608 uçlar için Sağ/Sol radyal dış kanal kateri. Ø65mm çapa kadar kesme için uygundur. 16x12-32x25 şaft ölçülerinde bulunur. Gövde uzun takım ömrü için işlem görmüştür.

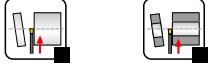
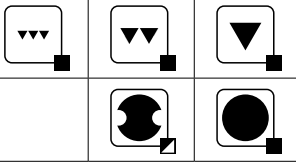
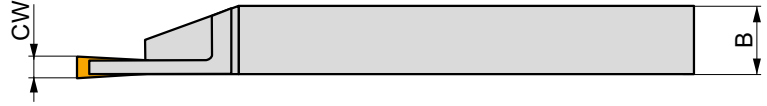
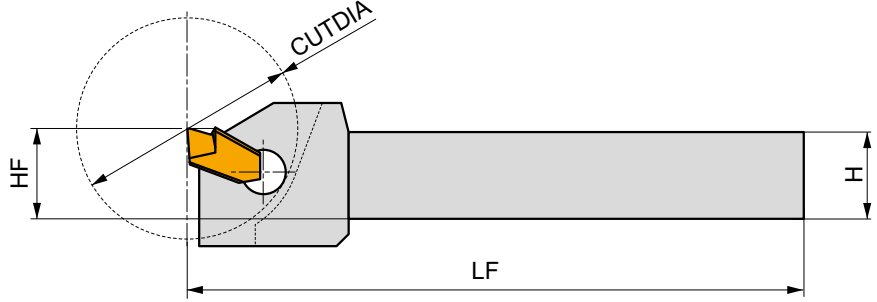
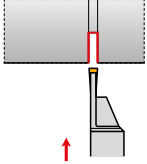

Product	HF (mm)	H (mm)	B (mm)	LF (mm)	CW (mm)	CUTDIA (mm)	kg	GI018	KV
R XLCFR 1612 H 03	16	16	12	100	3.00	40	0.14	GI018	KV
XLCFR 2016 K 03	20	20	16	130	3.00	50	0.30	GI018	KV
XLCFR 2520 K 03	25	25	20	130	3.00	50	0.44	GI018	KV
XLCFR 2016 K 04	20	20	16	130	4.00	50	0.30	GI019	KV
XLCFR 2520 K 04	25	25	20	130	4.00	50	0.43	GI019	KV
XLCFR 2520 K 05	25	25	20	130	5.00	50	0.45	GI020	KV
XLCFR 3225 P 05	32	32	25	170	5.00	65	0.90	GI020	KV
XLCFR 3225 P 06	32	32	25	170	6.00	65	0.91	GI021	KV
L XLCFL 1612 H 03	16	16	12	100	3.00	40	0.15	GI018	KV
XLCFL 2016 K 03	20	20	16	130	3.00	50	0.30	GI018	KV
XLCFL 2520 K 03	25	25	20	130	3.00	50	0.47	GI018	KV
XLCFL 2016 K 04	20	20	16	130	4.00	50	0.30	GI019	KV
XLCFL 2520 K 04	25	25	20	130	4.00	50	0.46	GI019	KV
XLCFL 2520 K 05	25	25	20	130	5.00	50	0.50	GI020	KV
XLCFL 3225 P 05	32	32	25	170	5.00	65	0.95	GI020	KV
XLCFL 3225 P 06	32	32	25	170	6.00	65	0.70	GI021	KV



GI018
GI019
GI020
GI021

LFUX 0308..
LFUX 0408..
LFUX 0508..
LFUX 0608..



KV

KV 5x70

XLCFN B LFUX

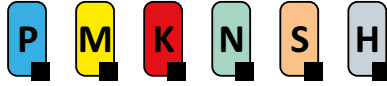

PRAMET

X

LFUX Uçlar için Çift Taraflı Kesme Laması

100mm derinlik ya da Ø200mm çapa kadar kesme işlemleri için lama. Çift taraflı LFUX uçlar için. 26, 32 veya 47mm yüksekliklerinde. DU, D Pramet baz tutuculara uygundur. Lama uzun takım ömrü için işlem görmüştür.

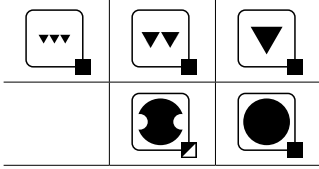
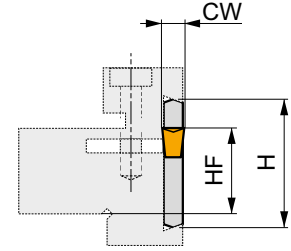
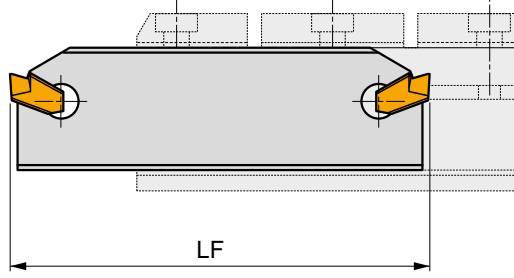
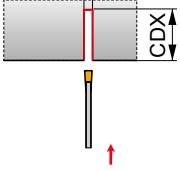

Product	≡ (mm)	H (mm)	LF (mm)	CW (mm)	CDX (mm)	kg	GI018	KV
XLCFN 2603 J 03	21.4	26	110	3.10	37.5	0.06	GI018	KV
XLCFN 3202 M 03	25	32	150	3.10	50	0.09	GI018	KV
XLCFN 3203 M 04	25	32	150	4.10	50	0.11	GI019	KV
XLCFN 3204 M 05	25	32	150	5.10	60	0.14	GI020	KV
XLCFN 4704 S 05	38	47	270	5.10	100	0.47	GI020	KV
XLCFN 4705 S 06	38	47	270	6.10	100	0.50	GI021	KV



GI018
GI019
GI020
GI021

LFUX 0308..
LFUX 0408..
LFUX 0508..
LFUX 0608..



KV

KV 5x70

DU, D**PRAMET****Kesme Lamaları için Takım Tutucu**

GL veya XLC. lamalar için tutucu. 20x20-40x40mm şaft ölçülerinde bulunur. Gövde uzun takım ömrü için işlem görmüştür.

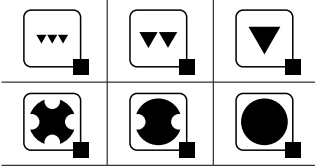
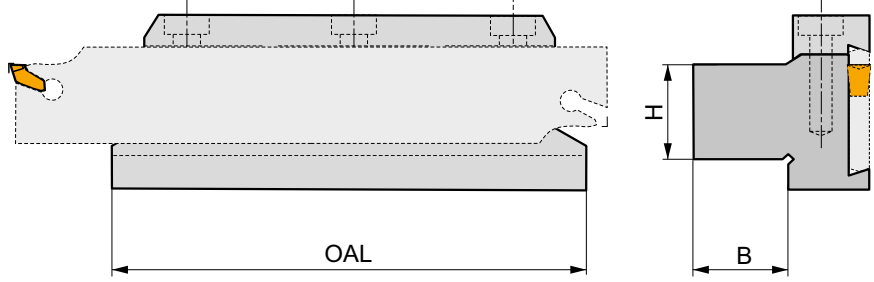
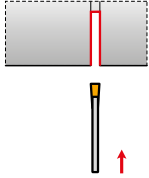

Product	H (mm)	B (mm)	OAL (mm)	kg		
26-DU 2020	20	20	90	0.70	GI007	ND2
26-D 2020	20	20	100	0.82	GI007	ND2
32-DU 2523	25	23	110	1.02	GI008	ND2
32-DU 2532	25	32	110	1.10	GI008	ND2
32-DU 3229	32	29	110	1.25	GI008	ND2
32-D 2530	25	30	115	1.30	GI008	ND2
45-DU 3229	32	29	110	1.50	GI009	ND7
45-DU 4036	40	36	110	2.05	GI009	ND7
47-D 4040	40	40	150	3.88	GI091	ND3

GI007	XLC.N 26..	GL.-S26.B
GI008	XLC.N 32..	GL.-S32.B
GI009	XLC.N 45..	-
GI091	XLC.N 47..	-

ND2	HS 0625	6.0	M 6	25	HXK 5	
ND3	HS 1030	8.0	M 10	30	HXK 8	
ND7	HS 0630	6.0	M 6	30	HXK 5	

NEW**X 61**

PRAMET

	W1	CWTOLL	CWTOLU	S
	(mm)	(mm)	(mm)	(mm)
0602	6.350	-0.03	0.03	2.33

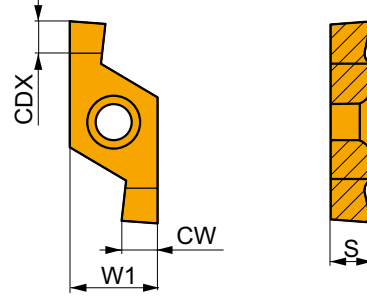

Kesme hızı (vc), ilerleme (f) için uygunluk ve başlangıç değerleri. Daha ileri hesaplamalar için İşleme Hesaplayıcısı uygulamasına başvurun.

Product	RE	P		M		K		N		S		H		CW	CDX
		vc	f	vc	f	vc	f	vc	f	vc	f	vc	f		
	(mm)	(m/min)	(mm/rev)	(m/min)	(mm/rev)	(m/min)	(mm/rev)	(m/min)	(mm/rev)	(m/min)	(mm/rev)	(m/min)	(mm/rev)	(mm)	(mm)

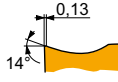

X 61-L dış ve iç, sağ kesme yönlü, o-ring ve segman kanalı işlemek için, darbesiz kesim.



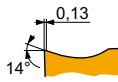











X61 0602-080 R	6640	-	195	0.06	115	0.05	185	0.06	-	-	-	-	-	0.85	0.8
	G8330	-	145	0.06	85	0.05	135	0.06	-	-	-	-	-	0.85	0.8
X61 0602-090 R	6640	-	195	0.06	115	0.05	185	0.06	-	-	-	-	-	0.95	0.8
	G8330	-	145	0.06	85	0.05	135	0.06	-	-	-	-	-	0.95	0.8
X61 0602-100 R	6640	-	195	0.06	115	0.05	185	0.06	-	-	-	-	-	1.05	0.8
	G8330	-	145	0.06	85	0.05	135	0.06	-	-	-	-	-	1.05	0.8
X61 0602-110 R	6640	-	185	0.06	110	0.05	175	0.06	-	-	-	-	-	1.15	1.2
	G8330	-	140	0.06	80	0.05	130	0.06	-	-	-	-	-	1.15	1.2
X61 0602-130 R	6640	-	185	0.06	110	0.05	175	0.06	-	-	-	-	-	1.35	1.4
	G8330	-	140	0.06	80	0.05	130	0.06	-	-	-	-	-	1.35	1.4
X61 0602-150 R	6640	-	180	0.06	105	0.05	170	0.06	-	-	-	-	-	1.55	1.6
	G8330	-	135	0.06	80	0.05	125	0.06	-	-	-	-	-	1.55	1.6
X61 0602-160 R	6640	-	180	0.06	105	0.05	170	0.06	-	-	-	-	-	1.65	1.7
	G8330	-	135	0.06	80	0.05	125	0.06	-	-	-	-	-	1.65	1.7
X61 0602-185 R	6640	-	150	0.09	90	0.08	140	0.09	-	-	-	-	-	1.90	2
	G8330	-	120	0.09	70	0.08	110	0.09	-	-	-	-	-	1.90	2
X61 0602-200 R	G8330	-	115	0.09	65	0.08	105	0.09	-	-	-	-	-	2.05	2.2
X61 0602-215 R	6640	-	145	0.09	85	0.08	135	0.09	-	-	-	-	-	2.20	2.4
	G8330	-	115	0.09	65	0.08	105	0.09	-	-	-	-	-	2.20	2.4
X61 0602-250 R	G8330	-	115	0.09	65	0.08	105	0.09	-	-	-	-	-	2.55	2.6
X61 0602-265 R	6640	-	125	0.12	75	0.11	115	0.12	-	-	-	-	-	2.70	2.7
	G8330	-	105	0.12	60	0.11	95	0.12	-	-	-	-	-	2.70	2.7
X61 0602-300 R	6640	-	125	0.12	75	0.11	115	0.12	-	-	-	-	-	3.05	3
	G8330	-	105	0.12	60	0.11	95	0.12	-	-	-	-	-	3.05	3
X61 0602-315 R	6640	-	125	0.12	75	0.11	115	0.12	-	-	-	-	-	3.20	3
	G8330	-	105	0.12	60	0.11	95	0.12	-	-	-	-	-	3.20	3



X 61-L dış ve iç, sol kesme yönlü, o-ring ve segman kanalı işlemek için, darbesiz kesim.

X61 0602-080 L	6640	-	195	0.06	115	0.05	185	0.06	-	-	-	-	-	0.85	0.8
	G8330	-	145	0.06	85	0.05	135	0.06	-	-	-	-	-	0.85	0.8
X61 0602-090 L	6640	-	195	0.06	115	0.05	185	0.06	-	-	-	-	-	0.95	0.8
	G8330	-	145	0.06	85	0.05	135	0.06	-	-	-	-	-	0.95	0.8
X61 0602-100 L	6640	-	195	0.06	115	0.05	185	0.06	-	-	-	-	-	1.05	0.8
	G8330	-	145	0.06	85	0.05	135	0.06	-	-	-	-	-	1.05	0.8
X61 0602-110 L	6640	-	185	0.06	110	0.05	175	0.06	-	-	-	-	-	1.15	1.2
	G8330	-	140	0.06	80	0.05	130	0.06	-	-	-	-	-	1.15	1.2
X61 0602-130 L	6640	-	185	0.06	110	0.05	175	0.06	-	-	-	-	-	1.35	1.4
	G8330	-	140	0.06	80	0.05	130	0.06	-	-	-	-	-	1.35	1.4

Kesme hızı (vc), ilerleme (f) için uygunluk ve başlangıç değerleri. Daha ileri hesaplamalar için İşleme Hesaplayıcısı uygulamasına başvurun.

Product	RE (mm)	P		M		K		N		S		H		CW (mm)	CDX (mm)	
		vc (m/min)	f (mm/rev)	vc (m/min)	f (mm/rev)	vc (m/min)	f (mm/rev)	vc (m/min)	f (mm/rev)	vc (m/min)	f (mm/rev)	vc (m/min)	f (mm/rev)			
	0.13	14°			X 61-L dış ve iç, sol kesme yönlü, o-ring ve segman kanalı işlemek için, darbesiz kesim.											
			6640	–	■	180	0.06	■	105	0.05	■	170	0.06	–	–	–
X61 0602-160 L	0.13	14°			X 61-L dış ve iç, sol kesme yönlü, o-ring ve segman kanalı işlemek için, darbesiz kesim.											
			G8330	–	■	135	0.06	■	80	0.05	■	125	0.06	–	–	–
X61 0602-185 L	0.13	14°			X 61-L dış ve iç, sol kesme yönlü, o-ring ve segman kanalı işlemek için, darbesiz kesim.											
			G8330	–	■	135	0.06	■	80	0.05	■	125	0.06	–	–	–
X61 0602-200 L	0.13	14°			X 61-L dış ve iç, sol kesme yönlü, o-ring ve segman kanalı işlemek için, darbesiz kesim.											
			G8330	–	■	150	0.09	■	90	0.08	■	140	0.09	–	–	–
X61 0602-215 L	0.13	14°			X 61-L dış ve iç, sol kesme yönlü, o-ring ve segman kanalı işlemek için, darbesiz kesim.											
			G8330	–	■	120	0.09	■	70	0.08	■	110	0.09	–	–	–
X61 0602-250 L	0.13	14°			X 61-L dış ve iç, sol kesme yönlü, o-ring ve segman kanalı işlemek için, darbesiz kesim.											
			G8330	–	■	115	0.09	■	65	0.08	■	105	0.09	–	–	–
X61 0602-265 L	0.13	14°			X 61-L dış ve iç, sol kesme yönlü, o-ring ve segman kanalı işlemek için, darbesiz kesim.											
			G8330	–	■	145	0.09	■	85	0.08	■	135	0.09	–	–	–
X61 0602-300 L	0.13	14°			X 61-L dış ve iç, sol kesme yönlü, o-ring ve segman kanalı işlemek için, darbesiz kesim.											
			G8330	–	■	115	0.09	■	65	0.08	■	105	0.09	–	–	–
X61 0602-315 L	0.13	14°			X 61-L dış ve iç, sol kesme yönlü, o-ring ve segman kanalı işlemek için, darbesiz kesim.											
			G8330	–	■	125	0.12	■	75	0.11	■	115	0.12	–	–	–
X61 0602-265 L	0.13	14°			X 61-L dış ve iç, sol kesme yönlü, o-ring ve segman kanalı işlemek için, darbesiz kesim.											
			G8330	–	■	105	0.12	■	60	0.11	■	95	0.12	–	–	–
X61 0602-300 L	0.13	14°			X 61-L dış ve iç, sol kesme yönlü, o-ring ve segman kanalı işlemek için, darbesiz kesim.											
			G8330	–	■	125	0.12	■	75	0.11	■	115	0.12	–	–	–
X61 0602-315 L	0.13	14°			X 61-L dış ve iç, sol kesme yönlü, o-ring ve segman kanalı işlemek için, darbesiz kesim.											
			G8330	–	■	105	0.12	■	60	0.11	■	95	0.12	–	–	–
X61 0602-315 L	0.13	14°			X 61-L dış ve iç, sol kesme yönlü, o-ring ve segman kanalı işlemek için, darbesiz kesim.											
			G8330	–	■	125	0.12	■	75	0.11	■	115	0.12	–	–	–
X61 0602-315 L	0.13	14°			X 61-L dış ve iç, sol kesme yönlü, o-ring ve segman kanalı işlemek için, darbesiz kesim.											
			G8330	–	■	105	0.12	■	60	0.11	■	95	0.12	–	–	–

NEW







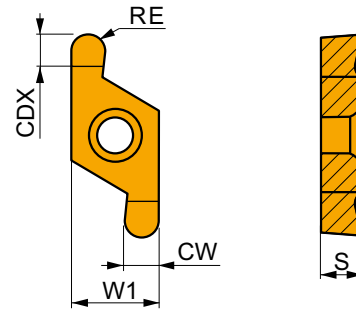



X 61 R

PRAMET

	W1 (mm)	CWTOLL (mm)	CWTOLU (mm)	S (mm)
0602	6.350	-0.03	0.03	2.33



Kesme hızı (vc), ilerleme (f) için uygunluk ve başlangıç değerleri. Daha ileri hesaplamalar için İşleme Hesaplayıcısı uygulamasına başvurun.

Product	RE (mm)	P		M		K		N		S		H		CW (mm)	CDX (mm)	
		vc (m/min)	f (mm/rev)	vc (m/min)	f (mm/rev)	vc (m/min)	f (mm/rev)	vc (m/min)	f (mm/rev)	vc (m/min)	f (mm/rev)	vc (m/min)	f (mm/rev)			
	1.0	13°			X 61 R-R dış ve iç, sağ kesme yönlü, o-ring ve segman kanalı işlemek için, darbesiz kesim.											
			6640	1.0	■	170	0.06	■	100	0.05	■	160	0.06	–	–	–
X61 0602-R150 R	1.5	13°			X 61 R-R dış ve iç, sağ kesme yönlü, o-ring ve segman kanalı işlemek için, darbesiz kesim.											
			G8330	1.0	■	130	0.06	■	75	0.05	■	120	0.06	–	–	–
X61 0602-R150 R	1.5	13°			X 61 R-R dış ve iç, sağ kesme yönlü, o-ring ve segman kanalı işlemek için, darbesiz kesim.											
			G8330	1.5	■	170	0.06	■	100	0.05	■	160	0.06	–	–	–
X61 0602-R150 R	1.5	13°			X 61 R-R dış ve iç, sağ kesme yönlü, o-ring ve segman kanalı işlemek için, darbesiz kesim.											
			G8330	1.5	■	130	0.06	■	75	0.05	■	120	0.06	–	–	–
	1.0	13°			X 61 R-L dış ve iç, sol kesme yönlü, o-ring ve segman kanalı işlemek için, darbesiz kesim.											
			6640	1.0	■	170	0.06	■	100	0.05	■	160	0.06	–	–	–
X61 0602-R150 L	1.5	13°			X 61 R-L dış ve iç, sol kesme yönlü, o-ring ve segman kanalı işlemek için, darbesiz kesim.											
			G8330	1.0	■	130	0.06	■	75	0.05	■	120	0.06	–	–	–
X61 0602-R150 L	1.5	13°			X 61 R-L dış ve iç, sol kesme yönlü, o-ring ve segman kanalı işlemek için, darbesiz kesim.											
			G8330	1.5	■	170	0.06	■	100	0.05	■	160	0.06	–	–	–
X61 0602-R150 L	1.5	13°			X 61 R-L dış ve iç, sol kesme yönlü, o-ring ve segman kanalı işlemek için, darbesiz kesim.											
			G8330	1.5	■	130	0.06	■	75	0.05	■	120	0.06	–	–	–

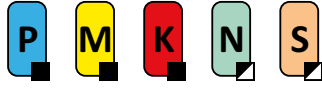
NEW**P61(RL) EXT**

PRAMET

S**X61 Segman ve O-ring Ucu için Dış Kanal Kateri**

Çift taraflı X61 O-ring ve segman uçları için Sağ/Sol radyal dış kanal kateri. Yüksek toleranslı ölçüler için pürüzsüz kesme sağlar. 16x16-25x25 şaft ölçülerinde bulunur. Gövde uzun takım ömrü için işlem görmüştür.

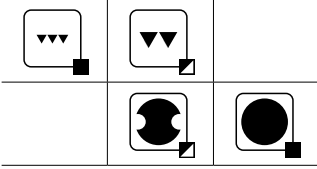
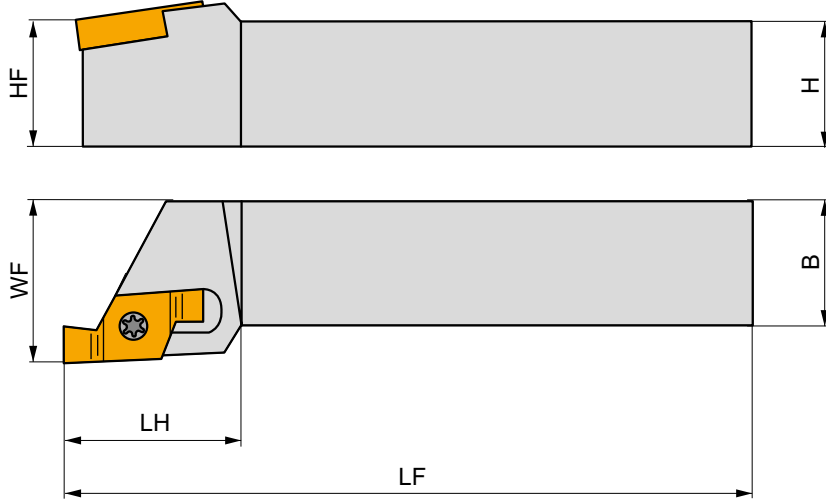
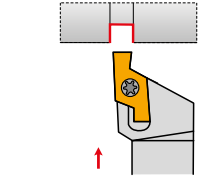

Product	HF (mm)	H (mm)	B (mm)	WF (mm)	LF (mm)	H (mm)	kg	GI332	SV11
R P61.SFR-1616H-06	16	16	16	20	100	21	0.23	GI332	SV11
P61.SFR-2020K-06	20	20	20	25	125	25	0.40	GI332	SV11
P61.SFR-2525M-06	25	25	25	32	150	32	0.73	GI332	SV11
L P61.SFL-1616H-06	16	16	16	20	100	21	0.23	GI332	SV11
P61.SFL-2020K-06	20	20	20	25	125	25	0.42	GI332	SV11
P61.SFL-2525M-06	25	25	25	32	150	32	0.73	GI332	SV11



GI332



X61 0602..



SV11



US 2003-T07P



0.8



M 2.5



6.5



FLAGT07P

NEW**P61(RL) INT**

PRAMET

S**X61 Uç için Segman Delik Kateri**

Çift taraflı X61 uçlar için Sağ/Sol delik kanal kateri. Minimum kanal açma çapı Ø16mm. Delik içi O-ring ve segman kanalı açma için uygundur. Ø12-32mm shaft ölçülerinde bulunur. Gövde uzun takım ömrü için işlem görmüştür.

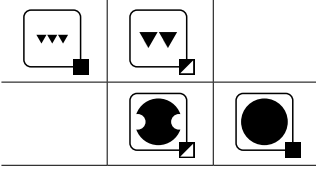
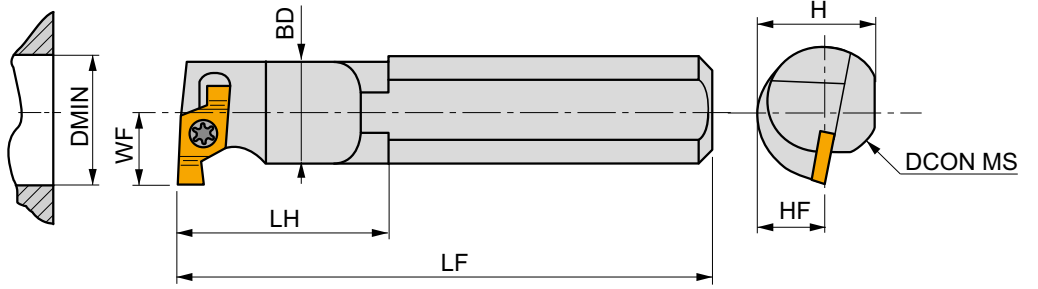
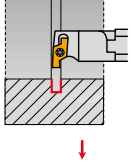

Product	DCON MS (mm)	DMIN (mm)	BD (mm)	WF (mm)	H (mm)	LF (mm)	LH (mm)	KAPR (°)					
R	P61.SGR-0012M-06	12	16	11.5	9	11	150	22	0	-	0.17	G332	SV11
	P61.SGR-A-0016M-06	16	20	15	11	15	150	29	0	✓	0.21	G332	SV11
	P61.SGR-A-0020P-06	20	25	19	13	18	170	29	0	✓	0.38	G332	SV11
	P61.SGR-A-0025R-06	25	32	24	17	23	200	31	0	✓	0.70	G332	SV11
	P61.SGR-A-0032T-06	32	40	31	22	30	300	49	0	✓	1.72	G332	SV11
L	P61.SGL-0012M-06	12	16	11.5	9	11	150	22	0	-	0.17	G332	SV11
	P61.SGL-A-0016M-06	16	20	15	11	15	150	29	0	✓	0.24	G332	SV11
	P61.SGL-A-0020P-06	20	25	19	13	18	170	29	0	✓	0.40	G332	SV11
	P61.SGL-A-0025R-06	25	32	24	17	23	200	31	0	✓	0.72	G332	SV11
	P61.SGL-A-0032T-06	32	40	31	22	30	300	49	0	✓	1.72	G332	SV11



G332



X61 0602..



SV11



US 2003-T07P



0.8



M 2.5



6.5



FLAG T07P

Sağ delik kateri için sol uç.

NEW**X 61-1**

PRAMET

	W1	CWTOLL	CWTOLU	S
	(mm)	(mm)	(mm)	(mm)
0602	6.350	-0.03	0.03	2.33

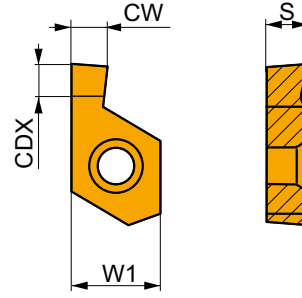

Kesme hızı (vc), ilerleme (f) için uygunluk ve başlangıç değerleri. Daha ileri hesaplamalar için İşleme Hesaplayıcısı uygulamasına başvurun.

Product	RE	P		M		K		N		S		H		CW	CDX
		vc	f	vc	f	vc	f	vc	f	vc	f	vc	f		
	(mm)	(m/min)	(mm/rev)	(m/min)	(mm/rev)	(m/min)	(mm/rev)	(m/min)	(mm/rev)	(m/min)	(mm/rev)	(m/min)	(mm/rev)	(mm)	(mm)

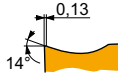

X 61-1-L iç, sağ kesme yönlü, tek ağızlı, o-ring ve segman kanalı işlemek için, darbesiz kesim.

X61 0602-080 R1	6640	-	195	0.06	115	0.05	185	0.06	-	-	-	-	-	0.85	0.8
X61 0602-090 R1	6640	-	195	0.06	115	0.05	185	0.06	-	-	-	-	-	0.95	0.8
X61 0602-110 R1	6640	-	185	0.06	110	0.05	175	0.06	-	-	-	-	-	1.15	1.2
X61 0602-130 R1	6640	-	185	0.06	110	0.05	175	0.06	-	-	-	-	-	1.35	1.4
X61 0602-160 R1	6640	-	180	0.06	105	0.05	170	0.06	-	-	-	-	-	1.65	1.7
X61 0602-185 R1	6640	-	150	0.09	90	0.08	140	0.09	-	-	-	-	-	1.90	2
X61 0602-215 R1	6640	-	145	0.09	85	0.08	135	0.09	-	-	-	-	-	2.20	2.2

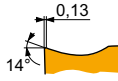

X 61-1-L iç, sol kesme yönlü, tek ağızlı, o-ring ve segman kanalı işlemek için, darbesiz kesim.

X61 0602-080 L1	6640	-	195	0.06	115	0.05	185	0.06	-	-	-	-	-	0.85	0.8
X61 0602-090 L1	6640	-	195	0.06	115	0.05	185	0.06	-	-	-	-	-	0.95	0.8
X61 0602-110 L1	6640	-	185	0.06	110	0.05	175	0.06	-	-	-	-	-	1.15	1.2
X61 0602-130 L1	6640	-	185	0.06	110	0.05	175	0.06	-	-	-	-	-	1.35	1.4
X61 0602-160 L1	6640	-	180	0.06	105	0.05	170	0.06	-	-	-	-	-	1.65	1.7
X61 0602-185 L1	6640	-	150	0.09	90	0.08	140	0.09	-	-	-	-	-	1.90	2
X61 0602-215 L1	6640	-	145	0.09	85	0.08	135	0.09	-	-	-	-	-	2.20	2.2

NEW**X 61 R-1****PRAMET**

	W1	CWTOLL	CWTOLU	S
	(mm)	(mm)	(mm)	(mm)
0602	6.350	-0.03	0.03	2.33

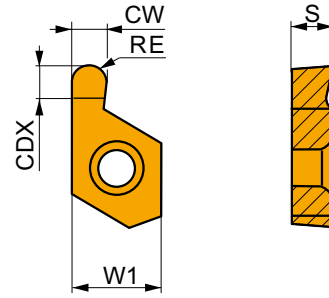

Kesme hızı (vc), ilerleme (f) için uygunluk ve başlangıç değerleri. Daha ileri hesaplamalar için İşleme Hesaplayıcısı uygulamasına başvurun.

Product	RE (mm)	P		M		K		N		S		H		CW (mm)	CDX (mm)
		vc (m/min)	f (mm/rev)	vc (m/min)	f (mm/rev)	vc (m/min)	f (mm/rev)	vc (m/min)	f (mm/rev)	vc (m/min)	f (mm/rev)	vc (m/min)	f (mm/rev)		



X 61 R-1-L iç, sağ kesme yönlü, tek ağızlı, o-ring ve segman kanalı işlemek için, darbesiz kesim.

X61 0602-R050 R1	6640	0.5	■ 185	0.06	■ 110	0.05	■ 175	0.06	–	–	–	–	–	1.09	1.3
X61 0602-R100 R1	6640	1.0	■ 170	0.06	■ 100	0.05	■ 160	0.06	–	–	–	–	–	2.09	2.8



X 61 R-1-L iç, sol kesme yönlü, tek ağızlı, o-ring ve segman kanalı işlemek için, darbesiz kesim.

X61 0602-R050 L1	6640	0.5	■ 185	0.06	■ 110	0.05	■ 175	0.06	–	–	–	–	–	1.09	1.3
X61 0602-R100 L1	6640	1.0	■ 170	0.06	■ 100	0.05	■ 160	0.06	–	–	–	–	–	2.09	2.8

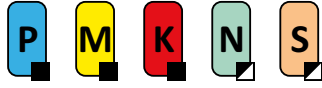
NEW**P61S(RL)-1 INT**

PRAMET

S**X61-1 Uç için Segman Delik Kateri**

Tek taraflı X61-1 uçlar için Sağ/Sol delik kanal kateri. Minimum kanal açma çapı $\varnothing 12.5\text{mm}$. Delik içi O-ring ve segman kanalı açma için uygundur. $\varnothing 10$ ve $\varnothing 12\text{mm}$ shaft ölçülerinde bulunur. Gövde uzun takım ömrü için işlem görmüştür.

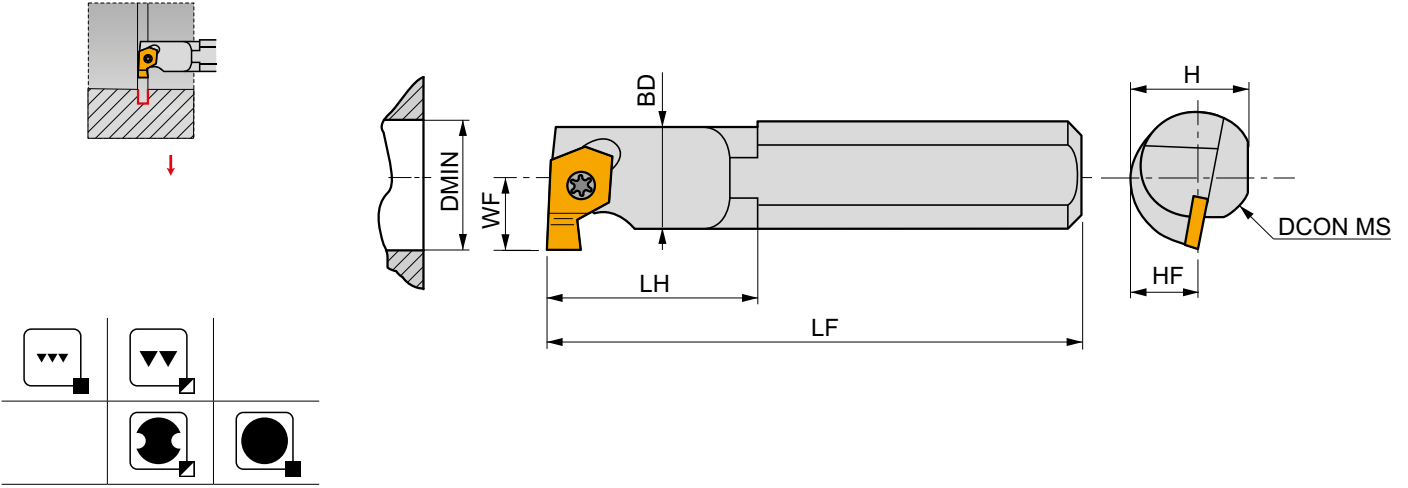

Product	DCON MS (mm)	DMIN (mm)	BD (mm)	WF (mm)	H (mm)	LF (mm)	LH (mm)	KAPR (°)	kg	G333	SV11
R P61.SGR-0010M-06/1	10	12.5	10	7.5	9	150	19	0	0.24	G333	SV11
P61.SGR-0012M-06/1	12	12.5	10	7.5	11	150	19	0	0.17	G333	SV11
L P61.SGL-0010M-06/1	10	12.5	10	7.5	9	150	19	0	0.13	G333	SV11
P61.SGL-0012M-06/1	12	12.5	10	7.5	11	150	19	0	0.17	G333	SV11



G333



X61 0602..-1



SV11



US 2003-T07P



0.8



M 2.5



6.5



FLAG T07P

Sağ delik kateri için sol uç.

TN R EXT

	IC	D1	S	CWTOLL	CWTOLU
	(mm)	(mm)	(mm)	(mm)	(mm)
16	9.525	3.90	3.58	0.00	0.05
22	12.700	4.90	4.70	0.00	0.05

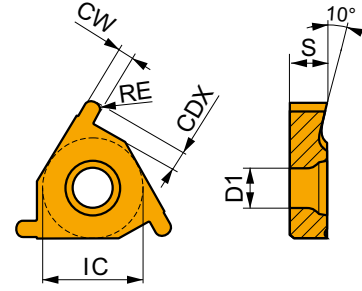

Kesme hızı (vc), ilerleme (f) için uygunluk ve başlangıç değerleri. Daha ileri hesaplamalar için İşleme Hesaplayıcısı uygulamasına başvurun.

Product	RE	P		M		K		N		S		H		CW	CDX
		vc	f	vc	f	vc	f	vc	f	vc	f	vc	f		
	(mm)	(m/min)	(mm/rev)	(m/min)	(mm/rev)	(m/min)	(mm/rev)	(m/min)	(mm/rev)	(m/min)	(mm/rev)	(m/min)	(mm/rev)	(mm)	(mm)



TN ER-R dış, sağ kesme yönlü, o-ring ve segman kanalı işlemek için, darbesiz kesim.

TN 16ER-R050	T8330	0.5	130	0.06	75	0.05	120	0.06	-	-	-	-	1.00	1.3
TN 16ER-R100	T8330	1.0	130	0.06	75	0.05	120	0.06	-	-	-	-	2.00	1.85
TN 22ER-R150	T8330	1.5	130	0.06	75	0.05	120	0.06	-	-	-	-	3.00	2.2



TN EL-R dış, sol kesme yönlü, o-ring ve segman kanalı işlemek için, darbesiz kesim.

TN 16EL-R050	T8330	0.5	130	0.06	75	0.05	120	0.06	-	-	-	-	1.00	1.3
TN 16EL-R100	T8330	1.0	130	0.06	75	0.05	120	0.06	-	-	-	-	2.00	1.85
TN 22EL-R150	T8330	1.5	130	0.06	75	0.05	120	0.06	-	-	-	-	3.00	2.2

TN R INT

	IC	D1	S	CWTOLL	CWTOLU
	(mm)	(mm)	(mm)	(mm)	(mm)
11	6.350	2.80	3.10	0.00	0.05
16	9.525	3.90	3.58	0.00	0.05
22	12.700	4.90	4.70	0.00	0.05

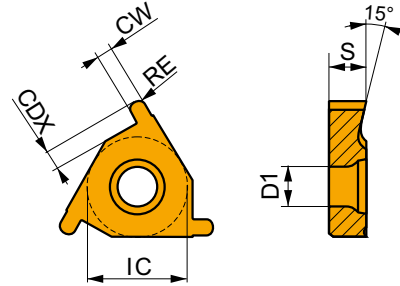

Kesme hızı (vc), ilerleme (f) için uygunluk ve başlangıç değerleri. Daha ileri hesaplamalar için İşleme Hesaplayıcısı uygulamasına başvurun.

Product	RE	P		M		K		N		S		H		CW	CDX
		vc	f	vc	f	vc	f	vc	f	vc	f	vc	f		
	(mm)	(m/min)	(mm/rev)	(m/min)	(mm/rev)	(m/min)	(mm/rev)	(m/min)	(mm/rev)	(m/min)	(mm/rev)	(m/min)	(mm/rev)	(mm)	(mm)



TN NR-R iç, sağ kesme yönlü, o-ring ve segman kanalı işlemek için, darbesiz kesim.

TN 11NR-R050	T8330	0.5	130	0.06	75	0.05	120	0.06	-	-	-	-	1.00	1.3
TN 16NR-R100	T8330	1.0	130	0.06	75	0.05	120	0.06	-	-	-	-	2.00	1.85
TN 22NR-R150	T8330	1.5	130	0.06	75	0.05	120	0.06	-	-	-	-	3.00	2.2

Kesme hızı (vc), ilerleme (f) için uygunluk ve başlangıç değerleri. Daha ileri hesaplamalar için İşleme Hesaplayıcısı uygulamasına başvurun.

Product	RE (mm)	P		M		K		N		S		H		CW (mm)	CDX (mm)
		vc (m/min)	f (mm/rev)	vc (m/min)	f (mm/rev)	vc (m/min)	f (mm/rev)	vc (m/min)	f (mm/rev)	vc (m/min)	f (mm/rev)	vc (m/min)	f (mm/rev)		

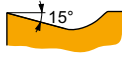

TN NL-R iç, sol kesme yönlü, o-ring ve segman kanalı işlemek için, darbesiz kesim.

TN 11NL-R050	T8330	0.5	130	0.06	75	0.05	120	0.06	-	-	-	-	-	1.00	1.3
TN 16NL-R100	T8330	1.0	130	0.06	75	0.05	120	0.06	-	-	-	-	-	2.00	1.85
TN 22NL-R150	T8330	1.5	130	0.06	75	0.05	120	0.06	-	-	-	-	-	3.00	2.2

TN ZZ EXT

PRAMET

	IC (mm)	D1 (mm)	S (mm)
16	9.525	3.90	3.40
22	12.700	4.90	4.70

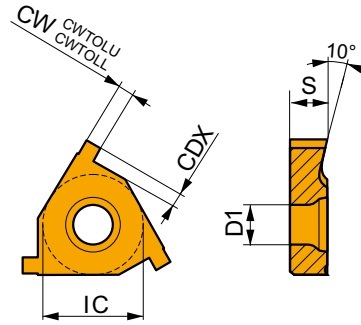

Kesme hızı (vc), ilerleme (f) için uygunluk ve başlangıç değerleri. Daha ileri hesaplamalar için İşleme Hesaplayıcısı uygulamasına başvurun.

Product	RE (mm)	P		M		K		N		S		H		CW (mm)	CWTOLL (mm)	CWTOLU (mm)	CDX (mm)
		vc (m/min)	f (mm/rev)	vc (m/min)	f (mm/rev)	vc (m/min)	f (mm/rev)	vc (m/min)	f (mm/rev)	vc (m/min)	f (mm/rev)	vc (m/min)	f (mm/rev)				



TN ER-ZZ dış, sağ kesme yönlü, o-ring ve segman kanalı işlemek için, darbesiz kesim.

TN 16ER090ZZ	T8330	-	130	0.09	75	0.08	120	0.09	-	-	-	-	-	0.90	0.05	0.10	0.9
TN 16ER110ZZ	T8330	-	130	0.09	75	0.08	120	0.09	-	-	-	-	-	1.10	0.05	0.10	1.3
TN 16ER130ZZ	T8330	-	130	0.09	75	0.08	120	0.09	-	-	-	-	-	1.30	0.05	0.10	1.6
TN 16ER160ZZ	T8330	-	130	0.09	75	0.08	120	0.09	-	-	-	-	-	1.60	0.05	0.10	1.85
TN 16ER185ZZ	T8330	-	130	0.09	75	0.08	120	0.09	-	-	-	-	-	1.85	0.05	0.10	1.85
TN 16ER215ZZ	T8330	-	130	0.09	75	0.08	120	0.09	-	-	-	-	-	2.15	0.05	0.10	1.85
TN 16ER265ZZ	T8330	-	130	0.12	75	0.11	120	0.12	-	-	-	-	-	2.65	0.05	0.10	2.05
TN 22ER265ZZ	T8330	-	130	0.12	75	0.11	120	0.12	-	-	-	-	-	2.65	0.08	0.13	2.2
TN 22ER315ZZ	T8330	-	130	0.12	75	0.11	120	0.12	-	-	-	-	-	3.15	0.08	0.13	2.2
TN 22ER415ZZ	T8330	-	130	0.12	75	0.11	120	0.12	-	-	-	-	-	4.15	0.08	0.13	2.4

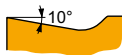

TN EL-ZZ dış, sol kesme yönlü, o-ring ve segman kanalı işlemek için, darbesiz kesim.

TN 16EL090ZZ	T8330	-	130	0.06	75	0.05	120	0.06	-	-	-	-	-	0.90	0.05	0.10	0.9
TN 16EL110ZZ	T8330	-	130	0.06	75	0.05	120	0.06	-	-	-	-	-	1.10	0.05	0.10	1.3
TN 16EL130ZZ	T8330	-	130	0.06	75	0.05	120	0.06	-	-	-	-	-	1.30	0.05	0.10	1.6
TN 16EL160ZZ	T8330	-	130	0.06	75	0.05	120	0.06	-	-	-	-	-	1.60	0.05	0.10	1.85
TN 16EL185ZZ	T8330	-	130	0.06	75	0.05	120	0.06	-	-	-	-	-	1.85	0.05	0.10	1.85
TN 16EL215ZZ	T8330	-	130	0.09	75	0.08	120	0.09	-	-	-	-	-	2.15	0.05	0.10	1.85
TN 16EL265ZZ	T8330	-	130	0.09	75	0.08	120	0.09	-	-	-	-	-	2.65	0.05	0.10	2.05
TN 22EL265ZZ	T8330	-	130	0.12	75	0.11	120	0.12	-	-	-	-	-	2.65	0.08	0.13	2.2
TN 22EL315ZZ	T8330	-	130	0.12	75	0.11	120	0.12	-	-	-	-	-	3.15	0.08	0.13	2.2
TN 22EL415ZZ	T8330	-	130	0.12	75	0.11	120	0.12	-	-	-	-	-	4.15	0.08	0.13	2.4

TN ZZ INT

	IC	D1	S
	(mm)	(mm)	(mm)
11	6.350	2.80	3.00
16	9.525	3.90	3.40
22	12.700	4.90	4.70

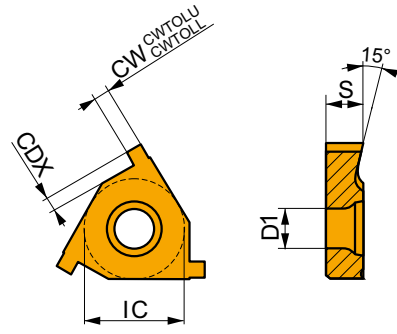

Kesme hızı (vc), ilerleme (f) için uygunluk ve başlangıç değerleri. Daha ileri hesaplamalar için İşleme Hesaplayıcısı uygulamasına başvurun.

Product	RE	P		M		K		N		S		H		CW	CWTOLL	CWTOLU	CDX
		vc	f	vc	f	vc	f	vc	f	vc	f	vc	f				
	(mm)	(m/min)	(mm/rev)	(m/min)	(mm/rev)	(m/min)	(mm/rev)	(m/min)	(mm/rev)	(m/min)	(mm/rev)	(m/min)	(mm/rev)	(mm)	(mm)	(mm)	(mm)



TN NR-ZZ iç, sağ kesme yönlü, o-ring ve segman kanalı işlemek için, darbesiz kesim.

TN 11NR090ZZ	T8330	-	■	130	0.06	■	75	0.05	■	120	0.06	-	-	-	-	0.90	0.05	0.10	0.9
TN 11NR110ZZ	T8330	-	■	130	0.06	■	75	0.05	■	120	0.06	-	-	-	-	1.10	0.05	0.10	1.3
TN 16NR090ZZ	T8330	-	■	130	0.06	■	75	0.05	■	120	0.06	-	-	-	-	0.90	0.05	0.10	0.9
TN 16NR110ZZ	T8330	-	■	130	0.06	■	75	0.05	■	120	0.06	-	-	-	-	1.10	0.05	0.10	1.3
TN 16NR130ZZ	T8330	-	■	130	0.06	■	75	0.05	■	120	0.06	-	-	-	-	1.30	0.05	0.10	1.6
TN 16NR160ZZ	T8330	-	■	130	0.06	■	75	0.05	■	120	0.06	-	-	-	-	1.60	0.05	0.10	1.85
TN 16NR185ZZ	T8330	-	■	130	0.06	■	75	0.05	■	120	0.06	-	-	-	-	1.85	0.05	0.10	1.85
TN 16NR215ZZ	T8330	-	■	130	0.09	■	75	0.08	■	120	0.09	-	-	-	-	2.15	0.05	0.10	1.85
TN 16NR265ZZ	T8330	-	■	130	0.12	■	75	0.11	■	120	0.12	-	-	-	-	2.65	0.05	0.10	2.05
TN 22NR265ZZ	T8330	-	■	130	0.12	■	75	0.11	■	120	0.12	-	-	-	-	2.65	0.08	0.13	2.2
TN 22NR315ZZ	T8330	-	■	130	0.12	■	75	0.11	■	120	0.12	-	-	-	-	3.15	0.08	0.13	2.2
TN 22NR415ZZ	T8330	-	■	130	0.12	■	75	0.11	■	120	0.12	-	-	-	-	4.15	0.08	0.13	2.4



TN NL-ZZ iç, sol kesme yönlü, o-ring ve segman kanalı işlemek için, darbesiz kesim.

TN 11NL090ZZ	T8330	-	■	130	0.06	■	75	0.05	■	120	0.06	-	-	-	-	0.90	0.05	0.10	0.9
TN 11NL110ZZ	T8330	-	■	130	0.06	■	75	0.05	■	120	0.06	-	-	-	-	1.10	0.05	0.10	1.3
TN 16NL090ZZ	T8330	-	■	130	0.06	■	75	0.05	■	120	0.06	-	-	-	-	0.90	0.05	0.10	0.9
TN 16NL110ZZ	T8330	-	■	130	0.06	■	75	0.05	■	120	0.06	-	-	-	-	1.10	0.05	0.10	1.3
TN 16NL130ZZ	T8330	-	■	130	0.06	■	75	0.05	■	120	0.06	-	-	-	-	1.30	0.05	0.10	1.6
TN 16NL160ZZ	T8330	-	■	130	0.06	■	75	0.05	■	120	0.06	-	-	-	-	1.60	0.05	0.10	1.85
TN 16NL185ZZ	T8330	-	■	130	0.06	■	75	0.05	■	120	0.06	-	-	-	-	1.85	0.05	0.10	1.85
TN 16NL215ZZ	T8330	-	■	130	0.09	■	75	0.08	■	120	0.09	-	-	-	-	2.15	0.05	0.10	1.85
TN 16NL265ZZ	T8330	-	■	130	0.09	■	75	0.08	■	120	0.09	-	-	-	-	2.65	0.05	0.10	2.05
TN 22NL265ZZ	T8330	-	■	130	0.12	■	75	0.11	■	120	0.12	-	-	-	-	2.65	0.08	0.13	2.2
TN 22NL315ZZ	T8330	-	■	130	0.12	■	75	0.11	■	120	0.12	-	-	-	-	3.15	0.08	0.13	2.2
TN 22NL415ZZ	T8330	-	■	130	0.12	■	75	0.11	■	120	0.12	-	-	-	-	4.15	0.08	0.13	2.4

SE(RL)

PRAMET

S**TN 16 veya 22 Uç için Vida Sıkmalı Dış Kateri**

TN16 veya 22 EN uçlar için Sağ/Sol dış kateri. Metrik veya inç profiller için uygundur. Ayrıca basit kanal açma işlemleri için de kullanılabilir. Gövde uzun takım ömrü için işlem görmüştür.

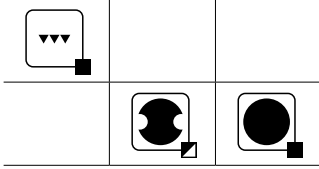
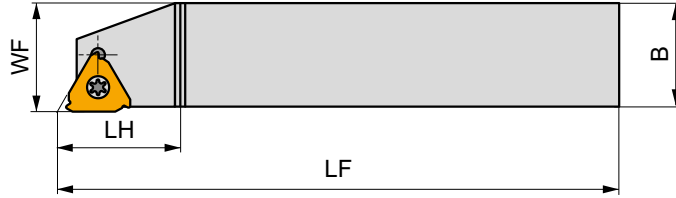
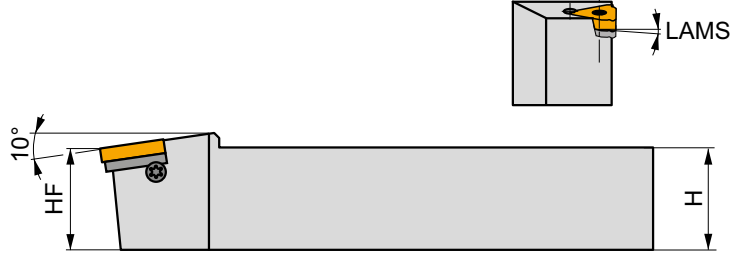
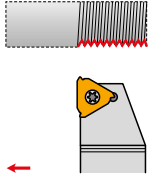

Product	H	H̄	B	WF	LF	H̄	LAMS		
	(mm)	(mm)	(mm)	(mm)	(mm)	(mm)	(°)		
R SER 2020 K 16	20	20	20	20	125	22.5	-	GI068	Z12
SER 2525 M 16	25	25	25	25	150	24	-	GI068	Z12
SER 3225 P 16	32	32	25	25	170	24.5	-	GI068	Z12
SER 2525 M 22-A	25	25	25	25	150	25.5	-	GI071	Z13
SER 3225 P 22-A	32	32	25	25	170	25.5	-	GI071	Z13
L SEL 2020 K 16	20	20	20	20	125	22.5	-	GI068	Z12
SEL 2525 M 16	25	25	25	25	150	24	-	GI068	Z12
SEL 3225 P 16	32	32	25	25	170	24.5	-	GI068	Z12
SEL 2525 M 22-A	25	25	25	25	150	25.5	-	GI071	Z13
SEL 3225 P 22-A	32	32	25	25	170	25.5	-	GI071	Z13

GI068	TN 16ER..	TN 16EL..
GI071	TN 22ER..	TN 22EL..

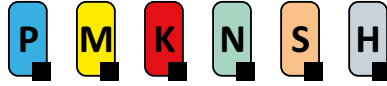

Z12	US 3512A-T15P	3.0	M 3.5	12.7	-	HS 0304	FLAG T15P	HXK 2.5	481
Z13	US 4514A-T20	5.0	M 4.5	14	SP 0405	-	FLAG T20	-	481



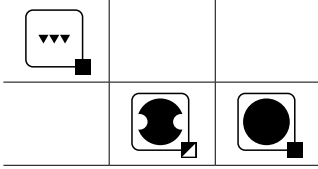
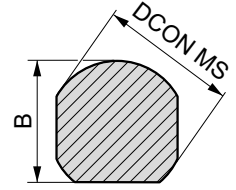
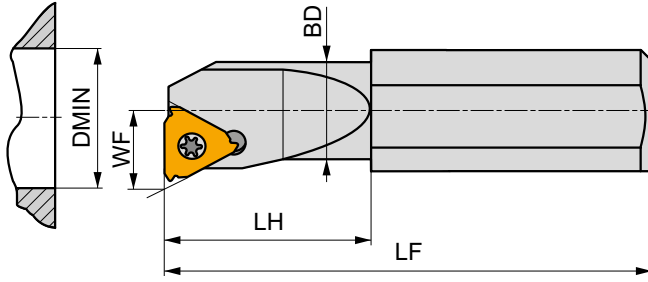
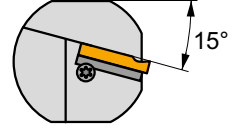
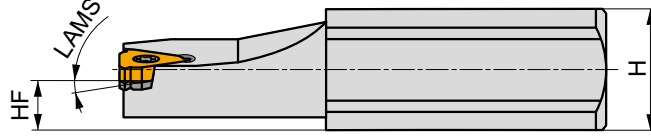
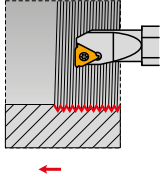









SI(RL)**PRAMET****S****TN 11, 16 veya 22 Uç için Vida Sıkmalı Dış Delik Kateri**

TN11, 16 veya 22 EN uçlar için Sağ/Sol delik dış kateri. Metrik veya inç profiller için uygundur. Minimum çalışma çapı Ø13mm. Ayrıca basit kanal açma işlemleri için de kullanılabilir. Ø16-40mm şaft ölçüleri. Gövde uzun takım ömrü için işlem görmüştür.



Product	B	DCON MS	DMIN	BD	WF	H	HF	LF	LH	LAMS			
	(mm)	(mm)	(mm)	(mm)	(mm)	(mm)	(mm)	(mm)	(mm)	(°)			
R SIR 0010 K 11-0	14.5	16	13	10	7.45	14	7	125	25	0	–	GI085	Z11
SIR 0010 K 11-1	14.5	16	13	10	7.45	14	7	125	25	1	–	GI085	Z11
SIR 0013 M 11-0	14.5	16	16	13	9	14	7	150	32	0	–	GI085	Z11
SIR 0013 M 11-1	14.5	16	16	13	9	14	7	150	32	1	–	GI085	Z11
SIR 1416 N 16-0	14	16	22	17	11.4	14.5	7.5	160	–	0	–	GI022	Z9
SIR 1416 N 16-1	14	16	22	17	11.4	14.5	7.5	160	–	1	–	GI022	Z9
SIR 1416 N 16-2	14	16	16.5	15.5	10.6	14.5	7.5	160	40	2	✓	GI022	Z10
SIR 1820 P 16	18.5	20	27	21	13.85	18	9	170	–	–	–	GI022	Z12
SIR 2325 Q 16	23.5	25	29	26	16.55	23	11.5	180	–	–	–	GI022	Z12
SIR 2532 S 16	30	32	36	32	19.75	25	12.5	250	–	–	–	GI022	Z12
SIR 2532 S 22-2	30	32	25	25	16.65	25	12.5	250	80	2	✓	GI076	Z14
SIR 2532 S 22-A	30	32	36	32	21.65	25	12.5	250	–	–	–	GI076	Z13
SIR 3240 T 22-A	38	40	48	40	25.85	32	16	300	–	–	–	GI076	Z13
L SIL 0010 K 11-0	14.5	16	13	10	7.45	14	7	125	25	0	–	GI085	Z11
SIL 0010 K 11-1	14.5	16	13	10	7.55	14	7	125	25	1	–	GI085	Z11
SIL 0013 M 11-0	14.5	16	16	13	9	14	7	150	32	0	–	GI085	Z11
SIL 0013 M 11-1	14.5	16	16	13	9	14	7	150	32	1	–	GI085	Z11
SIL 1416 N 16-0	14	16	22	17	11.4	14.5	7.5	160	–	0	–	GI022	Z9
SIL 1416 N 16-1	14	16	22	17	11.4	14.5	7.5	160	–	1	–	GI022	Z9
SIL 1416 N 16-2	14	16	16.5	15.5	10.6	14.5	7.5	160	40	2	✓	GI022	Z10
SIL 1820 P 16	18.5	20	27	21	13.85	18	9	170	–	–	–	GI022	Z12
SIL 2325 Q 16	23.5	25	29	26	16.55	23	11.5	180	–	–	–	GI022	Z12
SIL 2532 S 16	30	32	36	32	19.75	25	12.5	250	–	–	–	GI022	Z12
SIL 2532 S 22-2	30	32	25	25	16.65	25	12.5	250	80	2	✓	GI076	Z14
SIL 2532 S 22-A	30	32	36	32	21.65	25	12.5	250	–	–	–	GI076	Z13
SIL 3240 T 22-A	38	40	48	40	25.85	32	16	300	–	–	–	GI076	Z13

		
GI022	TN 16NR..	TN 16NL..
GI076	TN 22NR..	TN 22NL..
GI085	TN 11NR..	TN 11NL..

		 Nm							
Z10	US 3510A-T15P	3.0	M 3.5	10.6	-	-	FLAG T15P	-	-
Z11	US 2506-T07P	0.9	M 2.5	6.3	-	-	FLAG T07P	-	-
Z12	US 3512A-T15P	3.0	M 3.5	12.7	-	HS 0304	FLAG T15P	HXK 2.5	 481
Z13	US 4514A-T20	5.0	M 4.5	14	SP 0405	-	FLAG T20	-	 481
Z14	US 4514A-T20	5.0	M 4.5	14	-	-	FLAG T20	-	-
Z9	US 3510A-T15P	3.0	M 3.5	10.6	-	-	FLAG T15P	-	P-16

Altlık seçimi

Helis açısı λ	Pozitif					Negatif		Kanal uçları için TN16... ZZ, TN22... ZZ
	4.5°	3.5°	2.5°	1.5°	0.5°	-0.5°	-1.5°	
Tutucu	Altlık tanımı							
SER16; SIL16	PE16+4.5	PE16+3.5	PE16+2.5	PE16+1.5	PE16+0.5	PE16-0.5	PE16-1.5	PE16ZZ
SEL16; SIR16	PI16+4.5	PI16+3.5	PI16+2.5	PI16+1.5	PI16+0.5	PI16-0.5	PI16-1.5	PI16ZZ
SER22; SIL22	PE22+4.5	PE22+3.5	PE22+2.5	PE22+1.5	PE22+0.5	PE22-0.5	PE22-1.5	PE22ZZ
SEL22; SIR22	PI22+4.5	PI22+3.5	PI22+2.5	PI22+1.5	PI22+0.5	PI22-0.5	PI22-1.5	PI22ZZ
SER-S22; SIL-S22	PE22S+4.5	PE22S+3.5	PE22S+2.5	PE22S+1.5	PE22S+0.5	PE22S-0.5	PE22S-1.5	-
SEL-S22; SIR-S22	PI22S+4.5	PI22S+3.5	PI22S+2.5	PI22S+1.5	PI22S+0.5	PI22S-0.5	PI22S-1.5	-

Takım tutucular genellikle helis açısı $\lambda = 1.5^\circ$ olarak temin edilir. Altlık değiştirilerek farklı helis açısı seçilebilir.

Doğru altlık seçimi için aşağıdaki Tablo 16 ve ya Şekil Grafik 21'i kullanabilirsiniz. SER-S, SIR-S tutucuları için ayar sacları „S“ ile işaretlenmiştir.

**Diş
TORNALAMA**



6		İŞ PARÇASI MALZEME GRUPLARI (WMG) VE ISO 13399
10	ISO TORNALAMA	GENEL BİLGİLER
18		REHBER
57		POZİTİF KESİCİ UÇLAR
219		NEGATİF KESİCİ UÇLAR
386		KESME VE KANAL AÇMA
482		DİŞ TORNALAMA
528		BROŞLAMA
536		GENEL TEKNİK BİLGİLER

1 TN M INT

	IC [mm]	L [mm]	S [mm]
11	6.350	11.00	3.00
16	9.525	16.50	3.47
22	12.700	22.00	4.71

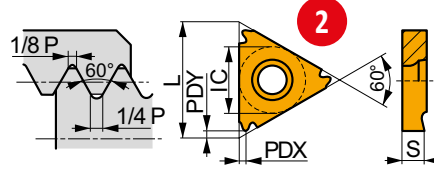

Kesme hızı (vc) için uygunluk ve başlangıç değerleri. Daha ileri hesaplamalar için İşleme Hesaplayıcısı uygulamasına başvurun.

Product	RE [mm]	P	M	K	N	S	H	TP [mm]	TPI	PDX [mm]	PDY [mm]
		vc [m/min]	vc [m/min]	vc [m/min]	vc [m/min]	vc [m/min]	vc [m/min]				

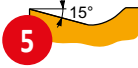

10 TN M NR iç, sağ kesme yönlü, ISO Metrik dişler için, darbesiz kesim.

TN 11NR050M	T8010	–	175	105	165	–	40	–	0.50	–	0.8	0.8
	T8030	–	160	95	150	–	40	–	0.50	–	0.8	0.8
TN 11NR075M	T8010	–	175	105	165	–	40	–	0.75	–	0.8	0.8
	T8030	–	160	95	150	480	40	–	0.75	–	0.8	0.8
TN 11NR100M	T8010	–	175	105	165	–	40	–	1.00	–	0.8	0.8
	T8030	–	160	95	150	480	40	–	1.00	–	0.8	0.8
TN 11NR125M	T8010	–	175	105	165	–	40	–	1.25	–	0.8	0.8
	T8030	–	160	95	150	480	40	–	1.25	–	0.8	0.8
TN 11NR150M	T8010	–	175	105	165	–	40	–	1.50	–	0.8	0.8
	T8030	–	160	95	150	480	40	–	1.50	–	0.8	0.8
TN 11NR200M	T8010	–	175	105	165	–	40	–	2.00	–	0.9	0.8
	T8030	–	160	95	150	480	40	–	2.00	–	0.9	0.8
TN 16NR050M	T8010	–	175	105	165	–	40	–	0.50	–	0.8	0.8
	T8030	–	160	95	150	480	40	–	0.50	–	0.8	0.8
TN 16NR075M	T8010	–	175	105	165	–	40	–	0.75	–	0.8	0.8
	T8030	–	160	95	150	480	40	–	0.75	–	0.8	0.8
TN 16NR100M	T8010	–	175	105	165	–	40	–	1.00	–	0.8	0.8
	T8030	–	160	95	150	480	40	–	1.00	–	0.8	0.8
TN 16NR125M	T8010	–	175	105	165	–	40	–	1.25	–	0.8	0.8

TN 16NR075M:T8010

Sipariş verirken kesici uç özellik kodunu tam olarak belirtin!

Kalite

İki nokta üst üste işaretini ekleyin

ISO kesici uç kodu

KESİCİ UÇLAR – GENEL BAKIŞ SAYFASI

Poz.	Açıklama	Poz.	Açıklama
1	Kesici ucun işareti	7	ISO kesici uç kodu
2	Kesici ucun şematik çizimi	8	Kalite
3	Kesici uç boyutları tablosu (mm)	9	Kesici uç yarıçapları (mm)
4	Temsili kesici ucun resmi	10	Geometri açıklaması
5	Ana Kesme kenarının profili	11	Kesici ucun uygulama alanı
6	Simgeler - spesifik özellikler ve kesme kenarı tipi		

DİŞ TORNALAMA TAKIMLARI – GENEL BAKIŞ SAYFASI

1 **SI(RL)**

P M K N S H 2

PRAMET 3 S



TN 11, 16 veya 22 Uç için Vida Sıkmalı Dış Delik Kateri

TN11, 16 veya 22 NR/NL uçlar için Sağ/Sol delik dış kateri. Metrik veya inç profiller için uygundur. Minimum çalışma çapı Ø13mm. Ayrıca basit kanal açma işlemleri için de kullanılabilir. Ø16-40mm shaft ölçüleri. Gövde uzun takım ömrü için işlem görmüştür.

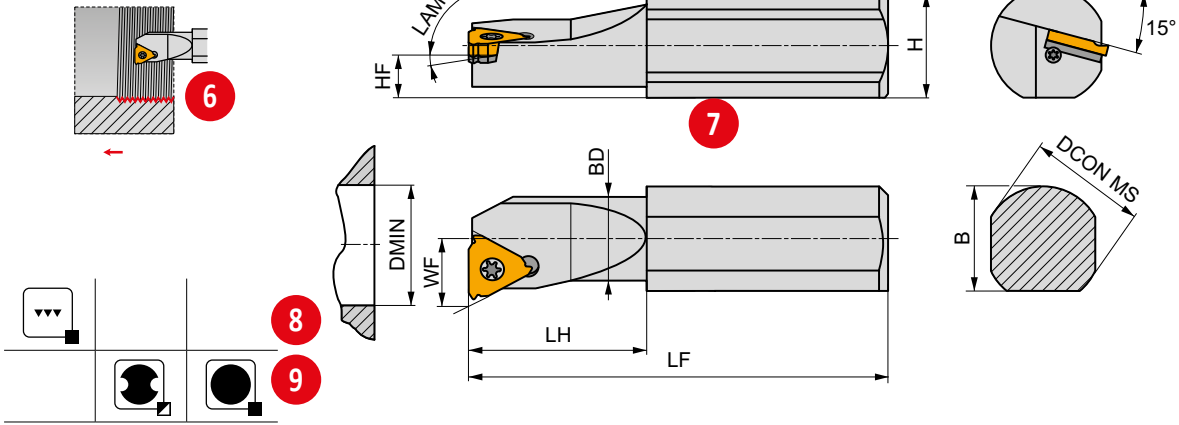

10

Product	B	DCON MS	DMIN	BD	WF	H	HF	LF	LH	LAMS				
	[mm]	[mm]	[mm]	[mm]	[mm]	[mm]	[mm]	[mm]	[mm]	[°]				
SIR 0010 K 11-0	14.5	16	13	10	7.45	14	7	125	25	0	–	GI085	Z11	
SIR 0010 K 11-1	14.5	16	13	10	7.45	14	7	125	25	1	–	GI085	Z11	
SIR 0013 M 11-0	14.5	16	16	13	9	14	7	150	32	0	–	GI085	Z11	
11 SIR 0013 12	14.5	16	16	13	9	14	7	150	32	1	–	14	15	16
SIR 1416 N 16-0	14	16	22	17	11.4	14.5	7.5	160	–	0	–	GI022	Z9	
SIR 1416 N 16-1	14	16	22	17	11.4	14.5	7.5	160	–	1	–	GI022	Z9	
R SIR 1416 N 16-2	14	16	16.5	15.5	10.6	14.5	7.5	160	40	2	✓	GI022	Z10	
SIR 1820 P 16	18.5	20	27	21	13.85	18	9	170	–	–	–	GI022	Z12	
SIR 2325 Q 16	23.5	25	29	26	16.55	23	11.5	180	–	–	–	GI022	Z12	
SIR 2532 S 16	30	32	36	32	19.75	25	12.5	250	–	–	–	GI022	Z12	
SIR 2532 S 22-2	30	32	25	25	16.65	25	12.5	250	80	2	✓	GI076	Z14	
SIR 2532 S 22-A	30	32	36	32	21.65	25	12.5	250	–	–	–	GI076	Z13	
SIR 3240 T 22-A	38	40	48	40	25.85	32	16	300	–	–	–	GI076	Z13	



17



GI022	TN 16NR..	TN 16NL..
GI076	TN 22NR..	TN 22NL..
GI085	TN 11NR..	TN 11NL..

		Nm			18				
Z10	US 3510A-T15P	3.0	M 3.5	10.6	–	–	FLAG T15P	–	–
Z11	US 2506-T07P	0.9	M 2.5	6.3	–	–	FLAG T07P	–	–
Z12	US 3512A-T15P	3.0	M 3.5	12.7	–	HS 0304	FLAG T15P	HXX 2.5	Page xx
Z13	US 4514A-T20	5.0	M 4.5	14	SP 0405	–	FLAG T20	–	Page xx
Z14	US 4514A-T20	5.0	M 4.5	14	–	–	FLAG T20	–	–
Z9	US 3510A-T15P	3.0	M 3.5	10.6	–	–	FLAG T15P	–	P-16

DİŞ TORNALAMA TAKIMLARI – GENEL BAKIŞ SAYFASI

Poz.	Açıklama
1	Diş tornalama tutucusunun işareti
2	Malzeme grubu önerileri
3	Kesici ucun bağlama sistemi
4	Açıklayıcı resim ¹⁾
5	Takım açıklaması
6	İş parçası profili
7	Takımın şematik çizimi
8	Ulaşılabilir yüzey kalitesi
9	Kesim karakteri/çalışma koşulları

Poz.	Açıklama
10	Ürün uygulamaları
11	Takım tasarımı
12	ISO tutucu kodu
13	Tutucunun ölçüleri [mm] ve açıları ²⁾ [°]
14	İçten kesme sıvısı beslemesi
15	Uyumlu kesici uç grubu ³⁾
16	Yedek parça grubu ^{3),4)}
17	Uyumlu kesici uçlar
18	Yedek parçalar

¹⁾ Resimlerde birincil olarak sağ kesme yönlü (R) takım gösterilmiştir.

²⁾ GAMO = ortogonal açı (bkz. teknik bölüm)









LAMS = Ana kesici kenar eğim açısı (bkz. teknik bölüm)

³⁾ Uyumlu kesici uçlar, yedek parçalar ve özel aksesuarlar kodlama grubu sadece katalog amaçlıdır ve siparişler için kullanılamaz.

⁴⁾ Yedek parçaların ve özel aksesuarların simgeleri kolay anlaşılabilmesi için şematik olarak tasarlanmıştır. Bazı durumlarda vidalar Nm tork moment, vida boyu ve diş ölçüsü bilgileri ile tamamlanmıştır.

DİŞ TORNALAMA – SİMGELERE GENEL BAKIŞ

GENEL SİMGELER

 Birincil kullanım	 Finiş işleme – çok iyi yüzey kalitesi	 Stabil çalışma koşullarına uygun
 Olası kullanım	 Orta talaş işleme – iyi yüzey kalitesi	 Stabil olmayan çalışma koşullarına uygun
	 Kaba talaş işleme – sınırlanmamış yüzey pürüzlülüğü	 Çok dengesiz çalışma koşullarına uygun

ÖZELLİKLER

 Diş Tornalama – dış çap	 Diş Tornalama – iç çap
--	--

KAPLAMA

 İlk tercih	 Üniversal geniş aralık seçeneği	 Keskin kenar
 Sert malzemeler için (uzun talaş oluşturan)	 Yuvarlatılmış kenar	

DİĞER

 Vidanın bağlama torku [Nm]	 İçten kesme sıvısı beslemesi
---	--

M

Tam profil

TN M EXT *NEW*

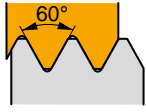

495

TN M INT *NEW*

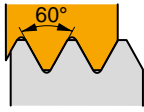

497

M

Kısmi profil

TN 60° PP EXT

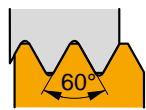

499

TN 60° PP INT

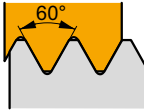

500

TN 60°-S PP EXT

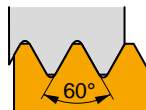

501

TN 60°-S PP INT

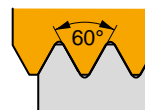

501

MJ

Tam profil

TN MJ EXT *NEW*

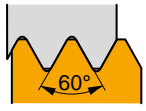

499

UN

Tam profil

TN UN EXT

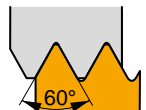

502

TN UN INT

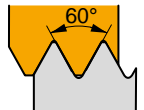

503

UNJ

Tam profil

TN UNJ EXT *NEW*

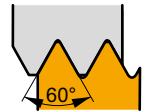

504

W

Tam profil

TN W EXT

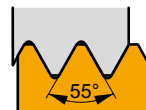

505

TN W INT

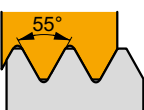

506

W

Kısmi profil

TN 55° PP EXT

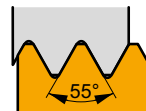

508

TN 55° PP INT

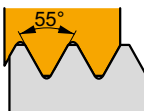

509

BSPT

Tam profil

TN BSPT EXT

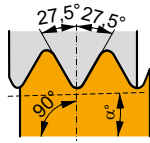

510

TN BSPT INT

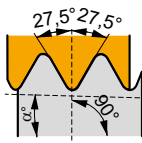

510

NPT

Tam profil

TN NPT EXT

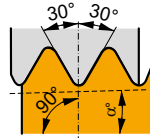

511

TN NPT INT

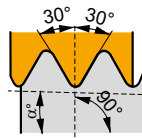

512

TR

Tam profil

TN TR EXT

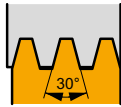

512

TN TR INT

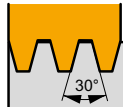

513

TN TR-S EXT

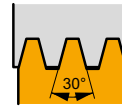

514

TN TR-S INT

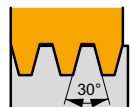

514

ACME

Tam profil

TN ACME EXT

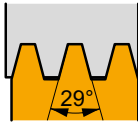

515

TN ACME INT

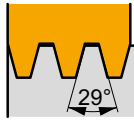

516

STACME

Tam profil

TN STACME EXT **NEW**

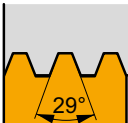

517

TN STACME INT **NEW**

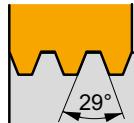

518

API RD

Tam profil

TN API RD EXT

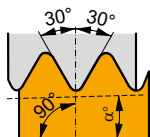

519

TN API RD INT

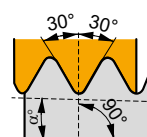

519

RD

Tam profil

TN RD EXT

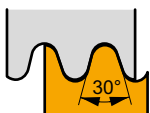

520

TN RD INT

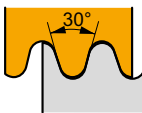

520

DİŞ AÇMA KALİTELERİ – REHBER

Kalite Tanımlama	Uygulama Alanı	Uygulama	İlerleme	Kesme hızı	Olumsuz Çalışma Koşullarına Direnç	Kaplama	Renk	Altyapı	Kesme sıvısı avantajı	Kalite açıklaması
T8010	P05 - P15	■				PVD		submicron H	+++	Bu kalite çelik, paslanmaz çelik, dökme demir ve süper alaşımlarda sürekli yüksek hassasiyetli diş tormalama işlemleri için uygundur. Operasyonel güvenilirlik ve mükemmel aşınma direnci sunar
	M05 - M15	■								
	K10 - K20	■								
	S10 - S15	■								
T8030	P25 - P40	■				PVD		submicron H	+++	Kesinlikle en iyi çok yönlü kalitedir, her tür malzemeyi işlemek için uygundur ve hemen tüm tormalama işlemlerinde uygulanabilir. Başlıca avantajları yüksek operasyonel güvenilirlik ve mükemmel sürtünme özellikleridir; bu nedenle orta ila düşük kesme hızlarındaki uygulamalar için uygundur.
	M20 - M35	■								
	K20 - K40	■								
	N15 - N30	■								
	S15 - S25	■								
H15 - H25	■									
HF7	M10 - M20	■				X		submicron H	++	Esas olarak demir dışı metallerin işlenmesi için tasarlanmış kaplamasız kalitedir; ancak diğer işlenmiş malzemeler için de kullanılabilir (çelik hariç). Bu malzeme tormalama, frezeleme ve hatta delik işlemede kullanılabilir.
	K10 - K25	■								
	N10 - N25	■								

Alt tabaka

submicron H WC-Co bazlı altyapı, ince taneli (< 1 µm)

Kaplama

PVD Düşük sıcaklıkta fiziksel kaplama yöntemi

ISO DİŞ TORNALAMA – DIŞ ÇAP

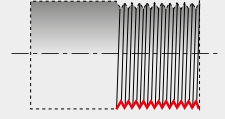

SE(RL)	
TN..	
16 22	
20×20 32×25	
522	459 – 521

SE(RL)-S	
TN..	
22	
25×25 32×25	
523	459 – 521

ISO DİŞ TORNALAMA – İÇ ÇAP

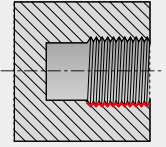

SI(RL)	
TN..	
11 16 22	
13 48	
524	459 – 521

SI(RL)-S	
TN..	
22	
39 48	
526	459 – 521

ISO DIŞ AÇMA İÇİN DEĞİŞTİRİLEBİLİR KESİCİ UÇLAR - KOD İŞARETİ

ISO	1	2	3	4	5	6	7	8
ANSI	T	N	16	E	R	175	M	P1
	1	2	3	4	5	6	7	8
	T	N	16	E	R	120	W	P1

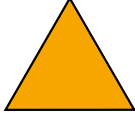
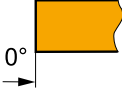
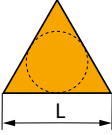
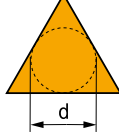
	1	2	3	3	4	4
	Uç şekli	Serbest aç	Kesici kenar uzunluğu		Diş - İç	
T					E	Diş
			L	d = IC	N	İç
			(mm) (")	(mm) (")		
			11 .433"	6,350 1/4"		
			16 .650"	9,525 3/8"		
			22 .866"	12,7 1/2"		

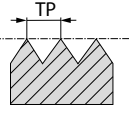
	5	5	6	7	7	
	Kesme yönü		Adım		Diş profili	
R	Sağ		Adım mm × 100	M	Metrik 60°	TR
L	Sol	s × 100		MJ	SEA MA1370	UN
N	Nötr	6	No. of threads	W	Whitworth 55° ISO 228-1982	UNJ
		Parmaktaki diş sayısı × 10		RD	Yuvarlak 30°	ACME
				BSPT	ISO 228/1 35 21 1959 ISO 7/1	STACME
				NPT	ANSI B1.1-1983	API RD

	8	8
	Talaş kırıcısı işareti	
P1	Preslenmiş	
AL	Demir içermeyenler için	

ISO KODU İŞARETİ – TAKIMLAR DIŞ AÇMA

ISO	1	2	3	-	4	5	6	7	-	8
	S	E	R		S	2525	M	16		
ANSI	1	2	3	-	4	5	6	7	-	8
	S	E	R		S	16	D	16		

1		2		3		4	
Sıkma tipi		Dış Çap/Delik İç		Direction of cut		Type of construction	
C		E	Dış çap	R	Sağ	Dış çap	Normal
						Delik içi	
P		I	Delik içi	L	Sol	Dış çap	Özel
						Delik içi	
M							
S							

5		6		7	
Boyutlar (mm)		Şaft boyu (mm)		Kesici kenar uzunluğu	
Dış çap tornalama	2525	25 x 25 mm		d = IC	T
İç çap tornalama	1416	Takım malzemesi – 14 mm Kesme kenar yüksekliği Ø – 16 mm		(mm)	(")
				6.350	1/4"
				9.525	3/8"
				12.700	1/2"

5		6		8				
Tool dimensions (")		Şaft boyu (")		Helis açısı λ				
	B (")	H (")		LF (")	0	Helis açısı λ = 0°		
	10	5/8"					C	5.000"
	12	3/4"					D	6.000"
	16	1"					E	7.000"
	85	1"					F	8.000"
	86	1"					K	5.000"
	DCON (")			LF (")	1	Helis açısı λ = 1°		
	08	.500"					M	6.000"
	10	.625"					P	6.250"
	12	.750"					Q	7.250"
	16	1.000"					R	8.000"
	20	1.250"					S	10.000"
24	1.500"	T	12.000"					
			U	14.000"	2	Helis açısı λ = 2°		

NEW**TN M EXT****PRAMET**

	IC (mm)	L (mm)	S (mm)
16	9.525	16.50	3.47
22	12.700	22.00	4.71

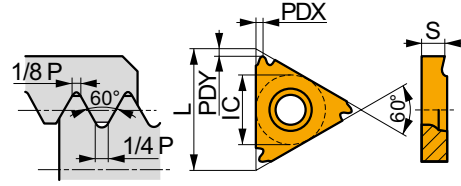

Kesme hızı (vc) için uygunluk ve başlangıç değerleri. Daha ileri hesaplamalar için İşleme Hesaplayıcısı uygulamasına başvurun.

Product	RE (mm)	P vc (m/min)	M vc (m/min)	K vc (m/min)	N vc (m/min)	S vc (m/min)	H vc (m/min)	TP (mm)	TPI	PDX (mm)	PDY (mm)

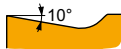

TN M ER dış, sağ kesme yönlü, ISO Metrik dişler için, darbesiz kesim.

TN 16ER050M	T8010	-	■	175	☑	105	■	165	-	☑	40	-	0.50	-	0.8	0.8	
	T8030	-	■	160	■	95	■	150	☑	480	☑	40	-	0.50	-	0.8	0.8
TN 16ER075M	T8010	-	■	175	☑	105	■	165	-	☑	40	-	0.75	-	0.8	0.8	
	T8030	-	■	160	■	95	■	150	☑	480	☑	40	-	0.75	-	0.8	0.8
TN 16ER080M	T8010	-	■	175	☑	105	■	165	-	☑	40	-	0.80	-	0.6	0.8	
	T8030	-	■	160	■	95	■	150	☑	480	☑	40	-	0.80	-	0.6	0.8
TN 16ER100M	T8010	-	■	175	☑	105	■	165	-	☑	40	-	1.00	-	0.8	0.8	
	T8030	-	■	160	■	95	■	150	☑	480	☑	40	-	1.00	-	0.8	0.8
TN 16ER125M	T8010	-	■	175	☑	105	■	165	-	☑	40	-	1.25	-	0.8	0.8	
	T8030	-	■	160	■	95	■	150	☑	480	☑	40	-	1.25	-	0.8	0.8
TN 16ER150M	T8010	-	■	175	☑	105	■	165	-	☑	40	-	1.50	-	0.8	0.8	
	T8030	-	■	160	■	95	■	150	☑	480	☑	40	-	1.50	-	0.8	0.8
TN 16ER175M	T8010	-	■	175	☑	105	■	165	-	☑	40	-	1.75	-	1.5	1.2	
	T8030	-	■	160	■	95	■	150	☑	480	☑	40	-	1.75	-	1.5	1.2
TN 16ER200M	T8010	-	■	175	☑	105	■	165	-	☑	40	-	2.00	-	1.5	1.2	
	T8030	-	■	160	■	95	■	150	☑	480	☑	40	-	2.00	-	1.5	1.2
TN 16ER250M	T8010	-	■	175	☑	105	■	165	-	☑	40	-	2.50	-	1.5	1.2	
	T8030	-	■	160	■	95	■	150	☑	480	☑	40	-	2.50	-	1.5	1.2
TN 16ER300M	T8010	-	■	175	☑	105	■	165	-	☑	40	-	3.00	-	1.5	1.2	
	T8030	-	■	160	■	95	■	150	☑	480	☑	40	-	3.00	-	1.5	1.2
TN 16ER350M	T8030 ¹⁾	-	■	160	■	95	■	150	☑	480	☑	40	-	3.50	-	1.7	1.2
TN 22ER350M	T8010	-	■	175	☑	105	■	165	-	☑	40	-	3.50	-	2.5	1.8	
	T8030	-	■	160	■	95	■	150	☑	480	☑	40	-	3.50	-	2.5	1.8
TN 22ER400M	T8010	-	■	175	☑	105	■	165	-	☑	40	-	4.00	-	2.5	1.8	
	T8030	-	■	160	■	95	■	150	☑	480	☑	40	-	4.00	-	2.5	1.8
TN 22ER450M	T8010	-	■	175	☑	105	■	165	-	☑	40	-	4.50	-	2.5	1.8	
	T8030	-	■	160	■	95	■	150	☑	480	☑	40	-	4.50	-	2.5	1.8
TN 22ER500M	T8010	-	■	175	☑	105	■	165	-	☑	40	-	5.00	-	2.5	1.8	
	T8030	-	■	160	■	95	■	150	☑	480	☑	40	-	5.00	-	2.5	1.8



TN M EL dış, sol kesme yönlü, ISO Metrik dişler için, darbesiz kesim.

TN 16EL050M	T8030	-	■	160	■	95	■	150	☑	480	☑	40	-	0.50	-	0.8	0.8
TN 16EL075M	T8030	-	■	160	■	95	■	150	☑	480	☑	40	-	0.75	-	0.8	0.8
TN 16EL080M	T8030	-	■	160	■	95	■	150	☑	480	☑	40	-	0.80	-	0.6	0.8
TN 16EL100M	T8010	-	■	175	☑	105	■	165	-	☑	40	-	1.00	-	0.8	0.8	
	T8030	-	■	160	■	95	■	150	☑	480	☑	40	-	1.00	-	0.8	0.8
TN 16EL125M	T8010	-	■	175	☑	105	■	165	-	☑	40	-	1.25	-	0.8	0.8	
	T8030	-	■	160	■	95	■	150	☑	480	☑	40	-	1.25	-	0.8	0.8

Kesme hızı (vc) için uygunluk ve başlangıç değerleri. Daha ileri hesaplamalar için İşleme Hesaplayıcısı uygulamasına başvurun.

Product	RE (mm)	P	M	K	N	S	H	TP	TPI	PDX	PDY

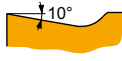

TN M-EL dış, sol kesme yönlü, ISO Metrik dişler için, darbesiz kesim.

TN 16EL150M	T8010	-	■	175	▣	105	■	165	▣	40	▣	-	1.50	-	0.8	0.8	
	T8030	-	■	160	■	95	■	150	▣	480	▣	40	-	1.50	-	0.8	0.8
TN 16EL175M	T8010	-	■	175	▣	105	■	165	-	40	▣	-	1.75	-	1.5	1.2	
	T8030	-	■	160	▣	95	■	150	▣	480	▣	40	-	1.75	-	1.5	1.2
TN 16EL200M	T8010	-	■	175	▣	105	■	165	-	40	▣	-	2.00	-	1.5	1.2	
	T8030	-	■	160	■	95	■	150	▣	480	▣	40	-	2.00	-	1.5	1.2
TN 16EL250M	T8010	-	■	175	▣	105	■	165	-	40	▣	-	2.50	-	1.5	1.2	
	T8030	-	■	160	■	95	■	150	▣	480	▣	40	-	2.50	-	1.5	1.2
TN 16EL300M	T8010	-	■	175	▣	105	■	165	-	40	▣	-	3.00	-	1.5	1.2	
	T8030	-	■	160	■	95	■	150	▣	480	▣	40	-	3.00	-	1.5	1.2
TN 16EL350M	T8030 ¹⁾	-	■	160	■	95	■	150	▣	480	▣	40	-	3.50	-	1.7	1.2
TN 22EL350M	T8030	-	■	160	■	95	■	150	▣	480	▣	40	-	3.50	-	2.5	1.8
TN 22EL400M	T8030	-	■	160	■	95	■	150	▣	480	▣	40	-	4.00	-	2.5	1.8
TN 22EL450M	T8030	-	■	160	■	95	■	150	▣	480	▣	40	-	4.50	-	2.5	1.8
TN 22EL500M	T8030	-	■	160	■	95	■	150	▣	480	▣	40	-	5.00	-	2.5	1.8

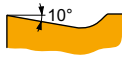

TN M-P1 ER preslenmiş dış, sağ kesme yönlü, ISO Metrik dişler için, darbesiz kesim.

TN 16ER100M-P1	T8030	-	■	160	■	95	■	150	▣	480	▣	40	-	1.00	-	0.8	0.8
TN 16ER125M-P1	T8030	-	■	160	■	95	■	150	▣	480	▣	40	-	1.25	-	0.8	0.8
TN 16ER150M-P1	T8030	-	■	160	■	95	■	150	▣	480	▣	40	-	1.50	-	0.8	0.8
TN 16ER175M-P1	T8030	-	■	160	■	95	■	150	▣	480	▣	40	-	1.75	-	1.5	1.2
TN 16ER200M-P1	T8030	-	■	160	■	95	■	150	▣	480	▣	40	-	2.00	-	1.5	1.2
TN 16ER250M-P1	T8030	-	■	160	■	95	■	150	▣	480	▣	40	-	2.50	-	1.5	1.2
TN 16ER300M-P1	T8030	-	■	160	■	95	■	150	▣	480	▣	40	-	3.00	-	1.5	1.2

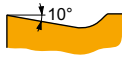

TN M-AL ER dış, sağ kesme yönlü, ISO Metrik dişler için, darbesiz kesim.

TN 16ER050M-AL	HF7	-	■	-	▣	95	■	-	▣	480	-	-	0.50	-	0.8	0.8
TN 16ER075M-AL	HF7	-	■	-	▣	95	■	-	▣	480	-	-	0.75	-	0.8	0.8
TN 16ER080M-AL	HF7	-	■	-	▣	95	■	-	▣	480	-	-	0.80	-	0.6	0.8
TN 16ER100M-AL	HF7	-	■	-	▣	95	■	-	▣	480	-	-	1.00	-	0.8	0.8
TN 16ER125M-AL	HF7	-	■	-	▣	95	■	-	▣	480	-	-	1.25	-	0.8	0.8
TN 16ER150M-AL	HF7	-	■	-	▣	95	■	-	▣	480	-	-	1.50	-	0.8	0.8
TN 16ER175M-AL	HF7	-	■	-	▣	95	■	-	▣	480	-	-	1.75	-	1.5	1.2
TN 16ER200M-AL	HF7	-	■	-	▣	95	■	-	▣	480	-	-	2.00	-	1.5	1.2
TN 16ER250M-AL	HF7	-	■	-	▣	95	■	-	▣	480	-	-	2.50	-	1.5	1.2
TN 16ER300M-AL	HF7	-	■	-	▣	95	■	-	▣	480	-	-	3.00	-	1.5	1.2

¹⁾ Toolholders have to be modified.

NEW**TN M INT****PRAMET**

	IC (mm)	L (mm)	S (mm)
11	6.350	11.00	3.00
16	9.525	16.50	3.47
22	12.700	22.00	4.71

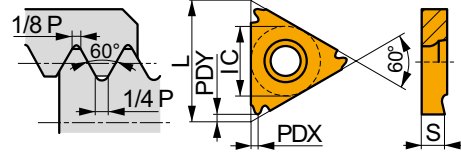

Kesme hızı (vc) için uygunluk ve başlangıç değerleri. Daha ileri hesaplamalar için İşleme Hesaplayıcısı uygulamasına başvurun.

Product	RE (mm)	P	M	K	N	S	H	TP (mm)	TPI	PDX (mm)	PDY (mm)
		vc (m/min)	vc (m/min)	vc (m/min)	vc (m/min)	vc (m/min)	vc (m/min)				

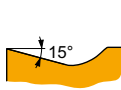
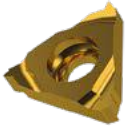

TN M NR iç, sağ kesme yönlü, ISO Metrik dişler için, darbesiz kesim.

TN 11NR050M	T8010	-	■	175	☑	105	■	165	-	☑	40	-	0.50	-	0.8	0.8	
	T8030	-	■	160	■	95	■	150	☑	480	☑	40	-	0.50	-	0.8	0.8
TN 11NR075M	T8010	-	■	175	☑	105	■	165	-	☑	40	-	0.75	-	0.8	0.8	
	T8030	-	■	160	■	95	■	150	☑	480	☑	40	-	0.75	-	0.8	0.8
TN 11NR100M	T8010	-	■	175	☑	105	■	165	-	☑	40	-	1.00	-	0.8	0.8	
	T8030	-	■	160	■	95	■	150	☑	480	☑	40	-	1.00	-	0.8	0.8
TN 11NR125M	T8010	-	■	175	☑	105	■	165	-	☑	40	-	1.25	-	0.8	0.8	
	T8030	-	■	160	■	95	■	150	☑	480	☑	40	-	1.25	-	0.8	0.8
TN 11NR150M	T8010	-	■	175	☑	105	■	165	-	☑	40	-	1.50	-	0.8	0.8	
	T8030	-	■	160	■	95	■	150	☑	480	☑	40	-	1.50	-	0.8	0.8
TN 11NR200M	T8010	-	■	175	☑	105	■	165	-	☑	40	-	2.00	-	0.9	0.8	
	T8030	-	■	160	■	95	■	150	☑	480	☑	40	-	2.00	-	0.9	0.8
TN 16NR050M	T8010	-	■	175	☑	105	■	165	-	☑	40	-	0.50	-	0.8	0.8	
	T8030	-	■	160	■	95	■	150	☑	480	☑	40	-	0.50	-	0.8	0.8
TN 16NR075M	T8010	-	■	175	☑	105	■	165	-	☑	40	-	0.75	-	0.8	0.8	
	T8030	-	■	160	■	95	■	150	☑	480	☑	40	-	0.75	-	0.8	0.8
TN 16NR100M	T8010	-	■	175	☑	105	■	165	-	☑	40	-	1.00	-	0.8	0.8	
	T8030	-	■	160	■	95	■	150	☑	480	☑	40	-	1.00	-	0.8	0.8
TN 16NR125M	T8010	-	■	175	☑	105	■	165	-	☑	40	-	1.25	-	0.8	0.8	
	T8030	-	■	160	■	95	■	150	☑	480	☑	40	-	1.25	-	0.8	0.8
TN 16NR150M	T8010	-	■	175	☑	105	■	165	-	☑	40	-	1.50	-	0.8	0.8	
	T8030	-	■	160	■	95	■	150	☑	480	☑	40	-	1.50	-	0.8	0.8
TN 16NR175M	T8010	-	■	175	☑	105	■	165	-	☑	40	-	1.75	-	1.5	1.2	
	T8030	-	■	160	■	95	■	150	☑	480	☑	40	-	1.75	-	1.5	1.2
TN 16NR200M	T8010	-	■	175	☑	105	■	165	-	☑	40	-	2.00	-	1.5	1.2	
	T8030	-	■	160	■	95	■	150	☑	480	☑	40	-	2.00	-	1.5	1.2
TN 16NR250M	T8010	-	■	175	☑	105	■	165	-	☑	40	-	2.50	-	1.5	1.2	
	T8030	-	■	160	■	95	■	150	☑	480	☑	40	-	2.50	-	1.5	1.2
TN 16NR300M	T8010	-	■	175	☑	105	■	165	-	☑	40	-	3.00	-	1.5	1.2	
	T8030	-	■	160	■	95	■	150	☑	480	☑	40	-	3.00	-	1.5	1.2
TN 16NR350M	T8030 ¹⁾	-	■	160	■	95	■	150	☑	480	☑	40	-	3.50	-	1.6	1.2
TN 22NR350M	T8010	-	■	175	☑	105	■	165	-	☑	40	-	3.50	-	2.5	1.8	
	T8030	-	■	160	■	95	■	150	☑	480	☑	40	-	3.50	-	2.5	1.8
TN 22NR400M	T8010	-	■	175	☑	105	■	165	-	☑	40	-	4.00	-	2.5	1.8	
	T8030	-	■	160	■	95	■	150	☑	480	☑	40	-	4.00	-	2.5	1.8
TN 22NR450M	T8010	-	■	175	☑	105	■	165	-	☑	40	-	4.50	-	2.5	1.8	
	T8030	-	■	160	■	95	■	150	☑	480	☑	40	-	4.50	-	2.5	1.8
TN 22NR500M	T8010	-	■	175	☑	105	■	165	-	☑	40	-	5.00	-	2.5	1.8	
	T8030	-	■	160	■	95	■	150	☑	480	☑	40	-	5.00	-	2.5	1.8

Kesme hızı (vc) için uygunluk ve başlangıç değerleri. Daha ileri hesaplamalar için İşleme Hesaplayıcısı uygulamasına başvurun.

Product	RE (mm)	P	M	K	N	S	H	TP	TPI	PDX	PDY

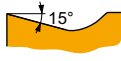

TN M NL iç, sol kesme yönlü, ISO Metrik dişler için, darbesiz kesim.

TN 11NL050M	T8030	–	■	160	■	95	■	150	▣	480	▣	40	–	0.50	–	0.8	0.8
TN 11NL075M	T8030	–	■	160	■	95	■	150	▣	480	▣	40	–	0.75	–	0.8	0.8
TN 11NL100M	T8030	–	■	160	■	95	■	150	▣	480	▣	40	–	1.00	–	0.8	0.8
TN 11NL125M	T8030	–	■	160	■	95	■	150	▣	480	▣	40	–	1.25	–	0.8	0.8
TN 11NL150M	T8010	–	■	175	▣	105	■	165	–	–	▣	40	–	1.50	–	0.8	0.8
	T8030	–	■	160	■	95	■	150	▣	480	▣	40	–	1.50	–	0.8	0.8
TN 11NL200M	T8010	–	■	175	▣	105	■	165	–	–	▣	40	–	2.00	–	0.9	0.8
	T8030	–	■	160	■	95	■	150	▣	480	▣	40	–	2.00	–	0.9	0.8
TN 16NL050M	T8030	–	■	160	■	95	■	150	▣	480	▣	40	–	0.50	–	0.8	0.8
TN 16NL075M	T8030	–	■	160	■	95	■	150	▣	480	▣	40	–	0.75	–	0.8	0.8
TN 16NL100M	T8010	–	■	175	▣	105	■	165	–	–	▣	40	–	1.00	–	0.8	0.8
	T8030	–	■	160	■	95	■	150	▣	480	▣	40	–	1.00	–	0.8	0.8
TN 16NL125M	T8010	–	■	175	▣	105	■	165	–	–	▣	40	–	1.25	–	0.8	0.8
	T8030	–	■	160	■	95	■	150	▣	480	▣	40	–	1.25	–	0.8	0.8
TN 16NL150M	T8010	–	■	175	▣	105	■	165	–	–	▣	40	–	1.50	–	0.8	0.8
	T8030	–	■	160	■	95	■	150	▣	480	▣	40	–	1.50	–	0.8	0.8
TN 16NL175M	T8010	–	■	175	▣	105	■	165	–	–	▣	40	–	1.75	–	1.5	1.2
	T8030	–	■	160	■	95	■	150	▣	480	▣	40	–	1.75	–	1.5	1.2
TN 16NL200M	T8010	–	■	175	▣	105	■	165	–	–	▣	40	–	2.00	–	1.5	1.2
	T8030	–	■	160	■	95	■	150	▣	480	▣	40	–	2.00	–	1.5	1.2
TN 16NL250M	T8010	–	■	175	▣	105	■	165	–	–	▣	40	–	2.50	–	1.5	1.2
	T8030	–	■	160	■	95	■	150	▣	480	▣	40	–	2.50	–	1.5	1.2
TN 16NL300M	T8010	–	■	175	▣	105	■	165	–	–	▣	40	–	3.00	–	1.5	1.2
	T8030	–	■	160	■	95	■	150	▣	480	▣	40	–	3.00	–	1.5	1.2
TN 16NL350M	T8030 ¹⁾	–	■	160	■	95	■	150	▣	480	▣	40	–	3.50	–	1.6	1.2
TN 22NL350M	T8030	–	■	160	■	95	■	150	▣	480	▣	40	–	3.50	–	2.5	1.8
TN 22NL400M	T8030	–	■	160	■	95	■	150	▣	480	▣	40	–	4.00	–	2.5	1.8
TN 22NL500M	T8030	–	■	160	■	95	■	150	▣	480	▣	40	–	5.00	–	2.5	1.8

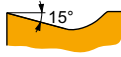

TN M-P1 NR preslenmiş iç, sağ kesme yönlü, ISO Metrik dişler için, darbesiz kesim.

TN 11NR100M-P1	T8030	–	■	160	■	95	■	150	▣	480	▣	40	–	1.00	–	0.8	0.8
TN 11NR150M-P1	T8030	–	■	160	■	95	■	150	▣	480	▣	40	–	1.50	–	0.8	0.8
TN 16NR100M-P1	T8030	–	■	160	■	95	■	150	▣	480	▣	40	–	1.00	–	0.8	0.8
TN 16NR150M-P1	T8030	–	■	160	■	95	■	150	▣	480	▣	40	–	1.50	–	0.8	0.8
TN 16NR200M-P1	T8030	–	■	160	■	95	■	150	▣	480	▣	40	–	2.00	–	1.5	1.2
TN 16NR250M-P1	T8030	–	■	160	■	95	■	150	▣	480	▣	40	–	2.50	–	1.5	1.2
TN 16NR300M-P1	T8030	–	■	160	■	95	■	150	▣	480	▣	40	–	3.00	–	1.5	1.2



TN M-AL NR iç, sağ kesme yönlü, ISO Metrik dişler için, darbesiz kesim.

TN 16NR050M-AL	HF7	–	■	–	▣	95	■	–	■	480	–	–	–	0.50	–	0.8	0.8
TN 16NR075M-AL	HF7	–	■	–	▣	95	■	–	■	480	–	–	–	0.75	–	0.8	0.8
TN 16NR100M-AL	HF7	–	■	–	▣	95	■	–	■	480	–	–	–	1.00	–	0.8	0.8
TN 16NR125M-AL	HF7	–	■	–	▣	95	■	–	■	480	–	–	–	1.25	–	0.8	0.8
TN 16NR150M-AL	HF7	–	■	–	▣	95	■	–	■	480	–	–	–	1.50	–	0.8	0.8
TN 16NR175M-AL	HF7	–	■	–	▣	95	■	–	■	480	–	–	–	1.75	–	1.5	1.2
TN 16NR200M-AL	HF7	–	■	–	▣	95	■	–	■	480	–	–	–	2.00	–	1.5	1.2
TN 16NR250M-AL	HF7	–	■	–	▣	95	■	–	■	480	–	–	–	2.50	–	1.5	1.2
TN 16NR300M-AL	HF7	–	■	–	▣	95	■	–	■	480	–	–	–	3.00	–	1.5	1.2

¹⁾ Toolholders have to be modified.

NEW**TN MJ EXT****PRAMET**

	IC (mm)	L (mm)	S (mm)
16	9.525	16.50	3.47

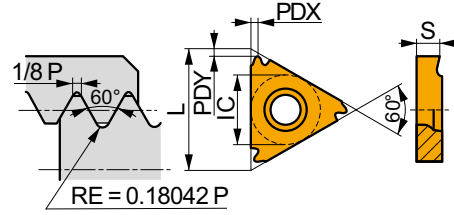

Kesme hızı (vc) için uygunluk ve başlangıç değerleri. Daha ileri hesaplamalar için İşleme Hesaplayıcısı uygulamasına başvurun.

Product	RE (mm)	P vc (m/min)	M vc (m/min)	K vc (m/min)	N vc (m/min)	S vc (m/min)	H vc (m/min)	TP (mm)	TPI	PDX (mm)	PDY (mm)



TN MJ ER dış, sağ kesme yönlü, ISO Metrik "J formu" dişler için, darbesiz kesim.

TN 16ER100MJ	T8030	-	■	160	■	95	■	150	■	480	■	40	-	1.00	-	0.8	0.8
TN 16ER150MJ	T8030	-	■	160	■	95	■	150	■	480	■	40	-	1.50	-	0.8	0.8

TN 60° PP EXT**PRAMET**

	IC (mm)	L (mm)	S (mm)
16	9.525	16.50	3.47
22	12.700	22.00	4.71

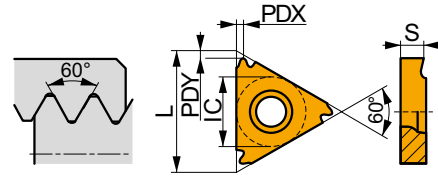

Kesme hızı (vc) için uygunluk ve başlangıç değerleri. Daha ileri hesaplamalar için İşleme Hesaplayıcısı uygulamasına başvurun.

Product	RE (mm)	P vc (m/min)	M vc (m/min)	K vc (m/min)	N vc (m/min)	S vc (m/min)	H vc (m/min)	TPN (mm)	TPX (mm)	TPIN	TPIX	PDX (mm)	PDY (mm)

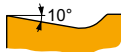

TN M60 PP ER dış, sağ kesme yönlü, Metrik ve Birleşik dişler için, darbesiz kesim.

TN 16ERA60	T8010	-	■	175	■	105	■	165	■	-	■	40	-	0.50	1.50	16	48	0.8	0.6
	T8030	-	■	160	■	95	■	150	■	480	■	40	-	0.50	1.50	16	48	0.8	0.6
TN 16ERAG60	T8010	-	■	175	■	105	■	165	■	-	■	40	-	0.50	3.00	8	48	1.5	1.1
	T8030	-	■	160	■	95	■	150	■	480	■	40	-	0.50	3.00	8	48	1.5	1.1
TN 16ERG60	T8010	-	■	175	■	105	■	165	■	-	■	40	-	1.75	3.00	8	14	1.5	1.1
	T8030	-	■	160	■	95	■	150	■	480	■	40	-	1.75	3.00	8	14	1.5	1.1
TN 22ERN60	T8010	-	■	175	■	105	■	165	■	-	■	40	-	3.50	5.00	5	7	2.5	1.8
	T8030	-	■	160	■	95	■	150	■	480	■	40	-	3.50	5.00	5	7	2.5	1.8

Kesme hızı (vc) için uygunluk ve başlangıç değerleri. Daha ileri hesaplamalar için İşleme Hesaplayıcısı uygulamasına başvurun.

Product	RE (mm)	P vc (m/min)	M vc (m/min)	K vc (m/min)	N vc (m/min)	S vc (m/min)	H vc (m/min)	TPN (mm)	TPX (mm)	TPIN	TPIX	PDX (mm)	PDY (mm)

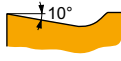

TN M60 PP EL dış, sol kesme yönlü, Metrik ve Birleşik dişler için, darbesiz kesim.

TN 16ELA60	T8030	–	■	160	■	95	■	150	■	480	■	40	–	0.50	1.50	16	48	0.8	0.6
TN 16ELAG60	T8010	–	■	175	■	105	■	165	■	–	■	40	–	0.50	3.00	8	48	1.5	1.1
	T8030	–	■	160	■	95	■	150	■	480	■	40	–	0.50	3.00	8	48	1.5	1.1
TN 16ELG60	T8030	–	■	160	■	95	■	150	■	480	■	40	–	1.75	3.00	8	14	1.5	1.1
TN 22ELN60	T8030	–	■	160	■	95	■	150	■	480	■	40	–	3.50	5.00	5	7	2.5	1.8

TN 60° PP INT

PRAMET

	IC (mm)	L (mm)	S (mm)
11	6.350	11.00	3.00
16	9.525	16.50	3.47
22	12.700	22.00	4.71

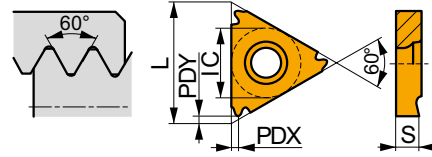

Kesme hızı (vc) için uygunluk ve başlangıç değerleri. Daha ileri hesaplamalar için İşleme Hesaplayıcısı uygulamasına başvurun.

Product	RE (mm)	P vc (m/min)	M vc (m/min)	K vc (m/min)	N vc (m/min)	S vc (m/min)	H vc (m/min)	TPN (mm)	TPX (mm)	TPIN	TPIX	PDX (mm)	PDY (mm)

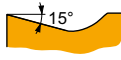

TN M60 PP NR iç, sağ kesme yönlü, Metrik ve Birleşik dişler için, darbesiz kesim.

TN 11NRA60	T8010	–	■	175	■	105	■	165	■	–	■	40	–	0.50	1.50	16	48	0.8	0.7
	T8030	–	■	160	■	95	■	150	■	480	■	40	–	0.50	1.50	16	48	0.8	0.7
TN 16NRA60	T8010	–	■	175	■	105	■	165	■	–	■	40	–	0.50	1.50	16	48	0.8	0.7
	T8030	–	■	160	■	95	■	150	■	480	■	40	–	0.50	1.50	16	48	0.8	0.7
TN 16NRAG60	T8010	–	■	175	■	105	■	165	■	–	■	40	–	0.50	3.00	8	48	1.5	1.1
	T8030	–	■	160	■	95	■	150	■	480	■	40	–	0.50	3.00	8	48	1.5	1.1
TN 16NRG60	T8010	–	■	175	■	105	■	165	■	–	■	40	–	1.75	3.00	8	14	1.5	1.1
	T8030	–	■	160	■	95	■	150	■	480	■	40	–	1.75	3.00	8	14	1.5	1.1
TN 22NRN60	T8010	–	■	175	■	105	■	165	■	–	■	40	–	3.50	5.00	5	7	2.5	1.8
	T8030	–	■	160	■	95	■	150	■	480	■	40	–	3.50	5.00	5	7	2.5	1.8

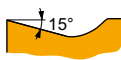

TN M60 PP NL iç, sol kesme yönlü, Metrik ve Birleşik dişler için, darbesiz kesim.

TN 11NLA60	T8030	–	■	160	■	95	■	150	■	480	■	40	–	0.50	1.50	16	48	0.8	0.7
TN 16NLA60	T8030	–	■	160	■	95	■	150	■	480	■	40	–	0.50	1.50	16	48	0.8	0.7
TN 16NLAG60	T8010	–	■	175	■	105	■	165	■	–	■	40	–	0.50	3.00	8	48	1.5	1.1
	T8030	–	■	160	■	95	■	150	■	480	■	40	–	0.50	3.00	8	48	1.5	1.1
TN 16NLG60	T8030	–	■	160	■	95	■	150	■	480	■	40	–	1.75	3.00	8	14	1.5	1.1
TN 22NLN60	T8030	–	■	160	■	95	■	150	■	480	■	40	–	3.50	5.00	5	7	2.5	1.8

TN 60°-S PP EXT

PRAMET

	IC (mm)	L (mm)	S (mm)
22	12.700	22.00	4.60

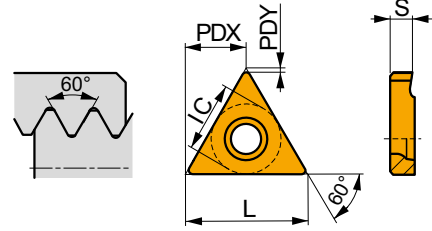

Kesme hızı (vc) için uygunluk ve başlangıç değerleri. Daha ileri hesaplamalar için İşleme Hesaplayıcısı uygulamasına başvurun.

Product	RE (mm)	P	M	K	N	S	H	TPN (mm)	TPX (mm)	TPIN (mm)	TPIX (mm)	PDX (mm)	PDY (mm)
		vc (m/min)	vc (m/min)	vc (m/min)	vc (m/min)	vc (m/min)	vc (m/min)						

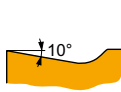

TN M60-S PP EN iç, sağ ve sol kesme yönlü, Metrik ve Birleşik dişler için, darbesiz kesim.

TN 22EN350-500M	T8030	-	■	160	■	95	■	150	■	480	■	40	-	3.50	5.00	5	7	11.0	0.5
TN 22EN550-800M	T8030	-	■	160	■	95	■	150	■	480	■	40	-	5.50	8.00	3	4.5	11.0	0.8

TN 60°-S PP INT

PRAMET

	IC (mm)	L (mm)	S (mm)
22	12.700	22.00	4.60

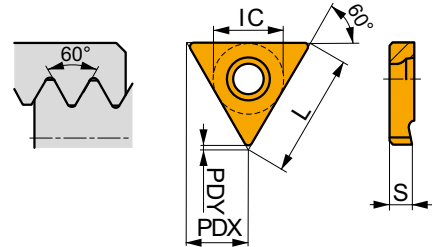

Kesme hızı (vc) için uygunluk ve başlangıç değerleri. Daha ileri hesaplamalar için İşleme Hesaplayıcısı uygulamasına başvurun.

Product	RE (mm)	P	M	K	N	S	H	TPN (mm)	TPX (mm)	TPIN (mm)	TPIX (mm)	PDX (mm)	PDY (mm)
		vc (m/min)	vc (m/min)	vc (m/min)	vc (m/min)	vc (m/min)	vc (m/min)						

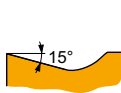

TN M60-S PP NN iç, sağ ve sol kesme yönlü, Metrik ve Birleşik dişler için, darbesiz kesim.

TN 22NN350-500M	T8030	-	■	160	■	95	■	150	■	480	■	40	-	3.50	5.00	5	7	11.0	0.2
TN 22NN550-800M	T8030	-	■	160	■	95	■	150	■	480	■	40	-	5.50	8.00	3	4.5	11.0	0.5

TN UN EXT

	IC (mm)	L (mm)	S (mm)
16	9.525	16.50	3.47
22	12.700	22.00	4.71

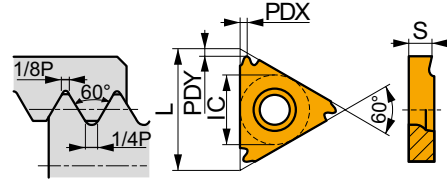

Kesme hızı (vc) için uygunluk ve başlangıç değerleri. Daha ileri hesaplamalar için İşleme Hesaplayıcısı uygulamasına başvurun.

Product	RE (mm)	P	M	K	N	S	H	TP (mm)	TPI	PDX (mm)	PDY (mm)
		vc (m/min)	vc (m/min)	vc (m/min)	vc (m/min)	vc (m/min)	vc (m/min)				

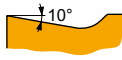
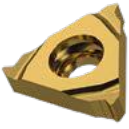

TN UN ER dış, sağ kesme yönlü, Birleşik dişler için, darbesiz kesim.

TN 16ER320UN	T8030	–	■	160	■	95	■	150	■	480	■	40	–	–	32.0	0.8	0.8
TN 16ER280UN	T8030	–	■	160	■	95	■	150	■	480	■	40	–	–	28.0	0.8	0.8
TN 16ER240UN	T8030	–	■	160	■	95	■	150	■	480	■	40	–	–	24.0	0.8	0.8
TN 16ER200UN	T8010	–	■	175	■	105	■	165	■	–	■	40	–	–	20.0	0.8	0.8
	T8030	–	■	160	■	95	■	150	■	480	■	40	–	–	20.0	0.8	0.8
TN 16ER180UN	T8030	–	■	160	■	95	■	150	■	480	■	40	–	–	18.0	0.8	0.8
TN 16ER160UN	T8030	–	■	160	■	95	■	150	■	480	■	40	–	–	16.0	0.8	0.8
TN 16ER140UN	T8030	–	■	160	■	95	■	150	■	480	■	40	–	–	14.0	1.5	1.2
TN 16ER130UN	T8030	–	■	160	■	95	■	150	■	480	■	40	–	–	13.0	1.5	1.2
TN 16ER120UN	T8030	–	■	160	■	95	■	150	■	480	■	40	–	–	12.0	1.5	1.2
TN 16ER115UN	T8030	–	■	160	■	95	■	150	■	480	■	40	–	–	11.5	1.5	1.2
TN 16ER110UN	T8030	–	■	160	■	95	■	150	■	480	■	40	–	–	11.0	1.5	1.2
TN 16ER100UN	T8030	–	■	160	■	95	■	150	■	480	■	40	–	–	10.0	1.5	1.2
TN 16ER090UN	T8030	–	■	160	■	95	■	150	■	480	■	40	–	–	9.0	1.5	1.2
TN 16ER080UN	T8030	–	■	160	■	95	■	150	■	480	■	40	–	–	8.0	1.5	1.2
TN 22ER070UN	T8030	–	■	160	■	95	■	150	■	480	■	40	–	–	7.0	2.5	1.8
TN 22ER060UN	T8030	–	■	160	■	95	■	150	■	480	■	40	–	–	6.0	2.5	1.8
TN 22ER050UN	T8030	–	■	160	■	95	■	150	■	480	■	40	–	–	5.0	2.5	1.8

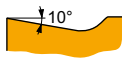

TN UN EL dış, sol kesme yönlü, Birleşik dişler için, darbesiz kesim.

TN 16EL320UN	T8030	–	■	160	■	95	■	150	■	480	■	40	–	–	32.0	0.8	0.8
TN 16EL280UN	T8030	–	■	160	■	95	■	150	■	480	■	40	–	–	28.0	0.8	0.8
TN 16EL240UN	T8030	–	■	160	■	95	■	150	■	480	■	40	–	–	24.0	0.8	0.8
TN 16EL200UN	T8030	–	■	160	■	95	■	150	■	480	■	40	–	–	20.0	0.8	0.8
TN 16EL180UN	T8030	–	■	160	■	95	■	150	■	480	■	40	–	–	18.0	0.8	0.8
TN 16EL160UN	T8030	–	■	160	■	95	■	150	■	480	■	40	–	–	16.0	0.8	0.8
TN 16EL140UN	T8030	–	■	160	■	95	■	150	■	480	■	40	–	–	14.0	1.5	1.2
TN 16EL120UN	T8030	–	■	160	■	95	■	150	■	480	■	40	–	–	12.0	1.5	1.2
TN 16EL110UN	T8030	–	■	160	■	95	■	150	■	480	■	40	–	–	11.0	1.5	1.2
TN 16EL100UN	T8030	–	■	160	■	95	■	150	■	480	■	40	–	–	10.0	1.5	1.2
TN 16EL090UN	T8030	–	■	160	■	95	■	150	■	480	■	40	–	–	9.0	1.5	1.2
TN 16EL080UN	T8030	–	■	160	■	95	■	150	■	480	■	40	–	–	8.0	1.5	1.2
TN 22EL070UN	T8030	–	■	160	■	95	■	150	■	480	■	40	–	–	7.0	2.5	1.8
TN 22EL060UN	T8030	–	■	160	■	95	■	150	■	480	■	40	–	–	6.0	2.5	1.8
TN 22EL050UN	T8030	–	■	160	■	95	■	150	■	480	■	40	–	–	5.0	2.5	1.8

Kesme hızı (vc) için uygunluk ve başlangıç değerleri. Daha ileri hesaplamalar için İşleme Hesaplayıcısı uygulamasına başvurun.

Product	RE (mm)	P vc (m/min)	M vc (m/min)	K vc (m/min)	N vc (m/min)	S vc (m/min)	H vc (m/min)	TP (mm)	TPI	PDX (mm)	PDY (mm)

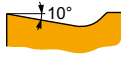

TN UN-P1 ER preslenmiş dış, sağ kesme yönlü, Birleşik dişler için, darbesiz kesim.

TN 16ER200UN-P1	T8030	-	■	160	■	95	■	150	■	480	■	40	-	-	20.0	0.8	0.8
TN 16ER180UN-P1	T8030	-	■	160	■	95	■	150	■	480	■	40	-	-	18.0	0.8	0.8
TN 16ER160UN-P1	T8030	-	■	160	■	95	■	150	■	480	■	40	-	-	16.0	0.8	0.8
TN 16ER140UN-P1	T8030	-	■	160	■	95	■	150	■	480	■	40	-	-	14.0	1.5	1.2
TN 16ER120UN-P1	T8030	-	■	160	■	95	■	150	■	480	■	40	-	-	12.0	1.5	1.2
TN 16ER080UN-P1	T8030	-	■	160	■	95	■	150	■	480	■	40	-	-	8.0	1.5	1.2

TN UN INT

PRAMET

	IC (mm)	L (mm)	S (mm)
16	9.525	16.50	3.47
22	12.700	22.00	4.71

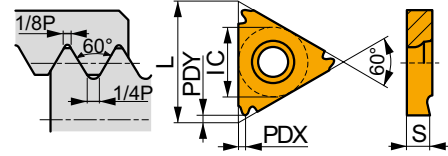

Kesme hızı (vc) için uygunluk ve başlangıç değerleri. Daha ileri hesaplamalar için İşleme Hesaplayıcısı uygulamasına başvurun.

Product	RE (mm)	P vc (m/min)	M vc (m/min)	K vc (m/min)	N vc (m/min)	S vc (m/min)	H vc (m/min)	TP (mm)	TPI	PDX (mm)	PDY (mm)

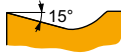
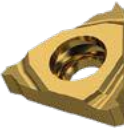

TN UN NR iç, sağ kesme yönlü, Birleşik dişler için, darbesiz kesim.

TN 16NR320UN	T8030	-	■	160	■	95	■	150	■	480	■	40	-	-	32.0	0.8	0.8
TN 16NR280UN	T8030	-	■	160	■	95	■	150	■	480	■	40	-	-	28.0	0.8	0.8
TN 16NR240UN	T8030	-	■	160	■	95	■	150	■	480	■	40	-	-	24.0	0.8	0.8
TN 16NR200UN	T8010	-	■	175	■	105	■	165	■	-	■	40	-	-	20.0	0.8	0.8
	T8030	-	■	160	■	95	■	150	■	480	■	40	-	-	20.0	0.8	0.8
TN 16NR180UN	T8030	-	■	160	■	95	■	150	■	480	■	40	-	-	18.0	0.8	0.8
TN 16NR160UN	T8030	-	■	160	■	95	■	150	■	480	■	40	-	-	16.0	0.8	0.8
TN 16NR140UN	T8030	-	■	160	■	95	■	150	■	480	■	40	-	-	14.0	1.5	1.2
TN 16NR130UN	T8030	-	■	160	■	95	■	150	■	480	■	40	-	-	13.0	1.5	1.2
TN 16NR120UN	T8010	-	■	175	■	105	■	165	■	-	■	40	-	-	12.0	1.5	1.2
	T8030	-	■	160	■	95	■	150	■	480	■	40	-	-	12.0	1.5	1.2
TN 16NR115UN	T8030	-	■	160	■	95	■	150	■	480	■	40	-	-	11.5	1.5	1.2
TN 16NR110UN	T8030	-	■	160	■	95	■	150	■	480	■	40	-	-	11.0	1.5	1.2
TN 16NR100UN	T8030	-	■	160	■	95	■	150	■	480	■	40	-	-	10.0	1.5	1.2
TN 16NR080UN	T8010	-	■	175	■	105	■	165	■	-	■	40	-	-	8.0	1.5	1.2
	T8030	-	■	160	■	95	■	150	■	480	■	40	-	-	8.0	1.5	1.2
TN 22NR070UN	T8030	-	■	160	■	95	■	150	■	480	■	40	-	-	7.0	2.5	1.8
TN 22NR060UN	T8030	-	■	160	■	95	■	150	■	480	■	40	-	-	6.0	2.5	1.8
TN 22NR050UN	T8030	-	■	160	■	95	■	150	■	480	■	40	-	-	5.0	2.5	1.8



TN UN NL iç, sol kesme yönlü, Birleşik dişler için, darbesiz kesim.

TN 16NL320UN	T8030	-	■	160	■	95	■	150	■	480	■	40	-	-	32.0	0.8	0.8
--------------	-------	---	---	-----	---	----	---	-----	---	-----	---	----	---	---	------	-----	-----

Kesme hızı (vc) için uygunluk ve başlangıç değerleri. Daha ileri hesaplamalar için İşleme Hesaplayıcısı uygulamasına başvurun.

Product	RE (mm)	P	M	K	N	S	H	TP	TPI	PDX	PDY

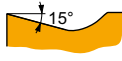

TN UN NL iç, sol kesme yönlü, Birleşik dişler için, darbesiz kesim.

TN 16NL280UN	T8030	–	■	160	■	95	■	150	▣	480	▣	40	–	–	28.0	0.8	0.8
TN 16NL240UN	T8030	–	■	160	■	95	■	150	▣	480	▣	40	–	–	24.0	0.8	0.8
TN 16NL200UN	T8030	–	■	160	■	95	■	150	▣	480	▣	40	–	–	20.0	0.8	0.8
TN 16NL180UN	T8030	–	■	160	■	95	■	150	▣	480	▣	40	–	–	18.0	0.8	0.8
TN 16NL160UN	T8030	–	■	160	■	95	■	150	▣	480	▣	40	–	–	16.0	0.8	0.8
TN 16NL140UN	T8030	–	■	160	■	95	■	150	▣	480	▣	40	–	–	14.0	1.5	1.2
TN 16NL120UN	T8030	–	■	160	■	95	■	150	▣	480	▣	40	–	–	12.0	1.5	1.2
TN 16NL110UN	T8030	–	■	160	■	95	■	150	▣	480	▣	40	–	–	11.0	1.5	1.2
TN 16NL100UN	T8030	–	■	160	■	95	■	150	▣	480	▣	40	–	–	10.0	1.5	1.2
TN 16NL080UN	T8030	–	■	160	■	95	■	150	▣	480	▣	40	–	–	8.0	1.5	1.2
TN 22NL070UN	T8030	–	■	160	■	95	■	150	▣	480	▣	40	–	–	7.0	2.5	1.8
TN 22NL060UN	T8030	–	■	160	■	95	■	150	▣	480	▣	40	–	–	6.0	2.5	1.8



TN UN-P1 NR preslenmiş iç, sağ kesme yönlü, Birleşik dişler için, darbesiz kesim.

TN 16NR200UN-P1	T8030	–	■	160	■	95	■	150	▣	480	▣	40	–	–	20.0	0.8	0.8
TN 16NR180UN-P1	T8030	–	■	160	■	95	■	150	▣	480	▣	40	–	–	18.0	0.8	0.8
TN 16NR160UN-P1	T8030	–	■	160	■	95	■	150	▣	480	▣	40	–	–	16.0	0.8	0.8
TN 16NR140UN-P1	T8030	–	■	160	■	95	■	150	▣	480	▣	40	–	–	14.0	1.5	1.2
TN 16NR120UN-P1	T8030	–	■	160	■	95	■	150	▣	480	▣	40	–	–	12.0	1.5	1.2
TN 16NR080UN-P1	T8030	–	■	160	■	95	■	150	▣	480	▣	40	–	–	8.0	1.5	1.2

NEW

TN UNJ EXT

PRAMET

	IC (mm)	L (mm)	S (mm)
16	9.525	16.50	3.47

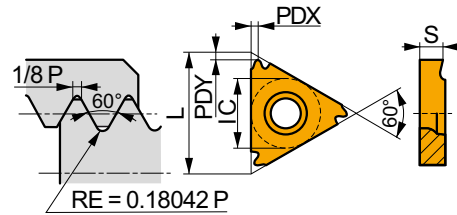

Kesme hızı (vc) için uygunluk ve başlangıç değerleri. Daha ileri hesaplamalar için İşleme Hesaplayıcısı uygulamasına başvurun.

Product	RE (mm)	P	M	K	N	S	H	TP	TPI	PDX	PDY

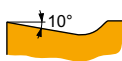

TN UNJ ER dış, sağ kesme yönlü, Birleşik dişler "J Formu" için, darbesiz kesim.

TN 16ER320UNJ	T8030	–	■	160	■	95	■	150	▣	480	▣	40	–	–	32.0	0.8	0.8
TN 16ER280UNJ	T8030	–	■	160	■	95	■	150	▣	480	▣	40	–	–	28.0	0.8	0.8
TN 16ER240UNJ	T8030	–	■	160	■	95	■	150	▣	480	▣	40	–	–	24.0	0.8	0.8
TN 16ER200UNJ	T8030	–	■	160	■	95	■	150	▣	480	▣	40	–	–	20.0	0.8	0.8
TN 16ER180UNJ	T8030	–	■	160	■	95	■	150	▣	480	▣	40	–	–	18.0	0.8	0.8
TN 16ER160UNJ	T8030	–	■	160	■	95	■	150	▣	480	▣	40	–	–	16.0	1.5	1.2
TN 16ER120UNJ	T8030	–	■	160	■	95	■	150	▣	480	▣	40	–	–	12.0	1.5	1.2

Kesme hızı (vc) için uygunluk ve başlangıç değerleri. Daha ileri hesaplamalar için İşleme Hesaplayıcısı uygulamasına başvurun.

Product	RE (mm)	P vc (m/min)	M vc (m/min)	K vc (m/min)	N vc (m/min)	S vc (m/min)	H vc (m/min)	TP (mm)	TPI	PDX (mm)	PDY (mm)

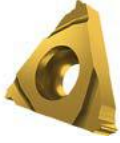

TN UNJ EL dış, sol kesme yönlü, Birleşik dişler "J Formu" için, darbesiz kesim.

TN 16EL320UNJ	T8030	-	■	160	■	95	■	150	■	480	■	40	-	-	32.0	0.8	0.8
TN 16EL280UNJ	T8030	-	■	160	■	95	■	150	■	480	■	40	-	-	28.0	0.8	0.8
TN 16EL240UNJ	T8030	-	■	160	■	95	■	150	■	480	■	40	-	-	24.0	0.8	0.8
TN 16EL200UNJ	T8030	-	■	160	■	95	■	150	■	480	■	40	-	-	20.0	0.8	0.8
TN 16EL180UNJ	T8030	-	■	160	■	95	■	150	■	480	■	40	-	-	18.0	0.8	0.8
TN 16EL160UNJ	T8030	-	■	160	■	95	■	150	■	480	■	40	-	-	16.0	1.5	1.2
TN 16EL120UNJ	T8030	-	■	160	■	95	■	150	■	480	■	40	-	-	12.0	1.5	1.2

TN W EXT



	IC (mm)	L (mm)	S (mm)
16	9.525	16.50	3.47
22	12.700	22.00	4.71

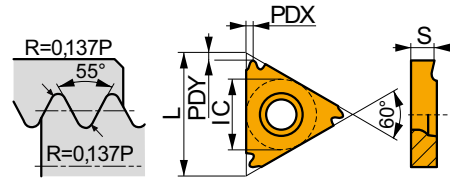

Kesme hızı (vc) için uygunluk ve başlangıç değerleri. Daha ileri hesaplamalar için İşleme Hesaplayıcısı uygulamasına başvurun.

Product	RE (mm)	P vc (m/min)	M vc (m/min)	K vc (m/min)	N vc (m/min)	S vc (m/min)	H vc (m/min)	TP (mm)	TPI	PDX (mm)	PDY (mm)



TN W ER dış, sağ kesme yönlü, Whitworth dişler için, darbesiz kesim.

TN 16ER280W	T8030	-	■	160	■	95	■	150	■	480	■	40	-	-	28.0	0.8	0.8
TN 16ER260W	T8030	-	■	160	■	95	■	150	■	480	■	40	-	-	26.0	0.8	0.8
TN 16ER240W	T8030	-	■	160	■	95	■	150	■	480	■	40	-	-	24.0	0.8	0.8
TN 16ER200W	T8030	-	■	160	■	95	■	150	■	480	■	40	-	-	20.0	0.8	0.8
TN 16ER190W	T8010	-	■	175	■	105	■	165	■	-	■	40	-	-	19.0	0.8	0.8
	T8030	-	■	160	■	95	■	150	■	480	■	40	-	-	19.0	0.8	0.8
TN 16ER180W	T8030	-	■	160	■	95	■	150	■	480	■	40	-	-	18.0	0.8	0.8
TN 16ER160W	T8030	-	■	160	■	95	■	150	■	480	■	40	-	-	16.0	0.8	0.8
TN 16ER140W	T8010	-	■	175	■	105	■	165	■	-	■	40	-	-	14.0	1.5	1.2
	T8030	-	■	160	■	95	■	150	■	480	■	40	-	-	14.0	1.5	1.2
TN 16ER120W	T8030	-	■	160	■	95	■	150	■	480	■	40	-	-	12.0	1.5	1.2
TN 16ER110W	T8010	-	■	175	■	105	■	165	■	-	■	40	-	-	11.0	1.5	1.2
	T8030	-	■	160	■	95	■	150	■	480	■	40	-	-	11.0	1.5	1.2
TN 16ER100W	T8030	-	■	160	■	95	■	150	■	480	■	40	-	-	10.0	1.5	1.2
TN 16ER090W	T8030	-	■	160	■	95	■	150	■	480	■	40	-	-	9.0	1.5	1.2
TN 16ER080W	T8030	-	■	160	■	95	■	150	■	480	■	40	-	-	8.0	1.5	1.2
TN 22ER070W	T8030	-	■	160	■	95	■	150	■	480	■	40	-	-	7.0	2.5	1.8
TN 22ER060W	T8030	-	■	160	■	95	■	150	■	480	■	40	-	-	6.0	2.5	1.8
TN 22ER050W	T8030	-	■	160	■	95	■	150	■	480	■	40	-	-	5.0	2.5	1.7

Kesme hızı (vc) için uygunluk ve başlangıç değerleri. Daha ileri hesaplamalar için İşleme Hesaplayıcısı uygulamasına başvurun.

Product	RE (mm)	P vc (m/min)	M vc (m/min)	K vc (m/min)	N vc (m/min)	S vc (m/min)	H vc (m/min)	TP (mm)	TPI	PDX (mm)	PDY (mm)

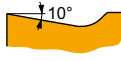
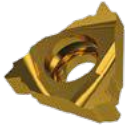

TN W EL dış, sol kesme yönlü, Whitworth dişler için, darbesiz kesim.

TN 16EL280W	T8030	–	■	160	■	95	■	150	■	480	■	40	–	–	28.0	0.8	0.8
TN 16EL260W	T8030	–	■	160	■	95	■	150	■	480	■	40	–	–	26.0	0.8	0.8
TN 16EL240W	T8030	–	■	160	■	95	■	150	■	480	■	40	–	–	24.0	0.8	0.8
TN 16EL200W	T8030	–	■	160	■	95	■	150	■	480	■	40	–	–	20.0	0.8	0.8
TN 16EL190W	T8030	–	■	160	■	95	■	150	■	480	■	40	–	–	19.0	0.8	0.8
TN 16EL160W	T8030	–	■	160	■	95	■	150	■	480	■	40	–	–	16.0	0.8	0.8
TN 16EL140W	T8030	–	■	160	■	95	■	150	■	480	■	40	–	–	14.0	1.5	1.2
TN 16EL120W	T8030	–	■	160	■	95	■	150	■	480	■	40	–	–	12.0	1.5	1.2
TN 16EL110W	T8030	–	■	160	■	95	■	150	■	480	■	40	–	–	11.0	1.5	1.2
TN 16EL100W	T8030	–	■	160	■	95	■	150	■	480	■	40	–	–	10.0	1.5	1.2
TN 16EL090W	T8030	–	■	160	■	95	■	150	■	480	■	40	–	–	9.0	1.5	1.2
TN 16EL080W	T8030	–	■	160	■	95	■	150	■	480	■	40	–	–	8.0	1.5	1.2
TN 22EL070W	T8030	–	■	160	■	95	■	150	■	480	■	40	–	–	7.0	2.5	1.8
TN 22EL060W	T8030	–	■	160	■	95	■	150	■	480	■	40	–	–	6.0	2.5	1.8
TN 22EL050W	T8030	–	■	160	■	95	■	150	■	480	■	40	–	–	5.0	2.5	1.7

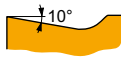

TN W-P1 ER preslenmiş dış, sağ kesme yönlü, Whitworth dişler için, darbesiz kesim.

TN 16ER190W-P1	T8030	–	■	160	■	95	■	150	■	480	■	40	–	–	19.0	0.8	0.8
TN 16ER140W-P1	T8030	–	■	160	■	95	■	150	■	480	■	40	–	–	14.0	1.5	1.2
TN 16ER110W-P1	T8030	–	■	160	■	95	■	150	■	480	■	40	–	–	11.0	1.5	1.2

TN W INT

PRAMET

	IC (mm)	L (mm)	S (mm)
11	6.350	11.00	3.00
16	9.525	16.50	3.47
22	12.700	22.00	4.71

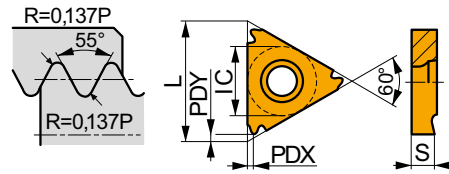

Kesme hızı (vc) için uygunluk ve başlangıç değerleri. Daha ileri hesaplamalar için İşleme Hesaplayıcısı uygulamasına başvurun.

Product	RE (mm)	P vc (m/min)	M vc (m/min)	K vc (m/min)	N vc (m/min)	S vc (m/min)	H vc (m/min)	TP (mm)	TPI	PDX (mm)	PDY (mm)

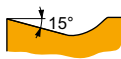
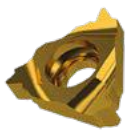

TN W NR iç, sağ kesme yönlü, Whitworth dişler için, darbesiz kesim.

TN 11NR190W	T8010	–	■	175	■	105	■	165	■	–	■	40	–	–	19.0	0.8	0.8
	T8030	–	■	160	■	95	■	150	■	480	■	40	–	–	19.0	0.8	0.8
TN 11NR140W	T8010	–	■	175	■	105	■	165	■	–	■	40	–	–	14.0	0.9	0.7
	T8030	–	■	160	■	95	■	150	■	480	■	40	–	–	14.0	0.9	0.7
TN 16NR280W	T8030	–	■	160	■	95	■	150	■	480	■	40	–	–	28.0	0.8	0.8
TN 16NR260W	T8030	–	■	160	■	95	■	150	■	480	■	40	–	–	26.0	0.8	0.8
TN 16NR240W	T8030	–	■	160	■	95	■	150	■	480	■	40	–	–	24.0	0.8	0.8
TN 16NR200W	T8030	–	■	160	■	95	■	150	■	480	■	40	–	–	20.0	0.8	0.8

Kesme hızı (vc) için uygunluk ve başlangıç değerleri. Daha ileri hesaplamalar için İşleme Hesaplayıcısı uygulamasına başvurun.

Product	RE (mm)	P	M	K	N	S	H	TP	TPI	PDX	PDY	vc	
												(m/min)	(m/min)

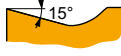
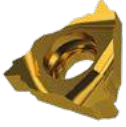

TN W NR iç, sağ kesme yönlü, Whitworth dişler için, darbesiz kesim.

TN 16NR190W	T8010	-	■	175	☑	105	■	165	-	☑	40	-	-	19.0	0.8	0.8	
	T8030	-	■	160	■	95	■	150	☑	480	☑	40	-	-	19.0	0.8	0.8
TN 16NR160W	T8030	-	■	160	■	95	■	150	☑	480	☑	40	-	-	16.0	0.8	0.8
TN 16NR140W	T8010	-	■	175	☑	105	■	165	-	☑	40	-	-	14.0	1.5	1.2	
	T8030	-	■	160	■	95	■	150	☑	480	☑	40	-	-	14.0	1.5	1.2
TN 16NR120W	T8030	-	■	160	■	95	■	150	☑	480	☑	40	-	-	12.0	1.5	1.2
TN 16NR110W	T8010	-	■	175	☑	105	■	165	-	☑	40	-	-	11.0	1.5	1.2	
	T8030	-	■	160	■	95	■	150	☑	480	☑	40	-	-	11.0	1.5	1.2
TN 16NR100W	T8030	-	■	160	■	95	■	150	☑	480	☑	40	-	-	10.0	1.5	1.2
TN 16NR090W	T8030	-	■	160	■	95	■	150	☑	480	☑	40	-	-	9.0	1.5	1.2
TN 16NR080W	T8030	-	■	160	■	95	■	150	☑	480	☑	40	-	-	8.0	1.5	1.2
TN 22NR070W	T8030	-	■	160	■	95	■	150	☑	480	☑	40	-	-	7.0	2.5	1.8
TN 22NR060W	T8030	-	■	160	■	95	■	150	☑	480	☑	40	-	-	6.0	2.5	1.8
TN 22NR050W	T8030	-	■	160	■	95	■	150	☑	480	☑	40	-	-	5.0	2.5	1.7

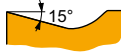

TN W NL iç, sol kesme yönlü, Whitworth dişler için, darbesiz kesim.

TN 11NL190W	T8030	-	■	160	■	95	■	150	☑	480	☑	40	-	-	19.0	0.8	0.8
TN 11NL140W	T8030	-	■	160	■	95	■	150	☑	480	☑	40	-	-	14.0	0.9	0.7
TN 16NL280W	T8030	-	■	160	■	95	■	150	☑	480	☑	40	-	-	28.0	0.8	0.8
TN 16NL260W	T8030	-	■	160	■	95	■	150	☑	480	☑	40	-	-	26.0	0.8	0.8
TN 16NL240W	T8030	-	■	160	■	95	■	150	☑	480	☑	40	-	-	24.0	0.8	0.8
TN 16NL200W	T8030	-	■	160	■	95	■	150	☑	480	☑	40	-	-	20.0	0.8	0.8
TN 16NL190W	T8030	-	■	160	■	95	■	150	☑	480	☑	40	-	-	19.0	0.8	0.8
TN 16NL160W	T8030	-	■	160	■	95	■	150	☑	480	☑	40	-	-	16.0	0.8	0.8
TN 16NL140W	T8030	-	■	160	■	95	■	150	☑	480	☑	40	-	-	14.0	1.5	1.2
TN 16NL120W	T8030	-	■	160	■	95	■	150	☑	480	☑	40	-	-	12.0	1.5	1.2
TN 16NL110W	T8030	-	■	160	■	95	■	150	☑	480	☑	40	-	-	11.0	1.5	1.2
TN 16NL100W	T8030	-	■	160	■	95	■	150	☑	480	☑	40	-	-	10.0	1.5	1.2
TN 16NL090W	T8030	-	■	160	■	95	■	150	☑	480	☑	40	-	-	9.0	1.5	1.2
TN 16NL080W	T8030	-	■	160	■	95	■	150	☑	480	☑	40	-	-	8.0	1.5	1.2
TN 22NL070W	T8030	-	■	160	■	95	■	150	☑	480	☑	40	-	-	7.0	2.5	1.8
TN 22NL060W	T8030	-	■	160	■	95	■	150	☑	480	☑	40	-	-	6.0	2.5	1.8
TN 22NL050W	T8030	-	■	160	■	95	■	150	☑	480	☑	40	-	-	5.0	2.5	1.7

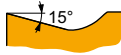

TN W-P1 NR preslenmiş iç, sol kesme yönlü, Whitworth dişler için, darbesiz kesim.

TN 11NR190W-P1	T8030	-	■	160	■	95	■	150	☑	480	☑	40	-	-	19.0	0.8	0.8
TN 11NR140W-P1	T8030	-	■	160	■	95	■	150	☑	480	☑	40	-	-	14.0	0.9	0.7
TN 16NR140W-P1	T8030	-	■	160	■	95	■	150	☑	480	☑	40	-	-	14.0	1.5	1.2
TN 16NR110W-P1	T8030	-	■	160	■	95	■	150	☑	480	☑	40	-	-	11.0	1.5	1.2

TN 55° PP EXT

	IC (mm)	L (mm)	S (mm)
16	9.525	16.50	3.47
22	12.700	22.00	4.71

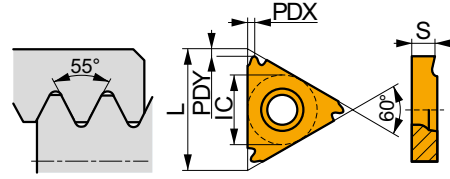

Kesme hızı (vc) için uygunluk ve başlangıç değerleri. Daha ileri hesaplamalar için İşleme Hesaplayıcısı uygulamasına başvurun.

Product	RE (mm)	P	M	K	N	S	H	TPN (mm)	TPX (mm)	TPIN (mm)	TPIX (mm)	PDX (mm)	PDY (mm)
		vc (m/min)	vc (m/min)	vc (m/min)	vc (m/min)	vc (m/min)	vc (m/min)						



TN W ER dış, sağ kesme yönlü, Whitworth dişler için, darbesiz kesim.

TN 16ERA55	T8030	–	160	95	150	480	40	–	0.50	1.50	16	48	0.8	0.6
TN 16ERAG55	T8010	–	175	105	165	–	40	–	0.50	3.00	8	48	1.5	1.1
	T8030	–	160	95	150	480	40	–	0.50	3.00	8	48	1.5	1.1
TN 16ERG55	T8030	–	160	95	150	480	40	–	1.75	3.00	8	14	1.5	1.1
TN 22ERN55	T8010	–	175	105	165	–	40	–	3.50	5.00	5	7	2.5	1.8
	T8030	–	160	95	150	480	40	–	3.50	5.00	5	7	2.5	1.8

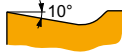

TN W55 PP EL dış, sol kesme yönlü, Whitworth dişler için, darbesiz kesim.

TN 16ELA55	T8030	–	160	95	150	480	40	–	0.50	1.50	16	48	0.8	0.6
TN 16ELAG55	T8030	–	160	95	150	480	40	–	0.50	3.00	8	48	1.5	1.1
TN 16ELG55	T8030	–	160	95	150	480	40	–	1.75	3.00	8	14	1.5	1.1
TN 22ELN55	T8030	–	160	95	150	480	40	–	3.50	5.00	5	7	2.5	1.8

TN 55° PP INT

	IC (mm)	L (mm)	S (mm)
11	6.350	11.00	3.00
16	9.525	16.50	3.47
22	12.700	22.00	4.71

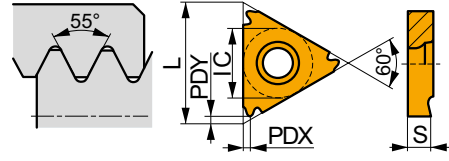

Kesme hızı (vc) için uygunluk ve başlangıç değerleri. Daha ileri hesaplamalar için İşleme Hesaplayıcısı uygulamasına başvurun.

Product	RE (mm)	P vc (m/min)	M vc (m/min)	K vc (m/min)	N vc (m/min)	S vc (m/min)	H vc (m/min)	TPN (mm)	TPX (mm)	TPIN	TPIX	PDX (mm)	PDY (mm)

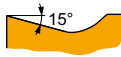

TN W NR iç, sol kesme yönlü, Whitworth dişler için, darbesiz kesim.

TN 11NRA55	T8030	-	160	95	150	480	40	-	0.50	1.50	16	48	0.8	0.6
TN 16NRA55	T8030	-	160	95	150	480	40	-	0.50	1.50	16	48	0.8	0.6
TN 16NRAG55	T8010	-	175	105	165	-	40	-	0.50	3.00	8	48	1.5	1.1
	T8030	-	160	95	150	480	40	-	0.50	3.00	8	48	1.5	1.1
TN 16NRG55	T8030	-	160	95	150	480	40	-	1.75	3.00	8	14	1.5	1.1
TN 22NRN55	T8030	-	160	95	150	480	40	-	3.50	5.00	5	7	2.5	1.8

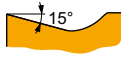

TN W NL iç, sol kesme yönlü, Whitworth dişler için, darbesiz kesim.

TN 11NLA55	T8030	-	160	95	150	480	40	-	0.50	1.50	16	48	0.8	0.6
TN 16NLA55	T8030	-	160	95	150	480	40	-	0.50	1.50	16	48	0.8	0.6
TN 16NLAG55	T8030	-	160	95	150	480	40	-	0.50	3.00	8	48	1.5	1.1
TN 16NLG55	T8030	-	160	95	150	480	40	-	1.75	3.00	8	14	1.5	1.1
TN 22NLN55	T8030	-	160	95	150	480	40	-	3.50	5.00	5	7	2.5	1.8

TN BSPT EXT

	IC (mm)	L (mm)	S (mm)
16	9.525	16.50	3.47

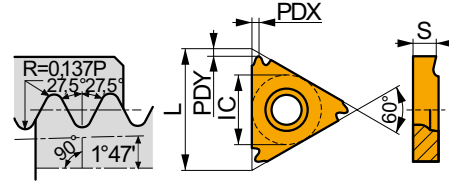

Kesme hızı (vc) için uygunluk ve başlangıç değerleri. Daha ileri hesaplamalar için İşleme Hesaplayıcısı uygulamasına başvurun.

Product	RE (mm)	P	M	K	N	S	H	TP (mm)	TPI	PDX (mm)	PDY (mm)
		vc (m/min)	vc (m/min)	vc (m/min)	vc (m/min)	vc (m/min)	vc (m/min)				

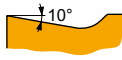

TN BSPT ER dış, sağ kesme yönlü, BSPT dişler için, darbesiz kesim.

TN 16ER280BSPT	T8030	–	160	95	150	480	40	–	–	28.0	0.8	0.8
TN 16ER190BSPT	T8030	–	160	95	150	480	40	–	–	19.0	1.5	1.2
TN 16ER140BSPT	T8030	–	160	95	150	480	40	–	–	14.0	1.5	1.2
TN 16ER110BSPT	T8030	–	160	95	150	480	40	–	–	11.0	1.5	1.2

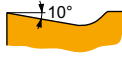
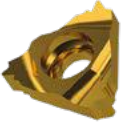

TN BSPT EL dış, sol kesme yönlü, BSPT dişler için, darbesiz kesim.

TN 16EL280BSPT	T8030	–	160	95	150	480	40	–	–	28.0	0.8	0.8
TN 16EL190BSPT	T8030	–	160	95	150	480	40	–	–	19.0	1.5	1.2
TN 16EL140BSPT	T8030	–	160	95	150	480	40	–	–	14.0	1.5	1.2
TN 16EL110BSPT	T8030	–	160	95	150	480	40	–	–	11.0	1.5	1.2

TN BSPT INT

	IC (mm)	L (mm)	S (mm)
16	9.525	16.50	3.47

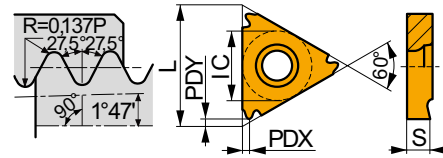

Kesme hızı (vc) için uygunluk ve başlangıç değerleri. Daha ileri hesaplamalar için İşleme Hesaplayıcısı uygulamasına başvurun.

Product	RE (mm)	P	M	K	N	S	H	TP (mm)	TPI	PDX (mm)	PDY (mm)
		vc (m/min)	vc (m/min)	vc (m/min)	vc (m/min)	vc (m/min)	vc (m/min)				

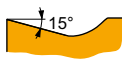
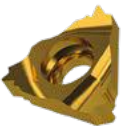

TN BSPT NR iç, sağ kesme yönlü, BSPT dişler için, darbesiz kesim.

TN 16NR280BSPT	T8030	–	160	95	150	480	40	–	–	28.0	0.8	0.8
TN 16NR190BSPT	T8030	–	160	95	150	480	40	–	–	19.0	1.5	1.2

Kesme hızı (vc) için uygunluk ve başlangıç değerleri. Daha ileri hesaplamalar için İşleme Hesaplayıcısı uygulamasına başvurun.

Product	RE (mm)	P vc (m/min)	M vc (m/min)	K vc (m/min)	N vc (m/min)	S vc (m/min)	H vc (m/min)	TP (mm)	TPI	PDX (mm)	PDY (mm)

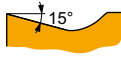
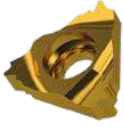

TN BSPT NR iç, sağ kesme yönlü, BSPT dişler için, darbesiz kesim.

TN 16NR140BSPT	T8030	–	■	160	■	95	■	150	☑	480	☑	40	–	–	14.0	1.5	1.2
TN 16NR110BSPT	T8030	–	■	160	■	95	■	150	☑	480	☑	40	–	–	11.0	1.5	1.2

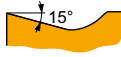

TN BSPT NL iç, sol kesme yönlü, BSPT dişler için, darbesiz kesim.

TN 16NL280BSPT	T8030	–	■	160	■	95	■	150	☑	480	☑	40	–	–	28.0	0.8	0.8
TN 16NL190BSPT	T8030	–	■	160	■	95	■	150	☑	480	☑	40	–	–	19.0	1.5	1.2
TN 16NL140BSPT	T8030	–	■	160	■	95	■	150	☑	480	☑	40	–	–	14.0	1.5	1.2
TN 16NL110BSPT	T8030	–	■	160	■	95	■	150	☑	480	☑	40	–	–	11.0	1.5	1.2

TN NPT EXT



	IC (mm)	L (mm)	S (mm)
16	9.525	16.50	3.47

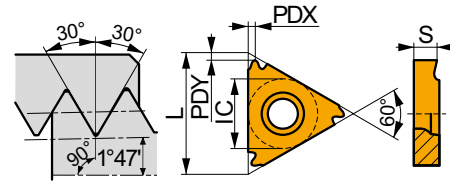

Kesme hızı (vc) için uygunluk ve başlangıç değerleri. Daha ileri hesaplamalar için İşleme Hesaplayıcısı uygulamasına başvurun.

Product	RE (mm)	P vc (m/min)	M vc (m/min)	K vc (m/min)	N vc (m/min)	S vc (m/min)	H vc (m/min)	TP (mm)	TPI	PDX (mm)	PDY (mm)

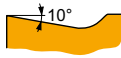

TN NPT ER dış, sağ kesme yönlü, NPT dişler için, darbesiz kesim.

TN 16ER270NPT	T8030	–	■	160	■	95	■	150	☑	480	☑	40	–	–	27.0	0.8	0.7
TN 16ER180NPT	T8030	–	■	160	■	95	■	150	☑	480	☑	40	–	–	18.0	0.8	0.7
TN 16ER140NPT	T8010	–	■	175	☑	105	■	165	–	–	☑	40	–	–	14.0	1.5	1.1
	T8030	–	■	160	■	95	■	150	☑	480	☑	40	–	–	14.0	1.5	1.1
TN 16ER115NPT	T8010	–	■	175	☑	105	■	165	–	–	☑	40	–	–	11.5	1.5	1.1
	T8030	–	■	160	■	95	■	150	☑	480	☑	40	–	–	11.5	1.5	1.1
TN 16ER080NPT	T8030	–	■	160	■	95	■	150	☑	480	☑	40	–	–	8.0	1.6	1.1

TN NPT INT

PRAMET

	IC (mm)	L (mm)	S (mm)
11	6.350	11.00	3.00
16	9.525	16.50	3.47

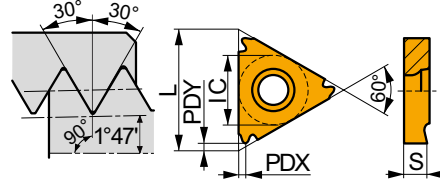

Kesme hızı (vc) için uygunluk ve başlangıç değerleri. Daha ileri hesaplamalar için İşleme Hesaplayıcısı uygulamasına başvurun.

Product	RE (mm)	P	M	K	N	S	H	TP (mm)	TPI	PDX (mm)	PDY (mm)
		vc (m/min)	vc (m/min)	vc (m/min)	vc (m/min)	vc (m/min)	vc (m/min)				

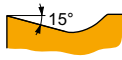
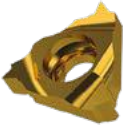

TN NPT NR iç, sağ kesme yönlü, NPT dişler için, darbesiz kesim.

TN 11NR180NPT	T8030	-	160	95	150	480	40	-	-	18.0	0.8	0.7
TN 11NR140NPT	T8030	-	160	95	150	480	40	-	-	14.0	1.0	0.7
TN 16NR140NPT	T8010	-	175	105	165	-	40	-	-	14.0	1.5	1.1
	T8030	-	160	95	150	480	40	-	-	14.0	1.5	1.1
TN 16NR115NPT	T8010	-	175	105	165	-	40	-	-	11.5	1.5	1.1
	T8030	-	160	95	150	480	40	-	-	11.5	1.5	1.1
TN 16NR080NPT	T8030	-	160	95	150	480	40	-	-	8.0	1.6	1.1

TN TR EXT

PRAMET

	IC (mm)	L (mm)	S (mm)
16	9.525	16.50	3.47
22	12.700	22.00	4.71

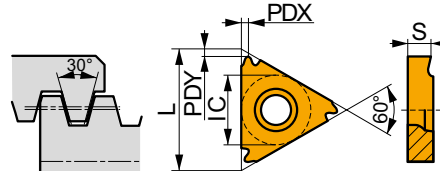

Kesme hızı (vc) için uygunluk ve başlangıç değerleri. Daha ileri hesaplamalar için İşleme Hesaplayıcısı uygulamasına başvurun.

Product	RE (mm)	P	M	K	N	S	H	TP (mm)	TPI	PDX (mm)	PDY (mm)
		vc (m/min)	vc (m/min)	vc (m/min)	vc (m/min)	vc (m/min)	vc (m/min)				

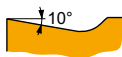

TN TR ER dış, sağ kesme yönlü, Trapez dişler için, darbesiz kesim.

TN 16ER150TR	T8030	-	160	95	150	480	40	1.50	-	0.8	0.9
TN 16ER200TR	T8030	-	160	95	150	480	40	2.00	-	1.5	1.3
TN 16ER300TR	T8030	-	160	95	150	480	40	3.00	-	1.6	1.3
TN 22ER400TR	T8030	-	160	95	150	480	40	4.00	-	2.2	1.8
TN 22ER500TR	T8030	-	160	95	150	480	40	5.00	-	2.2	1.8

Kesme hızı (vc) için uygunluk ve başlangıç değerleri. Daha ileri hesaplamalar için İşleme Hesaplayıcısı uygulamasına başvurun.

Product	RE (mm)	P vc (m/min)	M vc (m/min)	K vc (m/min)	N vc (m/min)	S vc (m/min)	H vc (m/min)	TP (mm)	TPI	PDX (mm)	PDY (mm)

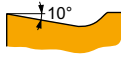

TN TR EL dış, sol kesme yönlü, Trapez dişler için, darbesiz kesim.

TN 16EL150TR	T8030	-	■	160	■	95	■	150	☑	480	☑	40	-	1.50	-	0.8	0.9
TN 16EL200TR	T8030	-	■	160	■	95	■	150	☑	480	☑	40	-	2.00	-	1.5	1.3
TN 16EL300TR	T8030	-	■	160	■	95	■	150	☑	480	☑	40	-	3.00	-	1.6	1.3
TN 22EL400TR	T8030	-	■	160	■	95	■	150	☑	480	☑	40	-	4.00	-	2.2	1.8
TN 22EL500TR	T8030	-	■	160	■	95	■	150	☑	480	☑	40	-	5.00	-	2.2	1.8

TN TR INT

PRAMET

	IC (mm)	L (mm)	S (mm)
16	9.525	16.50	3.47
22	12.700	22.00	4.71

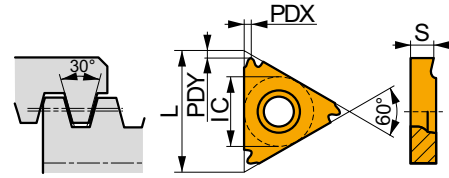

Kesme hızı (vc) için uygunluk ve başlangıç değerleri. Daha ileri hesaplamalar için İşleme Hesaplayıcısı uygulamasına başvurun.

Product	RE (mm)	P vc (m/min)	M vc (m/min)	K vc (m/min)	N vc (m/min)	S vc (m/min)	H vc (m/min)	TP (mm)	TPI	PDX (mm)	PDY (mm)

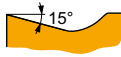

TN TR NR iç, sağ kesme yönlü, Trapez dişler için, darbesiz kesim.

TN 16NR150TR	T8030	-	■	160	■	95	■	150	☑	480	☑	40	-	1.50	-	0.8	0.9
TN 16NR200TR	T8030	-	■	160	■	95	■	150	☑	480	☑	40	-	2.00	-	1.5	1.3
TN 16NR300TR	T8030	-	■	160	■	95	■	150	☑	480	☑	40	-	3.00	-	1.6	1.3
TN 22NR400TR	T8030	-	■	160	■	95	■	150	☑	480	☑	40	-	4.00	-	2.2	1.8
TN 22NR500TR	T8030	-	■	160	■	95	■	150	☑	480	☑	40	-	5.00	-	2.2	1.8

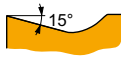

TN TR NL iç, sol kesme yönlü, Trapez dişler için, darbesiz kesim.

TN 16NL150TR	T8030	-	■	160	■	95	■	150	☑	480	☑	40	-	1.50	-	0.8	0.9
TN 16NL200TR	T8030	-	■	160	■	95	■	150	☑	480	☑	40	-	2.00	-	1.5	1.3
TN 16NL300TR	T8030	-	■	160	■	95	■	150	☑	480	☑	40	-	3.00	-	1.6	1.3
TN 22NL400TR	T8030	-	■	160	■	95	■	150	☑	480	☑	40	-	4.00	-	2.2	1.8
TN 22NL500TR	T8030	-	■	160	■	95	■	150	☑	480	☑	40	-	5.00	-	2.2	1.8

TN TR-S EXT

PRAMET

	IC (mm)	L (mm)	S (mm)
22	12.700	22.00	4.60

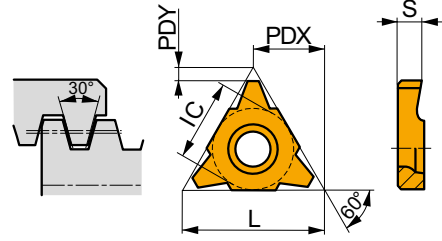

Kesme hızı (vc) için uygunluk ve başlangıç değerleri. Daha ileri hesaplamalar için İşleme Hesaplayıcısı uygulamasına başvurun.

Product	RE (mm)	P	M	K	N	S	H	TP (mm)	TPI	PDX (mm)	PDY (mm)
		vc (m/min)	vc (m/min)	vc (m/min)	vc (m/min)	vc (m/min)	vc (m/min)				

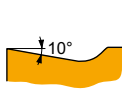

TN TR-S PP iç, sol ve sağ kesme yönlü, Trapez dişler için, darbesiz kesim.

TN 22EN600TR	T8030	-	160	95	150	480	40	-	6.00	-	11.0	1.9
TN 22EN700TR	T8030	-	160	95	150	480	40	-	7.00	-	11.0	2.3

TN TR-S INT

PRAMET

	IC (mm)	L (mm)	S (mm)
22	12.700	22.00	4.60

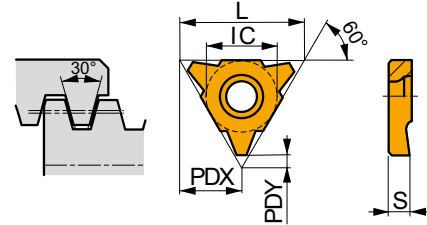

Kesme hızı (vc) için uygunluk ve başlangıç değerleri. Daha ileri hesaplamalar için İşleme Hesaplayıcısı uygulamasına başvurun.

Product	RE (mm)	P	M	K	N	S	H	TP (mm)	TPI	PDX (mm)	PDY (mm)
		vc (m/min)	vc (m/min)	vc (m/min)	vc (m/min)	vc (m/min)	vc (m/min)				

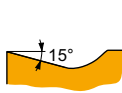

TN M60-S PP NN iç, sağ ve sol kesme yönlü, Metrik ve Birleşik dişler için, darbesiz kesim.

TN 22NN600TR	T8030	-	160	95	150	480	40	-	6.00	-	11.0	1.9
TN 22NN700TR	T8030	-	160	95	150	480	40	-	7.00	-	11.0	2.3

TN ACME EXT

	IC (mm)	L (mm)	S (mm)
16	9.525	16.50	3.47
22	12.700	22.00	4.71

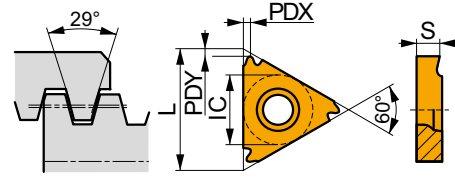

Kesme hızı (vc) için uygunluk ve başlangıç değerleri. Daha ileri hesaplamalar için İşleme Hesaplayıcısı uygulamasına başvurun.

Product	RE (mm)	P vc (m/min)	M vc (m/min)	K vc (m/min)	N vc (m/min)	S vc (m/min)	H vc (m/min)	TP (mm)	TPI	PDX (mm)	PDY (mm)

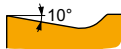

TN ACME ER dış, sağ kesme yönlü, ACME dişler için, darbesiz kesim.

TN 16ER120ACME	T8030	-	160	95	150	480	40	-	-	12.0	1.5	1.3
TN 16ER100ACME	T8030	-	160	95	150	480	40	-	-	10.0	1.5	1.3
TN 16ER080ACME	T8030	-	160	95	150	480	40	-	-	8.0	1.5	1.3
TN 22ER060ACME	T8030	-	160	95	150	480	40	-	-	6.0	2.5	2.0
TN 22ER050ACME	T8030	-	160	95	150	480	40	-	-	5.0	2.3	2.0

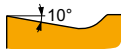

TN ACME EL dış, sol kesme yönlü, ACME dişler için, darbesiz kesim.

TN 16EL120ACME	T8030	-	160	95	150	480	40	-	-	12.0	1.5	1.3
TN 16EL100ACME	T8030	-	160	95	150	480	40	-	-	10.0	1.5	1.3
TN 16EL080ACME	T8030	-	160	95	150	480	40	-	-	8.0	1.5	1.3
TN 22EL060ACME	T8030	-	160	95	150	480	40	-	-	6.0	2.5	2.0
TN 22EL050ACME	T8030	-	160	95	150	480	40	-	-	5.0	2.3	2.0

TN ACME INT

	IC (mm)	L (mm)	S (mm)
16	9.525	16.50	3.47
22	12.700	22.00	4.71

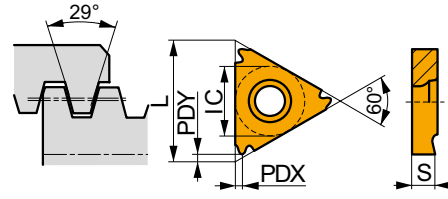

Kesme hızı (vc) için uygunluk ve başlangıç değerleri. Daha ileri hesaplamalar için İşleme Hesaplayıcısı uygulamasına başvurun.

Product	RE (mm)	P	M	K	N	S	H	TP (mm)	TPI	PDX (mm)	PDY (mm)
		vc (m/min)	vc (m/min)	vc (m/min)	vc (m/min)	vc (m/min)	vc (m/min)				



TN ACME NR iç, sağ kesme yönlü, ACME dişler için, darbesiz kesim.

TN 16NR120ACME	T8030	–	160	95	150	480	40	–	–	12.0	1.5	1.3
TN 16NR100ACME	T8030	–	160	95	150	480	40	–	–	10.0	1.5	1.3
TN 16NR080ACME	T8030 ¹⁾	–	160	95	150	480	40	–	–	8.0	1.5	1.3
TN 22NR060ACME	T8030	–	160	95	150	480	40	–	–	6.0	2.5	2.0
TN 22NR050ACME	T8030	–	160	95	150	480	40	–	–	5.0	2.3	2.0



TN ACME NL iç, sol kesme yönlü, ACME dişler için, darbesiz kesim.

TN 16NL120ACME	T8030	–	160	95	150	480	40	–	–	12.0	1.5	1.3
TN 16NL100ACME	T8030	–	160	95	150	480	40	–	–	10.0	1.5	1.3
TN 16NL080ACME	T8030 ¹⁾	–	160	95	150	480	40	–	–	8.0	1.5	1.3
TN 22NL060ACME	T8030	–	160	95	150	480	40	–	–	6.0	2.5	2.0
TN 22NL050ACME	T8030	–	160	95	150	480	40	–	–	5.0	2.3	2.0

¹⁾ Toolholders have to be modified.

NEW**TN STACME EXT****PRAMET**

	IC (mm)	L (mm)	S (mm)
16	9.525	16.50	3.47

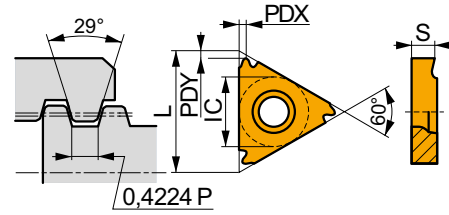

Kesme hızı (vc) için uygunluk ve başlangıç değerleri. Daha ileri hesaplamalar için İşleme Hesaplayıcısı uygulamasına başvurun.

Product	RE (mm)	P vc (m/min)	M vc (m/min)	K vc (m/min)	N vc (m/min)	S vc (m/min)	H vc (m/min)	TP (mm)	TPI	PDX (mm)	PDY (mm)



TN STACME ER dış, sağ kesme yönlü, STACME dişler için, darbesiz kesim.

TN 16ER160STACME	T8030	–	■	160	■	95	■	150	☑	480	☑	40	–	–	16.0	0.8	0.8
TN 16ER120STACME	T8030	–	■	160	■	95	■	150	☑	480	☑	40	–	–	12.0	0.8	0.8
TN 16ER100STACME	T8030	–	■	160	■	95	■	150	☑	480	☑	40	–	–	10.0	1.5	1.3
TN 16ER080STACME	T8030	–	■	160	■	95	■	150	☑	480	☑	40	–	–	8.0	1.5	1.3
TN 16ER060STACME	T8030	–	■	160	■	95	■	150	☑	480	☑	40	–	–	6.0	1.4	1.3

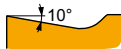
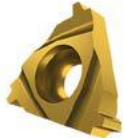

TN STACME EL dış, sol kesme yönlü, STACME dişler için, darbesiz kesim.

TN 16EL160STACME	T8030	–	■	160	■	95	■	150	☑	480	☑	40	–	–	16.0	0.8	0.8
TN 16EL120STACME	T8030	–	■	160	■	95	■	150	☑	480	☑	40	–	–	12.0	0.8	0.8
TN 16EL100STACME	T8030	–	■	160	■	95	■	150	☑	480	☑	40	–	–	10.0	1.5	1.3
TN 16EL080STACME	T8030	–	■	160	■	95	■	150	☑	480	☑	40	–	–	8.0	1.5	1.3
TN 16EL060STACME	T8030	–	■	160	■	95	■	150	☑	480	☑	40	–	–	6.0	1.4	1.3

NEW**TN STACME INT****PRAMET**

	IC (mm)	L (mm)	S (mm)
16	9.525	16.50	3.47

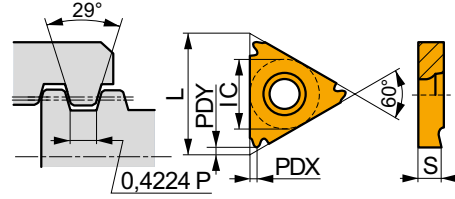

Kesme hızı (vc) için uygunluk ve başlangıç değerleri. Daha ileri hesaplamalar için İşleme Hesaplayıcısı uygulamasına başvurun.

Product	RE (mm)	P	M	K	N	S	H	TP (mm)	TPI	PDX (mm)	PDY (mm)
		vc (m/min)	vc (m/min)	vc (m/min)	vc (m/min)	vc (m/min)	vc (m/min)				



TN STACME NR iç, aç kesme yönlü, STACME dişler için, darbesiz kesim.

TN 16NR160STACME	T8030	–	■ 160	■ 95	■ 150	■ 480	■ 40	–	–	16.0	0.8	0.8
TN 16NR120STACME	T8030	–	■ 160	■ 95	■ 150	■ 480	■ 40	–	–	12.0	0.8	0.8
TN 16NR100STACME	T8030	–	■ 160	■ 95	■ 150	■ 480	■ 40	–	–	10.0	1.5	1.3
TN 16NR080STACME	T8030	–	■ 160	■ 95	■ 150	■ 480	■ 40	–	–	8.0	1.5	1.3
TN 16NR060STACME	T8030¹⁾	–	■ 160	■ 95	■ 150	■ 480	■ 40	–	–	6.0	1.3	1.3

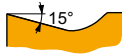

TN STACME NL iç, sol kesme yönlü, STACME dişler için, darbesiz kesim.

TN 16NL160STACME	T8030	–	■ 160	■ 95	■ 150	■ 480	■ 40	–	–	16.0	0.8	0.8
TN 16NL120STACME	T8030	–	■ 160	■ 95	■ 150	■ 480	■ 40	–	–	12.0	0.8	0.8
TN 16NL100STACME	T8030	–	■ 160	■ 95	■ 150	■ 480	■ 40	–	–	10.0	1.5	1.3
TN 16NL080STACME	T8030	–	■ 160	■ 95	■ 150	■ 480	■ 40	–	–	8.0	1.5	1.3
TN 16NL060STACME	T8030¹⁾	–	■ 160	■ 95	■ 150	■ 480	■ 40	–	–	6.0	1.3	1.3

¹⁾ Toolholders have to be modified.

TN API RD EXT

	IC (mm)	L (mm)	S (mm)
16	9.525	16.50	3.47

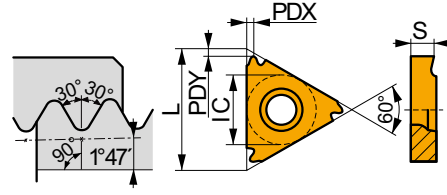

Kesme hızı (vc) için uygunluk ve başlangıç değerleri. Daha ileri hesaplamalar için İşleme Hesaplayıcısı uygulamasına başvurun.

Product	RE (mm)	P	M	K	N	S	H	TP (mm)	TPI	PDX (mm)	PDY (mm)
		vc (m/min)	vc (m/min)	vc (m/min)	vc (m/min)	vc (m/min)	vc (m/min)				

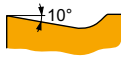
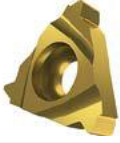

TN API ER dış, sağ kesme yönlü, API dişler için, darbesiz kesim.

TN 16ER100API-RD01	T8030	-	■	160	■	95	■	150	■	480	■	40	-	-	10.0	1.5	1.2
TN 16ER080API-RD01	T8030	-	■	160	■	95	■	150	■	480	■	40	-	-	8.0	1.5	1.2

TN API RD INT

	IC (mm)	L (mm)	S (mm)
16	9.525	16.50	3.47

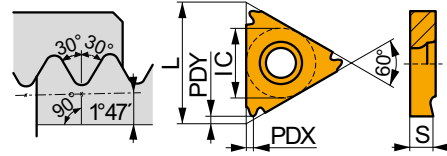

Kesme hızı (vc) için uygunluk ve başlangıç değerleri. Daha ileri hesaplamalar için İşleme Hesaplayıcısı uygulamasına başvurun.

Product	RE (mm)	P	M	K	N	S	H	TP (mm)	TPI	PDX (mm)	PDY (mm)
		vc (m/min)	vc (m/min)	vc (m/min)	vc (m/min)	vc (m/min)	vc (m/min)				

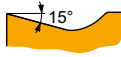
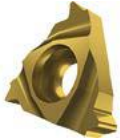

TN API NR iç, sağ kesme yönlü, API dişler için, darbesiz kesim.

TN 16NR100API-RD01	T8030	-	■	160	■	95	■	150	■	480	■	40	-	-	10.0	1.5	1.2
TN 16NR080API-RD01	T8030	-	■	160	■	95	■	150	■	480	■	40	-	-	8.0	1.5	1.2

TN RD EXT

PRAMET

	IC (mm)	L (mm)	S (mm)
16	9.525	16.50	3.47
22	12.700	22.00	4.71

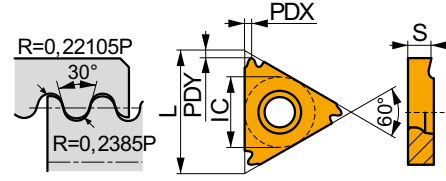

Kesme hızı (vc) için uygunluk ve başlangıç değerleri. Daha ileri hesaplamalar için İşleme Hesaplayıcısı uygulamasına başvurun.

Product	RE (mm)	P	M	K	N	S	H	TP (mm)	TPI	PDX (mm)	PDY (mm)
		vc (m/min)	vc (m/min)	vc (m/min)	vc (m/min)	vc (m/min)	vc (m/min)				

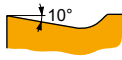

TN RD ER dış, sağ kesme yönlü, Metrik Dairesel dişler için, darbesiz kesim.

TN 16ER100RD	T8030	-	160	95	150	480	40	-	-	10.0	1.5	1.2
TN 16ER080RD	T8030	-	160	95	150	480	40	-	-	8.0	1.5	1.2
TN 16ER060RD	T8030 ¹⁾	-	160	95	150	480	40	-	-	6.0	1.5	1.2
TN 22ER060RD	T8030	-	160	95	150	480	40	-	-	6.0	2.5	1.8

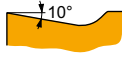

TN RD EL dış, sol kesme yönlü, Metrik Dairesel dişler için, darbesiz kesim.

TN 16EL100RD	T8030	-	160	95	150	480	40	-	-	10.0	1.5	1.2
TN 16EL080RD	T8030	-	160	95	150	480	40	-	-	8.0	1.5	1.2
TN 16EL060RD	T8030 ¹⁾	-	160	95	150	480	40	-	-	6.0	1.5	1.2
TN 22EL060RD	T8030	-	160	95	150	480	40	-	-	6.0	2.5	1.8

¹⁾ Toolholders have to be modified.

TN RD INT

PRAMET

	IC (mm)	L (mm)	S (mm)
16	9.525	16.50	3.47
22	12.700	22.00	4.71

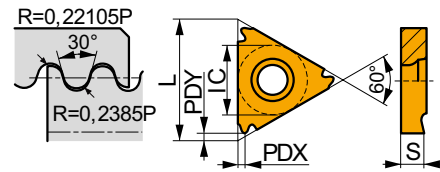

Kesme hızı (vc) için uygunluk ve başlangıç değerleri. Daha ileri hesaplamalar için İşleme Hesaplayıcısı uygulamasına başvurun.

Product	RE (mm)	P	M	K	N	S	H	TP (mm)	TPI	PDX (mm)	PDY (mm)
		vc (m/min)	vc (m/min)	vc (m/min)	vc (m/min)	vc (m/min)	vc (m/min)				

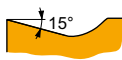
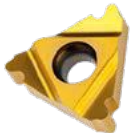

TN RD NR iç, sol kesme yönlü, Metrik Dairesel dişler için, darbesiz kesim.

TN 16NR100RD	T8030	-	160	95	150	480	40	-	-	10.0	1.5	1.2
TN 16NR080RD	T8030	-	160	95	150	480	40	-	-	8.0	1.5	1.2

Kesme hızı (vc) için uygunluk ve başlangıç değerleri. Daha ileri hesaplamalar için İşleme Hesaplayıcısı uygulamasına başvurun.

Product	RE (mm)	P	M	K	N	S	H	TP	TPI	PDX	PDY

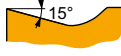

TN RD NR iç, sol kesme yönlü, Metrik Dairesel dişler için, darbesiz kesim.

TN 16NR060RD	T8030 ¹⁾	–	■	160	■	95	■	150	☑	480	☑	40	–	–	6.0	1.5	1.2
TN 22NR060RD	T8030	–	■	160	■	95	■	150	☑	480	☑	40	–	–	6.0	2.5	1.8



TN RD NL iç, sol kesme yönlü, Metrik Dairesel dişler için, darbesiz kesim.

TN 16NL100RD	T8030	–	■	160	■	95	■	150	☑	480	☑	40	–	–	10.0	1.5	1.2
TN 16NL080RD	T8030	–	■	160	■	95	■	150	☑	480	☑	40	–	–	8.0	1.5	1.2
TN 16NL060RD	T8030 ¹⁾	–	■	160	■	95	■	150	☑	480	☑	40	–	–	6.0	1.5	1.2
TN 22NL060RD	T8030	–	■	160	■	95	■	150	☑	480	☑	40	–	–	6.0	2.5	1.8

¹⁾ Toolholders have to be modified.

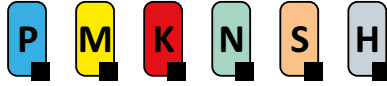
SE(RL)

PRAMET

S**TN 16 veya 22 Uç için Vida Sıkmalı Dış Kateri**

TN16 veya 22 EN uçlar için Sağ/Sol dış kateri. Metrik veya inç profiller için uygundur. Ayrıca basit kanal açma işlemleri için de kullanılabilir. Gövde uzun takım ömrü için işlem görmüştür.

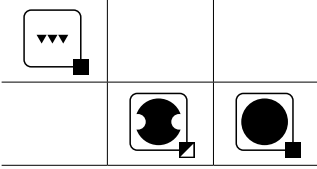
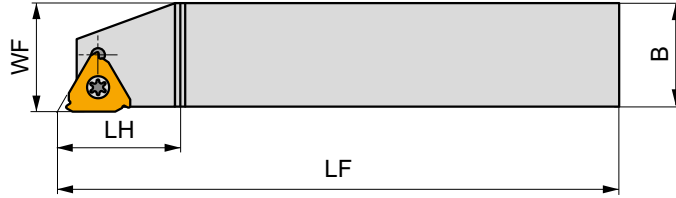
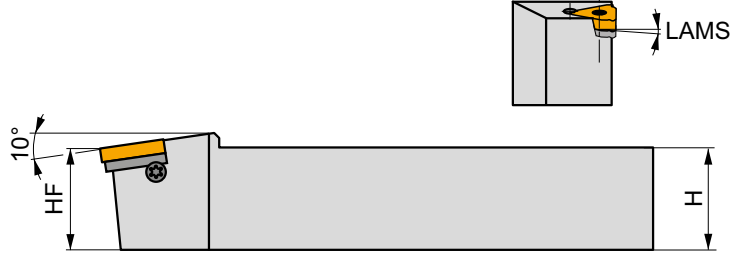
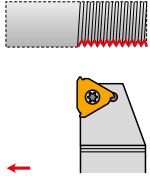

Product	H	H̄	B	WF	LF	H̄	LAMS		
	(mm)	(mm)	(mm)	(mm)	(mm)	(mm)	(°)		
R SER 2020 K 16	20	20	20	20	125	22.5	-	GI068	Z12
SER 2525 M 16	25	25	25	25	150	24	-	GI068	Z12
SER 3225 P 16	32	32	25	25	170	24.5	-	GI068	Z12
SER 2525 M 22-A	25	25	25	25	150	25.5	-	GI071	Z13
SER 3225 P 22-A	32	32	25	25	170	25.5	-	GI071	Z13
L SEL 2020 K 16	20	20	20	20	125	22.5	-	GI068	Z12
SEL 2525 M 16	25	25	25	25	150	24	-	GI068	Z12
SEL 3225 P 16	32	32	25	25	170	24.5	-	GI068	Z12
SEL 2525 M 22-A	25	25	25	25	150	25.5	-	GI071	Z13
SEL 3225 P 22-A	32	32	25	25	170	25.5	-	GI071	Z13

GI068	TN 16ER..	TN 16EL..
GI071	TN 22ER..	TN 22EL..

		Nm							
Z12	US 3512A-T15P	3.0	M 3.5	12.7	-	HS 0304	FLAG T15P	HXK 2.5	604
Z13	US 4514A-T20	5.0	M 4.5	14	SP 0405	-	FLAG T20	-	604

SE(RL)-S**PRAMET****S****TN 22 Uç için Vida Sıkmalı Diş Kateri**

TN22 EN uçlar için Sağ/Sol diş kateri. Metrik veya inç profiller için uygundur. Gövde uzun takım ömrü için işlem görmüştür.

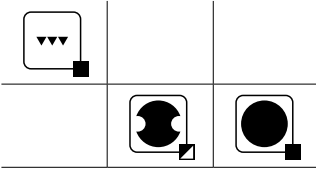
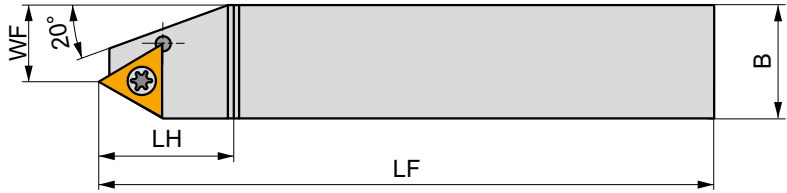
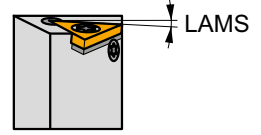
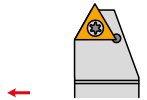
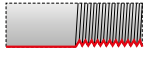

Product	H	HF	B	WF	LF	LH	LAMS		
	(mm)	(mm)	(mm)	(mm)	(mm)	(mm)	(°)		
R SER-S 2525 M 22-A	25	25	25	14	150	30	-	GI086	Z15
SER-S 3225 P 22-A	32	32	25	14	170	30	-	GI086	Z15
L SEL-S 2525 M 22-A	25	25	25	14	150	30	-	GI086	Z15
SEL-S 3225 P 22-A	32	32	25	14	170	30	-	GI086	Z15



GI086



TN 22EN..



Z15



US 4514A-T20



5.0



M 4.5



14



SP 0405



FLAG T20



604

SI(RL)



PRAMET



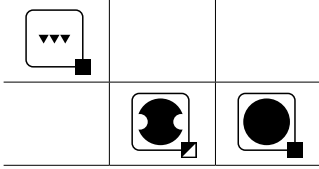
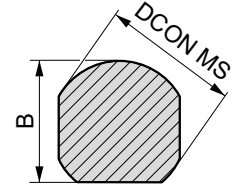
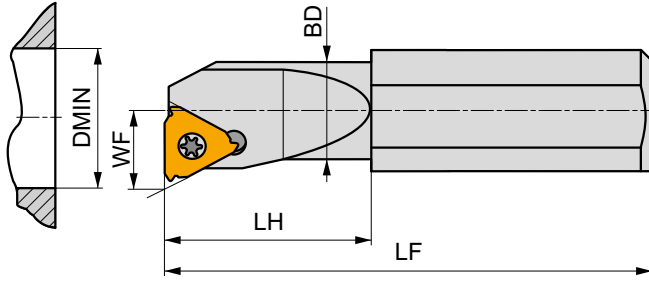
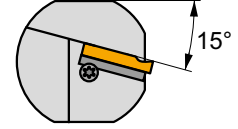
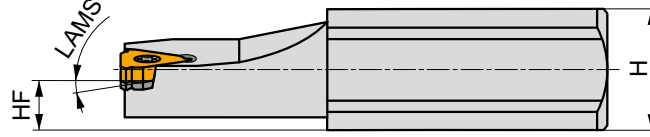
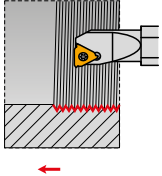









S**TN 11, 16 veya 22 Uç için Vida Sıkmalı Diş Delik Kateri**

TN11, 16 veya 22 NR/NL uçlar için Sağ/Sol delik diş kateri. Metrik veya inç profiller için uygundur. Minimum çalışma çapı Ø13mm. Ayrıca basit kanal açma işlemleri için de kullanılabilir. Ø16-40mm shaft ölçüleri. Gövde uzun takım ömrü için işlem görmüştür.



Product	B	DCON MS	DMIN	BD	WF	H	HF	LF	LH	LAMS	G1085	Z11
	(mm)	(mm)	(mm)	(mm)	(mm)	(mm)	(mm)	(mm)	(mm)	(°)		
R SIR 0010 K 11-0	14.5	16	13	10	7.45	14	7	125	25	0	-	Z11
SIR 0010 K 11-1	14.5	16	13	10	7.45	14	7	125	25	1	-	Z11
SIR 0013 M 11-0	14.5	16	16	13	9	14	7	150	32	0	-	Z11
SIR 0013 M 11-1	14.5	16	16	13	9	14	7	150	32	1	-	Z11
SIR 1416 N 16-0	14	16	22	17	11.4	14.5	7.5	160	-	0	-	Z9
SIR 1416 N 16-1	14	16	22	17	11.4	14.5	7.5	160	-	1	-	Z9
SIR 1416 N 16-2	14	16	16.5	15.5	10.6	14.5	7.5	160	40	2	✓	Z10
SIR 1820 P 16	18.5	20	27	21	13.85	18	9	170	-	-	-	Z12
SIR 2325 Q 16	23.5	25	29	26	16.55	23	11.5	180	-	-	-	Z12
SIR 2532 S 16	30	32	36	32	19.75	25	12.5	250	-	-	-	Z12
SIR 2532 S 22-2	30	32	25	25	16.65	25	12.5	250	80	2	✓	Z14
SIR 2532 S 22-A	30	32	36	32	21.65	25	12.5	250	-	-	-	Z13
SIR 3240 T 22-A	38	40	48	40	25.85	32	16	300	-	-	-	Z13
L SIL 0010 K 11-0	14.5	16	13	10	7.45	14	7	125	25	0	-	Z11
SIL 0010 K 11-1	14.5	16	13	10	7.55	14	7	125	25	1	-	Z11
SIL 0013 M 11-0	14.5	16	16	13	9	14	7	150	32	0	-	Z11
SIL 0013 M 11-1	14.5	16	16	13	9	14	7	150	32	1	-	Z11
SIL 1416 N 16-0	14	16	22	17	11.4	14.5	7.5	160	-	0	-	Z9
SIL 1416 N 16-1	14	16	22	17	11.4	14.5	7.5	160	-	1	-	Z9
SIL 1416 N 16-2	14	16	16.5	15.5	10.6	14.5	7.5	160	40	2	✓	Z10
SIL 1820 P 16	18.5	20	27	21	13.85	18	9	170	-	-	-	Z12
SIL 2325 Q 16	23.5	25	29	26	16.55	23	11.5	180	-	-	-	Z12
SIL 2532 S 16	30	32	36	32	19.75	25	12.5	250	-	-	-	Z12
SIL 2532 S 22-2	30	32	25	25	16.65	25	12.5	250	80	2	✓	Z14
SIL 2532 S 22-A	30	32	36	32	21.65	25	12.5	250	-	-	-	Z13
SIL 3240 T 22-A	38	40	48	40	25.85	32	16	300	-	-	-	Z13

		
GI022	TN 16NR..	TN 16NL..
GI076	TN 22NR..	TN 22NL..
GI085	TN 11NR..	TN 11NL..

									
Z10	US 3510A-T15P	3.0	M 3.5	10.6	-	-	FLAG T15P	-	-
Z11	US 2506-T07P	0.9	M 2.5	6.3	-	-	FLAG T07P	-	-
Z12	US 3512A-T15P	3.0	M 3.5	12.7	-	HS 0304	FLAG T15P	HXK 2.5	 604
Z13	US 4514A-T20	5.0	M 4.5	14	SP 0405	-	FLAG T20	-	 604
Z14	US 4514A-T20	5.0	M 4.5	14	-	-	FLAG T20	-	-
Z9	US 3510A-T15P	3.0	M 3.5	10.6	-	-	FLAG T15P	-	P-16

SI(RL)-S

PRAMET

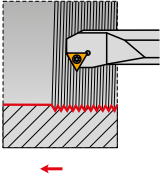
S**TN 22 Uç için Vida Sıkmalı Dış Delik Kateri**

TN22 NN uçlar için Sağ/Sol delik dış kateri. Metrik veya inç profiller için uygundur. Minimum çalışma çapı Ø39mm. Ø32-40mm shaft ölçüleri. Gövde uzun takım ömrü için işlem görmüştür.

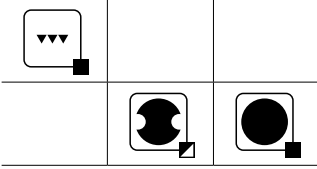
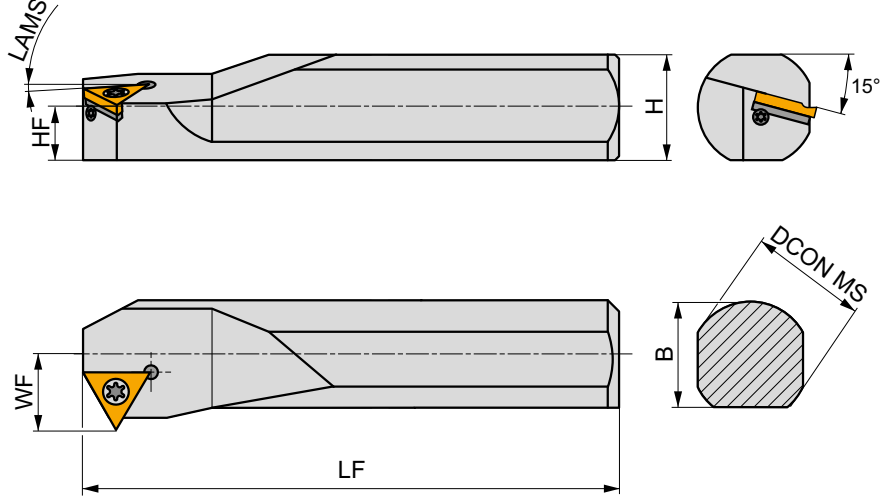

Product	B	DCON MS	DMIN	WF	H	HF	LF	LAMS		
	(mm)	(mm)	(mm)	(mm)	(mm)	(mm)	(mm)	(°)		
R SIR-S 2532 S 22-A	30	32	39	22.3	25	12.5	250	-	G1107	Z15
SIR-S 3240 T 22-A	38	40	48	27	32	16	300	-	G1107	Z15
L SIL-S 2532 S 22-A	30	32	39	22.3	25	12.5	250	-	G1107	Z15
SIL-S 3240 T 22-A	38	40	48	27	32	16	300	-	G1107	Z15



G1107



TN 22NN..



Z15



US 4514A-T20



Nm

5.0



M 4.5



14



SP 0405



FLAG T20



604



TÜM MALZEMELER

Çelik, paslanmaz çelik, dökme demir, süper alaşımlar veya demir içermeyen malzemelerin işlenmesi, hesap makinesi uygulamamızın içinde yer alır. Uygulama mağazanızdan bugün indirin. **Açıkça Güvenilir.**

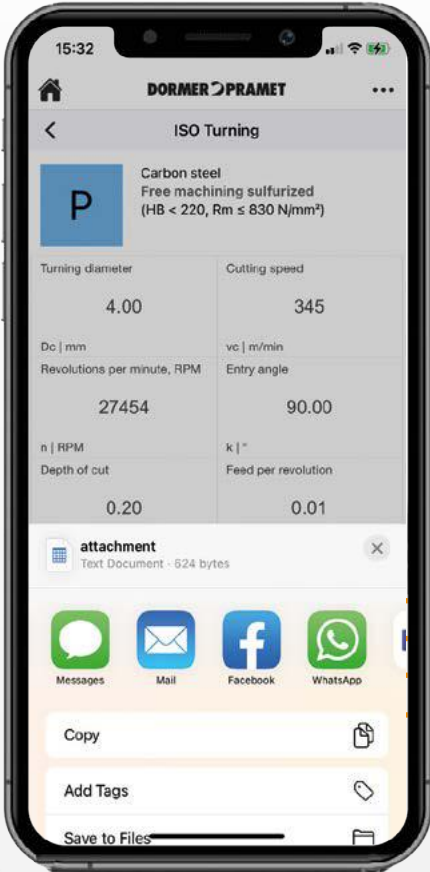









BROŞLAMA



6	ISO TORNALAMA	İŞ PARÇASI MALZEME GRUPLARI (WMG) VE ISO 13399
10		GENEL BİLGİLER
18		REHBER
57		POZİTİF KESİCİ UÇLAR
219		NEGATİF KESİCİ UÇLAR
386		KESME VE KANAL AÇMA
482		DİŞ TORNALAMA
528		BROŞLAMA
536		GENEL TEKNİK BİLGİLER

BROŞLAMA – SİMGELERE GENEL BAKIŞ

GENEL SİMGELER

 Birincil kullanım	 Finiş işleme – çok iyi yüzey kalitesi	 Stabil çalışma koşullarına uygun
 Olası kullanım	 Orta talaş işleme – iyi yüzey kalitesi	 Stabil olmayan çalışma koşullarına uygun
	 Kaba talaş işleme – sınırlanmamış yüzey pürüzlülüğü	 Çok dengesiz çalışma koşullarına uygun





ÖZELLİKLER

 İçten vargelleme	 Üniversal geniş aralık seçeneği	 Keskin kenar
---	---	--



DiĞER



 Vidanın bağlama torku [Nm]	 İçten kesme sıvısı beslemesi
---	--

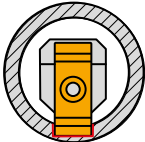

BROŞLAMA UÇLARI – NAVİGATÖR

HZ	HZ-2
	
 531	 532

BROŞLAMA TUTUCULAR – NAVİGATÖR

PHZ	PHZ-2
	
 533	 534

HZ	HZ/2..
	
03	14
04	16
05	18
06	20
08	
10	
12	

 Ø 9,5 Ø 24,7	 Ø 44 Ø 58
--	--

HZ

	IC	INSL	APMX	S	S1	CW
	(mm)	(mm)	(mm)	(mm)	(mm)	(mm)
0604-30	6.000	7.5	1.60	4.66	4.76	3.00
0604-40	6.000	8.0	2.50	4.66	4.76	4.00
0604-50	6.000	8.0	3.00	4.66	4.76	5.00
1006-60	10.000	13.5	4.20	6.25	6.35	6.00
1006-80	10.000	13.5	5.20	6.25	6.35	8.00
1309-100	13.000	18.5	6.20	9.40	9.53	10.00
1309-120	13.000	18.5	7.20	9.40	9.53	12.00

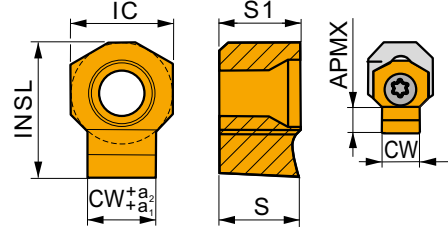

Kesme hızı (vc), ilerleme (fz) için uygunluk ve başlangıç değerleri. Daha ileri hesaplamalar için İşleme Hesaplayıcısı uygulamasına başvurun.

Product	RE	P		M		K		N		S		H		CW	CWTOLL	CWTOLU
		vc	fz	vc	fz	vc	fz	vc	fz	vc	fz	vc	fz			
	(mm)	(m/min)	(mm/tooth)	(m/min)	(mm/tooth)	(m/min)	(mm/tooth)	(m/min)	(mm/tooth)	(m/min)	(mm/tooth)	(m/min)	(mm/tooth)	(mm)	(mm)	(mm)

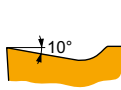

Broşlama için uygun pozitif geometri (tek kesme ağız).

HZ 1006-60 C11	333TN	-	50	0.10	30	0.09	45	0.10	-	-	-	-	6.00	0.07	0.14
HZ 1006-60 D10	333TN	-	50	0.10	30	0.09	45	0.10	-	-	-	-	6.00	0.03	0.08
HZ 1006-60 H7	333TN	-	50	0.10	30	0.09	45	0.10	-	-	-	-	6.00	0.00	0.01
HZ 1006-60 P9	333TN	-	50	0.10	30	0.09	45	0.10	-	-	-	-	6.00	-0.04	-0.01
HZ 1006-80 C11	333TN	-	50	0.10	30	0.09	45	0.10	-	-	-	-	8.00	0.08	0.17
HZ 1006-80 D10	333TN	-	50	0.10	30	0.09	45	0.10	-	-	-	-	8.00	0.04	0.10
HZ 1006-80 H7	333TN	-	50	0.10	30	0.09	45	0.10	-	-	-	-	8.00	0.00	0.02
HZ 1006-80 P9	333TN	-	50	0.10	30	0.09	45	0.10	-	-	-	-	8.00	-0.05	-0.02
HZ 1309-100 C11	333TN	-	50	0.10	30	0.09	45	0.10	-	-	-	-	10.00	0.08	0.17
HZ 1309-100 D10	333TN	-	50	0.10	30	0.09	45	0.10	-	-	-	-	10.00	0.04	0.10
HZ 1309-100 H7	333TN	-	50	0.10	30	0.09	45	0.10	-	-	-	-	10.00	0.00	0.02
HZ 1309-100 P9	333TN	-	50	0.10	30	0.09	45	0.10	-	-	-	-	10.00	-0.05	-0.02
HZ 1309-120 C11	333TN	-	50	0.10	30	0.09	45	0.10	-	-	-	-	12.00	0.10	0.21
HZ 1309-120 D10	333TN	-	50	0.10	30	0.09	45	0.10	-	-	-	-	12.00	0.05	0.12
HZ 1309-120 H7	333TN	-	50	0.10	30	0.09	45	0.10	-	-	-	-	12.00	0.00	0.02
HZ 1309-120 P9	333TN	-	50	0.10	30	0.09	45	0.10	-	-	-	-	12.00	-0.06	-0.02
HZ90 0604-30 C11	333TN	-	50	0.10	30	0.09	45	0.10	-	-	-	-	3.00	0.06	0.12
HZ90 0604-30 D10	333TN	-	50	0.10	30	0.09	45	0.10	-	-	-	-	3.00	0.02	0.06
HZ90 0604-30 H7	333TN	-	50	0.10	30	0.09	45	0.10	-	-	-	-	3.00	0.00	0.01
HZ90 0604-30 P9	333TN	-	50	0.10	30	0.09	45	0.10	-	-	-	-	3.00	-0.03	-0.01
HZ90 0604-40 C11	333TN	-	50	0.10	30	0.09	45	0.10	-	-	-	-	4.00	0.07	0.14
HZ90 0604-40 D10	333TN	-	50	0.10	30	0.09	45	0.10	-	-	-	-	4.00	0.03	0.08
HZ90 0604-40 H7	333TN	-	50	0.10	30	0.09	45	0.10	-	-	-	-	4.00	0.00	0.01
HZ90 0604-40 P9	333TN	-	50	0.10	30	0.09	45	0.10	-	-	-	-	4.00	-0.04	-0.01
HZ90 0604-50 C11	333TN	-	50	0.10	30	0.09	45	0.10	-	-	-	-	5.00	0.07	0.14
HZ90 0604-50 D10	333TN	-	50	0.10	30	0.09	45	0.10	-	-	-	-	5.00	0.03	0.08
HZ90 0604-50 H7	333TN	-	50	0.10	30	0.09	45	0.10	-	-	-	-	5.00	0.00	0.01
HZ90 0604-50 P9	333TN	-	50	0.10	30	0.09	45	0.10	-	-	-	-	5.00	-0.04	-0.01

HZ-2

	INSL (mm)	APMX (mm)	S (mm)	S1 (mm)	CW (mm)
14-14	36.0	8.00	13.90	14.00	14.00
16-16	36.0	9.00	13.90	14.00	16.00
18-18	45.0	12.00	15.90	16.00	18.00
20-20	45.0	13.00	15.90	16.00	20.00

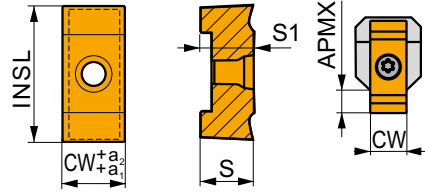

Kesme hızı (vc), ilerleme (fz) için uygunluk ve başlangıç değerleri. Daha ileri hesaplamalar için İşleme Hesaplayıcısı uygulamasına başvurun.

Product	RE (mm)	P		M		K		N		S		H		CW (mm)	CWTOLL (mm)	CWTOLU (mm)
		vc (m/min)	fz (mm/tooth)	vc (m/min)	fz (mm/tooth)	vc (m/min)	fz (mm/tooth)	vc (m/min)	fz (mm/tooth)	vc (m/min)	fz (mm/tooth)	vc (m/min)	fz (mm/tooth)			

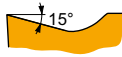

Broşlama için uygun pozitif geometri (çift kesme ağızı).

HZ/2 14-14 C11	333TN	-	50	0.10	30	0.09	45	0.10	-	-	-	-	14.00	0.10	0.21
HZ/2 14-14 H7	333TN	-	50	0.10	30	0.09	45	0.10	-	-	-	-	14.00	0.00	0.02
HZ/2 14-14 P9	333TN	-	50	0.10	30	0.09	45	0.10	-	-	-	-	14.00	-0.06	-0.02
HZ/2 16-16 C11	333TN	-	50	0.10	30	0.09	45	0.10	-	-	-	-	16.00	0.10	0.21
HZ/2 16-16 H7	333TN	-	50	0.10	30	0.09	45	0.10	-	-	-	-	16.00	0.00	0.02
HZ/2 16-16 P9	333TN	-	50	0.10	30	0.09	45	0.10	-	-	-	-	16.00	-0.06	-0.02
HZ/2 18-18 C11	333TN	-	50	0.10	30	0.09	45	0.10	-	-	-	-	18.00	0.10	0.21
HZ/2 18-18 H7	333TN	-	50	0.10	30	0.09	45	0.10	-	-	-	-	18.00	0.00	0.02
HZ/2 18-18 P9	333TN	-	50	0.10	30	0.10	45	0.10	-	-	-	-	18.00	-0.06	-0.02
HZ/2 20-20 C11	333TN	-	50	0.10	30	0.09	45	0.10	-	-	-	-	20.00	0.11	0.24
HZ/2 20-20 H7	333TN	-	50	0.10	30	0.09	45	0.10	-	-	-	-	20.00	0.00	0.02
HZ/2 20-20 P9	333TN	-	50	0.10	30	0.10	45	0.10	-	-	-	-	20.00	-0.07	-0.02

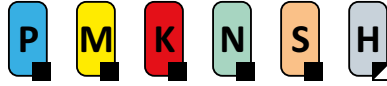
PHZ**PRAMET****S****Tek Taraflı HZ Uçlar için Küçük Çap Delik Broş Kateri**

12mm genişliğe kadar broşlama için delik kateri. Minimum çalışma çapı Ø9.5mm. Gövde uzun takım ömrü için işlem görmüştür.

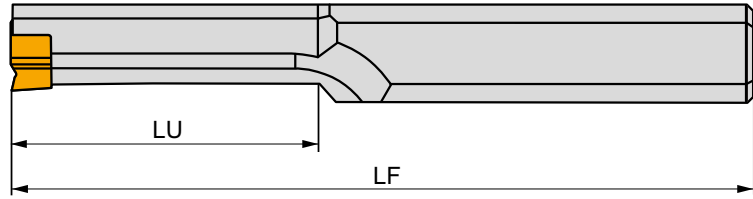
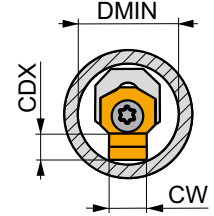
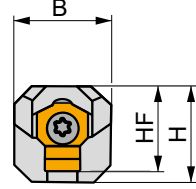
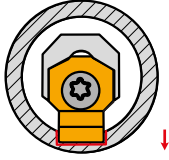

Product	H	HF	B	OAL	LU	CW	DMIN	CDX	kg	G	SH	
	(mm)	(mm)	(mm)	(mm)	(mm)	(mm)	(mm)					
N	PHZ 90 1104-06	11.3	9	8.5	160	35	3.00	9.5	1.6	0.17	GI239	SH21
	PHZ 90 1107-06	11.3	10	7	200	60	-	-	-	0.19	GI240	SH21
	PHZ 90 1111-06	11.3	12	-	200	60	-	-	-	0.19	GI240	SH21
	PHZ 1512-10	15.5	16.2	-	220	-	-	-	-	0.40	GI224	SH22
	PHZ 2014-13	20.6	21.5	-	250	-	-	-	-	0.65	GI225	SH23



GI224	HZ 1006-60	HZ 1006-80
GI225	HZ 1309-100	HZ 1309-120
GI239	HZ90 0604-30	-
GI240	HZ90 0604-40	HZ90 0604-50

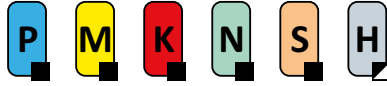

SH21	DVF 3593	0.8	M 2.5	10	TX207PLUS
SH22	DVF 2260	3.6	M 4	15	TX215PLUS
SH23	5513 020-14	8.5	M 6	18	TX225PLUS

PHZ-2

PRAMET

S

**Çift Taraflı HZ Uçlar için Büyük Çap Delik Broş Kateri**

2mm genişliğe kadar broşlama için delik kateri. Minimum çalışma çapı Ø44mm. Gövde uzun takım ömrü için işlem görmüştür.

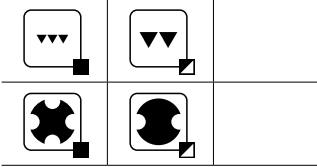
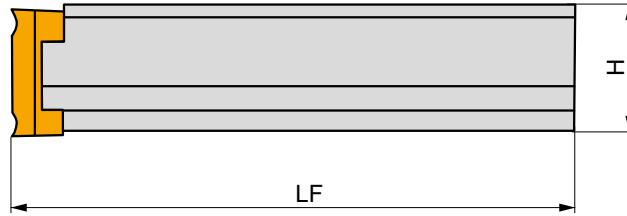
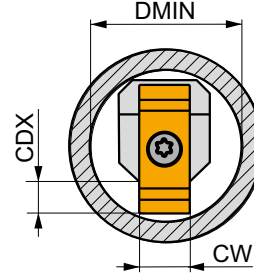
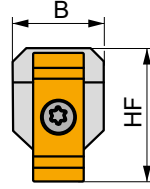
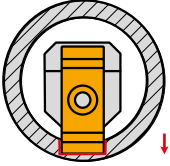

Product	H	HF	B	OAL	CW	DMIN	CDX	kg	GI235	SH23
	(mm)	(mm)	(mm)	(mm)	(mm)	(mm)	(mm)			
N PHZ/2 3625-14	36	37.5	25	300	-	44	-	1.86	GI235	SH23
	PHZ/2 4832-18	48	50	32	400	-	58	2.00	GI241	SH24

GI235	GI241
PHZ/2 14-14	PHZ/2 16-16
PHZ/2 18-18	PHZ/2 20-20

SH23	SH24
5513 020-14	5513 021-03
8.5	13.0
M 6	M 8
18	22
TX225PLUS	DMN 3124



YARDIMA HAZIR

Teknik destek ekibimiz, teknik uygulamalarımızla ilgili teknik sorularınız veya sorgularınız için her zaman yardıma hazırdır. Yerel Dormer Pramet satış ofisinize ulaşmak için iletişim bilgilerini kullanın. **Açıkça Güvenilir.**

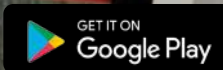
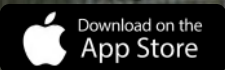
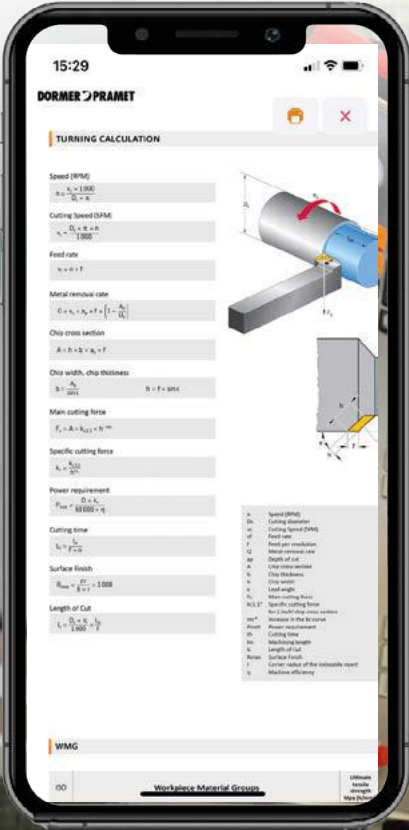

GENEL TEKNİK BİLGİLER



6	ISO TORNALAMA	İŞ PARÇASI MALZEME GRUPLARI (WMG) VE ISO 13399
10		GENEL BİLGİLER
18		REHBER
57		POZİTİF KESİCİ UÇLAR
219		NEGATİF KESİCİ UÇLAR
386		KESME VE KANAL AÇMA
482		DİŞ TORNALAMA
528		BROŞLAMA
536		GENEL TEKNİK BİLGİLER

İŞ PARÇASI MALZEME GRUPLARI (WMG)

ISO

Uygun kesme geometrisi ve takım kalitesi seçmek için iş parçası malzemesi grubu

Genel tanım

ör. çelik, paslanmaz çelik...

P M K N S H

Alt grup

Takım seçerken daha detaylı sınıflandırma için

Tanım yapıya/bileşime göre

ör. yalın karbon çeliği, alaşımlı çelik...

P M K N S H

P1

P2

P3

P4

WMG

±%10 doğrulukla kesme şartlarını seçmek için

Tanım

sertliğe/maksimum gerilme dayanımına göre

ör. 160 < 220HB, 620 < 900 n/mm² ...

P

P1

P2

P3

P4

P1.1 P1.2 P1.3

P2.1 P2.2 P2.3

P3.1 P3.2 P3.3

P4.1 P4.2 P4.3

DORMER PRAMET'İN İŞ PARÇASI MALZEMELERİ SINIFLANDIRMASI HAKKINDA

İş parçası malzeme grupları ("WMG"), belirli uygulamalardaki işleme koşulları için doğru kesici takımın ve başlangıç değerlerinin kolay ve güvenilir şekilde seçimini desteklemek için kullanılır.

Dormer Pramet iş parçası malzemelerini altı farklı renk grubunda sınıflandırır;

- **Mavi:** Çelik ve dökme çelikler (P grubu)
- **Sarı:** Paslanmaz çelik (M grubu)
- **Kırmızı:** Dökme demir (K grubu)
- **Yeşil:** Demir dışı metaller (N grubu)
- **Kahverengi:** Süper alaşımlar (S grubu)
- **Gri:** Sertleştirilmiş malzemeler (H grubu)

Bunların her biri, yapılarına ve/veya bileşimlerine göre alt gruplara ayrılır. Örneğin, P grubu çelik ve dökme çelik dört alt gruba ayrılır, yani;

- P1 – **Otomat çeliği**
- P2 – **Yalın karbon çeliği**
- P3 – **Alaşımlı çelik**
- P4 – **Takım çeliği**

Son bölüm, sertlik ve maksimum gerilme dayanımı gibi malzeme özelliklerini içerir. Bunun amacı müşterilerimize kesme hızı ve ilerleme için başlangıç değerleri de dahil komple bir takım önerisi sağlamaktır.

Bir sonraki sayfada yer alan tabloda, her bir iş parçası malzeme grubunun tanımı ve sık kullanılan işaretleme örnekleri bulunmaktadır

İŞ PARÇASI MALZEME GRUPLARI (WMG)

ISO grubu	Alt grup	WMG (İş Malzeme Grubu)	k _g	Malzeme örnekleri (AISI, EN, DIN, ÇSN, GB, SS, STN, BS, UNE, AFNOR, ASTM, GOST, UNS, UNI, ...)
P Çelik ve dökme çelik (alaşım içeriği ≤ %10 ve sertliği < 45HRC olan çelikler)	P1 Otomat çeligi (işlenebilirliği artırılmış karbonlu çelikler)	P1.1 < 240 HB sertliğinde serbest işleme süffürlü karbon çeligi	1.33	AISI 1108, EN 15522, DIN 1.0723, SS 1922, ÇSN 11120, BS 210A15, UNE F.210F, GB Y15, AFNOR 10F1, GOST A30, UNI CF10S20
		P1.2 < 180 HB sertliğinde serbest işleme süffürlü ve fosforlu karbon çeligi	1.49	AISI 1211, EN 115Mn30, DIN 1.0715, SS 1912, ÇSN 11109, BS 230M7, UNE F.2111, GB Y15, AFNOR S250, GOST A40G, UNI CF9SMn28
		P1.3 < 180 HB sertliğinde serbest işleme süffürlü/fosforlu ve kurşunlu karbon çeligi	1.53	AISI 12L13, EN 115MnPb30, DIN 1.0718, SS 1914, ÇSN 12110, BS 210M16, UNE F.2114, GB Y15Pb, AFNOR S250Pb, GOST A35G2, UNI CF10SPb20
	P2 Yalın karbon çeligi (esas olarak demir ve karbondan oluşan çelikler)	P2.1 < 180 HB sertliğinde < %0,25 C içeren yalın düşük karbonlu çelik	1.14	AISI 1015, EN C15, DIN 1.0401, SS 1350, ÇSN 11301, BS 080A15, UNE F.111, GB 15, AFNOR C18RR, GOST S22ps, UNI Fe360
		P2.2 < 240 HB sertliğinde < %0,55 C içeren yalın orta karbonlu çelik	1.00	AISI 1030, EN C30, DIN 1.0528, SS 1550, ÇSN 12031, BS 080M32, UNE F.1130, GB 30, AFNOR AF50C30, GOST 30G, UNI Fe590
		P2.3 < 300 HB sertliğinde > %0,55 C içeren yalın yüksek karbon çeligi	0.89	AISI 1060, EN C60, DIN 1.0601, SS 1655, ÇSN 12061, BS 080A62, UNE F513, GB 60, AFNOR 1C60, GOST 60G, UNI C60
	P3 Alaşımli çelik (alaşım içeriği ≤ %10 olan karbonlu çelikler)	P3.1 < 180 HB sertliğinde alaşımli çelik	0.92	AISI 5015, EN 16Mo3, DIN 1.5415, SS 2912, ÇSN 15020, BS 1501-240, UNE F.2601, GB 16Mo, AFNOR 15D3, GOST 15M, UNI 16Mo3KW
		P3.2 180 – 260 HB sertliğinde alaşımli çelik	0.74	AISI 4140, EN 42CrMo4, DIN 1.7225, SS 2244, ÇSN 15142, BS 708M40, UNE F.8232, GB 42CrMo, AFNOR 42CD4, GOST 40CHFA, UNI 42CrMo4
		P3.3 260 – 360 HB sertliğinde alaşımli çelik	0.63	AISI 4140, EN 42CrMo4, DIN 1.7225, SS 2244, ÇSN 15142, BS 708M40, UNE F.8232, GB 42CrMo, AFNOR 42CD4, GOST 40CHFA, UNI 42CrMo4
	P4 Takım çeligi (takımlar ve kalıplar için özel alaşımli çelik)	P4.1 < 26 HRC sertliğinde takım çeligi	0.55	AISI D2, EN X155CrVMo12-1, DIN 1.2370, SS 2736, ÇSN 19573, BS BD2, UNE F.520A, GB Cr12Mo1V1, AFNOR Z160CDV12, GOST Ch12MF, UNI X155CrVMo121KU
		P4.2 26 – 39 HRC sertliğinde takım çeligi	0.47	AISI D2, EN X155CrVMo12-1, DIN 1.2370, SS 2736, ÇSN 19573, BS BD2, UNE F.520A, GB Cr12Mo1V1, AFNOR Z160CDV12, GOST Ch12MF, UNI X155CrVMo121KU
		P4.3 39 – 45 HRC sertliğinde takım çeligi	0.38	AISI D2, EN X155CrVMo12-1, DIN 1.2370, SS 2736, ÇSN 19573, BS BD2, UNE F.520A, GB Cr12Mo1V1, AFNOR Z160CDV12, GOST Ch12MF, UNI X155CrVMo121KU

İŞ PARÇASI MALZEME GRUPLARI (WMG)

ISO grubu	Alt grup	WMG (İş Malzeme Grubu)	k_{vg}	Malzeme örnekleri (AISI, EN, DIN, ÇSN, GB, SS, STN, BS, UNE, AFNOR, ASTM, GOST, UNS, UNI, ...)
M Paslanmaz çelik (\geq %11 krom içeriğine sahip korozyona dayanıklı çelikler)	M1 Ferritik paslanmaz çelik (düz krom sertleşmeyen alaşımlar)	M1.1 Paslanmaz çelik, sertliği < 160 HB olan ferritik	1.22	AISI 5429, EN X7Cr14, DIN 1.4001, SS 2326, BS 434517, UNE F.3401, AFNOR Z8C12, GOST 08Ch13, UNI X6CrTi12
		M1.2 160 – 220 HB sertliğinde paslanmaz çelik, ferritik	1.03	AISI 446, EN X10CrAl24, DIN 1.4762, SS 2322, ÇSN 17113, BS 430517, UNE F.3154, GB 10Cr17, AFNOR Z10CA524, GOST 12Ch17, UNI X16Cr26
		M2.1 < 200 HB sertlikte martensitik paslanmaz çelik	1.08	AISI 430F, EN X14CrMo517, DIN 1.4104, SS 2383, ÇSN 17140, BS 410521, UNE F.3117, AFNOR Z10CF17, UNI X10Cr517
	M2 Martensitik paslanmaz çelik (düz krom sertleştirilebilir alaşımlar)	M2.2 200 – 280 HB sertliğinde martensitik paslanmaz çelik	0.89	AISI 440C, EN X105CrMo17, DIN 1.4125, SS 2385, ÇSN 17023, BS 425C11, UNE F.3402, GB 102Cr17Mo, AFNOR Z100CD17, GOST 95Ch18, UNI 6X6CrNi 13 04
		M2.3 280 – 380 HB sertliğinde martensitik paslanmaz çelik	0.75	AISI 420, EN X45Cr13, DIN 1.4034, ÇSN 17029, BS 425C11, UNE F.3405, AFNOR Z44C14, GOST 20X17H12, UNI X30Cr13
		M3.1 < 200 HB sertliğinde östenitik paslanmaz çelik	1.00	AISI 304, EN X5CrNi18-12, DIN 1.4303, SS 2352, ÇSN 17249, BS 305517, UNE F.3513, GB 10Cr18Ni12, AFNOR Z8CN18.12, UNI X7CrNi18 10
	M3 Östenitik paslanmaz çelik (krom-nikel ve krom-nikel-manganez alaşımları)	M3.2 200 – 260 HB sertliğinde östenitik paslanmaz çelik	0.86	AISI 309, EN X15CrNiSi20-12, DIN 1.4828, ÇSN 17251, BS 309S24, UNE F.3312, GB 1G23Ni13, AFNOR Z15CNS20.12, GOST 20Ch20Ni452, UNI 16CrNi23 14
		M3.3 260 – 300 HB sertliğinde östenitik paslanmaz çelik	0.77	AISI 5848, EN X45CrNiW18-9, DIN 1.4873, BS 331540, UNE F.3211, AFNOR Z35CNW514-4, UNI X45CrNiW 18 9
		M4 Süper östenitik, Duplex veya Çökeltirerek Sertleştirilmiş paslanmaz çelik ($>$ %20 Ni içeren östenitik alaşımlar, östenitik-ferritik mikro yapı veya çökeltirilmiş)	M4.1 < 300 HB sertliğinde paslanmaz çelik, östenitik-ferritik veya süper östenitik	0.75
	M4.2 300 – 380 HB sertliğinde çökeltirilmiş östenitik paslanmaz çelik		0.64	AISI 631 (17-7PH), EN X7CrNiAl17-7, DIN 1.4568, SS 2388, ÇSN 17465, BS 301513, UNE F.3217, GB 07Cr17Ni7Al, AFNOR Z9CNAl17-07, GOST 09Ch17Ni7Al, UNI X53CrMnNiN21 9

İŞ PARÇASI MALZEME GRUPLARI (WMG)

ISO grubu	Alt grup	WMG (İş Malzeme Grubu)	k_{α}	Malzeme örnekleri (AISI, EN, DIN, ÇSN, GB, SS, STN, BS, UNE, AFNOR, ASTM, GOST, UNS, UNI, ...)		
K	K1	Gri demir (GG) (ince tabakalı grafit mikro yapıya sahip demir-karbon dökümler)	K1.1	< 180 HB sertliğinde ferritik veya ferritik-perlitik gri demir	1.35	ASTM A48 Grade 20 (F11401), EN-JL-100, DIN GG-10 (0.6010), SS 0110, STN 422410, BS Grade 150, UNE FG10, GB HAT 100, AFNOR Fc10D, GOST SC 10, UNI G10
			K1.2	180 – 240 HB sertliğinde ferritik-perlitik veya perlitik gri demir	1.00	ASTM A48 Grade 30 (F12101), EN-JL-1030, DIN GG-20 (0.6020), SS 0120, STN 422420, BS Grade 220, UNE FG20, GB HT200, AFNOR Ft20D, GOST Ç420, UNI G20
			K1.3	240 – 280 HB sertliğinde perlitik gri demir	0.75	ASTM A48 Grade 50 (F13501), EN-JL-1060, DIN GG-35 (0.6035), SS 0135, STN 422435, BS Grade 350, UNE FG35, GB HAT300, AFNOR F35D, GOST SC35, UNI G35
	K2	Dövülebilir demir (GTS/GTW) (grafit içermeyen mikro yapıya sahip ısı işlem görmüş demir-karbon dökümler)	K2.1	< 160 HB sertliğinde ferritik dövülebilir demir	1.39	ASTM A602 Grade M3210 (F20000), EN-JM-1130, DIN GTS-35 (0.8135), SS 0815, BS B340/12, UNE Type A, AFNOR MN 35-10, GOST K435-10
			K2.2	160 – 200 HB sertliğinde ferritik veya perlitik dövülebilir demir	1.13	ASTM A602 Grade M4504 (F20001), EN-JM-1040, DIN GTS-50-05 (0.8045), BS P50-05, AFNOR MB 45-7
			K2.3	200 – 240 HB sertliğinde perlitik dövülebilir demir	0.90	ASTM A602 Grade M7002 (F20004), EN-JM-1140, DIN GTS-45 (0.8145), SS 0854, STN 422540, BS P 45-06, UNE Typ B, AFNOR MP 50-5, GOST K445-7, UNI GMM 45
	K3	Sünek demir (GGG) (nodüler grafit mikro yapıya sahip demir-karbon dökümler)	K3.1	< 180 HB sertliğinde sünek (nodüler/küresel) demir, ferritik	1.23	ASTM A536 Grade 60-40-18 (F32800), EN-JS-1030, DIN GGG-40 (0.7040), SS 0717, STN 422304, BS 420/12, UNE FGE 42-12, GB QT 400, AFNOR FGS 400-12, GOST B440
			K3.2	180 – 220 HB sertliğinde sünek (nodüler/küresel) demir, ferritik veya perlitik	0.94	ASTM A536 Grade 80-55-06 (F33800), EN-JS-1050, DIN GGG-50 (0.7050), SS 0727, STN 422305, BS 500/7, UNE FGE 50-7, GB QT 500-7, AFNOR FGS 500-7, GOST B450
			K3.3	220 – 260 HB sertliğinde sünek (nodüler/küresel) demir, perlitik	0.76	ASTM A536 Grade 100-70-03 (F34800), EN-JS-1060, DIN GGG-60 (0.7060), SS 0732, STN 422306, BS 600/3, UNE FG70-2, GB QT 600-3, AFNOR FGS 600-3, GOST B460
	K4	östenitik veya östempelenmiş sünek demir (Ni-Resist/ADI) (östenitik veya ösferrit mikro yapıya sahip demir-karbon alaşımlı dökümler)	K4.1	< 180 HB sertliğinde östenitik dökme demir	1.14	ASTM A439 Type 1 (L-NiCuCr 15 6 2, F41000), EN-JL-3011, DIN GGL-NiMn 13 7 (0.6652), SS 0523, BS Grade F1, AFNOR FGL-Ni13Mn7, GOST S-NiMn 13 7
			K4.2	180 – 240 HB sertliğinde östenitik dökme demir	0.86	ASTM A439 Type D-2B (S-NiCr 20 3, F43001), EN-JS-3021, DIN GGG-NiMn 23 4, SS 0776, BS Grade S2M, AFNOR FGS Ni23 Mn4, GOST ÇH19X3U
			K4.3	240 – 280 HB sertliğinde östempelenmiş sünek demir	0.63	ASTM A897 Grade 110-70-11
	K5	Sıkıştırılmış grafit demir (CGI) (solucansız grafit yapıya sahip demir-karbon dökümler)	K4.4	280 – 320 HB sertliğinde östempelenmiş sünek demir	0.54	ASTM A897 Grade 125-80-10, EN-JS-1100, DIN GGG-90 (5.3400)
			K4.5	320 – 360 HB sertliğinde östempelenmiş sünek demir	0.45	ASTM A897 Grade 2 (150-110-07), EN-JS-1110, DIN GGG-100 (5.3403)
			K5.1	< 180 HB sertliğinde solucansız, sıkıştırılmış grafit demir	1.29	ASTM A842 Grade 300, EN-GJV-300, DIN GGV 30, GOST ÇBT30,
K5	Sıkıştırılmış grafit demir (CGI) (solucansız grafit yapıya sahip demir-karbon dökümler)	K5.2	180 – 220 HB sertliğinde solucansız, sıkıştırılmış grafit demir	0.97	ASTM A842 Grade 350, EN-GJV-350, DIN GGV 35 (5.2200), GOST ÇBT30,	
		K5.3	220 – 260 HB sertliğinde solucansız, sıkıştırılmış grafit demir	0.75	ASTM A842 Grade 450, EN-GJV-450, DIN GGV 45, GOST ÇBT45,	

İŞ PARÇASI MALZEME GRUPLARI (WMG)

ISO grubu	Alt grup	WMG (İş Malzeme Grubu)	k _{vg}	Malzeme örnekleri (AISI, EN, DIN, ÇSN, GB, SS, STN, BS, UNE, AFNOR, ASTM, GOST, UNS, UNI, ...)
N Demir dışı metaller (alaşımın dahil olmak üzere kayda değer miktarda demir içermeyen metaller)	N1 Dövme alüminyum	N1.1 < 60 HB sertliğinde saf alüminyum ve dövme alüminyum alaşımları	1.33	UNS A91200, EN AL99.6, DIN 3.0205, SS 4010, STN 424009, BS 1C, UNE L-3001, GB L5, AFNOR A4, GOST AİC, UNI 3567
		N1.2 60 – 100 HB sertliğinde dövme alüminyum alaşımları	1.00	UNS A93004, EN AIMn0.5Mg0.5, DIN 3.0505, SS 4054, STN 424432, BS N31, UNE L-3831, GB LF2, AFNOR A-M1, GOST AMu, UNI 3568
		N1.3 100 – 150 HB sertliğinde dövme alüminyum alaşımları	0.67	UNS A95083, EN AIMg4.5Mn0.7, DIN 3.3547, SS 4140, STN 424415, BS N8, UNE L-3321, GB AIMg4.5Mn, AFNOR A-G4.5Mn, GOST Amg 4.5, UNI P-AIMg4.4
	N2 Döküm alüminyum	N2.1 < 75 HB sertliğinde döküm alüminyum alaşımları	0.67	UNS A02080, EN AICu45, BS LM11, STN 424331, UNE AISi1Cu, GOST AMg5K, UNI G-AISi7Mg
		N2.2 75 – 90 HB sertliğinde döküm alüminyum alaşımları	0.60	UNS A02420, EN AICu4Ni2Mg2, SS AISi7MgFe, BS LM6, STN 424519, UNE AI-7SiMg, AFNOR A-S7G, GOST AK7, UNI G-AISi7Mg
		N2.3 90 < 140 HB sertliğinde döküm alüminyum alaşımları	0.43	UNS A03360, EN G-ALCu4NiMg2, SS ALSi10Mg, STN 424336, BS LM 30, AFNOR A-S10G, UNI G-AISi9Mg
	N3 Bakır veya bakır alaşımları	N3.1 Mükemmel işleme özelliklerine sahip kolay kesilen bakır alaşımlı malzemeler	0.70	UNS C14700, EN CuPb1P, DIN 2.1498, STN 423214, BS C111, AFNOR CuZn35Pb2, GOST L63-3, UNI Cus(P0.01)
		N3.2 İyi-orta işleme özelliklerine sahip kısa talaş oluşturan bakır alaşımları	0.41	UNS C81540, EN CuNi25iCr, DIN 2.0857, STN 423220, BS NS113, UNE CuSn12, AFNOR CuZn40, GOST L60, UNI P-CuZn-40
		N3.3 Orta-kötü işleme özelliklerine sahip elektrolitik bakır ve uzun talaş oluşturan bakır alaşımları	0.21	UNS C10100, EN CuAg0.1, DIN 2.1203, SS 5010, UNE CUSi3Mn1, AFNOR Cu-C2, GOST M1f, UNI Cu-0F
	N4 Polimerler (sentetik veya yarı sentetik malzemeler)	N4.1 Termoplastik polimerler	0.70	ABS, Acryl, Duraplast, Elastomer, EP, Epoxid, FEP, Fluor, Gummi, Kautschuk, Latex, ME, MPF, PA, PAl, PC, PE, PEEK, PEI, PES, PET, PF, Phenolharze, PI, PMMA, Polyamide, Polyester, Polyolefine, Polysulfon, POM, PP, PPE, PPS, PS, PSU, PTFE, PU, PUR, PVDF, SAN, SI, Styrol, UF, Ureol
		N4.2 Isı ile sertleşen polimerler	0.27	Aramid, Epoxy, Fluoropolimer, Mehtacrylate, Melamine, Phenolic, Polyester, Polyimide, Polymethacrylimide, Polyurethane
		N4.3 Takviyeli polimerler veya kompozitler	0.29	CFK, GFK, GMT, Honeycomb, Kevlar, LFT, Organo, SMC
	N5 Grafit	N5.1	1.0	CGM-1, CM-00, GM-10, GM-11, GR030, GR030PI, GR060, GR060PI, GR125, MC-01, MC-01R0, MC-03, MC-03M, IG11, IG-15, IG-32, IG-43, IG-45, IG-70, ISEM-1, ISEM-2, ISEM-3, R8340, R8500X, Technograph 15, Technograph 30, ISO-63, EDM C-3, EDM1, EDM3, ISO-90, ISO-93, ISO-95, R8510, R8650, R8650

İŞ PARÇASI MALZEME GRUPLARI (WMG)



ISO grubu	Alt grup	WMG (İş Malzeme Grubu)	k_{ve}	Malzeme örnekleri (AISI, EN, DIN, ÇSN, GB, SS, STN, BS, UNE, AFNOR, ASTM, GOST, UNS, UNI, ...)
S Yüksek sıcaklık alaşımları (paslanmaz çelikten daha yüksek sıcaklık ve korozyon dayanımı olan süper alaşımlar)	S1 Titanyum veya titanyum alaşımları	S1.1 <200 HB sertliğinde titanyum veya titanyum alaşımları	1.94	UNS R50250 (Grade 1), EN Ti 99.6, DIN 3.7035, BS TA.2, UNE Ti-Po2, AFNOR T-40, GOST BT1-00, AISI R50250, 3.7025, T35, 2TA1, R50400, 3.7035, 2TAZ,
		S1.2 200 – 280 HB sertliğinde titanyum alaşımları	1.72	UNS R56404 (Grade 29), EN Ti2Cu, DIN 3.7124, BS TA.21, UNE Ti-P11, AFNOR T-U2, AISI TA6V, Ti-6Al-4V, Ti 10.2.3, Ti5553
		S1.3 280 – 360 HB sertliğinde titanyum alaşımları	1.44	UNS R54250 (Grade 38), EN TiAl6V4, DIN 3.7165, ÇSN TiAl6VELI, BS TA. 13, UNE Ti-P63, AFNOR T-A6V, GOST BT6, AISI TA6V, Ti-6Al-4V, Ti 10.2.3, Ti5553
	S2 Demir temelli yüksek sıcaklık alaşımları	S2.1 <200 HB sertliğinde demir temelli yüksek sıcaklık alaşımları	1.33	UNS N08801 (Incoloy 801), EN X8 NiCrAlTi31-21, DIN 1.4959, BS NA 15, AFNOR Z8NC33-21, AISI A-286, Discaloy, Haynes 556, Inconel 909, Greek Ascology
		S2.2 200 – 280 HB sertliğinde demir temelli yüksek sıcaklık alaşımları	1.17	UNS N19907, EN X6NiCrTiMoVB25-15-2, DIN 1.4980, SS 2570, BS HR52, AFNOR Z6NCTDV25.15B, GOST 36HXT10, AISI A-286, Discaloy, Haynes 556, Inconel 909, Greek Ascology
		S3.1 <280 HB sertliğinde nikel temelli yüksek sıcaklık alaşımları	1.00	UNS A09706 (Inconel 706), EN NiCr25FeAl, DIN 2.4856, BS HR 6, ÇSN Inconel 625, UNE F.3313, GB 1Cr16Ni35, AFNOR NC22FeDNB, GOST XH38BT, AISI Inconel 718, 706 Waspalloy, Udimet 720, Inconel 625
	S3 Nikel temelli yüksek sıcaklık alaşımları	S3.2 280 – 360 HB sertliğinde nikel temelli yüksek sıcaklık alaşımları	0.83	UNS N07001, EN NiCr20Co13Mo4Ti3Al, DIN 2.4654, BS HR 2, ÇSN Waspalloy, AFNOR NCKD 20ATV, GOST XH80T5K0, AISI Inconel 718, 706 Waspalloy, Udimet 720, Inconel 625
		S4 Kobalt temelli yüksek sıcaklık alaşımları	S4.1 <240 HB sertliğinde kobalt temelli yüksek sıcaklık alaşımları	0.78
	S4.2 240 – 320 HB sertliğinde kobalt temelli yüksek sıcaklık alaşımları		0.67	UNS R30016 (Stellite 6b), EN CoCr20W15Ni, DIN 2.4964, AFNOR KC 20 WN, GOST ЛК52, AISI Haynes 25, Stellite 21, 31

İŞ PARÇASI MALZEME GRUPLARI (WMG)

ISO grubu	Alt grup	WMG (İş Malzeme Grubu)	k_{vg}	Malzeme örnekleri (AISI, EN, DIN, ÇSN, GB, SS, STN, BS, UNE, AFNOR, ASTM, GOST, UNS, UNI, ...)
H Sertleştirilmiş malzemeler (sertliği > 45 HRC olan tüm mühendislik metalleri)	H1	Soğutulmuş dökme demir		
	H1.1	< 440 HB sertliğinde soğutulmuş dökme demir	1.52	UNS F45001, EN-GJS-1050-6, DIN 5.3406, SS 0512, BS Grade 2A
	H2	Sertleştirilmiş dökme demir		
	H2.1	< 55 HRC sertliğinde sertleştirilmiş dökme demir	0.90	UNS F45003, EN-GJS-1400-1, DIN 5.3405, SS 0457, BS Grade 3D
	H2.2	> 55 HRC sertliğinde sertleştirilmiş dökme demir	0.77	UNS F45003, EN-GX260NiCr4-2, DIN 0.9620, SS 0466, BS Grade S
	H3	< 55 HRC sertliğinde sertleştirilmiş çelik		
	H3.1	< 51 HRC sertliğinde sertleştirilmiş çelik	1.00	AISI 4135, EN 34CrMo4, DIN 1.7220, SS 2234, STN 415131, BS 198, UNE F.1250, GB 35CrMo, AFNOR 35CD4, GOST AC38XTM, UNI 35CrMo4KB
	H3.2	51 – 55 HRC sertliğinde sertleştirilmiş çelik	0.82	AISI 4135, EN 34CrMo4, DIN 1.7220, SS 2234, STN 415131, BS 198, UNE F.1250, GB 35CrMo, AFNOR 35CD4, GOST AC38XTM, UNI 35CrMo4KB
	H4	> 55 HRC sertliğinde sertleştirilmiş çelik		
	H4.1	55 – 59 HRC sertliğinde sertleştirilmiş çelik	0.64	UNS T31501, EN 100MnCrW4, DIN 1.2510, SS 2140, STN 419413, BS B01, UNE F.5220, GB 9CrWMn, AFNOR 90MnWCrV5, GOST 9XBТ, UNI 95MnWCr5KU
	H4.2	> 59 HRC sertliğinde sertleştirilmiş çelik	0.54	UNS T31501, EN 100MnCrW4, DIN 1.2510, SS 2140, STN 419413, BS B01, UNE F.5220, GB 9CrWMn, AFNOR 90MnWCrV5, GOST 9XBТ, UNI 95MnWCr5KU

DÜZELTME FAKTÖRLERİ

Belirli operasyon tipi için düzeltme faktörleri C_{VCO}

  	FF			F			M			R			HR		
	0.5			1.5			2.5			5.0			12.0		
	I	II	III	I	II	III	I	II	III	I	II	III	I	II	III
	0.05	0.08	0.10	0.10	0.15	0.20	0.20	0.30	0.40	0.40	0.60	0.80	0.80	1.00	1.30
İnce finiş işleme için talaş kırıcılar (FF, FF2...)	1.15	1.00	0.95	0.85	0.80	-	-	-	-	-	-	-	-	-	-
Finiş işleme için talaş kırıcılar (NF, SF...)	-	-	1.20	1.05	1.00	1.05	1.00	0.90	-	-	-	-	-	-	-
Orta talaş işleme için talaş kırıcılar (FM, M, NM, NMR, SM...)	-	-	-	-	-	1.15	1.10	1.00	0.95	0.85	-	-	-	-	-
Kaba talaş işleme için talaş kırıcılar (RM, NRM, NR, R...)	-	-	-	-	-	-	-	-	1.25	1.10	1.00	0.95	0.65	-	-
Ağır kaba işleme için talaş kırıcılar (HR, HR2, NR2, OR...) 45 dak. dayanım için	-	-	-	-	-	-	-	-	-	1.25	1.20	1.15	1.05	1.00	0.95

Gerekli dayanıklılık için düzeltme faktörleri C_{VCT}

	dakika	10	15	20	30	45	60
Genel işleme (finiş işlemenden kaba talaş işlemeye)		1.13	1.00	0.93	0.84	0.76	0.71
Ağır işleme (ağır kaba işleme)		-	-	-	1.10	1.00	0.93

Ek düzeltme faktörleri C_{VCA}

İşleme ortamı	C_{VCA}
İş malzemesinin durumu (dövme veya döküm nedeniyle bozuk yüzey)	0.70
İç çap tormalama	0.75
Dilimleme ve kanal açma (radyal)	0.88
Alına Kanal Açma	0.80
Darbeli Kesim	0.80
Stabil olmayan işleme şartları	0.85
Yaygın işleme şartları	1.00
Stabil işleme şartları	1.20

Ortaya çıkan düzeltilmiş kesme hızı v_{cC}

$$v_{cC} = v_c \cdot k_{vG} \cdot C_{VCO} \cdot C_{VCT} \cdot C_{VCA}$$

k_{vG} – kullanılan malzemenin katsayısı

v_c – katalog sayfasından başlangıç hızı

Kesici uç parçaları

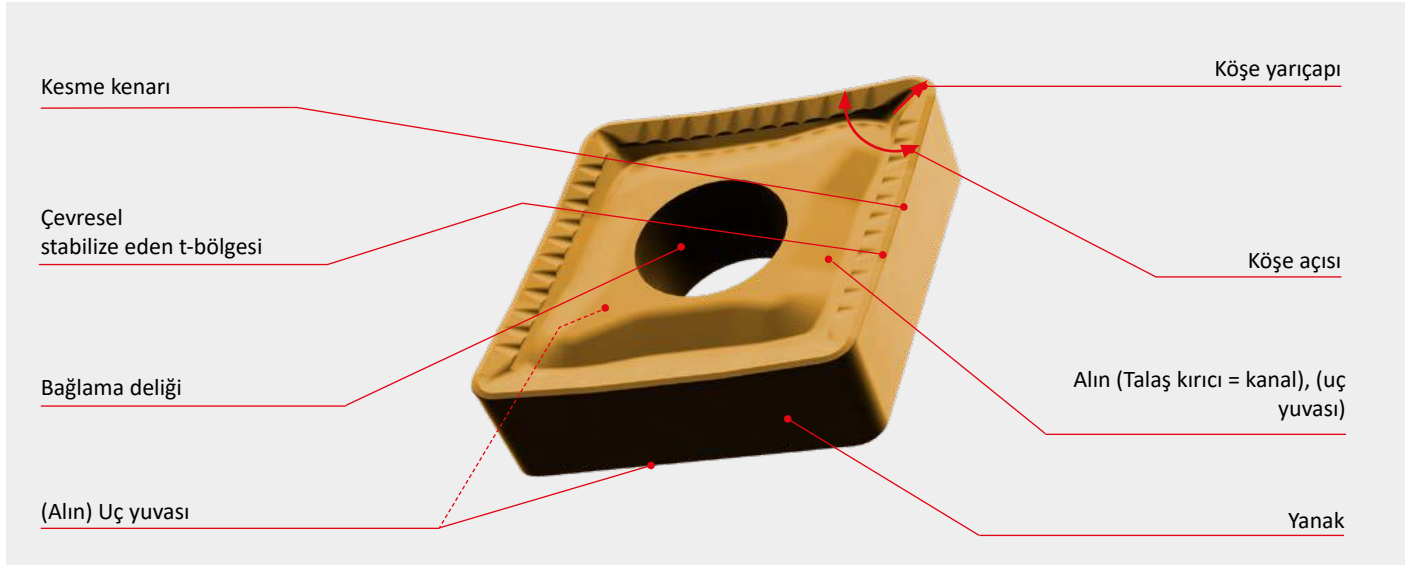

Köşe yarıçapı – çoğu durumda önerilen minimum kesme derinliğini ve ayrıca ilerlemeyle birlikte elde edilen pürüzlülüğü de belirler.

Kesici kenar alın ve yanak yüzeylerinin kesişimidir. Kenarın boyuna pürüzlülüğü, bir kesici uç değerlendirilirken ilk değerlendirme kriterlerinden biridir.

Kesici uç köşe açısı kullanılabilir kesme kenarı uzunluğu, darbeli kesimlere karşı direnç, kesme noktasından ısı dağılımı, vb. açılarından çok önemlidir.

Dikey stabilize eden t-bölgesi kesme kenarından sonra bulunan bir alandır. Genişliği çok değişkendir ve açısı da düzenli olarak değişir. Çoğu durumda, t-alanının genişliği, kesici ucun çalıştığı ayarlama açısı ile birlikte, minimum ilerlemeyi belirlemek için sınırlayıcı bir faktördür.

Talaş kırıcısı – t-bölgesiyle birlikte uygulama alanını belirler (dar kanallar - finiş işleme ve malzemeler, geniş kanallar - çoğunlukla kaba işleme işlemleri ve sert malzemeler).

Sıkma deliği – delik yoksa, kesici uç kesinlikle ISO C bağlama sistemi içindir. Delik silindirik şeklindeyse kesici uç ISO P, M, D + bağlama sistemleri için tasarlanmıştır (hemen tüm durumlarda yanak açısı 0°'dir. Delik trompet şeklindeyse ve yanak açısı pozitifse, kesici uç tek taraflıdır ve ISO S bağlama sistemi için tasarlanmıştır. Delik konikse ve kesici ucun her iki tarafında aynıysa, büyük olasılıkla teğetsel bir kesici uçtur (çift taraflı).

Uç yuvası – alın yüzeyi ile aynı boşaltma ile oluşturulmuşsa, ek parça çift taraflıdır, farklıysa ek tek taraflıdır. Değerlendirme, planlanan yük veya kesim türüne göre yapılmalıdır. (yarıçapın ve kesme kenarlarının boyutu ve mesafesi).

Takım tutucu parçaları

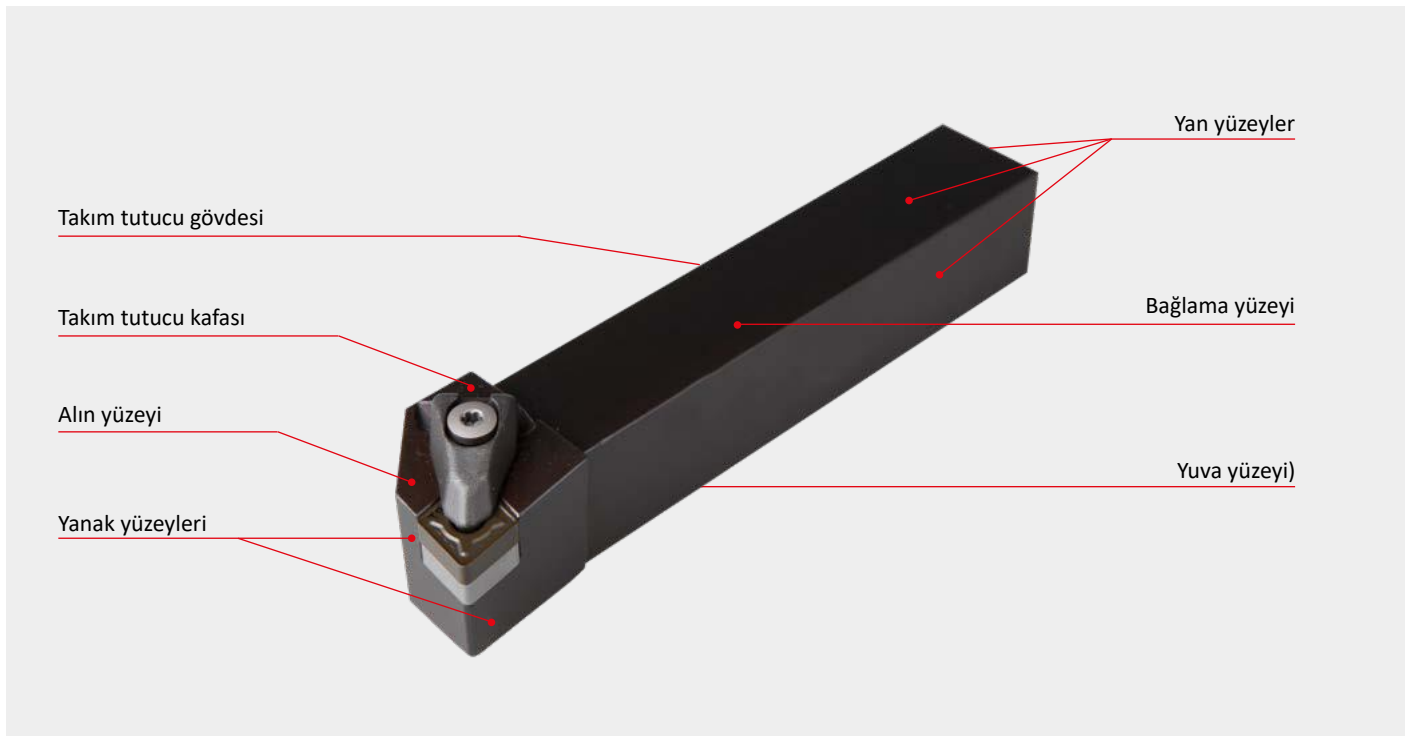

Torna takımı iki temel parçadan oluşur:

1) gövde bölümünde bulunanlar:

- yuva yüzeyi
- bağlama yüzeyi
- yan yüzeyler (ayrıca ayar vidalarıyla da sağlanabilir)

Not: Dış çap tornalama için, takım tutucu gövdesi genellikle kare bir kesittir (kare veya dikdörtgen). İç tornalama için tutucu gövdesinin kesiti daireseldir ve daha büyük kesitler için ayar yüzeyleri ile donatılmıştır. Ancak tutucu gövdesi, CAPTO (PSC) veya HSK gibi özel tipte bir shaftla da oluşturulabilir

2) kafa bölümünde bulunanlar:

- yüzey
- yanak yüzeyleri

Takım tutucu kafa ayrıca içine uçların yerleştirildiği bir bağlama sistemi içerir

Alından kenara (radyal uçlar için) veya yanak yüzeyinden itibaren (teğetsel uçlar için)

Not: kafa tipleri:

- düz – her iki yönde tornalama olanağı sunar
- kenar – sol ve sağ tasarım olarak ayrılır
- bükülmüş – sol ve sağ tasarım olarak ayrılır (karmaşık yüzeyleri tornalarken daha iyi erişim sağlar)

Torna takımlarının çalışma ve yapım açıları

Kesme kenarının iş parçasına ve onun geometrik şekline göre konumu ve yönü, kesme açısı özelliklerini belirler.

Kesme kenarındaki açılar iki koordinatlı bir sistemle belirlenir:

- tasarım
- çalışma

a) takım koordinat sistemi (sabit), tasarım, üretim ve kontrol sırasında kesici kenar geometrisini belirlemek için kullanılır. Bu sistemde

tanımlanan tüm açılara takım kesme açıları denir. Uç şekline göre ISO standartları tarafından tanımlanan tüm açılar bu gruba aittir.

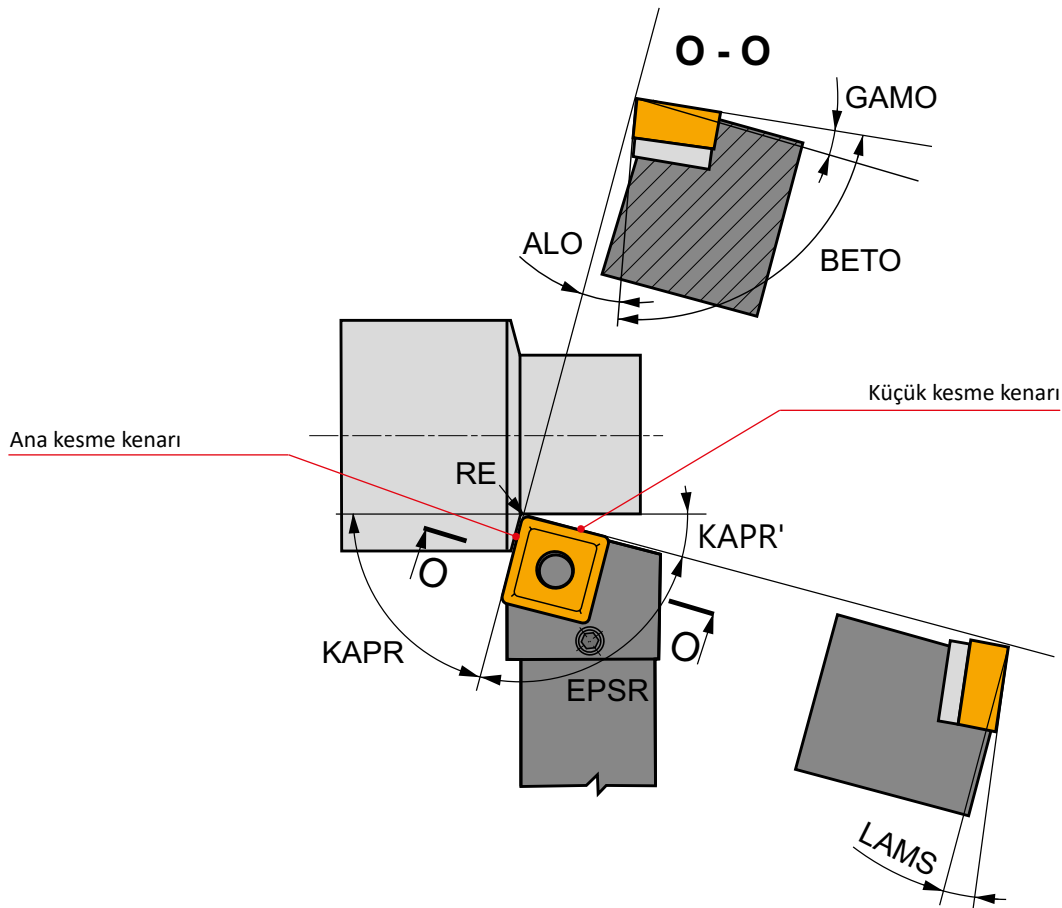

b) çalışma koordinat sistemi, işleme sırasında kesme kenarı geometrisini belirlemek için kullanılır. Bu açılara çalışma açıları denir ve bunlar, takım tutucuya kelepçelenen ucun konumuna bağlıdır. Örneğin kesici uç SNUN ile ilgili takım boşluk açısı $AN = 0^\circ$ ve eğim açısı $GAMP = 0^\circ$ şeklindedir, bununla birlikte kesici ucun takım tutucuya bağlantısında çalışma boşluğu açısı $ALO = 6^\circ$ ve çalışma eğim açısı $GAMO = -6^\circ$ değerindedir. Çalışma açıları, önceden şekillendirilmiş talaş kırıcıları olan takım açılarını etkiler. Ancak en önemlisi kesme işlemine ait çalışma açılarıdır.

Temel takım açıları, resimde temel takım düzleminde (takım tutucunun yatak yüzeyi ile birlikte) ve normal takım düzleminde (kesme kenarına çaprazlama - O-O kesimi) gösterilir.

Bizi ilgilendiren açılar şunlardır:

Eğim açısı GAMO – kesme işlemi önemli ölçüde etkiler. Boyutu, talaş oluşturma sırasındaki plastik deformasyonun ilerlemesini ve yoğunluğunu belirler; aynı zamanda kesme kuvvetlerinin değerini ve kesme kenarındaki termal gerilimi belirler. Eğim açıları geniş bir aralıktadır, frezeleme ve tornalama için değiştirilebilir kesici uçlara sahip kesici takımlarda $GAMO = +25^\circ$ ile -15° arasındadır. Pozitif bir eğim açısı, talaş oluşturma koşullarını iyileştirir, kesme kuvvetlerini azaltır ve kesme sıcaklığı seviyesini düşürür. Negatif bir kesim açısı kesme kenarının mukavemetini iyileştirir, ancak talaş oluşumu sırasında plastik deformasyonu ve dolayısıyla kesme kuvvetlerini ve sıcaklıkları da artırır.

Boşluk açısı ALO yanak ve işlenmiş yüzey arasındaki sürtünmenin değerini etkiler. **ALO** boşluk açısının artırılması bu sürtünmeyi ve dolayısıyla yanak aşınmasını azaltır.

Kama açısı BETO kesici ucun kamasının açısıdır. **BETO** açısının artırılması kesme kenarının gücünü artırır (şoka karşı direnç), ancak aynı zamanda kesme direncini de artırır.

Ana kesme kenarının eğim açısı LAMS – kesici kenar ile iş parçası arasındaki ilk temas noktasını belirler; bu nokta darbeli kesimler için önem taşır. **LAMS** is pozitif olursa temas noktası kesici ucun burnuna yakındır. **LAMS** açısının negatif olması ilk temas noktasını burundan uzaklaştırır ve kesme kenarının mekanik gerilime karşı direncini etkiler. Dahası, **LAMS** talaş tahliyesinin yönünü etkiler. **LAMS** negatif olursa, talaş boşaltma yönü işlenmiş yüzeye doğrudur. Ancak **LAMS** pozitif olursa, talaş boşaltma yönü işlenmiş yüzeyden uzağa doğru olur.

Ana kesme kenarının KAPR açısının ayarlanması esas olarak kesme kuvvetlerinin değerlerini ve talaşın kesit şeklini etkiler. **KAPR** açısı düşürüldüğünde belirli bir f ilerlemesi ve a_p kesme derinliğinde talaş kalınlığı düşer. Eğer $KAPR = 90^\circ$ olursa talaş kalınlığı $h = f$ ve talaş genişliği $b = a_p$ daha geniş olur. Azalan ayar açısıyla ilgili olarak, T-bölgesinin fonksiyon genişliği artar ve kesici ucun eğim açısı azalır.

Küçük kesme kenarının KAPR' ayar açısı ve **RE** köşe yarıçapı sonuçtaki yüzey kalitesini tanımlar.

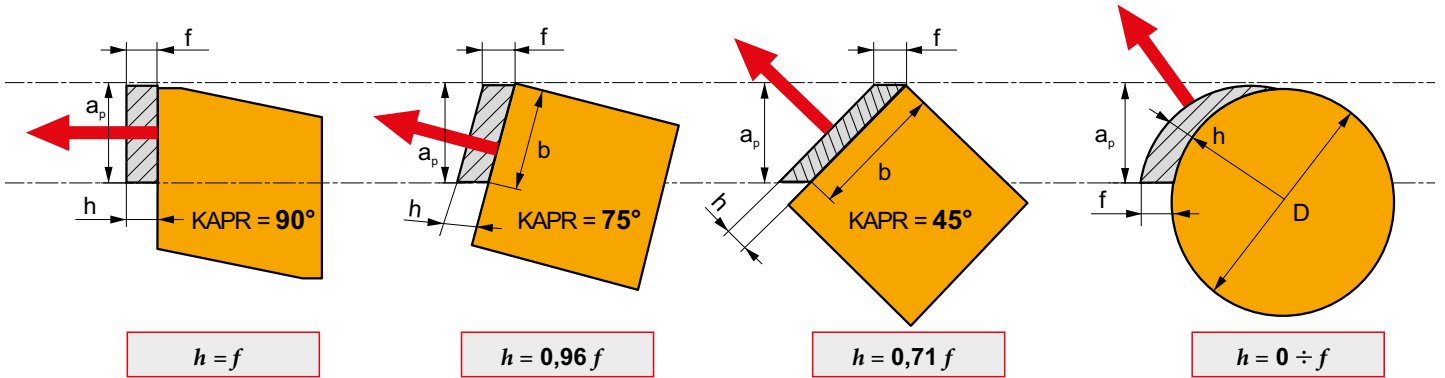

TEMEL TERİMLERİN TANIMI

Çalışma takımı geometrisinin etkisi

Parametre	Değişim	Yanak aşınması	Krater aşınma oluşumu	Plastik deformasyon eğilimi	Olumsuz çalışma koşullarına direnç	Yüzey	Kesme kuvvetleri	Titreşim eğilimi	Orta kesme sıcaklığı	Talaş oluşumu
Ana kesme kenarı açısı	90°'den küçük veya büyük	Biraz azalır	Biraz azalır	Biraz azalır	Biraz iyileşir	Etkisi kanıtlanmamıştır	Biraz artar	Artar	Azalır	Talaş daha ince ve daha geniştir (b/h değişir)
Küçük kesme kenarı açısı	Azalır	Biraz azalır	Etkisi kanıtlanmamıştır	Biraz artar	Çok az iyileşir	İyileşir (koşullu)	Biraz artar	Artar	Çok az yükselir	Önemsiz etki
Köşe açısı	Artar	Etkisi kanıtlanmamıştır	Etkisi kanıtlanmamıştır	Düşük	İyileşir	Etkisi kanıtlanmamıştır	Etkisi kanıtlanmamıştır (-)	Biraz artar	Çok az yükselir	Önemsiz etki
Köşe yarıçapı	Artar	Azalır (belirli bir düzeyde)	Azalır (belirli bir düzeyde)	Düşük	İyileşir	İyileşir (koşullu)	Artar (belirli bir düzeyde)	Artar	Biraz yükselir	Yumuşak oluşum (genellikle – talaş kırıcılığı göre)
Yanak açısı	Daha pozitif	Düşük	Etkisi kanıtlanmamıştır	Çok az Düşük	Biraz daha kötü	İyileşir (koşullu)	Biraz azalır	Biraz azalır	Hafifçe düşük	Etkisi kanıtlanmamıştır
Yüz açısı	Daha pozitif	Çok hafif azalır	Düşük	Biraz azalır	Biraz daha kötü	Etkisi kanıtlanmamıştır (+)	Biraz azalır	Düşük	Azalır	Talaş daha az sıkıştırılır, ancak kesme kenarına yaklaştırılır
Kesme kenarı açısı	Pozitif	Etkisi kanıtlanmamıştır	Biraz azalır	Biraz azalır	Biraz daha kötü	Etkisi kanıtlanmamıştır (+)	Biraz azalır	Biraz azalır	Hafifçe düşük	Talaş iş parçasından saptırır
T-bölgesi genişliği	Daha geniş	Biraz artar	Biraz artar	Biraz artar	Biraz iyileşir	Etkisi kanıtlanmamıştır (+)	Artar	Artar	Daha yüksek	Talaş daha fazla sıkıştırılır, ancak daha geniş bir yüzeye bastırır
T-bölgesi açısı (çalışma)	Pozitif	Çok hafif azalır	Biraz azalır	Biraz azalır	Biraz daha kötü	Etkisi kanıtlanmamıştır (+)	Düşük	Düşük	Hafifçe düşük	Talaş daha az sıkıştırılmıştır

Kesme kuvvetlerini neler ve nasıl etkiler?

Koşullar	Karbon çeliği (HB230)	Paslanmaz çelik (HB145)	Gri dökme demir (HB130)
Kesme hızı ve kesme kuvveti $f = 0.2$ mm/dev $a_p = 2$ mm KAPR 90° RE 0.4			
Kesme derinliği ve kesme kuvveti $V_c = 100$ m/dak $a_p = 0.2$ mm/dev KAPR 90° RE 0.4			
Kesme ilerlemesi ve kesme kuvveti $V_c = 100$ m/dak $a_p = 2$ mm KAPR 90° RE 0.4			
Köşe yarıçapı ve kesme kuvveti $V_c = 100$ m/dak $f = 0.2$ mm/dev $a_p = 1.2$ mm KAPR 90°			
Ana kesme kenarı açısı $V_c = 100$ m/dak $f = 0.2$ mm/dev $a_p = 2$ mm KAPR $45^\circ, 60^\circ, 75^\circ, 90^\circ$ (x eksenindeki değerler) RE 0.4			
Eğim açısı ve kesme kuvveti $V_c = 100$ m/dak $f = 0.2$ mm/dev $a_p = 2$ mm KAPR 90° RE 0.4			

Bağlama tekniğine göre takım tutucu seçimi

PRAMET TOOLS teklifi, takım tutucular, ayarlanabilir tutucular, taret kafaları ve boyuna dış çap, alın, kopya tornalama ve elbette içten tornalama için ayarlanabilen tutucular içerir. Takım tutucular, kesici uç bağlama sistemine göre aşağıdaki bölümde şematik olarak gösterilen altı gruba ayrılır.

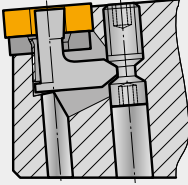

ISO P

Bu sistem, silindirik delikli negatif uçların hem talaş oluşturuçularla hem de bunlar olmadan bağlanmasını sağlar. Uç sıkıştırması, vidanın sıkılmasıyla ucu tutucu yatağına doğru bastıran bir açılı kol tarafından sağlanır. Bu bağlama sistemine sahip takım tutucular, kesici ucun güvenilir ve tam olarak sıkıştırılmasını sağlar. Dış tornalama işlemlerinde, yani hem finiş işleme hem de kaba talaş işlemede en iyi ve aynı zamanda en yaygın kullanımı sunar. Alternatif olarak bu tip bir bağlama, daha büyük çaplı deliklerin içten tornalanması için tasarlanan tutucularda da kullanılabilir.

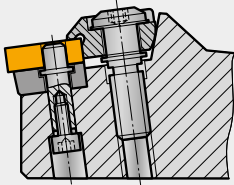

ISO M

Bu sistem, ISO P sistemiyle aynı tipteki kesici uçların bağlanması için kullanılır. Bu durumda uç, bir kelepçe ile bastırılarak güçlü bir pime yerleştirilir ve bu pim aynı zamanda ucun üst kısmını da sabitler. Bu bağlama sistemi genelde daha çok dinamik yük taşıdığı düşünülen tutucular için uygundur. Bu tutucular neredeyse sadece dış tornalama için kullanılır.

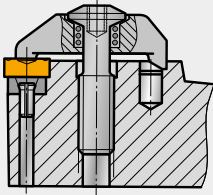

ISO C

Bu sistem hem negatif hem de pozitif, yani talaş oluşturuçuları olan (önceden preslenmiş, taşlanmış ve yandan preslenmiş) ve olmayan deliksiz uçların bağlanmasında kullanılır. Uç, takım tutucu yatağına vidalı bir kelepçe ile sabitlenir ve altında hala bazı uç tiplerinde yandan preslenmiş bir talaş oluşturuçusu bulunur. Bu bağlama sistemine sahip tutucular hem dış hem de iç yüzey işleme için kullanılır. Günümüzde C tipi bağlama sistemi önemini yitirmiş durumdadır. Özellikle iç tornalama takımlarında daha avantajlı olan S sistemi ile değiştirilir.

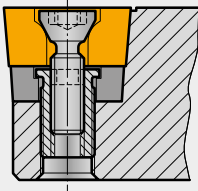

ISO S

Bu bağlama sistemi esas olarak hem dış hem de iç tornalama (delme) için tasarlanmış küçük kesitli takımlarda kullanılır. Bu durumda uç koni deliğinden geçen özel bir vida bağlamayı sağlar. Uç, bu vidanın sıkılmasıyla takım yatağına sabitlenir. Talaş akışının önünde herhangi bir engel olmadığı için bu çözüm özellikle kullanışlıdır.

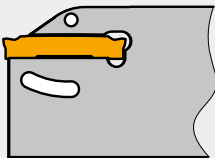

ISO X

Bu işaret, özel bağlama sistemine sahip olarak adlandırılan (yani, takım üreticilerine ve tedarikçilerine göre farklılıklar gösteren) takımları tanımlar. Bizim durumumuzda bu işaret altında, kendiliğinden kilitlenen yatağı kesici uç sıkıştırmak için kesme direncini kullanan takım tutucularını belirtiyoruz. Bu kenetleme sistemi, ayırma ve yuva oluşturma için tasarlanmış takımlarda kullanılır.

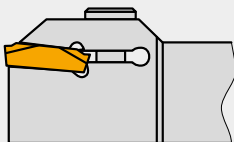

ISO G

Bu bağlama sistemi, yuva tornalama ve kopya tornalama takımlarında (CTP sistemi) kullanılır. Uç, üstten bir bağlama ile tutucu yatağına itilir. Tutucuda, bağlamada ve ayrıca ucun içinde bulunan temas yüzeyi, ucun yerinin kesme hızı ilerleme bileşeni tarafından değiştirilmesini önlemek üzere şekillendirilmiştir.

KESİCİ TAKIM SEÇİMİ

Kare kesme takımına referansla

Dış kesme aletleri (kare kesitli)

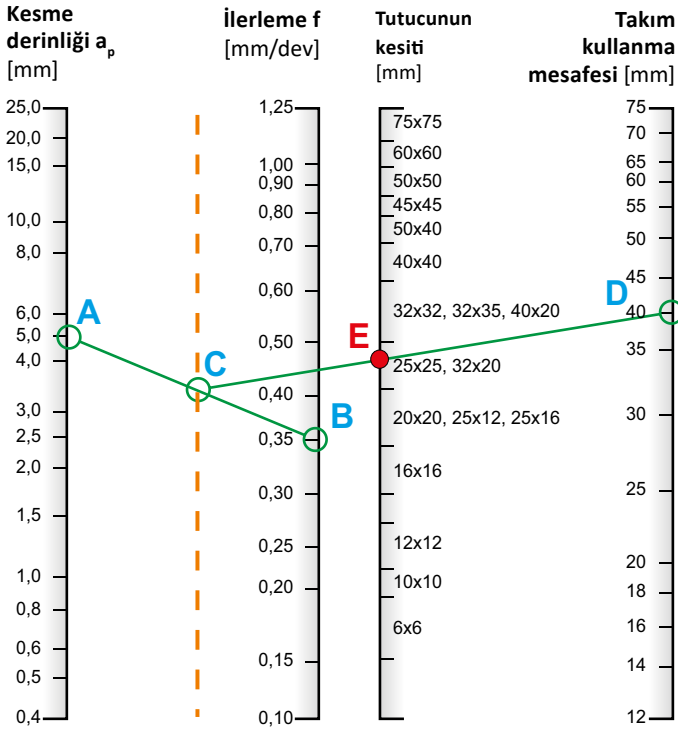

Maalesef, iç tornalamadaki durum talaş nedeniyle karmaşık olduğundan, iç kesme takımının çapını seçmek için size benzer bir şema sunamıyoruz. Uzun kullanma mesafesi nedeniyle, mümkün olduğu kadar büyük çapa sahip bir tutucu seçilmelidir, ancak tutucunun çapı işlenecek deliğin çapına yakınsa talaş tahliyesi ile ilgili sorunlar ortaya çıkabilir. Talaş genellikle delik duvarı ile tutucu gövde arasına girer ve oluşan yüzeye zarar verir.

Genel olarak, çelik gövdeli takımlar kullanıyorsanız, kullanma mesafesi $4xD$ 'yi geçmemelidir ve karbür veya ağır metal gövdeli takımlarınız varsa maksimum kullanma mesafesi $6xD$ olmalıdır. Her iki tür alet için de aleti bağlama kısmının en az $3xD$ olması gerektiğini unutmayın.

Bağlama seçenekleri ve işlem sınırlamaları ile ilgili olarak mümkün olan maksimum kesiti kullanın.

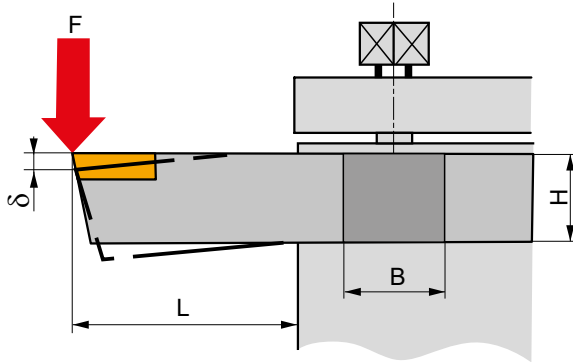

Bükülme gerilimi

$$\sigma = \frac{6 \cdot F \cdot L}{B \cdot H^2} \text{ (MPa)}$$

Takım tutucu sapması

$$\delta = \frac{4 \cdot F \cdot L^3}{E \cdot B \cdot H^3} \text{ (mm)}$$

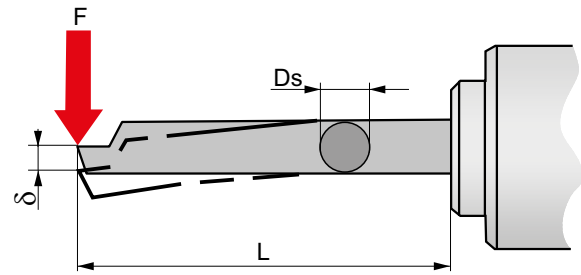

Bükülme gerilimi

$$\sigma = \frac{32 \cdot F \cdot L}{\pi \cdot D_s^3} \text{ (MPa)}$$

Takım tutucu sapması







$$\delta = \frac{64 \cdot F \cdot L^3}{3 \cdot \pi \cdot E \cdot D_s^3} \text{ (mm)}$$

σ	Gövdedeki bükülme gerilimi [MPa]
F	Kesme kuvveti [N]
L	Takım kullanma mesafesi [mm]
B	Gövde genişliği [mm]
H	Gövde yüksekliği [mm]
D_s	Gövde çapı [mm]
E	Gövde malzemesi elastik modülü [MPa]

Malzeme	MPa [N/mm ²]	[kgf/mm ²]
Çelik	210.000	21.000
Sinterlenmiş karbür	560.000 – 620.00	56.000 – 62.00

Kullanma mesafesindeki %50 azalma, sapmayı %88 düşürür. Kesitteki 1/3 artış, bükülmeyi %68 azaltır.

Kesici ucun şeklini ve boyutunu seçme

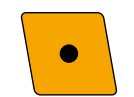
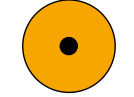
Tercih önceliği	Kesici uç şekli	Burun açısı	Kesici uç boyutu		Maksimum kesme kenarı uzunluğu Lmax		Kaba Talaş İşleme	Hafif kaba işleme	Finiş işleme	Profil tornalama	Alın tornalama	Çok yönlü uygulamalar	Titreşim eğilimi	Sert malzeme	Darbeli Kesim	
			ISO	ANSI	(mm)	(")										
Profil oluşturma ve daha az titreşim için kesme kenarının erişilebilirliğini artırma.		V	35°	11	2	0.25L	2.80	.110"								
				13			3.30	.130"								
			16	3	4.20		.165"									
Kesme kenarının mukavemetini ve darbeli kesime uygunluğunu artırma.		D	55°	07	2	0.25L	2.00	.078"								
				11	3		2.90	.114"								
				15	4	3.90	.153"									
		T	60°	11	2	0.33L	3.60	.141"								
				16	3		5.50	.216"								
				22	4		7.30	.287"								
				27	5	9.10	.358"									
		W	80°	06	3	0.50L	3.30	.129"								
				08	4		4.40	.173"								
		C	80°	06	2	0.66L	4.20	.165"								
				09	3		6.40	.251"								
				12	4		8.50	.334"								
				16	5		10.60	.417"								
				19	6		12.70	.500"								
				25	8	16.50	.649"									
		S	90°	09	3	0.66L	6.30	.248"								
				12	4		8.40	.330"								
				15	5		10.40	.409"								
				19	6		12.60	.496"								
				25	8	16.80	.661"									
		C	100°	12	4	0.66L	8.50	.334"								
				19	6		12.70	.500"								
				25	8		16.50	.649"								
		R		06		0.40D	2.40	.094"								
				08			3.20	.125"								
				10			4.00	.157"								
				12			4.80	.188"								
				15			6.00	.236"								
				16			6.40	.251"								
				19			7.60	.299"								
				20			8.00	.315"								
				25			10.00	.393"								
							32		12.80	.503"						

KESİCİ UÇ SEÇİMİ

Optimum kesici uç kalınlığının seçilmesi

Uygulamaya dayalı olarak, bu işlemi sadece darbeli kesim için ve maksimum kesici uç yükü ile gerçekleştirmenizi öneririz.

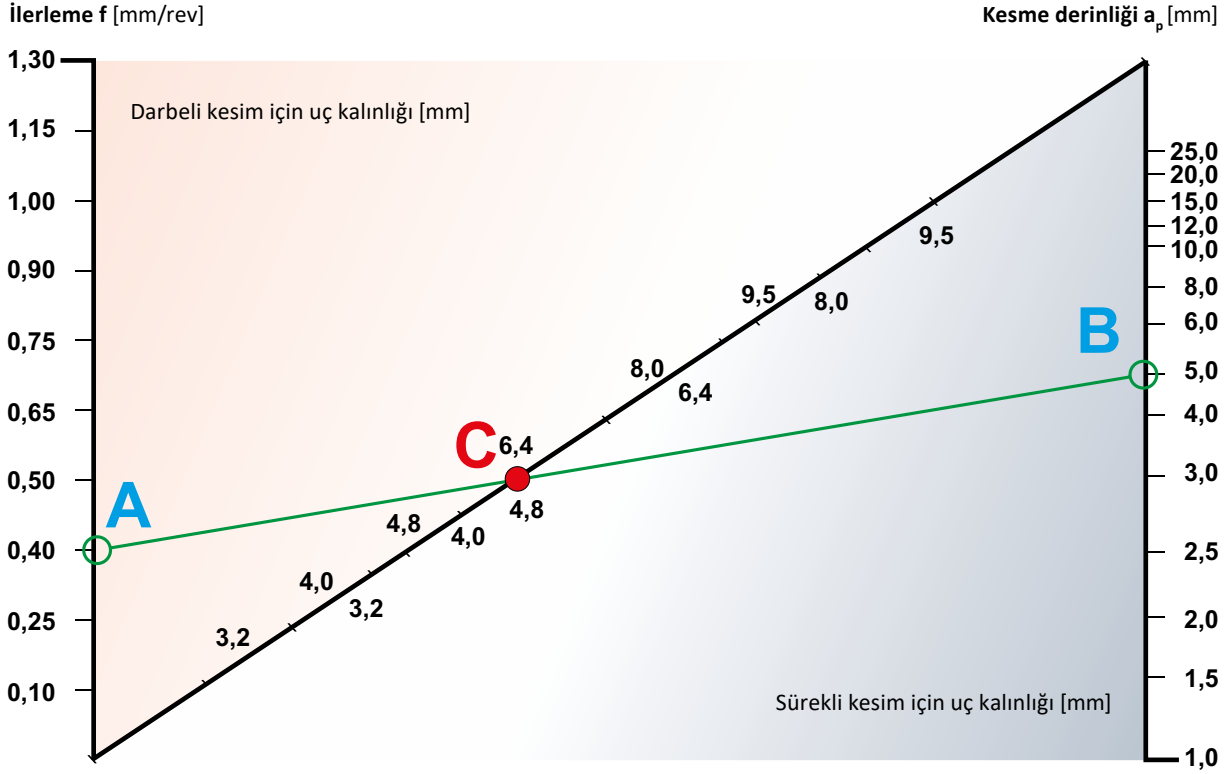

Kesici uç köşe yarıçapının seçilmesi

Uygulamaya dayalı olarak, bu işlemi sadece darbeli kesim için ve maksimum kesici uç yükü ile gerçekleştirmenizi öneririz.

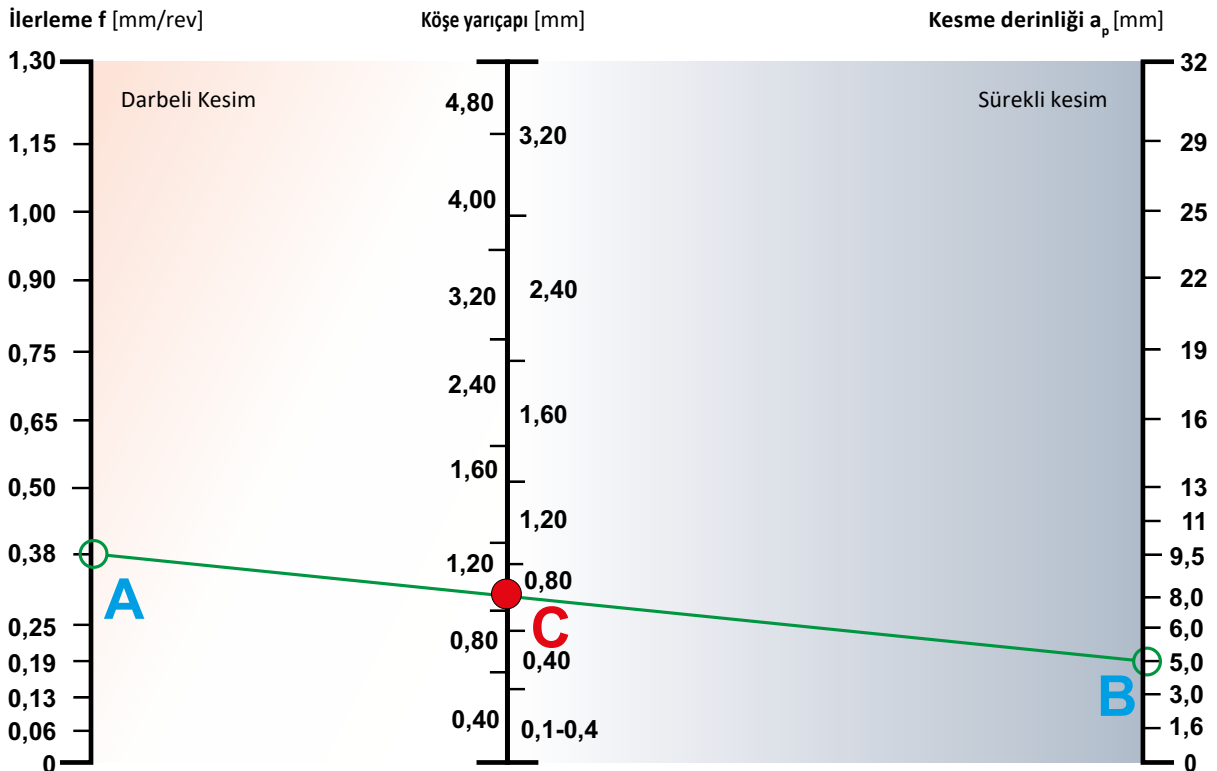

İlerleme ve küçük kesme kenarı açısı ile birlikte kesici uç yarıçapı, işlenmiş yüzeyin pürüzlülüğünü belirleyen ana kriterlerden biridir. Açıkta ki, kesme ortamı da dahil olmak üzere işlenen malzemenin özellikleri ve tipi önemli bir etkiye sahiptir.

Bu bölümün başında, mühendislik uygulamalarında en sık belirtilen ana pürüzlülük parametreleri açıklanmıştır.

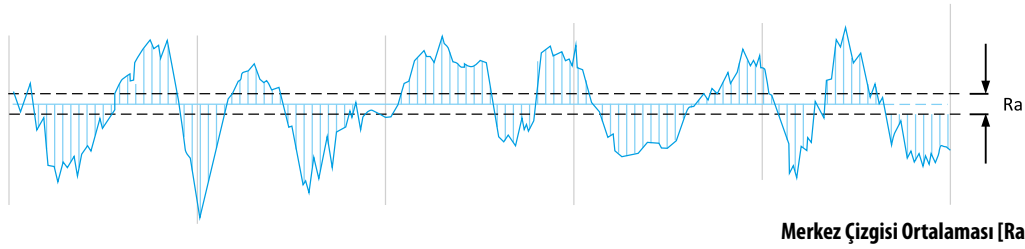

Ra – Ortalama pürüzlülük

Ra, Aritmetik Ortalama (AA) veya Merkez Çizgi Ortalaması (CLA) olarak da bilinir. Pürüzlülük profili ile ortalama çizgisi arasındaki alandaki ortalama pürüzlülüktür. Grafik olarak Ra, pürüzlülük profili ile merkez çizgisi arasındaki alandır ve değerlendirme uzunluğuna bölünür. Değerlendirme uzunluğu normalde her numune uzunluğunun bir kesme uzunluğuna eşit olduğu beş adet numunenin uzunluğudur. Grafikte gösterilmiştir.

Ra, açık arayla en yaygın kullanılan Yüzey Kalitesi parametresidir ve hiçbir parametre belirtme çizgisi olmadığında bile parçaları ölçmek için iyi bir başlangıç noktasıdır (yüzey kalitesi gereklidir). Bununla birlikte, her ne kadar yaygın olsa da, Ra, bir yüzeyin pürüzlülüğünü tamamen karakterize etmek için yeterli değildir. Uygulamaya bağlı olarak aynı pürüzlülüğe sahip yüzeyler oldukça farklı performans gösterebilir. Aynı yüzey pürüzlülüğüne 3 farklı şekilde bakalım:

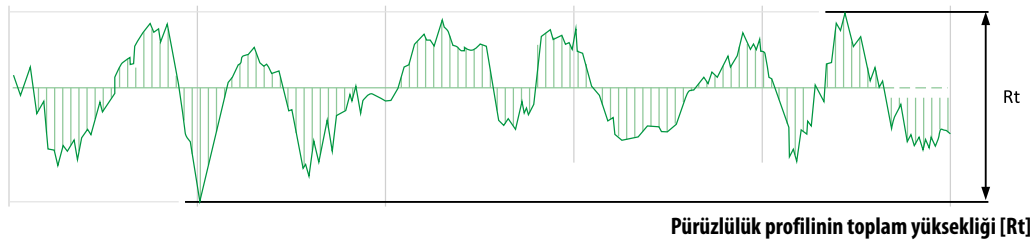

Rt – Toplam pürüzlülük profili yüksekliği

En alttaki grafikte de görüldüğü üzere, değerlendirme uzunluğu içindeki en yüksek tepenin yüksekliği ile en derin vadinin derinliği arasındaki farktır.

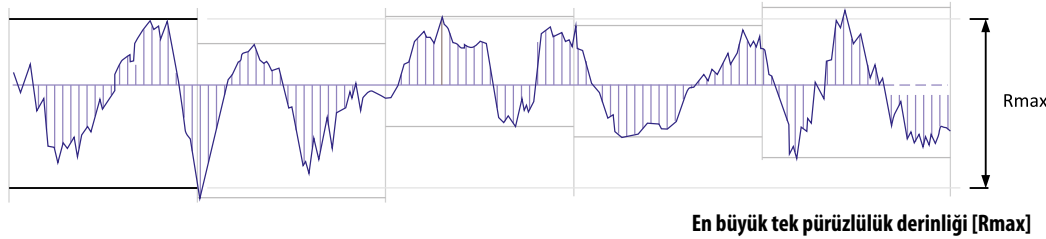

Rmax – Toplam kesme uzunluğundaki en yüksek tepeden en alçak vadiye kadar olan maksimum mesafedir

Ya da, diğer bir ifadeyle Rmax, numune uzunluklarından birinde ölçülen en büyük tek pürüzlülük derinliğidir. Rmax, çizikler ve çapaklar gibi anormalliklere karşı özellikle hassastır; bu anormallikler ortalamalara dayanan Ra gibi ölçümlerde ortaya çıkmayabilir.

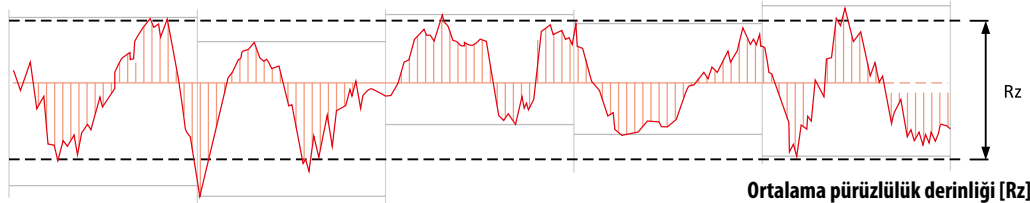

Rz – Ortalama pürüzlülük derinliği

Rz, Avrupa'da ve özellikle Almanya'da genellikle Ra'ya tercih edilir. Rz, Ra gibi merkez hattından ölçüm yapmak yerine beş örnekleme uzunluğu içindeki en büyük 5 tepe - vadi farkının ortalamasını ölçer. Ra birkaç aşırı için nispeten duyarlı olsa da, Rz aşırıları ölçmek üzere tasarlandığından oldukça duyarlıdır.

Yüzey Pürüzlülüğü Kaliteleri: "N" Sayıları

N sayıları, yüzey pürüzlülüğünü açıklamak için teknik çizimlerde yaygın olarak kullanılır. Geçmişte üçgenler kullanılmıştır, ancak bunlar doğru yüzey kalitesini açıklayacak kadar somut değildir.

Üçgen Sembolüyle İlişki

Aritmetik Ortalama Pürüzlülük Ra [μ m]	Maks. Yükseklik Pürüzlülük Rz [μ m]	On Nokta Ortalama Pürüzlülük RzJIS [μ m]	Pürüzlülük Kalite	Not: (Üçgen ile ilişki)
0.025	0.1	0.1	N1	VVV
0.05	0.2	0.2	N2	
0.1	0.4	0.4	N3	
0.2	0.8	0.8	N4	
0.4	1.6	1.6	N5	VV
0.8	3.2	3.2	N6	
1.6	6.3	6.3	N7	
3.2	12.5	12.5	N8	V
6.3	25	25	N9	
12.5	50	50	N10	V
25	100	100	N11	

Not: Finiş işleme sembolü (Üçgen ve dalga ~), 1994 Revizyonunda JIS standardından kaldırılmıştır.

Piyasada, herhangi bir elektronik ekipmanınız yoksa yüzey kaplamasını görsel olarak kontrol edebileceğiniz "RugoTest" ürününü bulabilirsiniz. Bunun sadece bir kılavuz olduğunu ve ölçüm olmadığını unutmayın



Aşağıdaki tablolarda belirtilen R_z ve R_a pürüzlülük değerleri büyük boyutlu küçük kesme kenarı açısına $KAPR$ ' sahip kesici uçlarla yapılan tornalama için geçerlidir; bunlar T..., S..., D..., K..., V... temel şekillerindeki uçlardır. Tornalama yaparken C ..., W ... şeklindeki uçlar kullanıldığında ve özellikle de SİLİCİ geometrisine sahip olan $KAPR = 90^\circ - 95^\circ$ ayarlama açılı takımlarda genellikle tablodakilere kıyasla

daha düşük R_a pürüzlülük değerleri elde edilir. Bunun nedeni küçük kesme kenarına ait $KAPR$ ' açısının düşük değeridir. Bu durumda pürüzlü alanlar kesilir ve teorik maksimum pürüzlü alanlar, aşağıdaki resim karşılaştırmadan da anlaşılacağı üzere $R_{max3} < R_{max2} < R_{max1}$ olarak düşürülür.

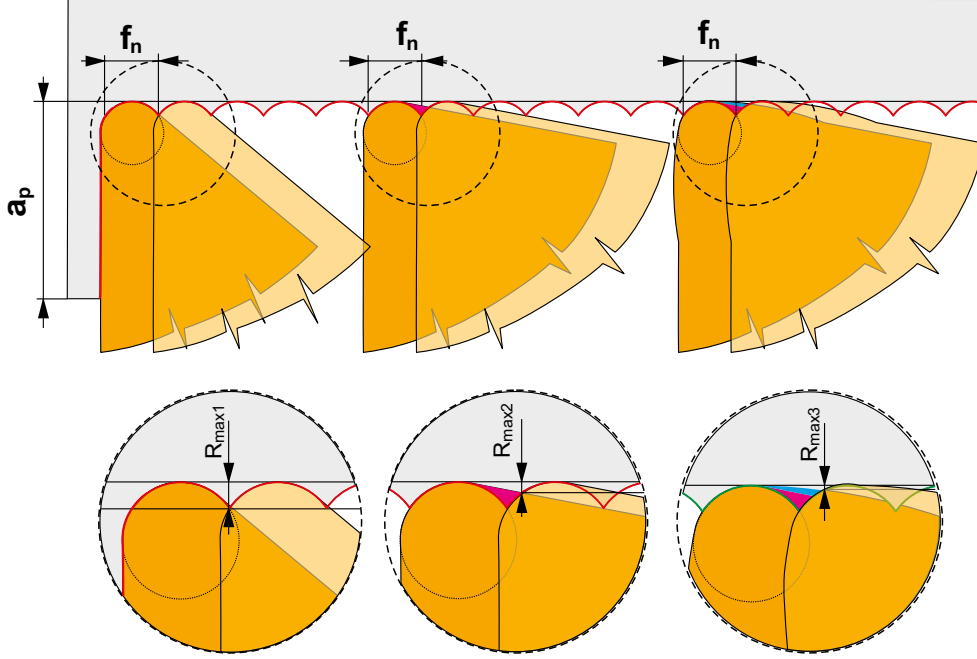

R_{max} Tornalama yüzey kalitesi

$$R_{max} = \frac{f^2}{8 \cdot RE} \cdot 1000$$

f →	RE Radyus																		
	0.1	0.2	0.4	0.5	0.8	1.0	1.2	1.5	1.6	2.0	2.4	2.5	3.0	3.2	3.5	4.0	5.0	6.0	8.0
	Yüzey R_{max} (µm)																		
0.05	3.13	1.56	0.78	0.63	0.39	0.31	0.26	0.21	0.20	0.16	0.13	0.13	0.10	0.10	0.09	0.08	0.06	0.05	0.04
0.07	6.1	3.06	1.53	1.23	0.77	0.61	0.51	0.41	0.38	0.31	0.26	0.25	0.20	0.19	0.18	0.15	0.12	0.10	0.08
0.08	8.0	4.0	2.00	1.60	1.00	0.80	0.67	0.53	0.50	0.40	0.33	0.32	0.27	0.25	0.23	0.20	0.16	0.13	0.10
0.10		6.3	3.13	2.50	1.56	1.25	1.04	0.83	0.78	0.63	0.52	0.50	0.42	0.39	0.36	0.31	0.25	0.21	0.16
0.12		9.0	4.50	3.60	2.25	1.80	1.50	1.20	1.13	0.90	0.75	0.72	0.60	0.56	0.51	0.45	0.36	0.30	0.23
0.15		14	7.0	5.6	3.52	2.81	2.34	1.88	1.76	1.41	1.17	1.13	0.94	0.88	0.80	0.70	0.56	0.47	0.35
0.16		16	8.0	6.4	4.00	3.20	2.67	2.13	2.00	1.60	1.33	1.28	1.07	1.00	0.91	0.80	0.64	0.53	0.40
0.18		20	10.1	8.1	5.1	4.05	3.38	2.70	2.53	2.03	1.69	1.62	1.35	1.27	1.16	1.01	0.81	0.68	0.51
0.20			13	10.0	6.3	5.0	4.17	3.33	3.13	2.50	2.08	2.00	1.67	1.56	1.43	1.25	1.00	0.83	0.63
0.22			15	12.1	7.6	6.1	5.0	4.03	3.78	3.03	2.52	2.42	2.02	1.89	1.73	1.51	1.21	1.01	0.76
0.25			20	16	9.8	7.8	6.5	5.2	4.88	3.91	3.26	3.13	2.60	2.44	2.23	1.95	1.56	1.30	0.98
0.27			23	18	11.4	9.1	7.6	6.1	5.7	4.56	3.80	3.65	3.04	2.85	2.60	2.28	1.82	1.52	1.14
0.30			28	23	14	11.3	9.4	7.5	7.0	5.6	4.69	4.50	3.75	3.52	3.21	2.81	2.25	1.88	1.41
0.32			32	26	16	13	10.7	8.5	8.0	6.4	5.3	5.1	4.27	4.00	3.66	3.20	2.56	2.13	1.60
0.35			38	31	19	15	13	10.2	9.6	7.7	6.4	6.1	5.1	4.79	4.38	3.83	3.06	2.55	1.91
0.37			43	34	21	17	14	11.4	10.7	8.6	7.1	6.8	5.7	5.3	4.89	4.28	3.42	2.85	2.14
0.40				40	25	20	17	13	13	10.0	8.3	8.0	6.7	6.3	5.7	5.0	4.00	3.33	2.50
0.45				51	32	25	21	17	16	13	10.5	10.1	8.4	7.9	7.2	6.3	5.1	4.22	3.16
0.50					39	31	26	21	20	16	13	13	10.4	9.8	8.9	7.8	6.3	5.2	3.91
0.55					47	38	32	25	24	19	16	15	13	11.8	10.8	9.5	7.6	6.3	4.73
0.60					56	45	38	30	28	23	19	18	15	14	13	11.3	9.0	7.5	5.6
0.65					66	53	44	35	33	26	22	21	18	17	15	13	10.6	8.8	6.6
0.70					77	61	51	41	38	31	26	25	20	19	18	15	12.3	10.2	7.7
0.75					88	70	59	47	44	35	29	28	23	22	20	18	14	11.7	8.8
0.80						80	67	53	50	40	33	32	27	25	23	20	16	13	10.0
0.85						90	75	60	56	45	38	36	30	28	26	23	18	15	11.3
0.90						101	84	68	63	51	42	41	34	32	29	25	20	17	13
0.95						113	94	75	71	56	47	45	38	35	32	28	23	19	14
1.00							104	83	78	63	52	50	42	39	36	31	25	21	16
1.20								120	113	90	75	72	60	56	51	45	36	30	23
1.30								141	132	106	88	85	70	66	60	53	42	35	26
1.40								163	153	123	102	98	82	77	70	61	49	41	31
1.50									176	141	117	113	94	88	80	70	56	47	35
1.60										160	133	128	107	100	91	80	64	53	40
1.70										181	151	145	120	113	103	90	72	60	45
1.80										203	169	162	135	127	116	101	81	68	51
1.90										226	188	181	150	141	129	113	90	75	56
2.00											208	200	167	156	143	125	100	83	63
2.20											252	242	202	189	173	151	121	101	76
2.50													260	244	223	195	156	130	98

Tornalama yüzey kalitesi R_a

$$R_a = 43,9 \frac{f^{1,88}}{RE^{0,97}}$$

f ⇒	RE Radyus																		
	0.1	0.2	0.4	0.5	0.8	1.0	1.2	1.5	1.6	2.0	2.4	2.5	3.0	3.2	3.5	4.0	5.0	6.0	8.0
	Yüzey R_a (µm)																		
0.05	1.47	0.75	0.38	0.31	0.20	0.16	0.13	0.11	0.10	0.08	0.07	0.06	0.05	0.05	0.05	0.04	0.03	0.03	0.02
0.07	2.76	1.41	0.72	0.58	0.37	0.30	0.25	0.20	0.19	0.15	0.13	0.12	0.10	0.10	0.09	0.08	0.06	0.05	0.04
0.08	3.55	1.81	0.93	0.75	0.47	0.38	0.32	0.26	0.24	0.19	0.16	0.16	0.13	0.12	0.11	0.10	0.08	0.07	0.05
0.10		2.76	1.41	1.13	0.72	0.58	0.48	0.39	0.37	0.30	0.25	0.24	0.20	0.19	0.17	0.15	0.12	0.10	0.08
0.12		3.88	1.98	1.60	1.01	0.82	0.68	0.55	0.52	0.42	0.35	0.34	0.28	0.26	0.24	0.21	0.17	0.14	0.11
0.15		5.9	3.02	2.43	1.54	1.24	1.04	0.84	0.79	0.63	0.53	0.51	0.43	0.40	0.37	0.32	0.26	0.22	0.17
0.16		6.7	3.41	2.74	1.74	1.40	1.17	0.94	0.89	0.71	0.60	0.58	0.48	0.45	0.42	0.36	0.29	0.25	0.19
0.18		8.3	4.25	3.42	2.17	1.75	1.46	1.18	1.11	0.89	0.75	0.72	0.60	0.57	0.52	0.46	0.37	0.31	0.23
0.20			5.2	4.17	2.64	2.13	1.78	1.44	1.35	1.09	0.91	0.88	0.73	0.69	0.63	0.56	0.45	0.37	0.28
0.22			6.2	4.99	3.16	2.55	2.14	1.72	1.62	1.30	1.09	1.05	0.88	0.82	0.76	0.66	0.53	0.45	0.34
0.25			7.9	6.3	4.02	3.24	2.72	2.19	2.05	1.65	1.39	1.33	1.12	1.05	0.96	0.84	0.68	0.57	0.43
0.27			9.1	7.3	4.65	3.74	3.14	2.53	2.37	1.91	1.60	1.54	1.29	1.21	1.11	0.98	0.79	0.66	0.50
0.30			11.1	8.9	5.7	4.57	3.83	3.08	2.89	2.33	1.95	1.88	1.57	1.48	1.35	1.19	0.96	0.80	0.61
0.32			13	10.1	6.4	5.2	4.32	3.48	3.27	2.63	2.20	2.12	1.78	1.67	1.53	1.34	1.08	0.91	0.69
0.35			15	11.9	7.6	6.1	5.1	4.12	3.87	3.11	2.61	2.51	2.10	1.97	1.81	1.59	1.28	1.07	0.81
0.37			16	13	8.4	6.8	5.7	4.57	4.29	3.46	2.90	2.78	2.33	2.19	2.01	1.76	1.42	1.19	0.90
0.40				15	9.7	7.8	6.6	5.3	4.97	4.00	3.35	3.22	2.70	2.54	2.33	2.04	1.65	1.38	1.04
0.45				19	12.1	9.8	8.2	6.6	6.2	4.99	4.19	4.02	3.37	3.17	2.90	2.55	2.05	1.72	1.30
0.50					15	11.9	10.0	8.0	7.6	6.1	5.1	4.90	4.11	3.86	3.54	3.11	2.50	2.10	1.59
0.55					18	14	12.0	9.6	9.0	7.3	6.1	5.9	4.92	4.62	4.23	3.72	2.99	2.51	1.90
0.60					21	17	14	11.3	10.7	8.6	7.2	6.9	5.8	5.4	4.98	4.38	3.53	2.96	2.24
0.65					24	20	16	13	12.4	10.0	8.4	8.0	6.7	6.3	5.8	5.1	4.10	3.44	2.60
0.70					28	22	19	15	14	11.5	9.6	9.2	7.7	7.3	6.7	5.9	4.71	3.95	2.99
0.75					32	26	21	17	16	13	10.9	10.5	8.8	8.3	7.6	6.7	5.4	4.50	3.40
0.80						29	24	19	18	15	12.3	11.9	9.9	9.3	8.6	7.5	6.1	5.1	3.84
0.85						32	27	22	21	17	14	13	11.1	10.5	9.6	8.4	6.8	5.7	4.30
0.90						36	30	24	23	18	15	15	12.4	11.7	10.7	9.4	7.6	6.3	4.79
0.95						40	33	27	25	20	17	16	14	13	11.8	10.4	8.4	7.0	5.3
1.00							37	30	28	22	19	18	15	14	13	11.4	9.2	7.7	5.8
1.20								42	39	32	26	25	21	20	18	16	13	10.9	8.2
1.30								49	46	37	31	30	25	23	21	19	15	13	9.6
1.40								56	52	42	35	34	28	27	25	22	17	15	11.0
1.50									60	48	40	39	32	30	28	25	20	17	13
1.60										54	45	44	37	34	32	28	22	19	14
1.70										61	51	49	41	39	35	31	25	21	16
1.80										68	57	54	46	43	39	35	28	23	18
1.90										75	63	60	51	47	44	38	31	26	20
2.00											69	66	56	52	48	42	34	28	21
2.20											83	79	67	63	57	50	41	34	26
2.50													85	80	73	64	52	43	33



Talaş oluşumunun sertliği - uygun talaş oluşumuna büyük dikkat gösterilmelidir (talaş, kesme noktasından kolayca taşınabilir olmalı ve aynı zamanda mümkün olan en küçük plastik deformasyona, yani mümkün olan en düşük kesme kuvvetine sahip olmalıdır).

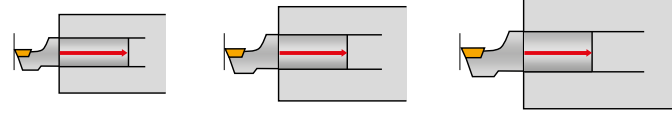

Takım gövdesi kesiti (bağlama rijitliği) – bağlamanın rijit olması önemlidir. Bu nedenle, mümkün olan en büyük gövde kesitine sahip bağlanabilen kesici takımların kullanılmasını tavsiye ederiz.. Ayrıca monoblok kullanmayı da tercih ediyoruz (PSC).

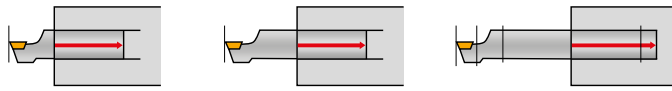

Kullanma mesafesi (bağlama rijitliği) – takım kullanma mesafesi veya bağlamanın kendisinin rijit olması da büyük önem taşır. Bu nedenle, kullanma mesafesinin en aza indirilmesini öneririz.

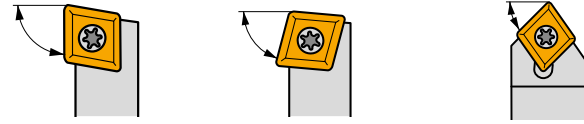

Ana kesme kenarı açısı - ideal olarak, takım ayarlama açısı 90° 'ye yakın olmalıdır, yani kuvvetler mümkün olduğunca tezgah milinin eksenine yönlendirilmelidir.

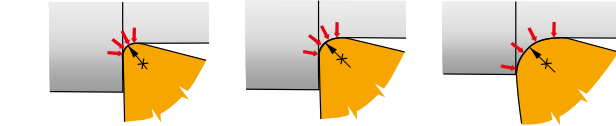

Uç yarıçapı – titreşim riski varsa mümkün olduğu kadar küçük uç yarıçapına sahip bir kesici uç seçilmelidir.

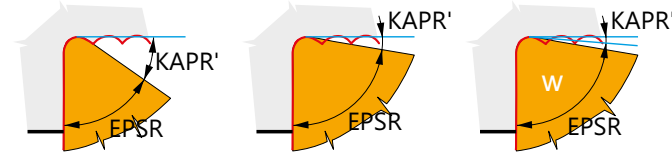

Köşe açısı ve küçük kesme kenarı açısı – bu durumda mümkün olduğu kadar küçük uç açısına sahip bir kesici uç seçilmesi önerilir, ör. V (35°), D veya K (55°) veya T (60°) gibi. C veya W şekilleri ya da SİLİCİ geometrisine sahip kesici uçlar önerilmez. Lütfen bunun her zaman geçerli olmadığını unutmayın (burulma titreşimleri de meydana gelirse, bu uçların uygulanması yararlı olabilir).

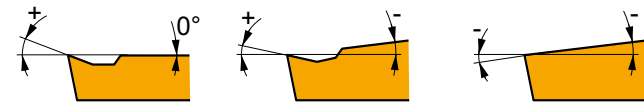

Geometri – ince duvarlı ve ince parçaları tormalarken, öncelikle pozitif geometriye sahip pozitif kesici uçların, ardından pozitif geometriye sahip negatif kesici uçların tercih edilmesi önerilir ve sadece başka seçenek yoksa nötr ile negatif geometri arası kesici uçlar seçilmelidir.

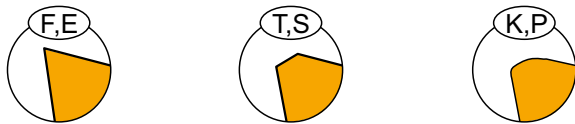

Mikro geometri (kesici kenar tasarımı) – titreşim riskini azaltmak için, mümkün olan en keskin kesme kenarı geometrisine sahip kesici uçların seçilmesi gerekir. T-bölgesi olan kesici uçlar kullanıyorsanız, bunlar olabildiğince dar ve pozitif olmalıdır. Takımın mümkün olduğunca az kesme direnci oluşturması çok önemlidir.

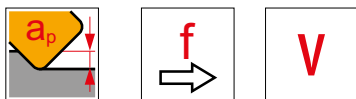

Kesme koşulları:

- 1) Kesme derinliğini seçerken, daima kesme derinliğinin kesici ucun yarıçapından daha büyük olduğundan emin olun.
 - 2) İlerlemeyi seçerken, spesifik kesme direncinin azalan talaş kalınlığıyla arttığını dikkate alın, yani çok düşük ilerlemeler kullanmayın ($0,1 \text{ mm}'$ nin altında).
 - 3) Titreşim varsa kesme hızı değişikliği (+/-) de yardımcı olabilir - bu durum tezgahın kendi frekansı ile ilgilidir.
- NOT: Genellikle kesme derinliğini azaltmak (yarıçapın altına inmeden) ve ilerlemeyi artırmak yarar sağlar.



Aşınmış kesici uçları kullanmayın - yanağın aşınması kesme kuvvetlerinde artışa ve dolayısıyla titreşim riskine neden olur. Takım bağlaması izin veriyorsa kesme kenarını eksenin üzerinde çapın yaklaşık %2'si kadar ilerletin (dış çap tormalamada).

KESME KOŞULLARININ SEÇİMİ

Talaş kırıcı seçimi

Talaşın şekli birkaç faktöre bağlıdır - işlenen bileşenin özellikleri, malzeme mukavemeti, tokluk ve mikro yapı, kesici uç kalitesinin özellikleri, özellikle sürtünme özellikleri (talaş yüzeyinde), kesme kenarının geometrisi, kesme koşulları ve talaş kırıcı tipi, ayrıca tezgahın statik ve dinamik özellikleri.

Kesme sürecindeki bu faktörlerin neredeyse tamamı, talaşın şeklini birleştirmek ve belirlemek için devreye girer (kesme işlemi, talaşın

akışı veya kıvrılması – toplandığında işleme alanında tıkanmaya neden olabilir). Her bir talaş kırıcı, tanımlanmış bir ilerleme aralığında ve kesme derinliğinde çalışır.

Talaş kırıcının çalıştığı minimum ilerleme, Üst Alan " x " genişliğine ve açısına bağlıdır. Maksimum ilerleme, kesme kenarından talaş kırıcının ucuna kadar olan y mesafesine ve talaş kırıcının z derinliğine bağlıdır.

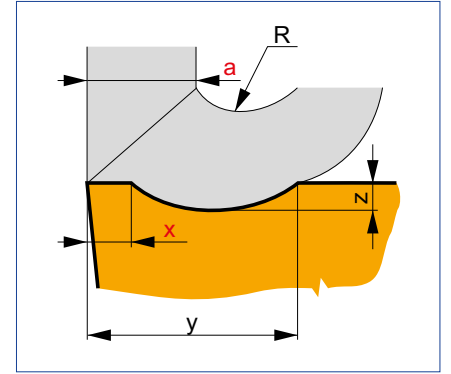
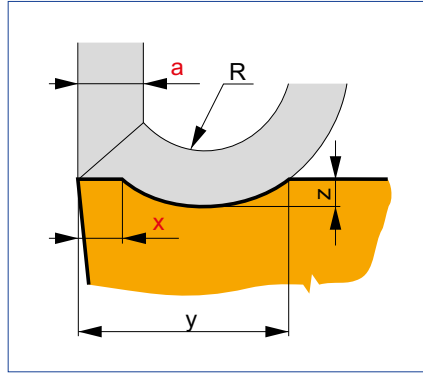
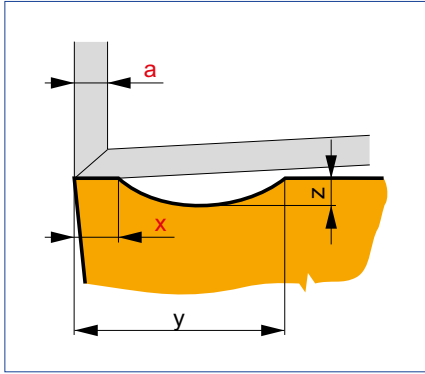

Eğer " a " tabakasının kalınlığı (ayar açısı $KAPR = 90^\circ$, ilerlemeye eşit) T-bölgesi " x " değerinden önemli ölçüde daha küçükse, talaş sadece pah ile temas halindedir. Talaş kırıcıya giremez ve bu nedenle kırılmaz (resme bakın).

Eğer " f " ilerlemesi daha büyükse (kalınlık " a " derinliğinden büyükse ve $x < a$ (f) olursa) talaş, talaş kırıcıya girer ve R yarıçapının belirli değerlerinde eğilir (resme bakın).

$x \ll a$ durumunda (resme bakın) talaş çok fazla deforme olur (talaş ezilir). Talaş, talaş kırıcıyı kaçırırsa kırılmaz.

Tüm talaş kırıcılar, belirli kesme koşullarında çalışır. Bu nedenle, en yaygın kullanılan kesme derinliği ve ilerleme kombinasyonlarını tanımlamak için talaş kırma alanı sürekli bir aralık olarak gösterilir (aşağıdaki resme bakın). Talaş kırıcı uygulama aralıkları birbirlerinin üzerine biner.

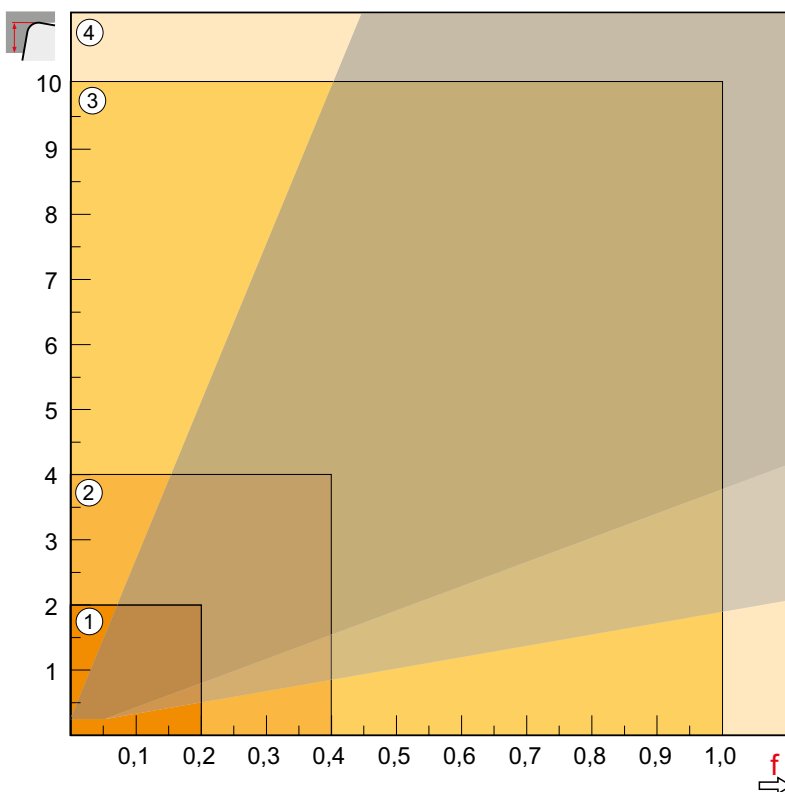

1	FF F	f → 0.05 – 0.2	a_p ↓ 0.05 – 2
2	M	f → 0.2 – 0.4	a_p ↓ 2 – 4
3	R	f → 0.4 – 1.0	a_p ↓ 4 – 10
4	HR	f → > 1.0	a_p ↓ > 10

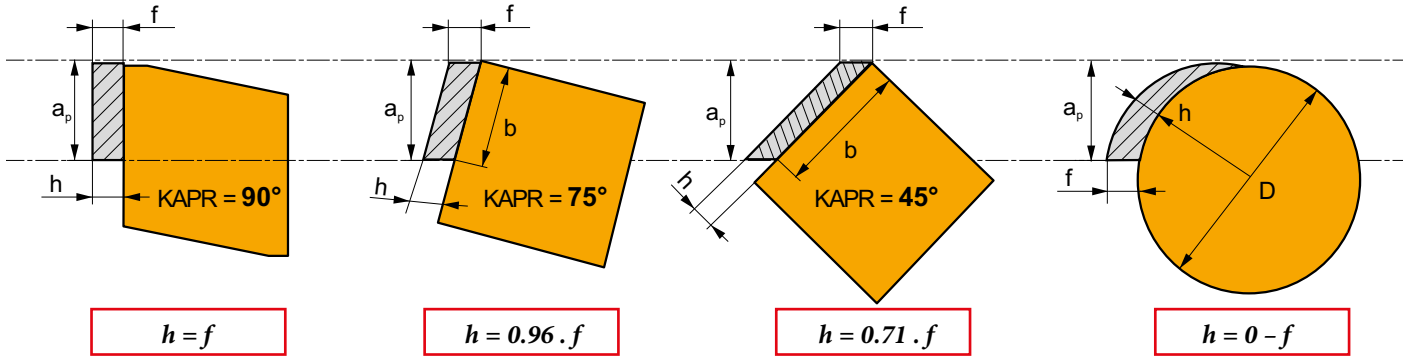

Optimum kesme derinliği ve ilerleme kombinasyonu, her malzeme için farklılık gösterir. Aşağıdaki tabloda, b (talaş genişliği) ile h (talaş kalınlığı) arasındaki optimum oran aralıkları gösterilmiştir. 90°'ye yakın ayar açıları için bu oran, esasen kesme derinliğinin ilerlemeye oranıdır. Bkz. resim.

Malzeme		min b/h	max b/h	
P		5	15	
M		8	12	
K		3	30	
N		9	11	
S		8	12	
H	Kare talaş $b=h$	5	20	Şerit talaş $b/h > 30$

Tablodan da anlaşılacağı gibi, kesme koşullarını seçerken kare talaş, yani genişliğin talaş kalınlığına yakın olduğu değerlerden kaçınmalısınız. Ayrıca diğer taraftan düşük ilerleme ve yüksek kesme derinliği sonucu ortaya çıkan şerit talaştan da kaçınılmalıdır.

Yukarıdaki tabloda, en sorunlu talaş oluşumunun demir içermeyen

metal alaşımları, özellikle düşük silikon içeriği olan veya olmayan alüminyum alaşımları ile ilgili olduğu görülmektedir. Bunu süper alaşımlar ve paslanmaz çelikler (özellikle östenitik ve dubleks çelikler) takip eder. Ardından çelikler gelir ve en iyi durum sertleştirilmiş malzemeler ve dökme demirlerle elde edilir.

KESİCİ TAKIM SEÇİMİ

Ayrıca, talaş oluşum diyagramının, artan kesme kenarı uzunluğuyla (kesici uç boyutu) daha yüksek kesme derinliklerine (yukarı) ve artan yarıçapla daha yüksek ilerlemelere (sağa) doğru hareket ettiğini unutmayın.

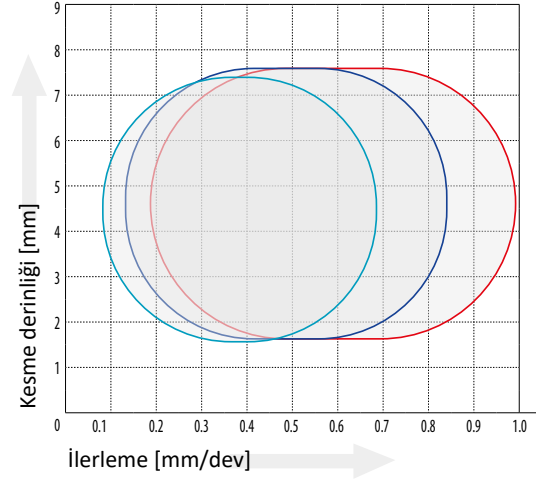
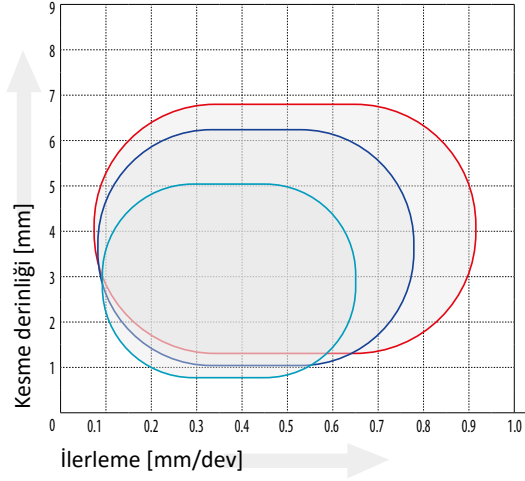

- İç çember çapı IC = 19.050 [mm] olan kesici uç
- İç çember çapı IC = 15.875 [mm] olan kesici uç
- İç çember çapı IC = 12.700 [mm] olan kesici uç

- Uç yarıçapı RE = 1.6 [mm] olan kesici uç
- Uç yarıçapı RE = 1.2 [mm] olan kesici uç
- Uç yarıçapı RE = 0.8 [mm] olan kesici uç

Talaşın şeklinin yanı sıra, tahliye yönü de çok önemlidir. Aşağıdaki şekil üzerinde talaş boşaltmanın temel yönleri gösterilmiştir:

- 1 – iş parçasından ilerleme yönünde,
- 2 – iş parçasına doğru ilerleme yönünde
- 3 – iş parçasına doğru ilerleme yönünün aksinde,
- 4 – iş parçasından ilerleme yönünün aksinde,



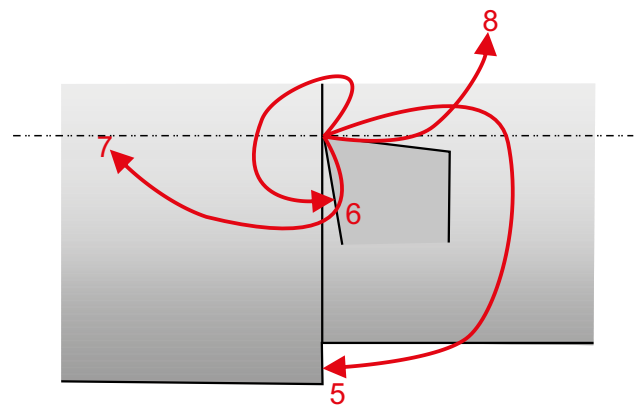
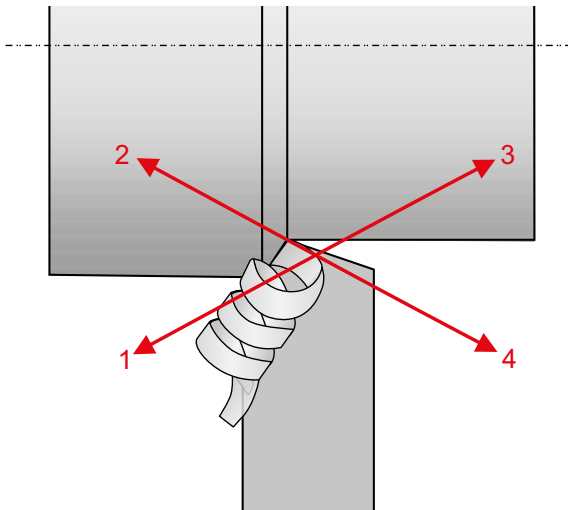

- 5 – kesme alanı yüzeyi karşısında kırılmış,
- 6 – Takım yanında kırılmış,
- 7 – işleme yapılan yüzey karşısında kırılmış,
- 8 – işlenmiş yüzey karşısında kırılmış,

Açıktır ki, işlenmiş yüzeyin hasar görmesine veya çizilmesine neden olabilecek yönler istenmez.



Aşağıdaki bölümde, yapılandırılmış gruplar halinde sunulan tüm geometriler açıkça belirtilmiştir. Bu tablolarda kendiniz için en uygun ve doğru seçimi bulabilirsiniz.

TORNALAMA UCU GEOMETRİLERİNE GENEL BAKIŞ

POZİTİF KESİCİ UÇLAR İSO S bağlama işareti		NEGATİF KESİCİ UÇLAR İSO P, M, D bağlama işareti		KESME GEOMETRİSİ KANAL AÇMA UÇLARI X ve G bağlama işareti	
					
371 (RCMT)	565	000 (LNUX)	575	GM (GL.D)	586
372 (RCMT)	565	002 (LNUX)	575	MM (GL.D)	586
...W	565	003 (LNUX)	575	PM (GL. D)	586
AL	565	08 (RNMG)	575	PR (GL. D)	586
DR4 (SCMT)	566	81 (RNMG)	576	13 CM (LCMF)	587
FF	566	432 (LNMX)	576	13 F (LCM.)	587
FF2	566	923	576	13 MP (LCM.)	587
FM	566	...A	576	16 CM (LCM.)	587
FM (RCMT)	567	DR	577	16 F (LCM.)	588
FM2	567	FF	577	16 M (LCM.)	588
NF1	567	FM	577	16 MP (LCM.)	588
NF2	567	HR	577	20 F1 (LCMF)	588
OR (SCMT)	568	HR2	578	20 M2 (LCMF)	589
RF	568	KR	578	30 F (LCM.)	589
RM	568	M	578	F1 (LFMX)	589
RM3	568	NF	578	F2 (LFMX)	589
SF2	569	NM	579	M2 (LFMX)	590
SF3	569	NMR	579	LFUX	590
SI	569	NR	579	TN. EXT	591
SR (SCMT)	569	NRM	579	TN. INT	591
UR (RCMT)	570	NR2	580	X61	591
UR	570	OR	580	X61 R	591
W-FM	570	OR1	580		
W-UR	570	R	580		
46	571	RM	581		
47	571	SF	581		
48	571	SI	581		
61	571	SM	581		
.PUN	572	SR	582		
		W-MR	582		
		W-F	582		
		W-M	582		
		W-NM	583		
POZİTİF KESİCİ UÇLAR İSO P, M, D bağlama işareti		NEGATİF KESİCİ UÇLAR İSO C bağlama işareti			
					
31 (RCMX)	573	22	584		
321 (RCMX)	573	32	584		
331 (RCMX)	573	72	584		
361 (RCMX)	573	73	584		
RF1 (RCMX)	574	74	585		
RM1 (RCMX)	574				
RM2 (RCM.)	574				
RR2 (RCM.)	574				

KESME GEOMETRİSİ POZİTİF KESİCİ UÇLAR – İSO S BAĞLAMA İŞARETİ

371 (RCMT)

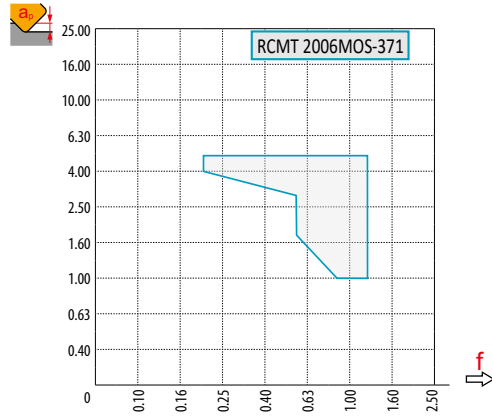
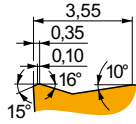

P	M	K	N	S	H
■		■			
f	0.20 – 1.20				
a_p	1.0 – 5.0				
?	RCMT				

372 (RCMT)

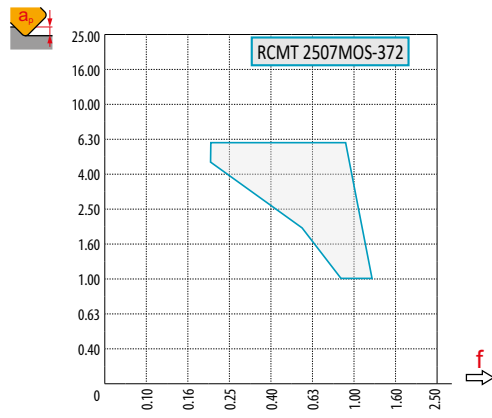
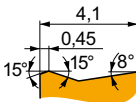

P	M	K	N	S	H
■		■			
f	0.20 – 1.20				
a_p	1.0 – 6.0				
?	RCMT				

...W

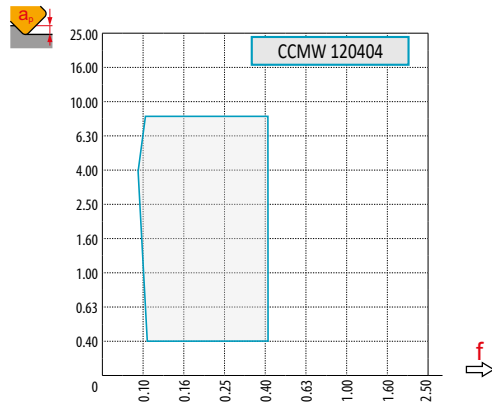
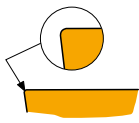

P	M	K	N	S	H
		■			■
f	0.05 – 0.60				
a_p	0.4 – 8.4				
?	CCMW, DCMW, SCMW, RCMW, TCMW, VCMW				

AL

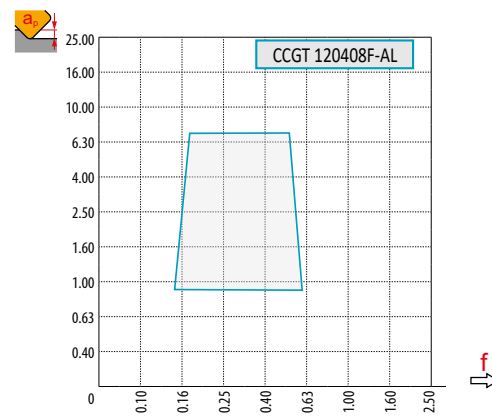



P	M	K	N	S	H
			■	■	
f	0.05 – 0.60				
a_p	0.2 – 7.0				
?	CCGT, DCGT, SCGT, RCGT, TCGT, VCGT, WCGT				

KESME GEOMETRİSİ POZİTİF KESİCİ UÇLAR – İSO S BAĞLAMA İŞARETİ

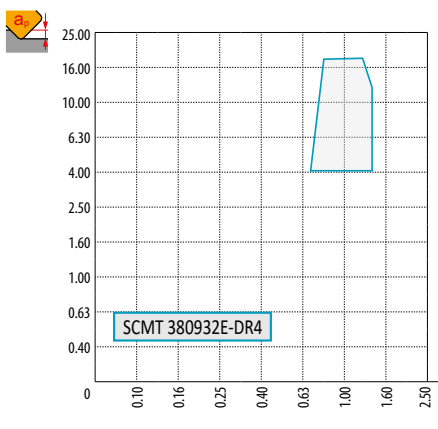
DR4 (SCMT)



SCMT 380932E-DR4

P	M	K	N	S	H
■	▣	■	■	■	■
f 0.70 – 1.40					
a _p 4.0 – 18.0					
					
					
 SCMT					

FF

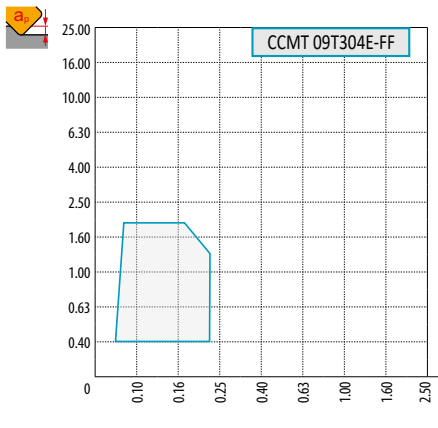

CCMT 09T304E-FF

P	M	K	N	S	H
■	▣	■	■	■	■
f 0.05 – 0.23					
a _p 0.2 – 2.0					
					
					
 CCMT, DCMT					

FF2

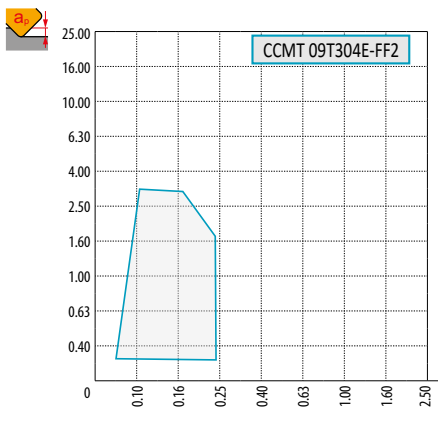

CCMT 09T304E-FF2

P	M	K	N	S	H
■	▣	■	■	■	■
f 0.02 – 0.28					
a _p 0.20 – 3.0					
					
					
 CCMT, CCGT, DCGT, DCMT, SCMT, TCMT, VBMT, VCGT, VCGX, WCGT					

FM

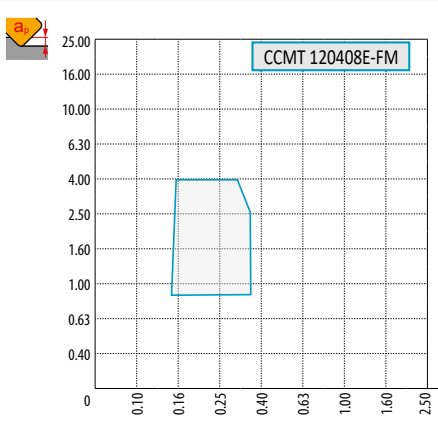



CCMT 120408E-FM

P	M	K	N	S	H
■	■	▣	▣	■	■
f 0.05 – 0.45					
a _p 0.2 – 4.0					
					
					
 CCMT, DCMT, SCMT, TCMT, VBMT, WCMT					

KESME GEOMETRİSİ POZİTİF KESİCİ UÇLAR – İSO S BAĞLAMA İŞARETİ

FM (RCMT)



RCMT 1204MOE-FM

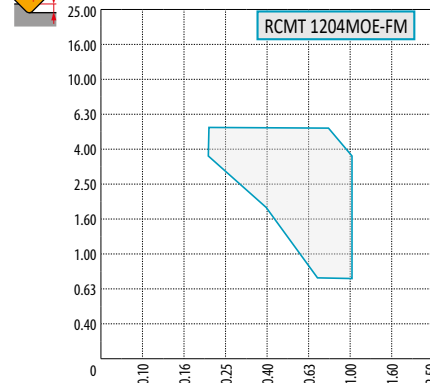

P	M	K	N	S	H
■	■	▣	▣	■	■
f	0.10 – 1.0				
a_p	0.3 – 5.0				

? RCMT

FM2



CCMT 09T304E-FM2

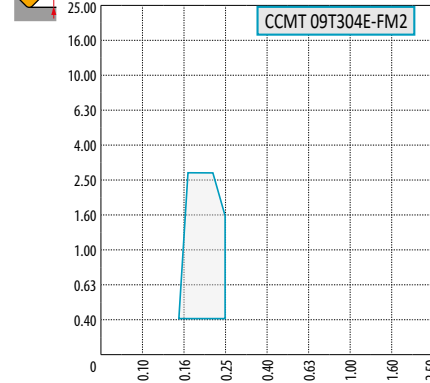

P	M	K	N	S	H
■	▣	■	■	■	■
f	0.04 – 0.4				
a_p	0.2 – 4.0				

? CCMT, DCMT, ECMT, SCMT, TCMT, VBMT, VCGT

NF1



CCGT 09T304E-NF1

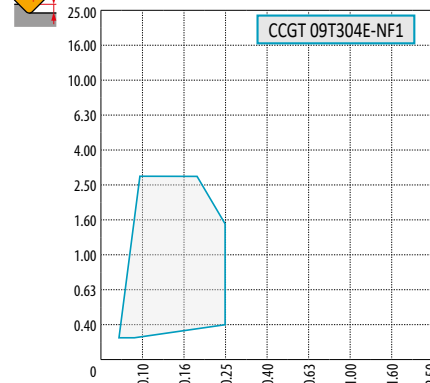

P	M	K	N	S	H
■	■	■	▣	■	▣
f	0.04 – 0.35				
a_p	0.3 – 3.5				

? CCGT, DCGT, SCGT, TCGT

NF2



CCMT 09T304E-NF2

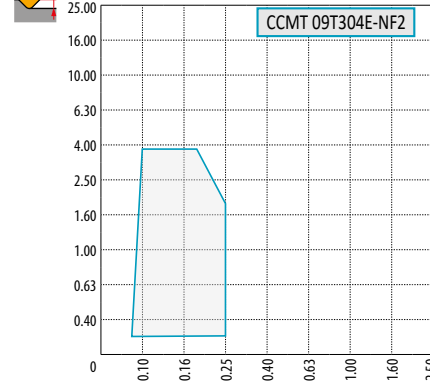





P	M	K	N	S	H
▣	■	▣	▣	■	■
f	0.05 – 0.45				
a_p	0.2 – 4.0				

? CCMT, EPMT, SCMT, TCMT, VCGT

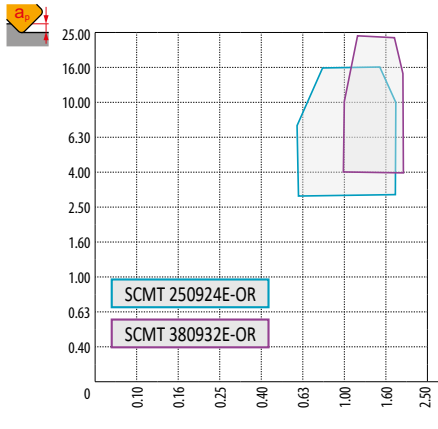
KESME GEOMETRİSİ POZİTİF KESİCİ UÇLAR – İSO S BAĞLAMA İŞARETİ

OR (SCMT)





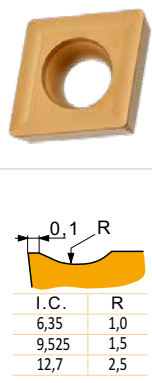

P	M	K	N	S	H
■	■	■	■	■	■
f					
0.60 – 2.00					
a_p					
3.0 – 24.0					
					
					
 SCMT					

RF

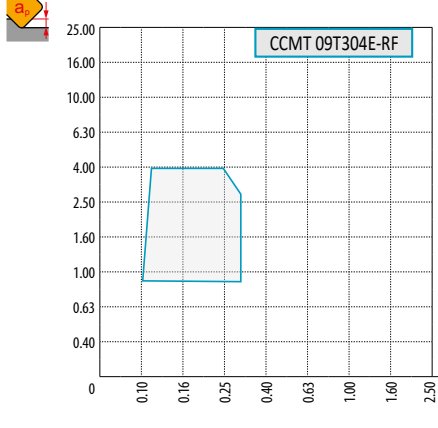





I.C.	R
6,35	1,0
9,525	1,5
12,7	2,5

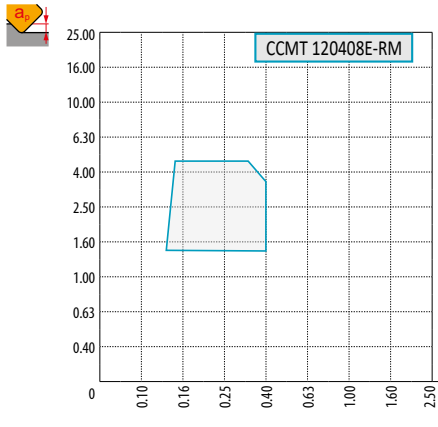

P	M	K	N	S	H
■	■	■	■	■	■
f					
0.10 – 0.60					
a_p					
0.8 – 8.0					
					
					
 CCMT, DCMT, SCMT, TCMT, WCMT					



RM

P	M	K	N	S	H
■	■	■	■	■	■
f					
0.10 – 0.50					
a_p					
0.8 – 4.5					
					
					
 CCMT, DCMT, SCMT, TCMT, VBMT					

RM3

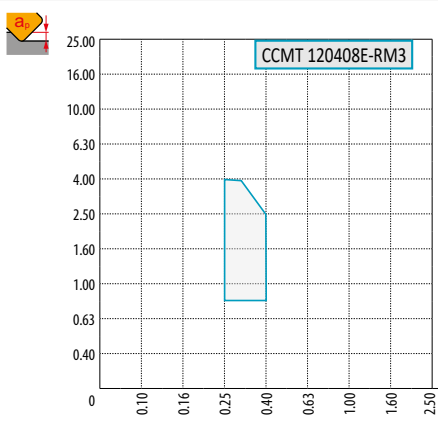
P	M	K	N	S	H
■	■	■	■	■	■
f					
0.15 – 0.90					
a_p					
0.4 – 6.00					
					
					
 CCMT, SCMT, TCMT, RCMT					

KESME GEOMETRİSİ POZİTİF KESİCİ UÇLAR – İSO S BAĞLAMA İŞARETİ

SF2

P	M	K	N	S	H
☐	■	■	☐	■	
f	0.02 – 0.28				
a_p	0.1 – 2.5				

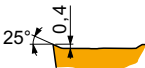
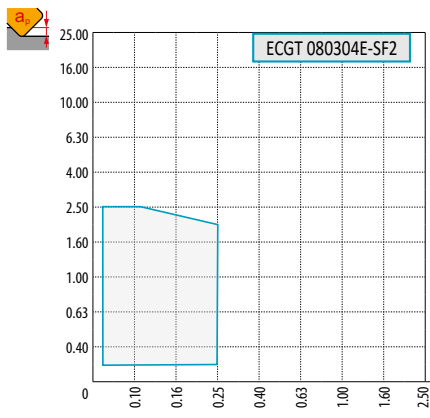
? ECGT, VCGT

SF3

P	M	K	N	S	H
☐	■	☐	■	■	☐
f	0.02 – 0.35				
a_p	0.2 – 4.00				

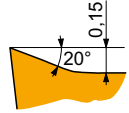
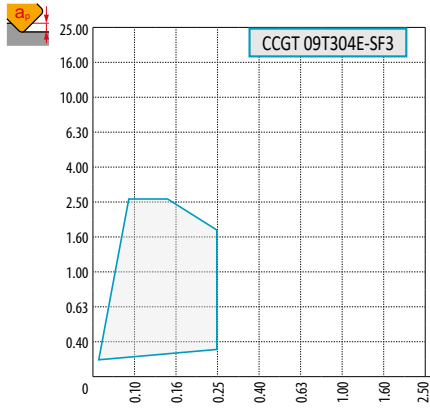
? CCGT, DCGT, ECGT, SCGT, TCGT, VCGT

SI

P	M	K	N	S	H
■	■	☐		■	
f	0.08 – 0.45				
a_p	0.4 – 4.0				

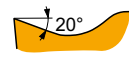
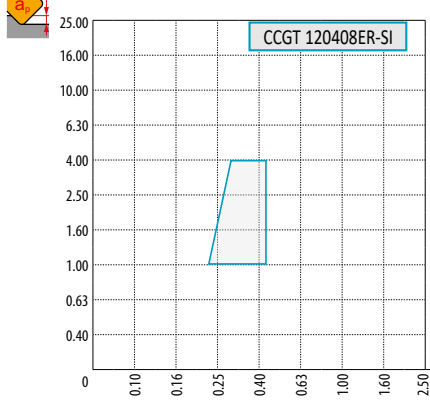
? CCGT, TCGT



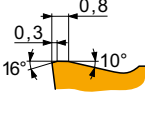
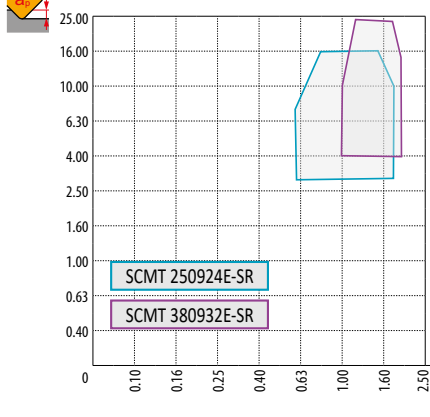

SR (SCMT)





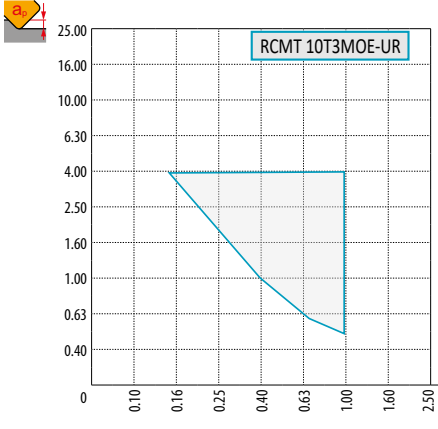
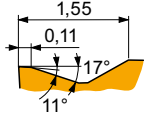





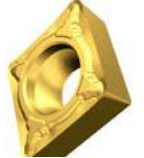
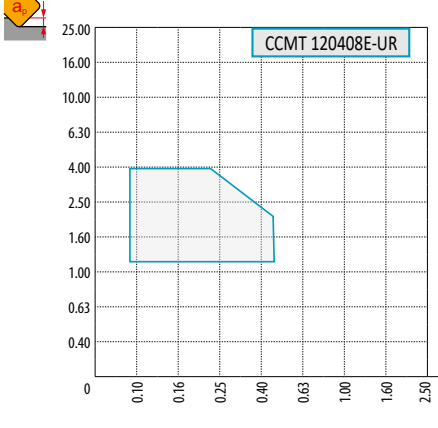
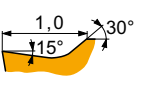

P	M	K	N	S	H
■	■	■			
f	0.60 – 2.0				
a_p	3.0 – 24.0				



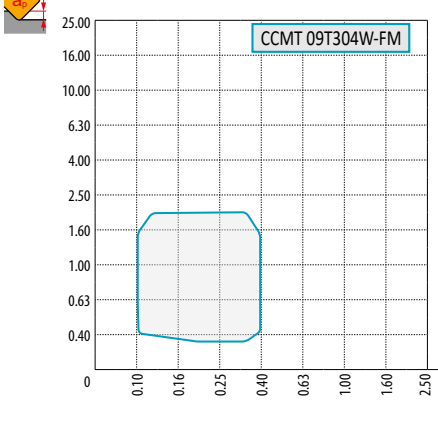
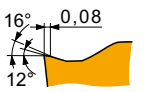

? SCMT

KESME GEOMETRİSİ POZİTİF KESİCİ UÇLAR – İSO S BAĞLAMA İŞARETİ

UR (RCMT)		 <p style="text-align: center;">RCMT 10T3M0E-UR</p>	<table border="1" style="width: 100%; border-collapse: collapse;"> <tr> <td style="background-color: #0070C0; color: white; text-align: center;">P</td> <td style="background-color: #FFD700; text-align: center;">M</td> <td style="background-color: #DC143C; text-align: center;">K</td> <td style="background-color: #90EE90; text-align: center;">N</td> <td style="background-color: #FFDAB9; text-align: center;">S</td> <td style="background-color: #B0C4DE; text-align: center;">H</td> </tr> <tr> <td style="text-align: center;">■</td> <td style="text-align: center;">▣</td> <td style="text-align: center;">■</td> <td style="text-align: center;">■</td> <td style="text-align: center;">■</td> <td style="text-align: center;">■</td> </tr> </table>	P	M	K	N	S	H	■	▣	■	■	■	■						
	P		M	K	N	S	H														
■	▣	■	■	■	■																
		<table border="1" style="width: 100%; border-collapse: collapse;"> <tr> <td style="text-align: center;">f</td> <td style="text-align: center;">0.15 – 1.00</td> </tr> <tr> <td style="text-align: center;">a_p</td> <td style="text-align: center;">0.5 – 5.0</td> </tr> </table>	f	0.15 – 1.00	a_p	0.5 – 5.0										<table border="1" style="width: 100%; border-collapse: collapse;"> <tr> <td style="background-color: #FFD700; text-align: center;">?</td> <td style="text-align: center;">RCMT</td> </tr> </table>	?	RCMT			
f	0.15 – 1.00																				
a_p	0.5 – 5.0																				
?	RCMT																				

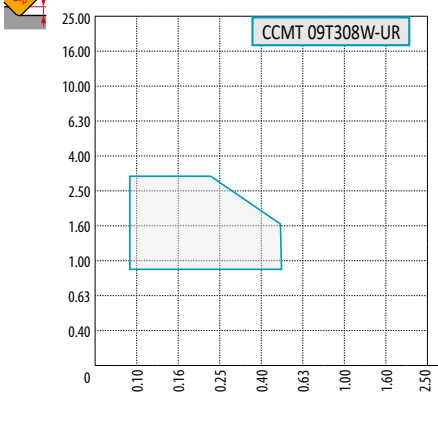
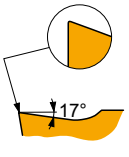
UR		 <p style="text-align: center;">CCMT 120408E-UR</p>	<table border="1" style="width: 100%; border-collapse: collapse;"> <tr> <td style="background-color: #0070C0; color: white; text-align: center;">P</td> <td style="background-color: #FFD700; text-align: center;">M</td> <td style="background-color: #DC143C; text-align: center;">K</td> <td style="background-color: #90EE90; text-align: center;">N</td> <td style="background-color: #FFDAB9; text-align: center;">S</td> <td style="background-color: #B0C4DE; text-align: center;">H</td> </tr> <tr> <td style="text-align: center;">■</td> <td style="text-align: center;">▣</td> <td style="text-align: center;">■</td> <td style="text-align: center;">■</td> <td style="text-align: center;">■</td> <td style="text-align: center;">■</td> </tr> </table>	P	M	K	N	S	H	■	▣	■	■	■	■						
	P		M	K	N	S	H														
■	▣	■	■	■	■																
		<table border="1" style="width: 100%; border-collapse: collapse;"> <tr> <td style="text-align: center;">f</td> <td style="text-align: center;">0.10 – 0.40</td> </tr> <tr> <td style="text-align: center;">a_p</td> <td style="text-align: center;">1.0 – 4.0</td> </tr> </table>	f	0.10 – 0.40	a_p	1.0 – 4.0										<table border="1" style="width: 100%; border-collapse: collapse;"> <tr> <td style="background-color: #FFD700; text-align: center;">?</td> <td style="text-align: center;">CCMT, DCMT, RCMT, SCMT, TCMT, VCMT, VBMT, WCMT</td> </tr> </table>	?	CCMT, DCMT, RCMT, SCMT, TCMT, VCMT, VBMT, WCMT			
f	0.10 – 0.40																				
a_p	1.0 – 4.0																				
?	CCMT, DCMT, RCMT, SCMT, TCMT, VCMT, VBMT, WCMT																				

W-FM		 <p style="text-align: center;">CCMT 09T304W-FM</p>	<table border="1" style="width: 100%; border-collapse: collapse;"> <tr> <td style="background-color: #0070C0; color: white; text-align: center;">P</td> <td style="background-color: #FFD700; text-align: center;">M</td> <td style="background-color: #DC143C; text-align: center;">K</td> <td style="background-color: #90EE90; text-align: center;">N</td> <td style="background-color: #FFDAB9; text-align: center;">S</td> <td style="background-color: #B0C4DE; text-align: center;">H</td> </tr> <tr> <td style="text-align: center;">■</td> <td style="text-align: center;">■</td> <td style="text-align: center;">■</td> <td style="text-align: center;">■</td> <td style="text-align: center;">■</td> <td style="text-align: center;">■</td> </tr> </table>	P	M	K	N	S	H	■	■	■	■	■	■						
	P		M	K	N	S	H														
■	■	■	■	■	■																
		<table border="1" style="width: 100%; border-collapse: collapse;"> <tr> <td style="text-align: center;">f</td> <td style="text-align: center;">0.1 – 0.4</td> </tr> <tr> <td style="text-align: center;">a_p</td> <td style="text-align: center;">0.3 – 3.0</td> </tr> </table>	f	0.1 – 0.4	a_p	0.3 – 3.0										<table border="1" style="width: 100%; border-collapse: collapse;"> <tr> <td style="background-color: #FFD700; text-align: center;">?</td> <td style="text-align: center;">CCMT, DCMX</td> </tr> </table>	?	CCMT, DCMX			
f	0.1 – 0.4																				
a_p	0.3 – 3.0																				
?	CCMT, DCMX																				

W-UR		 <p style="text-align: center;">CCMT 09T308W-UR</p>	<table border="1" style="width: 100%; border-collapse: collapse;"> <tr> <td style="background-color: #0070C0; color: white; text-align: center;">P</td> <td style="background-color: #FFD700; text-align: center;">M</td> <td style="background-color: #DC143C; text-align: center;">K</td> <td style="background-color: #90EE90; text-align: center;">N</td> <td style="background-color: #FFDAB9; text-align: center;">S</td> <td style="background-color: #B0C4DE; text-align: center;">H</td> </tr> <tr> <td style="text-align: center;">■</td> <td style="text-align: center;">▣</td> <td style="text-align: center;">■</td> <td style="text-align: center;">■</td> <td style="text-align: center;">■</td> <td style="text-align: center;">■</td> </tr> </table>	P	M	K	N	S	H	■	▣	■	■	■	■						
	P		M	K	N	S	H														
■	▣	■	■	■	■																
		<table border="1" style="width: 100%; border-collapse: collapse;"> <tr> <td style="text-align: center;">f</td> <td style="text-align: center;">0.08 – 0.5</td> </tr> <tr> <td style="text-align: center;">a_p</td> <td style="text-align: center;">0.4 – 3.0</td> </tr> </table>	f	0.08 – 0.5	a_p	0.4 – 3.0										<table border="1" style="width: 100%; border-collapse: collapse;"> <tr> <td style="background-color: #FFD700; text-align: center;">?</td> <td style="text-align: center;">CCMT</td> </tr> </table>	?	CCMT			
f	0.08 – 0.5																				
a_p	0.4 – 3.0																				
?	CCMT																				

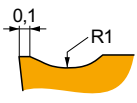

KESME GEOMETRİSİ POZİTİF KESİCİ UÇLAR – İSO C BAĞLAMA İŞARETİ

46

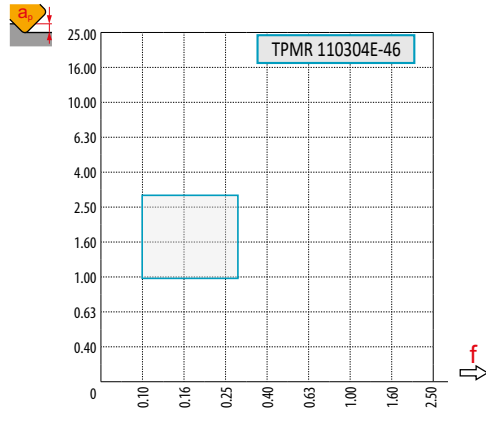





TPMPR 110304E-46

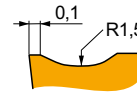

P	M	K	N	S	H
■	▣	■	■	■	■
f → 0.10 – 0.30					
a _p → 1.0 – 3.0					
					
					
? SPMR, TPMPR					

47

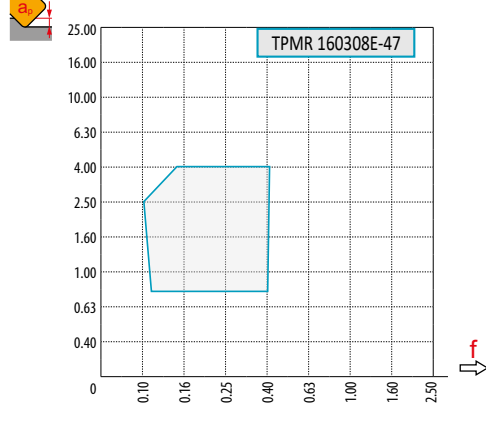





TPMPR 160308E-47

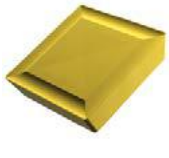
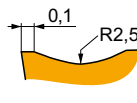

P	M	K	N	S	H
■	▣	■	■	■	■
f → 0.10 – 0.40					
a _p → 0.8 – 4.0					
					
					
? TPMPR					

48

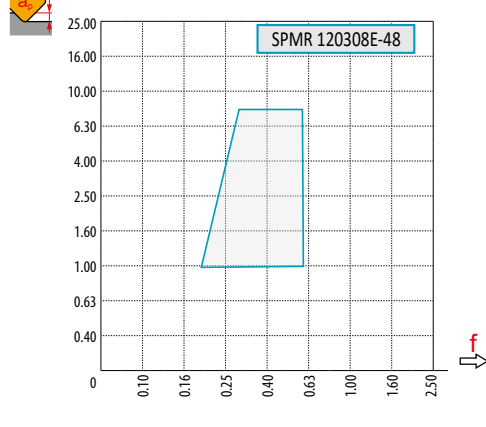





SPMR 120308E-48

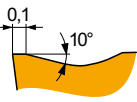

P	M	K	N	S	H
■	▣	■	■	■	■
f → 0.20 – 0.60					
a _p → 1.0 – 8.0					
					
					
? SPMR					

61

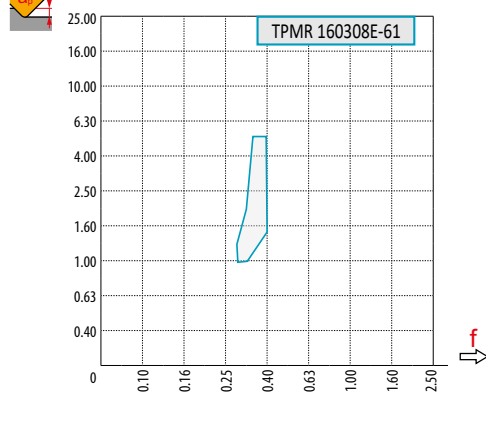

TPMPR 160308E-61

P	M	K	N	S	H
■	▣	■	■	■	■
f → 0.30 – 0.40					
a _p → 1.0 – 5.3					
					
					
? TPMPR					

KESME GEOMETRİSİ POZİTİF KESİCİ UÇLAR – İSO C BAĞLAMA İŞARETİ

.PUN

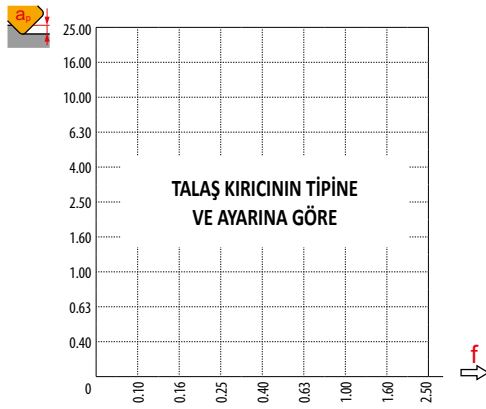
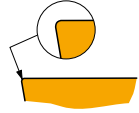

P	M	K	N	S	H
<input checked="" type="checkbox"/>		<input checked="" type="checkbox"/>			<input checked="" type="checkbox"/>
f	0.10 – 0.60				
a_p	0.4 – 17.5				
TPUN, SPUN					

KESME GEOMETRİSİ POZİTİF KESİCİ UÇLAR – İSO P, M, D BAĞLAMA İŞARETİ

31 (RCMX)

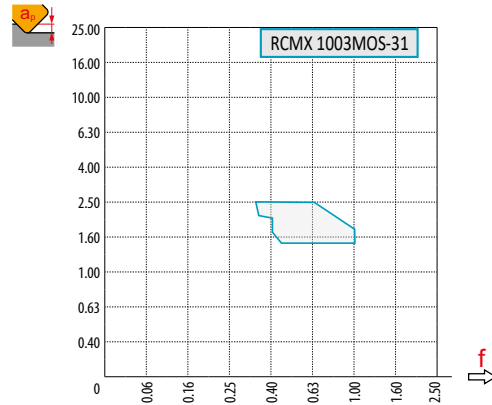
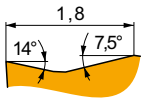

P	M	K	N	S	H
■	■	■	■	■	■
f	0.40 – 1.00				
a_p	1.5 – 2.5				
?	RCMX				

321 (RCMX)

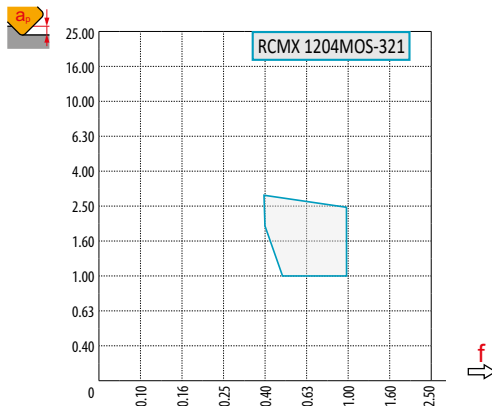
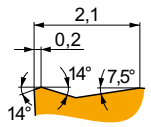

P	M	K	N	S	H
■	■	■	■	■	■
f	0.40 – 1.00				
a_p	1.0 – 3.0				
?	RCMX				

331 (RCMX)

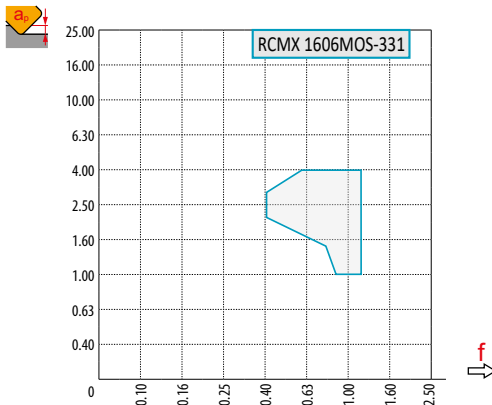
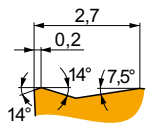





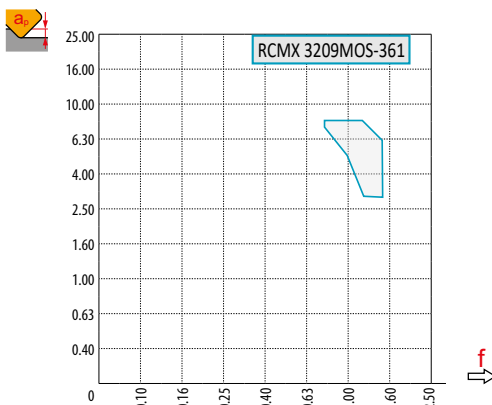
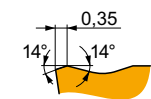





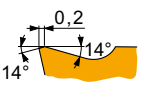
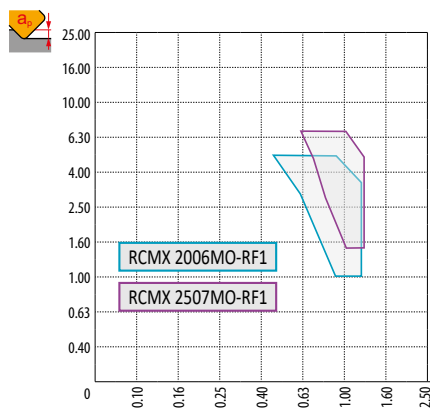







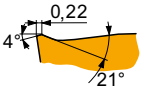
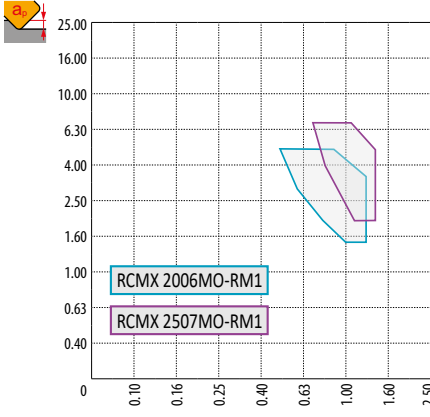







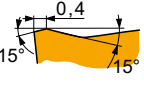
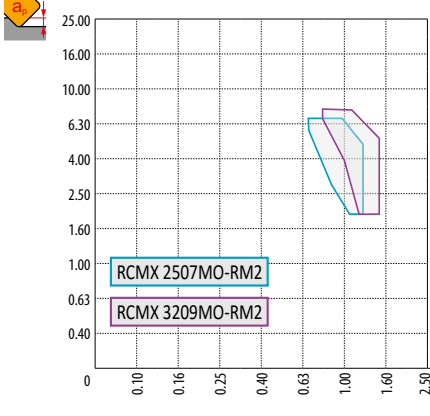



P	M	K	N	S	H
■	■	■	■	■	■
f	0.40 – 1.20				
a_p	1.0 – 4.0				
?	RCMX				

361 (RCMX)

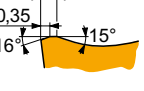
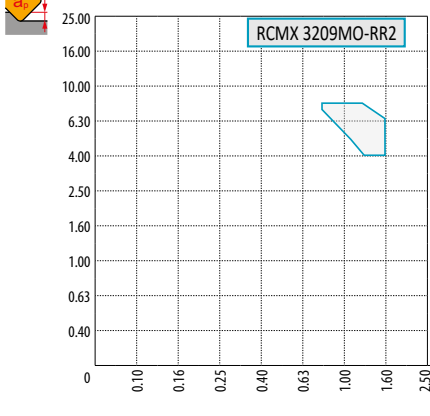

P	M	K	N	S	H
■	■	■	■	■	■
f	0.80 – 1.50				
a_p	3.0 – 8.0				
?	RCMX				



KESME GEOMETRİSİ POZİTİF KESİCİ UÇLAR – İSO P, M, D BAĞLAMA İŞARETİ

RF1 (RCMX)	 		<table border="1" style="width: 100%; border-collapse: collapse;"> <thead> <tr> <th style="background-color: #0070C0; color: white;">P</th> <th style="background-color: #FFD700;">M</th> <th style="background-color: #DC143C; color: white;">K</th> <th style="background-color: #90EE90;">N</th> <th style="background-color: #FFDAB9;">S</th> <th style="background-color: #A9A9A9;">H</th> </tr> </thead> <tbody> <tr> <td style="text-align: center;">■</td> <td></td> <td style="text-align: center;">▣</td> <td></td> <td></td> <td></td> </tr> <tr> <td style="text-align: center;">f</td> <td colspan="5">0.45 (0.60) – 1.20 (1.25)</td> </tr> <tr> <td style="text-align: center;">a_p</td> <td colspan="5">1.0 (1.5) – 5.0 (7.0)</td> </tr> <tr> <td colspan="6" style="text-align: center;">  </td> </tr> <tr> <td colspan="6" style="text-align: center;">  </td> </tr> <tr> <td colspan="6" style="text-align: center;"> ? RCMX 20, RCMX 25 </td> </tr> </tbody> </table>	P	M	K	N	S	H	■		▣				f	0.45 (0.60) – 1.20 (1.25)					a _p	1.0 (1.5) – 5.0 (7.0)																	? RCMX 20, RCMX 25					
P	M	K	N	S	H																																								
■		▣																																											
f	0.45 (0.60) – 1.20 (1.25)																																												
a _p	1.0 (1.5) – 5.0 (7.0)																																												
																																													
																																													
? RCMX 20, RCMX 25																																													
RM1 (RCMX)	 		<table border="1" style="width: 100%; border-collapse: collapse;"> <thead> <tr> <th style="background-color: #0070C0; color: white;">P</th> <th style="background-color: #FFD700;">M</th> <th style="background-color: #DC143C; color: white;">K</th> <th style="background-color: #90EE90;">N</th> <th style="background-color: #FFDAB9;">S</th> <th style="background-color: #A9A9A9;">H</th> </tr> </thead> <tbody> <tr> <td style="text-align: center;">■</td> <td></td> <td style="text-align: center;">▣</td> <td></td> <td></td> <td></td> </tr> <tr> <td style="text-align: center;">f</td> <td colspan="5">0.50 (0.70) – 1.30 (1.40)</td> </tr> <tr> <td style="text-align: center;">a_p</td> <td colspan="5">1.5 (2.0) – 5.0 (8.0)</td> </tr> <tr> <td colspan="6" style="text-align: center;">  </td> </tr> <tr> <td colspan="6" style="text-align: center;">  </td> </tr> <tr> <td colspan="6" style="text-align: center;"> ? RCMX 20, RCMX 25 </td> </tr> </tbody> </table>	P	M	K	N	S	H	■		▣				f	0.50 (0.70) – 1.30 (1.40)					a _p	1.5 (2.0) – 5.0 (8.0)																	? RCMX 20, RCMX 25					
P	M	K	N	S	H																																								
■		▣																																											
f	0.50 (0.70) – 1.30 (1.40)																																												
a _p	1.5 (2.0) – 5.0 (8.0)																																												
																																													
																																													
? RCMX 20, RCMX 25																																													
RM2 (RCM.)	 		<table border="1" style="width: 100%; border-collapse: collapse;"> <thead> <tr> <th style="background-color: #0070C0; color: white;">P</th> <th style="background-color: #FFD700;">M</th> <th style="background-color: #DC143C; color: white;">K</th> <th style="background-color: #90EE90;">N</th> <th style="background-color: #FFDAB9;">S</th> <th style="background-color: #A9A9A9;">H</th> </tr> </thead> <tbody> <tr> <td style="text-align: center;">■</td> <td></td> <td style="text-align: center;">▣</td> <td></td> <td></td> <td></td> </tr> <tr> <td style="text-align: center;">f</td> <td colspan="5">0.70 (0.80) – 1.30 (1.50)</td> </tr> <tr> <td style="text-align: center;">a_p</td> <td colspan="5">2.0 – 7.0 (8.0)</td> </tr> <tr> <td colspan="6" style="text-align: center;">  </td> </tr> <tr> <td colspan="6" style="text-align: center;">  </td> </tr> <tr> <td colspan="6" style="text-align: center;"> ? RCMX 25, RCMX 32 </td> </tr> </tbody> </table>	P	M	K	N	S	H	■		▣				f	0.70 (0.80) – 1.30 (1.50)					a _p	2.0 – 7.0 (8.0)																	? RCMX 25, RCMX 32					
P	M	K	N	S	H																																								
■		▣																																											
f	0.70 (0.80) – 1.30 (1.50)																																												
a _p	2.0 – 7.0 (8.0)																																												
																																													
																																													
? RCMX 25, RCMX 32																																													
RR2 (RCM.)	 		<table border="1" style="width: 100%; border-collapse: collapse;"> <thead> <tr> <th style="background-color: #0070C0; color: white;">P</th> <th style="background-color: #FFD700;">M</th> <th style="background-color: #DC143C; color: white;">K</th> <th style="background-color: #90EE90;">N</th> <th style="background-color: #FFDAB9;">S</th> <th style="background-color: #A9A9A9;">H</th> </tr> </thead> <tbody> <tr> <td style="text-align: center;">■</td> <td></td> <td style="text-align: center;">■</td> <td></td> <td></td> <td style="text-align: center;">▣</td> </tr> <tr> <td style="text-align: center;">f</td> <td colspan="5">0.80 – 1.60</td> </tr> <tr> <td style="text-align: center;">a_p</td> <td colspan="5">4.0 – 8.0</td> </tr> <tr> <td colspan="6" style="text-align: center;">  </td> </tr> <tr> <td colspan="6" style="text-align: center;">  </td> </tr> <tr> <td colspan="6" style="text-align: center;"> ? RCMX 32 </td> </tr> </tbody> </table>	P	M	K	N	S	H	■		■			▣	f	0.80 – 1.60					a _p	4.0 – 8.0																	? RCMX 32					
P	M	K	N	S	H																																								
■		■			▣																																								
f	0.80 – 1.60																																												
a _p	4.0 – 8.0																																												
																																													
																																													
? RCMX 32																																													

KESME GEOMETRİSİ NEGATİF KESİCİ UÇLAR – İSO P, M, D BAĞLAMA İŞARETİ

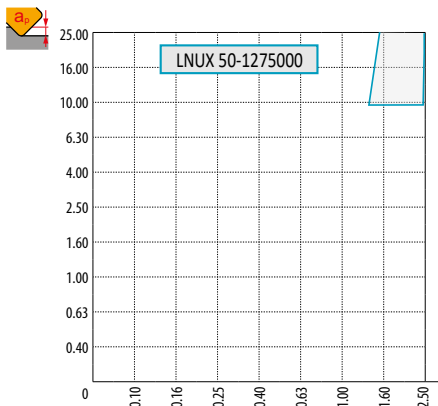

000 (LNUX)

P	M	K	N	S	H
■		■			
f	1.20 – 2.50				
a_p	10.0 – 36.0				
					
					
?	LNUX 50				

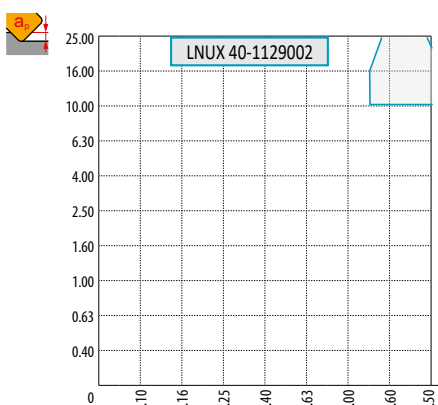

002 (LNUX)

P	M	K	N	S	H
■		■			
f	1.30 – 2.60				
a_p	10.0 – 27.0				
					
					
?	LNUX 40				

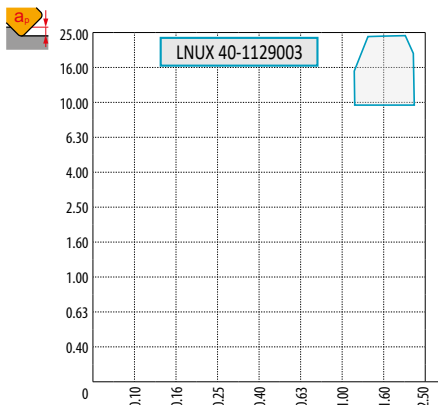

003 (LNUX)

P	M	K	N	S	H
■		■			
f	1.20 – 2.50				
a_p	10.0 – 27.0				
					
					
?	LNUX 40				

08 (RNMG)

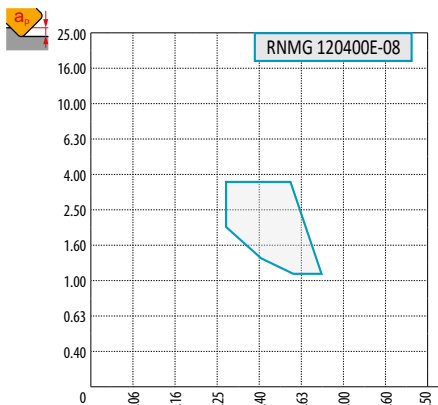
P	M	K	N	S	H
▣		▣			▣
f	0.30 – 0.80				
a_p	1.0 – 4.0				
					
					
?	RNMG				

KESME GEOMETRİSİ NEGATİF KESİCİ UÇLAR – İSO P, M, D BAĞLAMA İŞARETİ

81 (RNMG)

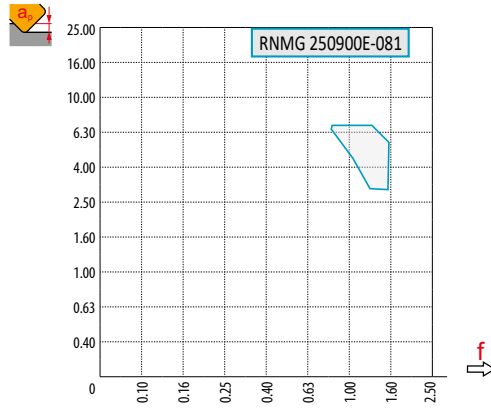
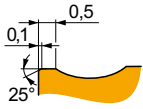

P	M	K	N	S	H
☑		☑			☑
f	0.80 – 1.20				
a_p	3.0 – 7.0				
?	RNMG				

432 (LNMX)

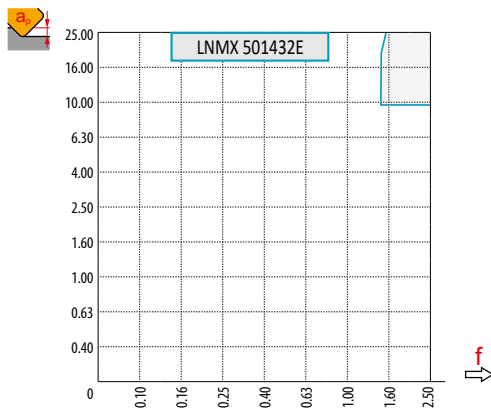
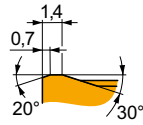

P	M	K	N	S	H
☑		☑			
f	1.50 – 2.60				
a_p	10.0 – 35.0				
?	LNMX 50				

923

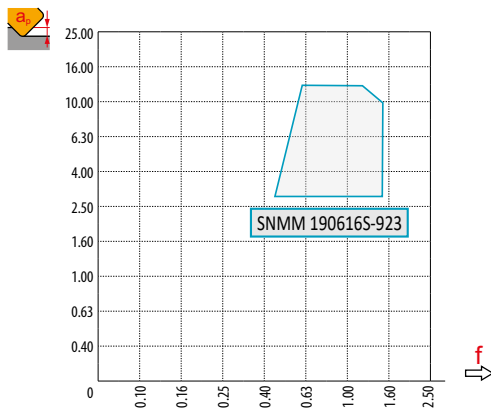
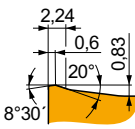

P	M	K	N	S	H
☑	☑	☑		☑	
f	0.45 – 1.50				
a_p	3.0 – 16.0				
?	CNMM, SNMM				

...A

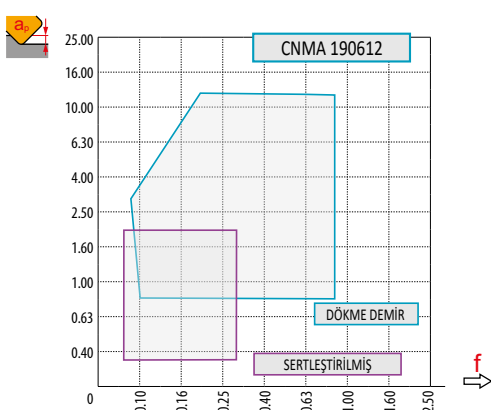
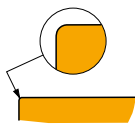

P	M	K	N	S	H
		☑			☑
f	0.10 – 1.10				
a_p	0.8 – 12.7				
?	CNMA, DNMA, SNMA, TNMA, WNMA				



KESME GEOMETRİSİ NEGATİF KESİCİ UÇLAR – İSO P, M, D BAĞLAMA İŞARETİ

DR

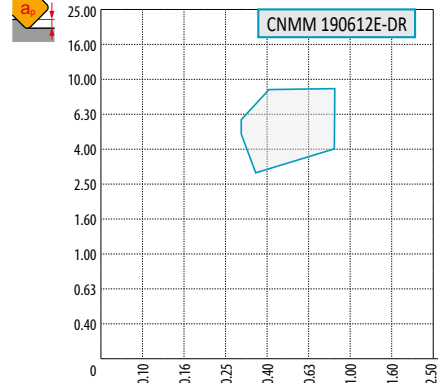

CNMM 190612E-DR





P	M	K	N	S	H
■	■	■			
f	0.30 – 0.85				
a_p	2.5 – 9.0				
					
					
?	CNMM, DNMM, SNMM, TNMM, WNMM				

FF

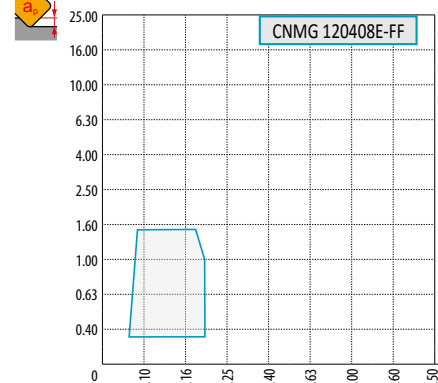

CNMG 120408E-FF





P	M	K	N	S	H
■	■	■			
f	0.06 – 0.25				
a_p	0.2 – 1.6				
					
					
?	CNMG, DNMG, TNMG, VNMG, WNMG				

FM

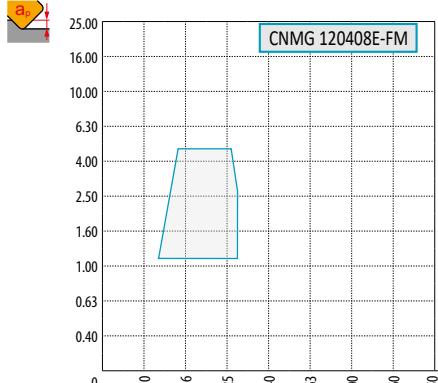

CNMG 120408E-FM





P	M	K	N	S	H
■	■	■		■	
f	0.1 – 0.5				
a_p	0.4 – 5.0				
					
					
?	CNMG, DNMG, SNMG, TNMG, VNMG, WNMG				

HR



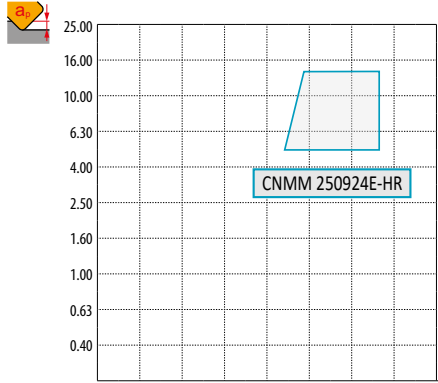







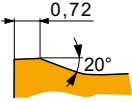
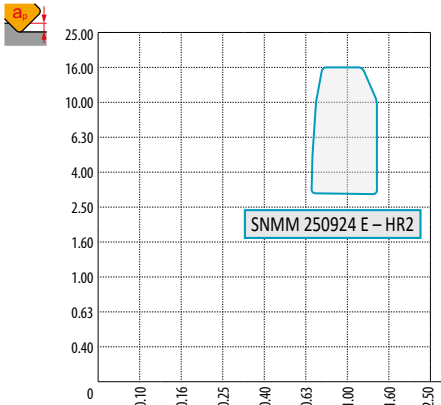

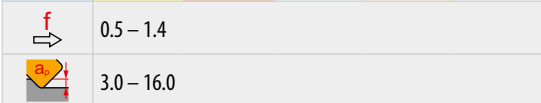

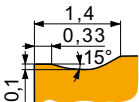
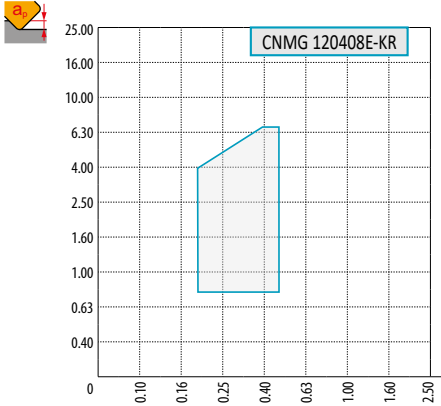
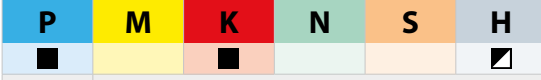

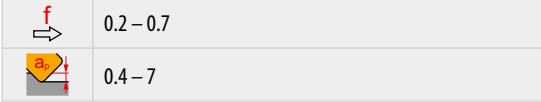
CNMM 250924E-HR

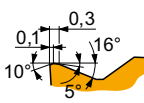
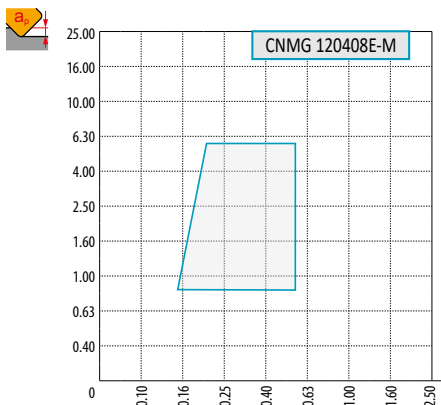

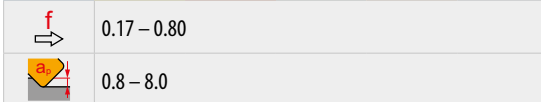
P	M	K	N	S	H
■	■	■			
f	0.50 – 1.40				
a_p	5.0 – 14.0				
					
					
?	CNMM, SNMM, TNMM				

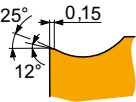
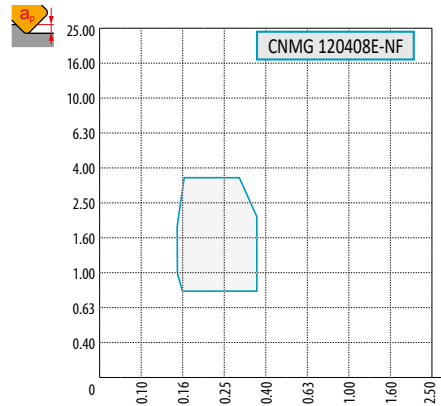
KESME GEOMETRİSİ NEGATİF KESİCİ UÇLAR – İSO P, M, D BAĞLAMA İŞARETİ

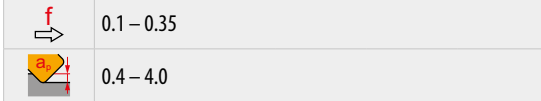
HR2			 SNMM 250924 E – HR2	
				
KR			 CNMG 120408E-KR	
				
M			 CNMG 120408E-M	
				
NF			 CNMG 120408E-NF	
				

KESME GEOMETRİSİ NEGATİF KESİCİ UÇLAR – İSO P, M, D BAĞLAMA İŞARETİ

NM



30° 0.25
10°

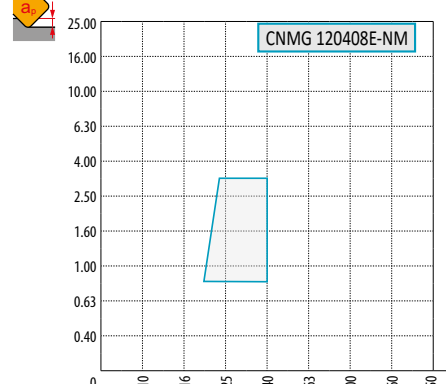

CNMG 120408E-NM

P	M	K	N	S	H
■	■	■	■	■	■
f	0.15 – 0.55				
a _p	0.5 – 8.0				



? CNMG, DNMG, TNMG, VNMG, WNMG

NMR



22° 0.31
10°

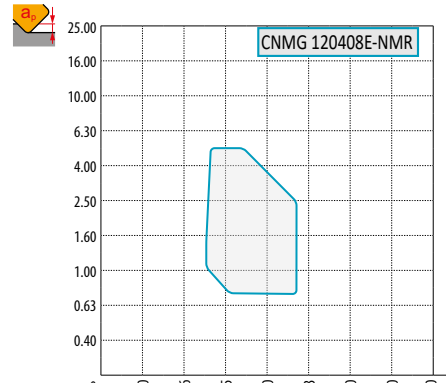

CNMG 120408E-NMR

P	M	K	N	S	H
■	■	■	■	■	■
f	0.18 – 0.70				
a _p	0.4 – 8.0				



? CNMG, DNMG, SNMG, TNMG, VNMG, WNMG

NR



0.25
23°

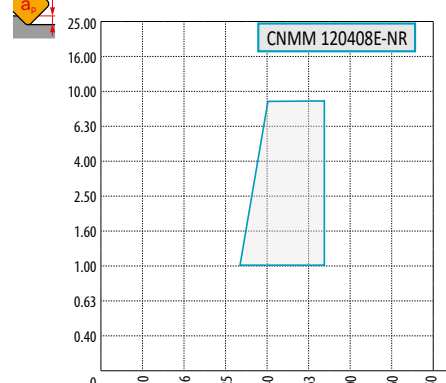

CNMM 120408E-NR

P	M	K	N	S	H
■	■	■	■	■	■
f	0.25 – 0.80				
a _p	1.0 – 9.0				



? CNMM, DNMM, SNMM, TNMM, WNMM

NRM



0.32
6° 24°

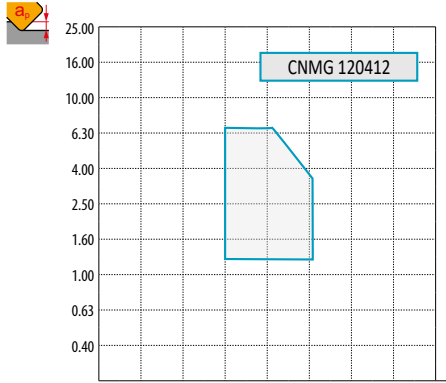

CNMG 120412

P	M	K	N	S	H
■	■	■	■	■	■
f	0.23 – 1.0				
a _p	0.8 – 16.0				







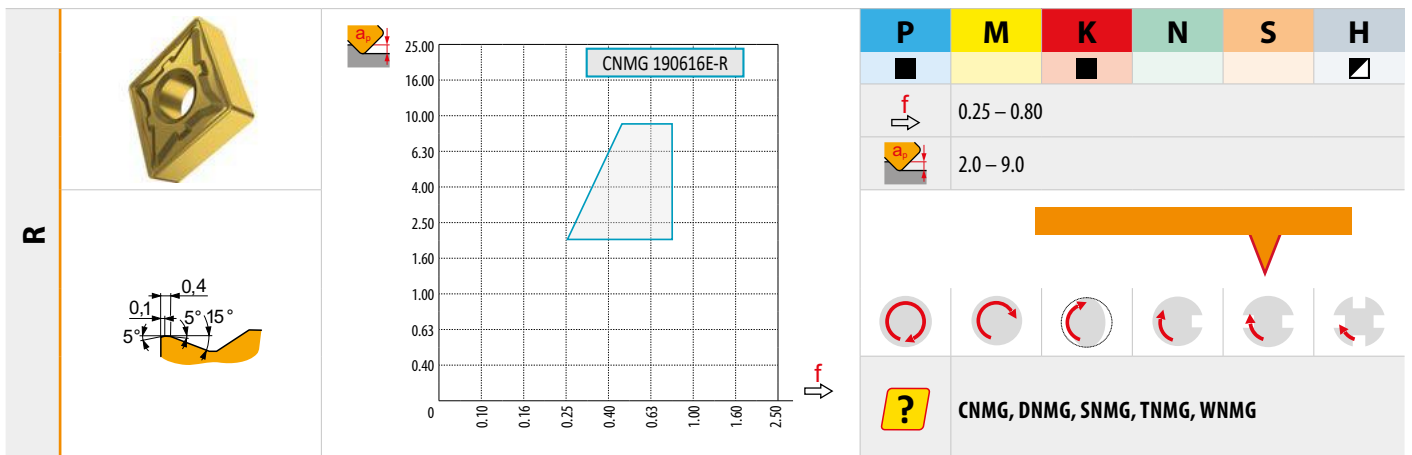
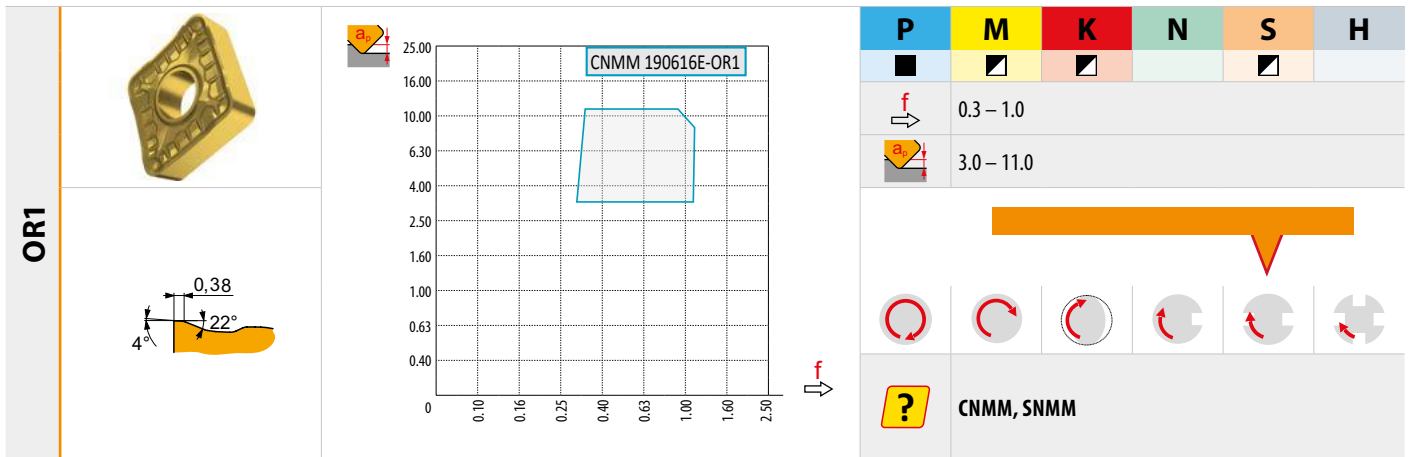
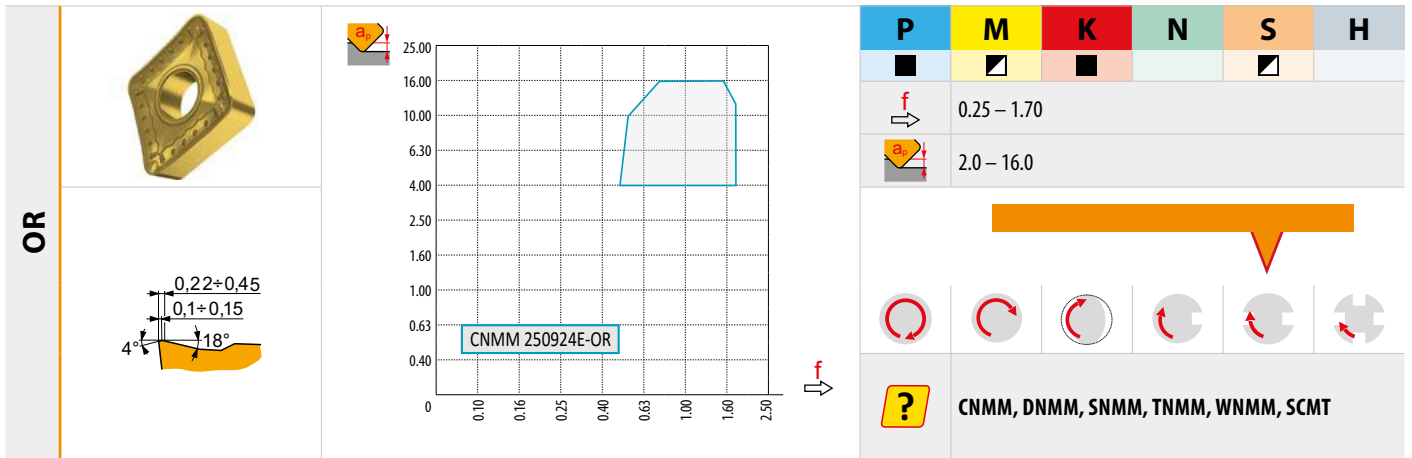
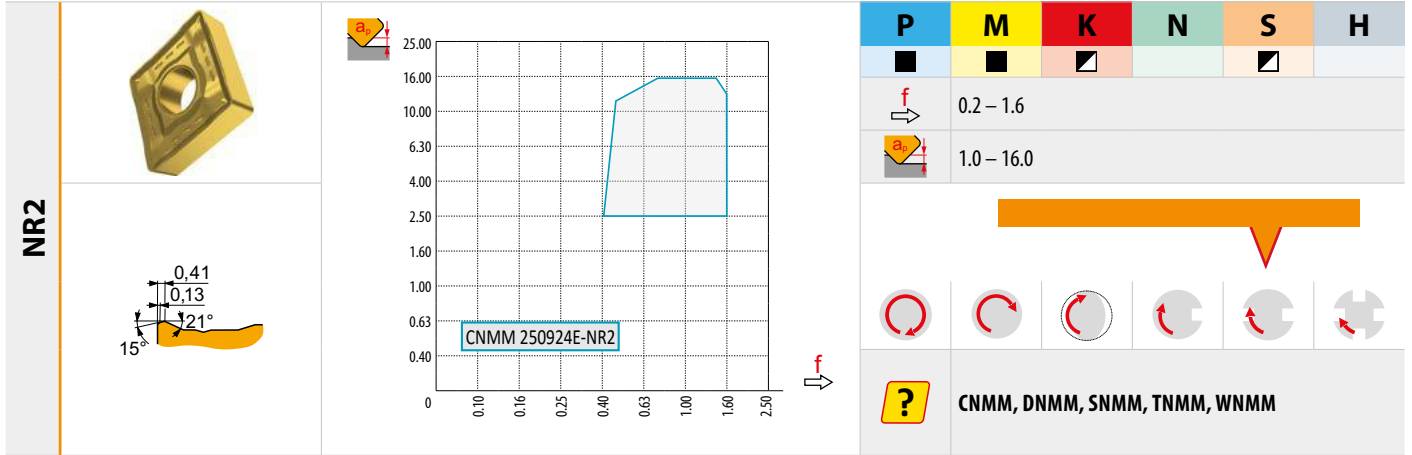



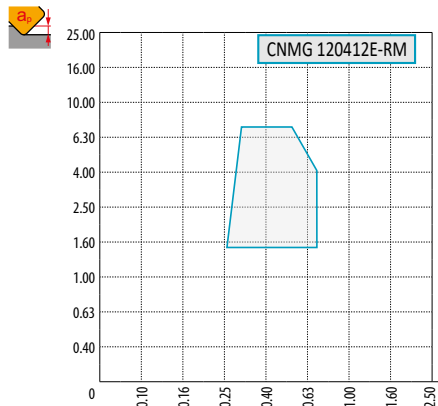
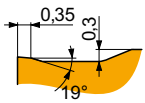



? CNMG, CNMM, SNMG, SNMM



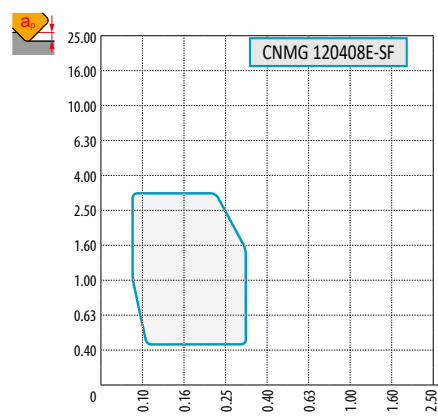
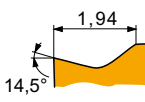



KESME GEOMETRİSİ NEGATİF KESİCİ UÇLAR – İSO P, M, D BAĞLAMA İŞARETİ



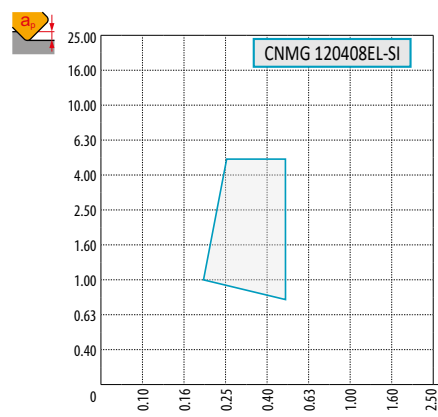
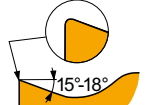



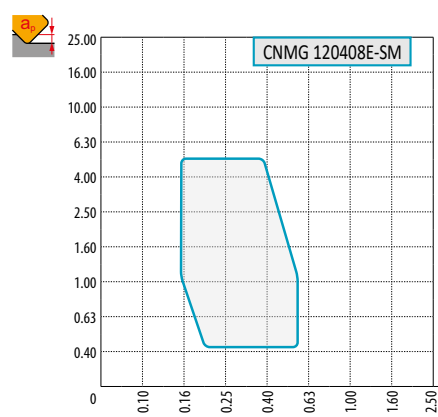
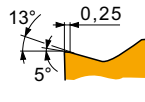

KESME GEOMETRİSİ NEGATİF KESİCİ UÇLAR – İSO P, M, D BAĞLAMA İŞARETİ

RM			P	M	K	N	S	H	
				0.20 – 1.20					
				1.0 – 15.0					
									
									
			 CNMG, DNMG, SNMG, TNMG, WNMG						

SF			P	M	K	N	S	H	
				0.08 – 0.35					
				0.2 – 3.5					
									
									
			 CNMG, DNMG, SNMG, TNMG, VNMG, WNMG						

SI			P	M	K	N	S	H	
				0.20 – 0.50					
				0.4 – 5.0					
									
									
			 CNMG, DNMG, TNMG, WNMG						

SM			P	M	K	N	S	H	
				0.15 – 0.55					
				0.4 – 6.0					
									
									
			 CNMG, DNMG, SNMG, TNMG, VNMG, WNMG						

KESME GEOMETRİSİ NEGATİF KESİCİ UÇLAR – İSO P, M, D BAĞLAMA İŞARETİ

SR

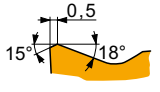
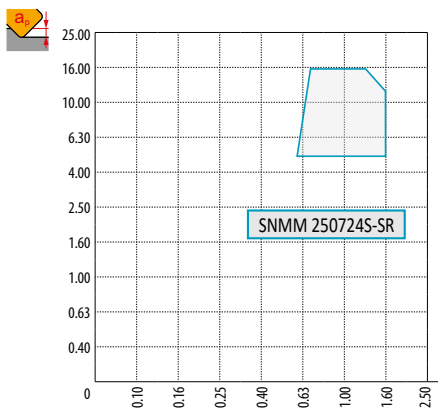



P	M	K	N	S	H
■	▣	■	■	■	■
f	0.70 – 1.60				
a_p	5.0 – 16.0				

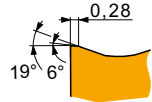
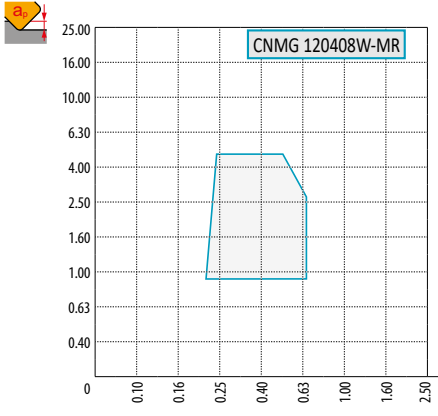

? SNMM, SNMX

W-MR





P	M	K	N	S	H
■	▣	▣	■	■	■
f	0.2 – 0.75				
a_p	0.5 – 5.0				

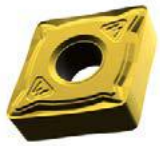
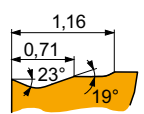
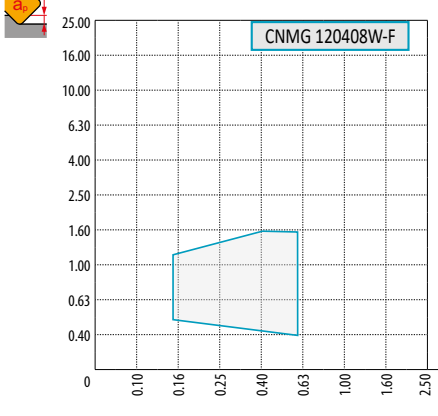

? CNMG, WNMG, DNMG

W-F





P	M	K	N	S	H
■	■	■	■	■	■
f	0.10 – 0.60				
a_p	0.4 – 1.6				

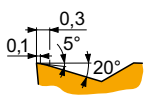
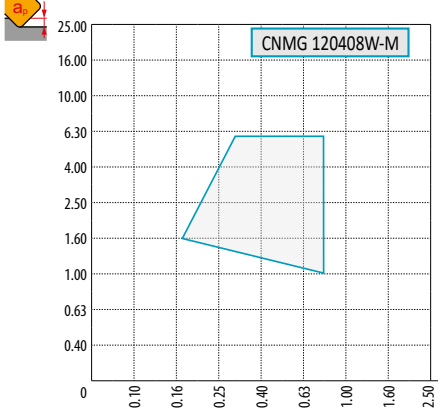

? CNMG, WNMG

W-M

P	M	K	N	S	H
■	■	▣	■	■	■
f	0.15 – 1.00				
a_p	0.8 – 4.0				



? CNMG, WNMG

KESME GEOMETRİSİ NEGATİF KESİCİ UÇLAR – İSO P, M, D BAĞLAMA İŞARETİ

W-NM

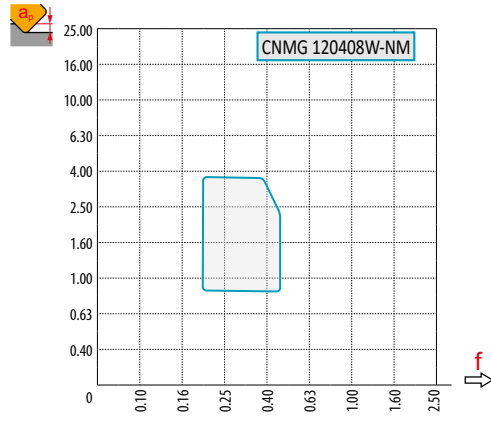
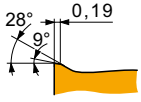

P	M	K	N	S	H
<input type="checkbox"/>	<input checked="" type="checkbox"/>	<input checked="" type="checkbox"/>	<input type="checkbox"/>	<input checked="" type="checkbox"/>	<input type="checkbox"/>
f	0.15 – 0.55				
a_p	0.5 – 3.5				
?	CNMG, DNMX, WNMG				

KESME GEOMETRİSİ NEGATİF KESİCİ UÇLAR – İSO C BAĞLAMA İŞARETİ

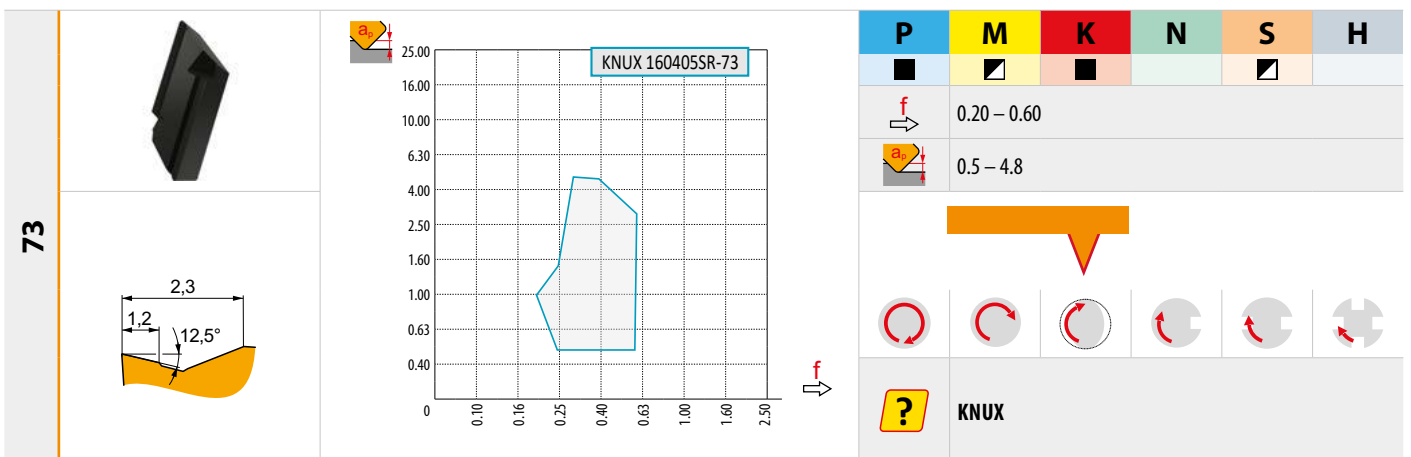
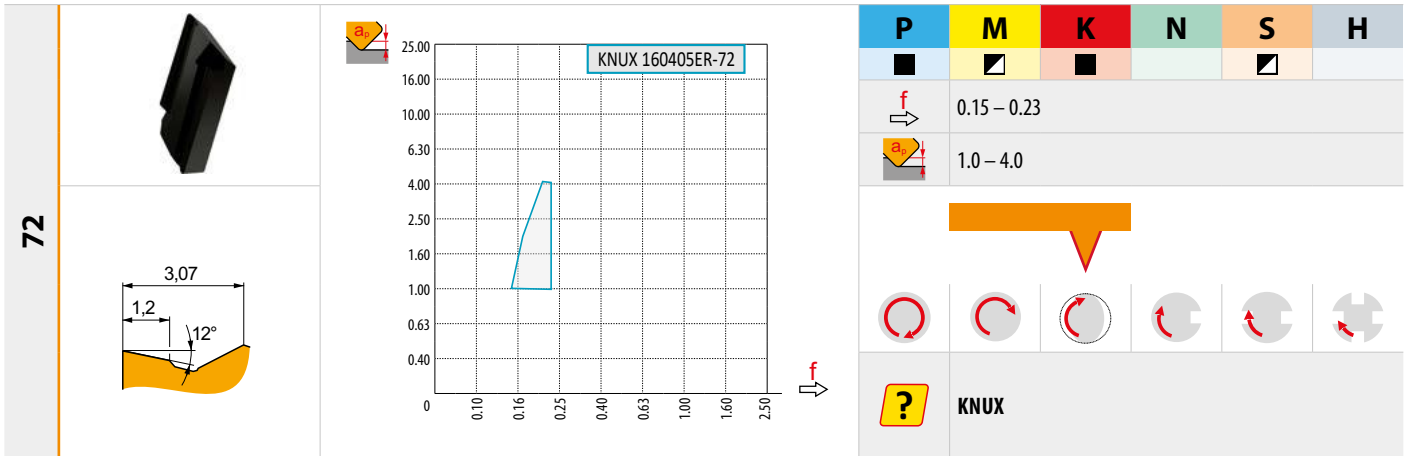
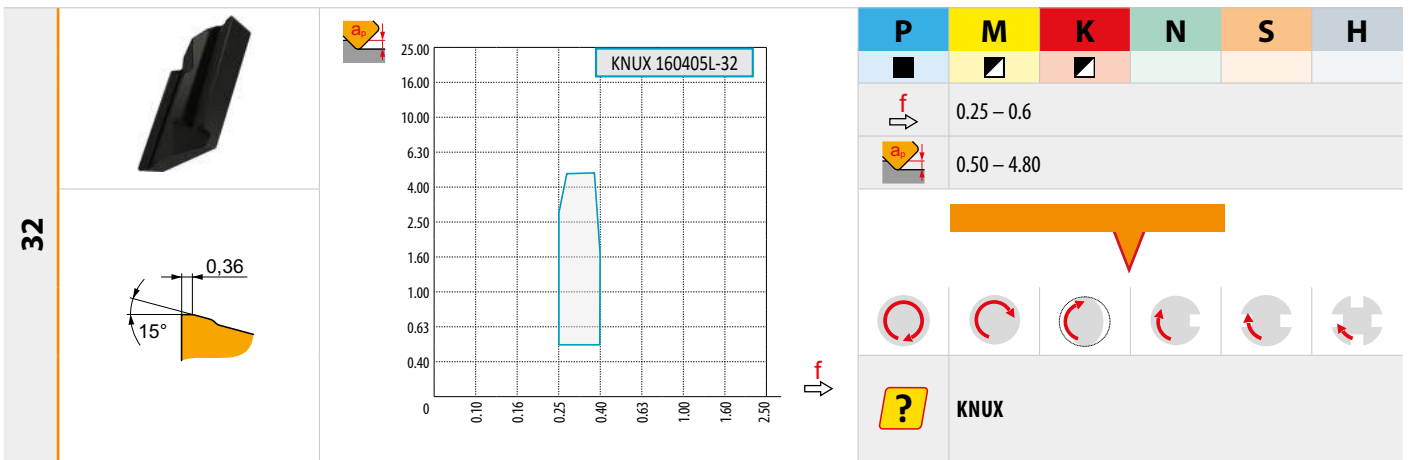
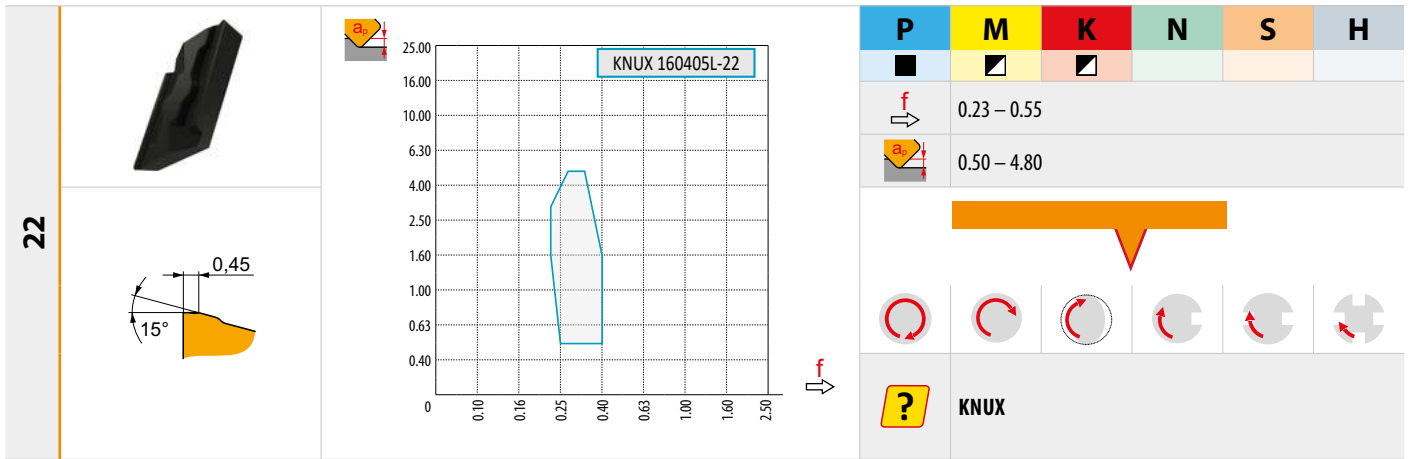

KESME GEOMETRİSİ NEGATİF KESİCİ UÇLAR – İSO C BAĞLAMA İŞARETİ

74

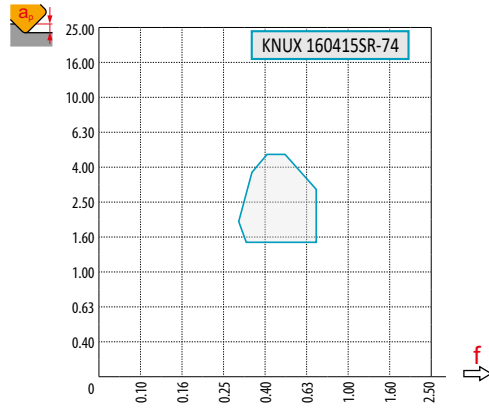
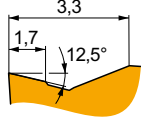

P	M	K	N	S	H
■	▣	■	■	▣	■
f	0.30 – 0.7				
a_p	1.5 – 4.8				
?	KNUX				

KESME GEOMETRİSİ KANAL AÇMA UÇLARI – İSO X VE G BAĞLAMA İŞARETİ

GM (GL.D) **NEW**

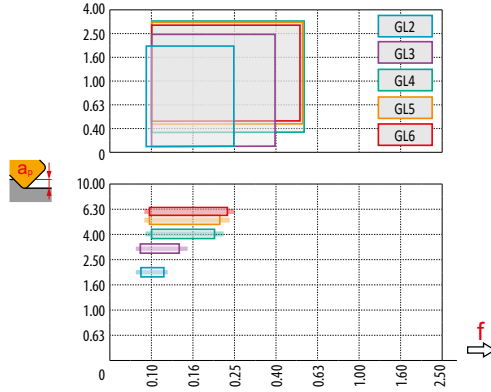

P	M	K	N	S	H
■	■	▣	■	▣	■
f ↓					
a _p ↓					
Bkz. şema					
↓					
↻	↻	↻	↻	↻	↻
?	GL. D				

MM (GL.D) **NEW**

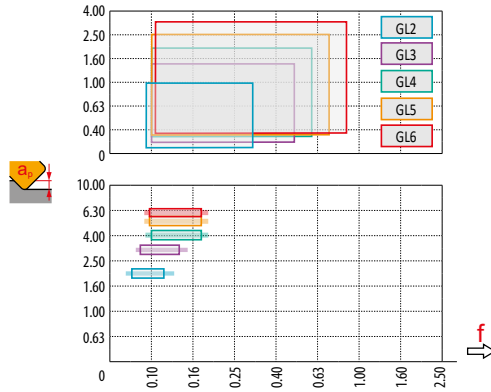

P	M	K	N	S	H
■	■	■	■	▣	■
f ↓					
a _p ↓					
Bkz. şema					
↓					
↻	↻	↻	↻	↻	↻
?	GL. D				

PM (GL.D) **NEW**

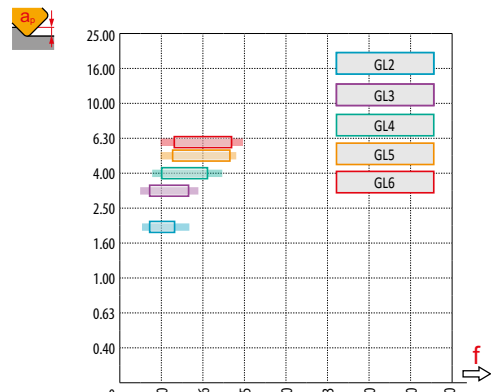

P	M	K	N	S	H
■	■	▣	■	▣	■
f ↓					
a _p ↓					
Bkz. şema					
↓					
↻	↻	↻	↻	↻	↻
?	GL. D				

PR (GL.D) **NEW**

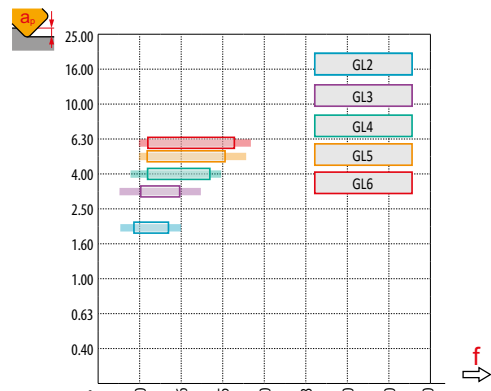

P	M	K	N	S	H
■	▣	■	■	■	■
f ↓					
a _p ↓					
Bkz. şema					
↓					
↻	↻	↻	↻	↻	↻
?	GL. D				

KESME GEOMETRİSİ KANAL AÇMA UÇLARI – İSO X VE G BAĞLAMA İŞARETİ

13 CM (LCMF)

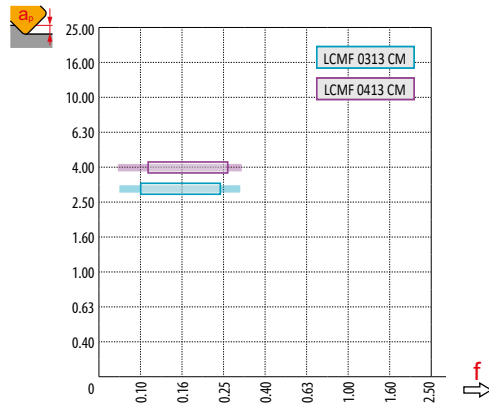
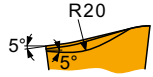

P	M	K	N	S	H
■		▣			
f	Bkz. şema				
a	Bkz. şema				
?	LCMF 13 CM				

13 F (LCM.)

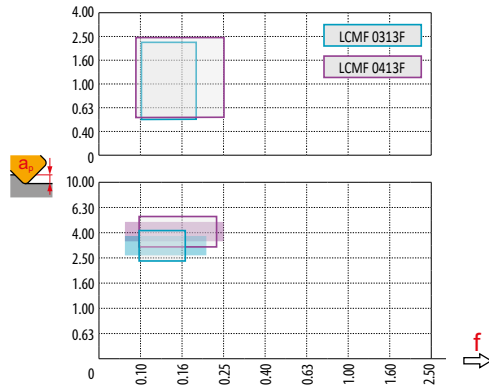
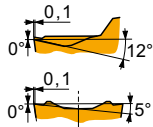

P	M	K	N	S	H
■		▣			
f	Bkz. şema				
a	Bkz. şema				
?	LCMF 13 F, LCMR 13 F				

13 MP (LCM.)

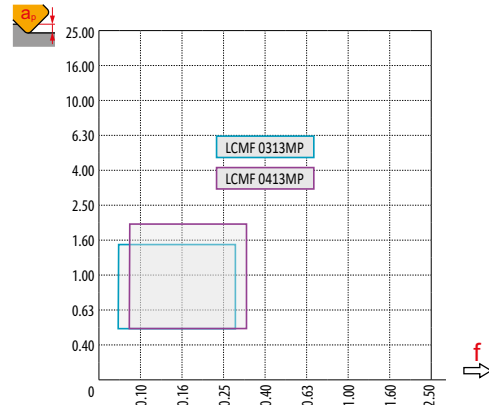
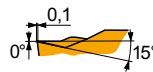

P	M	K	N	S	H
■		■			
f	Bkz. şema				
a	Bkz. şema				
?	LCMF 13 MP, LCMR 13 MP				

16 CM (LCM.)

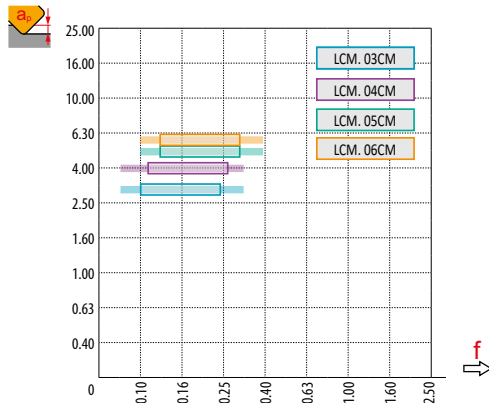

P	M	K	N	S	H
■		▣			
f	Bkz. şema				
a	Bkz. şema				
?	LCMF 16 CM, LCMR 16 CM				

KESME GEOMETRİSİ KANAL AÇMA UÇLARI – İSO X VE G BAĞLAMA İŞARETİ

16 F (LCM.)

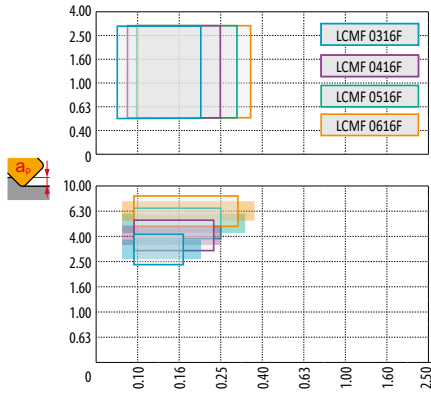
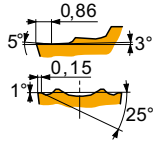

P	M	K	N	S	H
■		■			



Bkz. şema



LCMF 16 F, LCMR 16 F

16 M (LCM.)

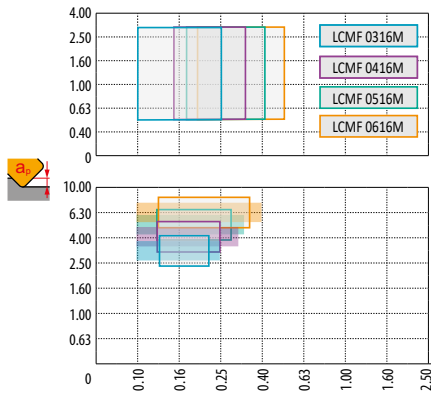
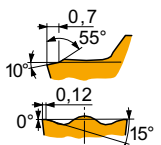
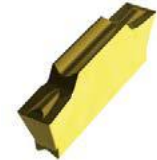

P	M	K	N	S	H
■		■			■



Bkz. şema



LCMF 16 M, LCMR 16 M

16 MP (LCM.)

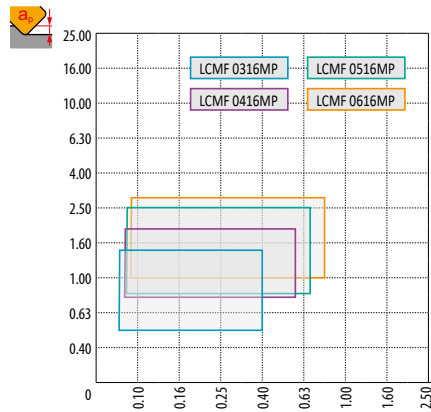

P	M	K	N	S	H
■		■			



Bkz. şema



LCMF 16 MP, LCMR 16 MP

20 F1 (LCMF)

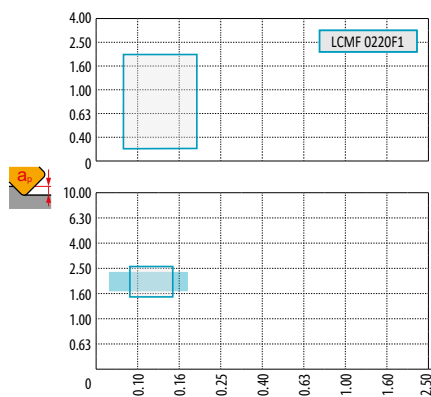
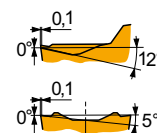

P	M	K	N	S	H
■	■	■			



Bkz. şema



LCMF

KESME GEOMETRİSİ KANAL AÇMA UÇLARI – İSO X VE G BAĞLAMA İŞARETİ

20 M2 (LCMF)

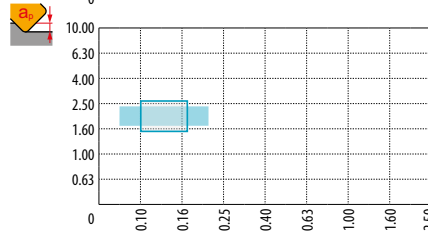
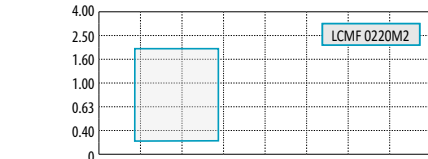
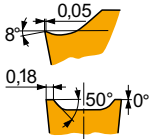

P	M	K	N	S	H
■	▣	▣	■	■	■
f	0.09 – 0.23				
a _p	0.3 – 1.5				



? LCMF

30 F (LCMF)

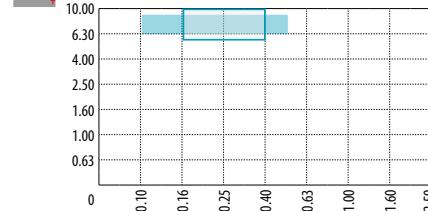
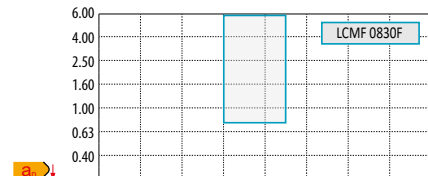
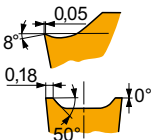

P	M	K	N	S	H
■	▣	▣	■	■	■
f	0.1 – 0.5				
a _p	0.8 – 6.0				



? LCMF 30 F, LCMR 30 F

F1 (LFMX)

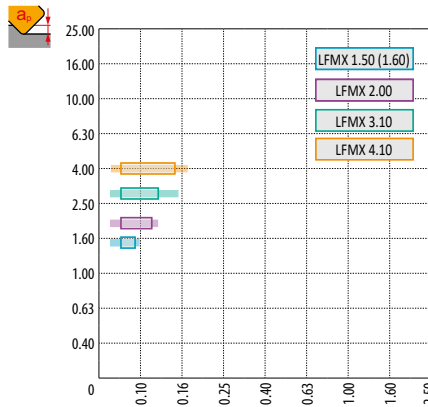
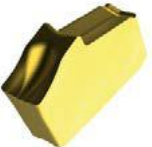

P	M	K	N	S	H
■	▣	▣	■	■	■
f	Bkz. şema				
a _p	Bkz. şema				



? LFMX

F2 (LFMX)

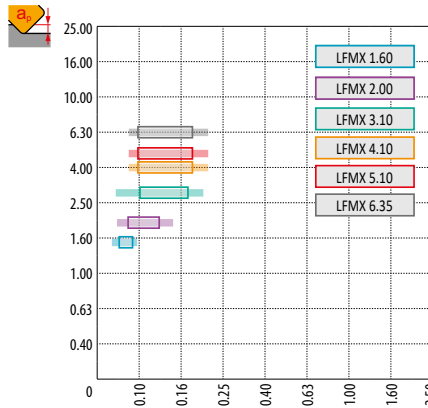
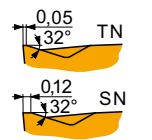

P	M	K	N	S	H
■	▣	▣	■	■	■
f	Bkz. şema				
a _p	Bkz. şema				



? LFMX

KESME GEOMETRİSİ KANAL AÇMA UÇLARI – İSO X VE G BAĞLAMA İŞARETİ

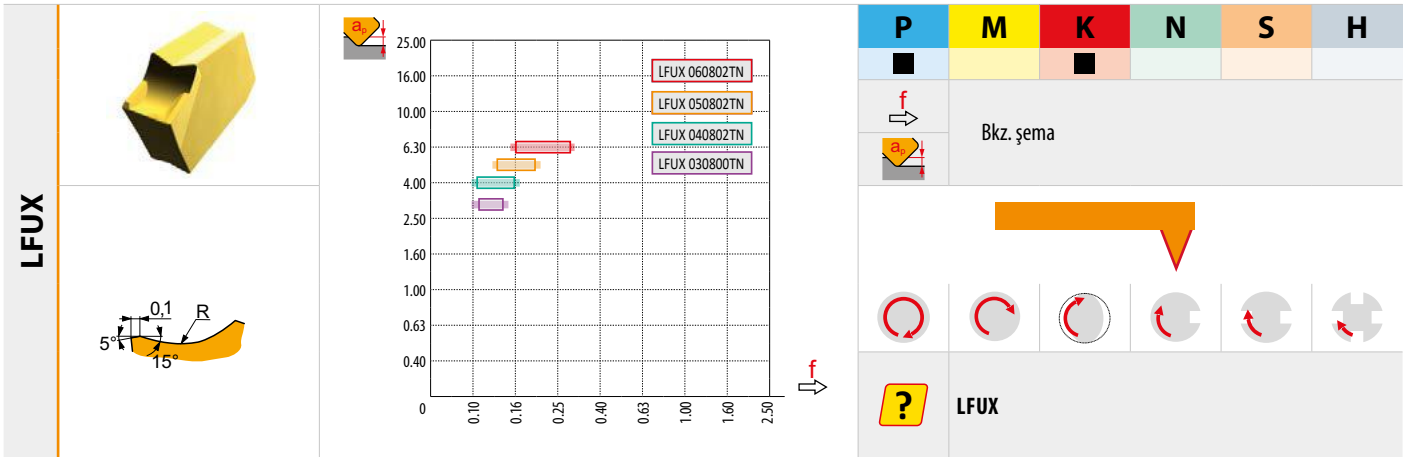
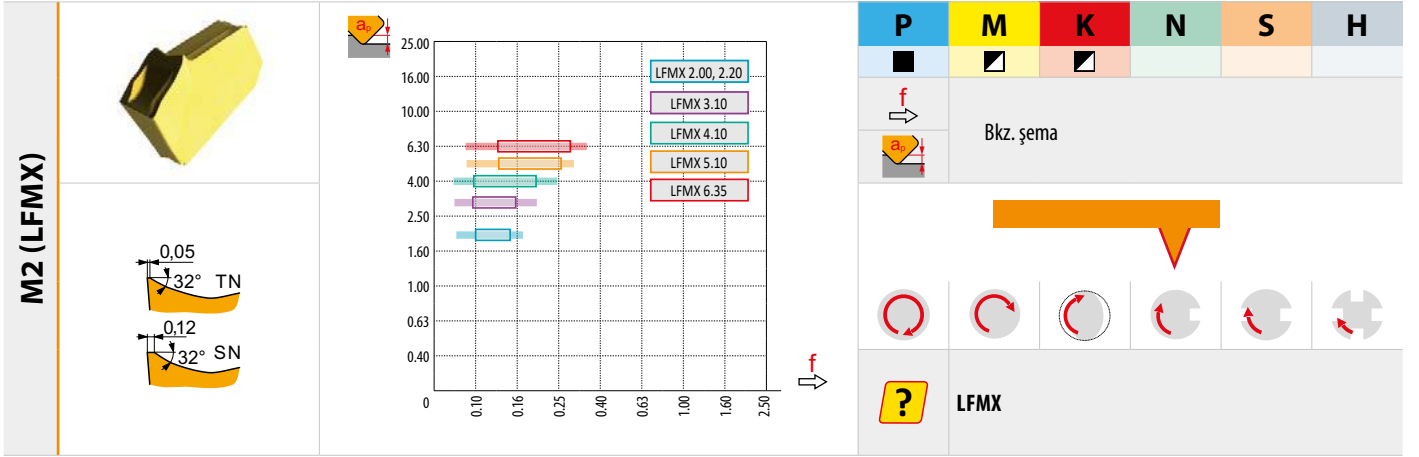

KESME GEOMETRİSİ KANAL AÇMA UÇLARI – İSO S BAĞLAMA İŞARETİ

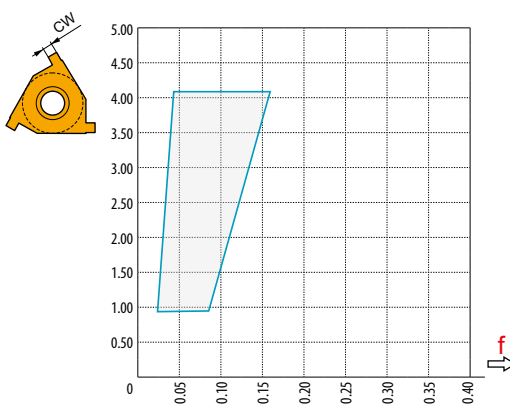

TN. EXT

P	M	K	N	S	H
■	▣	▣	■	■	■

f
CW

Bkz. şema

? TN R EXT; TN ZZ EXT

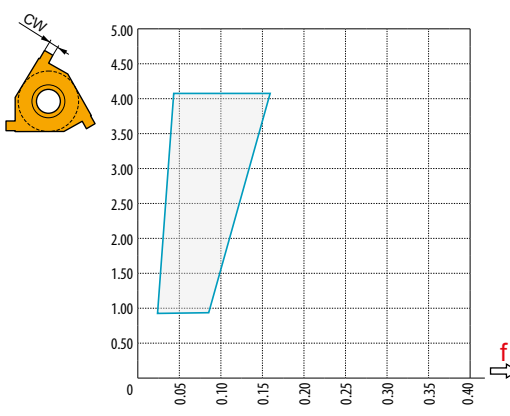

TN. INT

P	M	K	N	S	H
■	▣	▣	■	■	■

f
CW

Bkz. şema

? TN R INT; TN ZZ INT

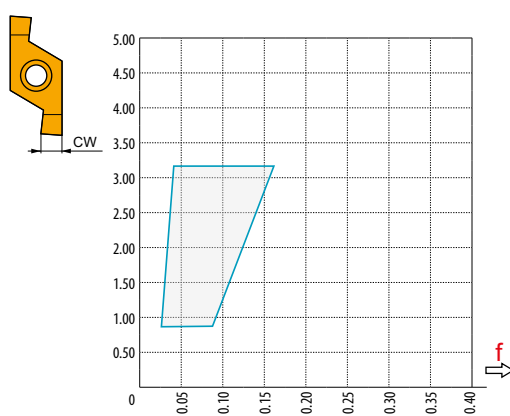

X61 NEW

P	M	K	N	S	H
■	▣	▣	■	■	■

f
CW

Bkz. şema

? X61; X61-1

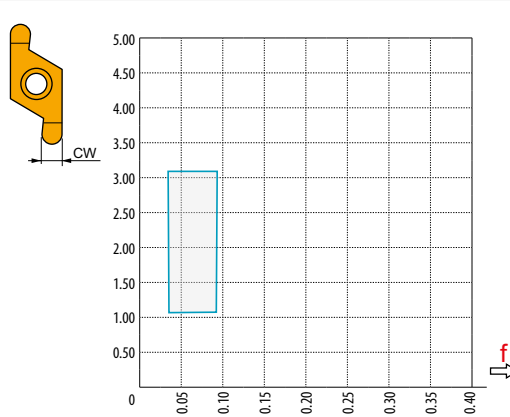

X61 R NEW

P	M	K	N	S	H
■	▣	▣	■	■	■

f
CW

Bkz. şema

? X61 R; X61 R-1

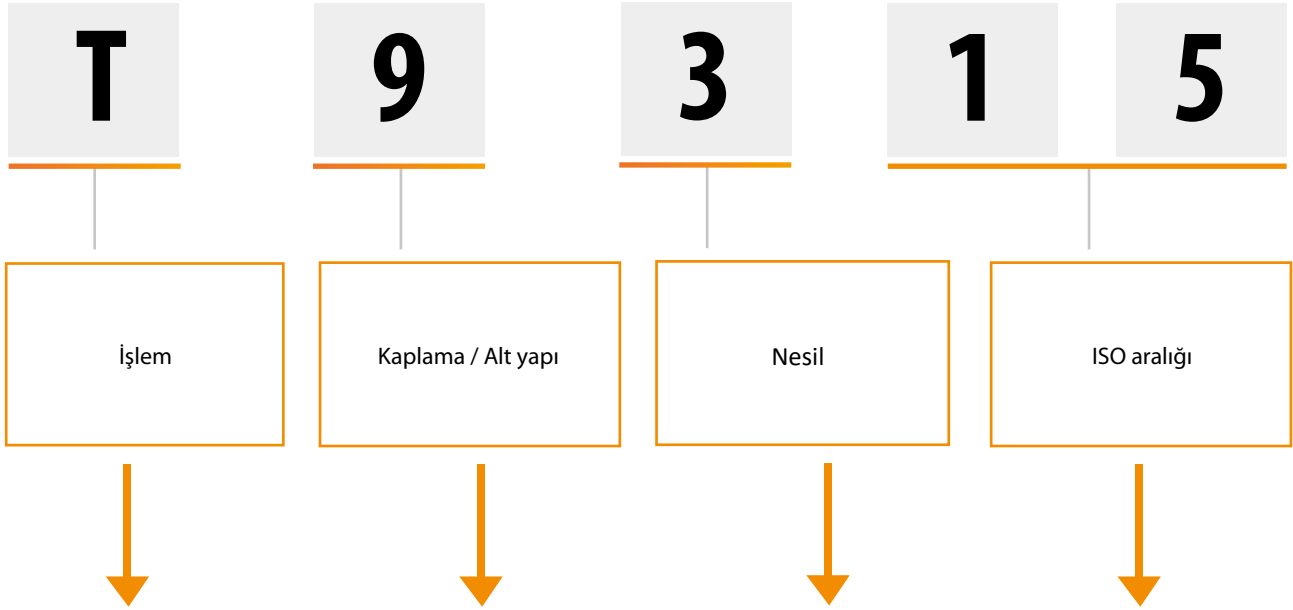

D	Delik delme	0 PVD 1 CVD	Özel uygulama	1 - 9	01 - 50	
M	Frezeleme	2 PVD 3 CVD	Boş			01 - 05
T	Tornalama	4 PVD 5 CVD	K, H grubu		05 - 10	
G	Kanal açma ve Dilimleme	6 PVD 7 CVD	M,S grubu		10 - 20	
		8 PVD 9 CVD	Üniversal		20 - 30	
		B	CBN		30 - 40	
		C	Seramik		40 - 50	
		D	PCD			
		T	Sermet			

TORNALAMA KALİTELERİ

Kalite Tanımlama	Uygulama Alanı	Uygulama	İlerleme	Kesme hızı	Olumsuz Çalışma Koşullarına Direnç	Kaplama	Renk	Altyapı	Kesme sıvısı avantajı	Kalite açıklaması
T9226	P15 - P35	■				MT-CVD	■	FGM	+++	Ağır kaba işleme uygulamaları için tasarlanmış kalitedir. Mekanik hasara karşı yüksek dirençli ve çok iyi aşınma direncini koruyan çok yönlü bir kalitedir. Düşük kesme hızlarında kullanılabilir.
	M10 - M30	■								
	K15 - K35	■								
	S15 - S25	□								
T9310	P01 - P15	■				MT-CVD	■	FGM	++	Hafif darbeli kesimler için kullanılabilen yüksek aşınma direncine sahip kalite. Bu kalite finiş işleme veya yarı kaba işleme operasyonları için kullanılır. Bu malzeme, takım tezgahı-iş parçası konfigürasyonunun yeterince rijit olması koşuluyla kaba işleme operasyonları için de kullanılabilir.
	K05 - K20	■								
	H10 - H20	■								
T9315	P05 - P25	■				MT-CVD	■	FGM	++	Şiddetli kesme koşulları altında bile mükemmel aşınma direnci özelliklerine sahip çok yönlü bir kalite. Darbeli kesimlerin olduğu operasyonlar için de kullanılabilir. Dengeli özellikleriyle bu kalite, çok çeşitli tornalama işlemleri için ilk tercih olabilir. Düşük kesme hızları için uygun değildir.
	K05 - K25	■								
	H10 - H20	■								
T9316	P10 - P20	■				MT-CVD	■	FGM	+++	Demiryolu uygulamaları için tasarlanmış kalitedir. Mükemmel aşınma direncine sahip çok yönlü kalitedir. Düşük ve yüksek kesme hızlarında kullanılabilir.
	M05 - M15	■								
	K10 - K30	■								
T9325	P15 - P35	■				MT-CVD	■	FGM	++	Teknolojik açıdan bakıldığında bu, olumsuz kesme koşullarında mekanik hasara karşı yüksek dirence sahip son derece çok yönlü bir kalitedir ve mükemmel aşınma direncini korur. Bu malzemenin doğru uygulanması için yüksek kesme hızları gerekir.
	M10 - M30	■								
	K15 - K35	■								
T9335	P20 - P45	■				MT-CVD	■	FGM	+++	Orta ila yüksek ilerleme hızlarında ve orta kesme hızlarında özellikle olumsuz kesme koşulları için uygun olan en tok kalitelere biridir. Önceki modellere kıyasla M15 - M40 sadece daha tok değil, aynı zamanda aşınmaya karşı daha dayanıklıdır ve bu özellik yoğun kesme koşullarında avantaj sağlar.
	M15 - M40	■								
	S15 - S25	■								
T7325	P15 - P35	■				MT-CVD	■	FGM	+++	En universal tornalama kalitelerinden biridir. Paslanmaz çelik işleme için özel olarak tasarlanmıştır. Aşınma direnci ve performans güvenilirliği arasında optimum denge sunar. Tornalama işlemlerinde çok çeşitli uygulamalar için uygundur.
	M10 - M25	■								
	S10 - S25	■								
T7335	P20 - P40	■				MT-CVD	■	FGM	+++	Çok yüksek operasyonel güvenilirliğe ve çok iyi aşınma direncine sahip, fonksiyonel bir şekilde derecelendirilmiş altyapısı bulunan kalitedir. En uygun kullanım alanı yüksek tokluğa sahip M20 - M40 malzemelerin işlenmesidir.
	M20 - M40	■								
	S15 - S25	■								
T5305	P05 - P15	■				MT-CVD	■	H	+	Kimyasal aşınmaya karşı çok yüksek dirençli kalitedir; yüksek kesme hızları kullanan finiş işleme operasyonları için uygundur. Ayrıca, yüksek aşınma direnci sayesinde sertleştirilmiş ve işlenmiş K01 - K15 malzemelerin verimli bir şekilde işlenmesi için de uygundur.
	K01 - K15	■								
	H05 - H15	■								
T5315	P10 - P25	■				MT-CVD	■	H	+	Öncelikle verimli işlemeye yönelik, yüksek aşınma direncine ve iyi operasyonel güvenilirliğe sahip kalite. Özellikleri sayesinde bu malzeme iyi veya hafif olumsuz kesme koşullarında kaba ve finiş işleme operasyonları için uygundur.
	K10 - K25	■								
	H15 - H25	■								
6640	P20 - P40	■				MT-CVD	■	H	+++	Özellikle kaba işleme operasyonlarında veya olumsuz kesme koşulları altında operasyonel güvenilirliğin öncelikli olduğu durumlarda kullanılabilen en tok tornalama malzemelerinden biridir. Düşük ila orta kesme hızlarında ve orta ila yüksek ilerleme hızlarında çalışan makineler için diğer bir ideal seçimdir.
	M20 - M35	■								
	K25 - K40	■								

TORNALAMA KALİTELERİ

Kalite Tanımlama	Uygulama Alanı	Uygulama	İlerleme	Kesme hızı	Olumsuz Çalışma Koşullarına Direnç	Kaplama	Renk	Altyapı	Kesme sıvısı avantajı	Kalite açıklaması
G8330	P25 - P40	■				PVD		submicron H	+++	Kanal açma ve dilimleme uygulamaları için üniversal kesme kalitesi. Bu kalitenin karakteristik özellikleri olağanüstü güvenilirlik ve çok yönlülüktür. Çoğu iş parçası malzemesine ait işleme koşullarına uyacak şekilde geliştirilmiştir.
	M20 - M35	■								
	K20 - K40	■								
	S15 - S25	■								
T0315	N05 - N20	■				PVD		submicron H	++	Demir dışı metalleri ve alaşımlarını dengeli bir aşınma direnci ve tokluk oranıyla tormalamak için mikron altı kalitedir. Mükemmel sürtünme özelliklerine sahip benzersiz bir kaplama ile sunulur.
T6310	P01 - P15	■				PVD		ultra submicron H	+++	Üstü PVD kaplamalı, yüksek aşınmaya dayanıklı tormalama kalitesidir. Keskin kesme kenarı ve yüksek yanak aşınma direncinin çok önemli olduğu finiş işleme operasyonları ve uygulamaları için uygundur
	M01 - M15	■								
	K05 - K20	■								
	N05 - N20	■								
	S01 - S15	■								
	H01 - H15	■								
T8010	P05 - P15	■				PVD		submicron H	+++	Bu kalite çelik, paslanmaz çelik, dökme demir ve süper alaşımlarda sürekli yüksek hassasiyetli diş tormalama işlemleri için uygundur. Operasyonel güvenilirlik ve mükemmel aşınma direnci sunar
	M05 - M15	■								
	K10 - K20	■								
	S10 - S15	■								
T8030	P25 - P40	■				PVD		submicron H	+++	Kesinlikle en iyi çok yönlü kalitedir, her tür malzemeyi işlemek için uygundur ve hemen tüm tormalama işlemlerinde uygulanabilir. Başlıca avantajları yüksek operasyonel güvenilirlik ve mükemmel sürtünme özellikleridir; bu nedenle orta ila düşük kesme hızlarındaki uygulamalar için uygundur.
	M20 - M35	■								
	K20 - K40	■								
	N15 - N30	■								
	S15 - S25	■								
T8315	P05 - P20	■				PVD		submicron H	++	Ortalamanın üzerinde operasyonel güvenilirliği korurken mükemmel aşınma direncine sahip kalitedir ve kısa talaşlı sert malzemelerde orta ila yüksek kesme hızlarında işleme için uygundur.
	M05 - M20	■								
	K05 - K25	■								
	N05 - N25	■								
	S05 - S15	■								
	H05 - H15	■								
T8330	P25 - P40	■				PVD		submicron H	+++	Çok yönlülük açısından kuşkusuz en güçlü kesme malzemesi olan bu kalite tüm işlenmiş malzemelerin işlenmesinde kullanılır ve hemen her tür tormalama işleminde pratik olarak uygulanabilir. Başlıca avantajları yüksek operasyonel güvenilirlik ve çok iyi sürtünme özellikleridir; bu nedenle orta ve düşük kesme hızlarındaki uygulamalar için uygundur.
	M20 - M35	■								
	K20 - K40	■								
	N15 - N30	■								
	S15 - S25	■								
	H15 - H25	■								
T8430 NEW	P20 - P40	■				PVD		submicron H	+++	Çok yönlülük açısından kuşkusuz en güçlü kesme malzemesi olan bu kalite tüm işlenmiş malzemelerin işlenmesinde kullanılır ve hemen her tür tormalama işleminde pratik olarak uygulanabilir. Başlıca avantajları yüksek operasyonel güvenilirlik ve çok iyi sürtünme özellikleridir; bu nedenle orta ve düşük kesme hızlarındaki uygulamalar için uygundur.
	M20 - M35	■								
	K25 - K40	■								
	N15 - N30	■								
	S15 - S25	■								
	H15 - H25	■								
T8345	P30 - P50	■				PVD		submicron H	+++	Bu kalite, en tok tormalama kalitesidir ve esas olarak en kötü kesme koşullarında ve en yüksek çalışma güvenilirliği gereksinimleri olan uygulamalarda işleme için tasarlanmıştır. Bu özelliklerinden dolayı bu malzeme daha düşük kesme hızları için tavsiye edilir.
	M20 - M40	■								
	K30 - K40	■								
	S20 - S30	■								
HF7	M10 - M20	■				×		submicron H	++	Esas olarak demir dışı metallerin işlenmesi için tasarlanmış kaplamasız kalitedir; ancak diğer işlenmiş malzemeler için de kullanılabilir (çelik hariç). Bu malzeme tormalama, frezeleme ve hatta delik işleminde kullanılabilir.
	K10 - K25	■								
	N10 - N25	■								

TORNALAMA KALİTELERİ

Kalite Tanımlama	Uygulama Alanı	Uygulama	İlerleme	Kesme hızı	Olumsuz Çalışma Koşullarına Direnç	Kaplama	Renk	Altyapı	Kesme sıvısı avantajı	Kalite açıklaması
H07	M05 - M15	■				×		submicron H	++	Oksidasyon direncinin takım ömrü açısından baskın kriter olmadığı işleme uygulamalarında kullanılan kaplamasız tornalama kalitesidir. Ti bazlı alaşımların işlenmesi için tasarlanmıştır. Kalite, iyi aşınma direnci ile birlikte yüksek kesme kenarı mukavemeti sergiler.
	K10 - K25	■								
	N10 - N30	■								
	S01 - S20	■								
TT310	P10 - P25	■				PVD		cermet	+ / -	Karbon ve alaşımlı çeliklerin (paslanmaz dahil) ince ve yüzey tormalanmasında kullanılan kaplamalı sermet. PVD tekniğiyle uygulanan kaplama sayesinde mükemmel sürtünme özellikleri daha da iyileştirilmiştir.
	M15 - M25	■								
TT010	P01 - P10	■				×		cermet	+ / -	Her tür çeliğin (paslanmaz dahil) çok düşük ilerleme hızlarında ince işlenmesi için uygun kaplamasız sermet. Başlıca avantajı, kesme kenarının minimum yarıçapı ve fiziksel ve kimyasal aşınma mekanizmalarına karşı yüksek direncidir.
	M01 - M10	■								
TC100	K01 - K15	■				×		ceramics	--	Dökme demir işleme için seramik kalitesi. Stabil koşullarda yüksek kesme hızıyla işlemeye uygundur.
TB310	K01 - K10	■				×		CBN	--	Sertleştirilmiş malzemelerin işlenmesi için CBN kalitesi. Stabil koşullarda yüksek kesme hızı ve küçük ilerlemelerle işlemeye uygundur.
	S05 - S10	■								
	H01 - H10	■								
PD1	N05 - N25	■				×		PCD	-	Demir içermeyen malzemeleri tormalamak için PKD kalitesi. Stabil koşullarda yüksek kesme hızı ve küçük ilerlemelerle işleme için ideal tercihtir.
333TN	P45 - P50	■				PVD		HSS	+++	HSS altyapı ve ince sert PVD kaplamadan oluşan özel kalitedir. Portföydeki en tok kesme kalitesidir. Bu kaliteye sahip kesici uçlar sadece kama oluğu açmak için kullanılır.
	M35 - M40	■								
	K35 - K40	■								

Alt yapı	
H	WC-Co bazlı alt yapı
submicron H	İnce tanecikli (< 1 µm) WC-Co bazlı alt yapı
ultra submicron H	Çok ince tanecikli (< 0,5 µm) WC-Co bazlı alt yapı
FGM	İşlevsel kaliteli alt yapı
Cermet	WC'süz sement karbür
ceramics	Seramik
PCD	Polikristal Elmas
CBN	Küçük Boron Nitrür
HSS	Yüksek hız çeliği

Kaplama	
MT-CVD	Orta sıcaklıkta kimyasal kaplama
PVD	Düşük sıcaklıkta fiziksel kaplama
×	Kaplamasız kalite

Kesme sıvısının avantajları	
+++	Kesme sıvısı kullanımı esastır
++	Önemle tavsiye edilir
+	Tavsiye edilir
+ / -	İsteğe bağlı
--	Kesme sıvısı kullanmayın
-	Kesme sıvısı tavsiye edilmez

SERAMİK KESİCİ UÇLAR VE PRATİK UYGULAMALARI

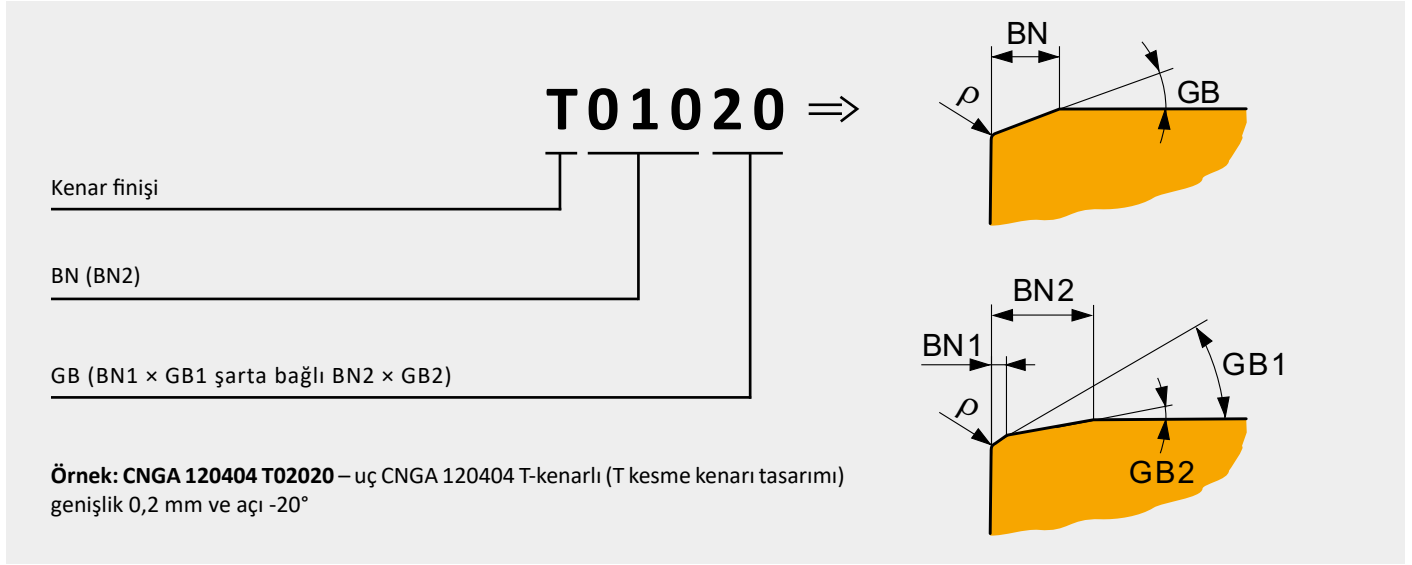

Seramik kesici uçlar en yüksek ısıl kararlılığa sahip malzemelerden biridir. Pratik uygulamaları sırasında iş malzemesi sertliğine ve diğer karakteristiklerine bağlı olarak kesme hızının düşürülmesi zorunludur.

Somut örnekleme amacı ile finiş tornalamada kullanılan yuvarlak uç örneği verilmiştir.

Kesme hızı RNGN ($a_p = 1.5 \text{ mm}$)

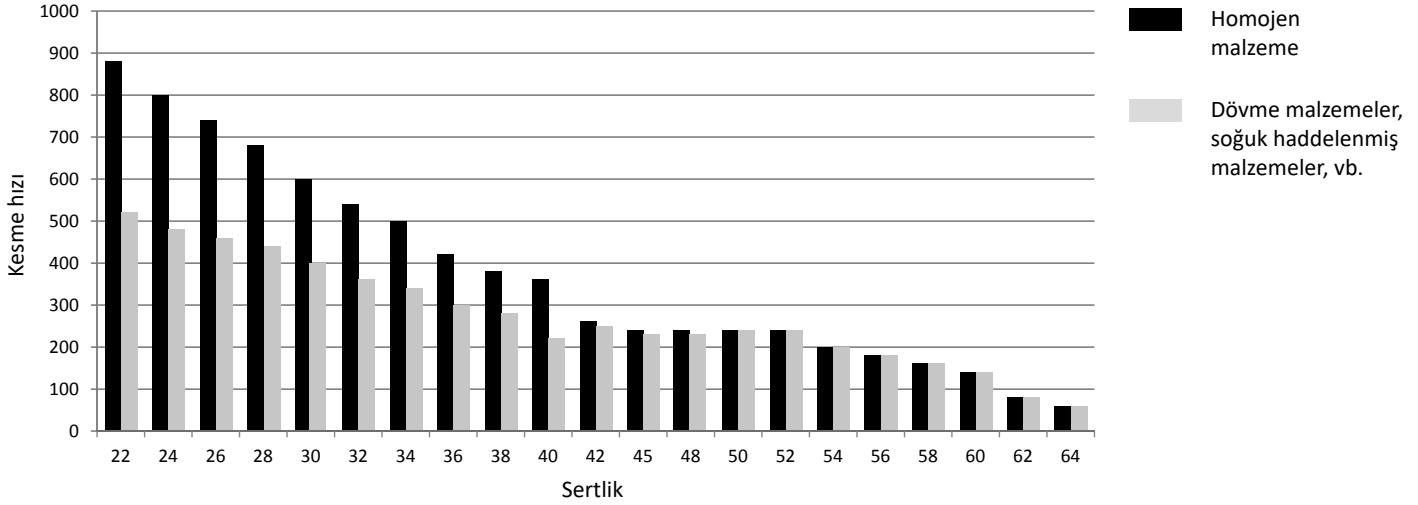

Aşağıdaki tabloda kullanılacak kesme hızı seçiminde dikkate alınması gereken diğer parametreler belirtilmiştir.

Köşe yarıçapı RE [mm]	0.4	0.8	1.2	1.6	2.4	3
v_c azalması	20 %	16 %	12 %	10 %	5 %	2 %
Ana kesme kenarı açısı	90°	75°	60°	45°	30°	< 15°
v_c azalması	0 %	5 %	8 %	12 %	15 %	18 %
Kesici uç şekli	V	D	T	C, W	S	R
Köşe açısı	35°	55°	60°	80°	90°	–
v_c azalması	17 %	12 %	10 %	6 %	4 %	0 %
a_p [mm] kesme derinliği	<1.4	3	6	10	13	20
v_c azalması	5 %	8 %	13 %	16 %	18 %	20 %

SERAMİK KESİCİ UÇLAR VE PRATİK UYGULAMALARI

Daha önce belirtildiği gibi seramik kesici uçlar en yüksek aşınma direncine sahip malzemelerden biridir, ayrıca en düşük mukavemete sahip

malzemelerden biridir. Bu nedenle doğru uç seçiminde ayrıca hesaba katılması gereken en önemli özellik rijitliktir.

Uç şekline bağlı rijitlik

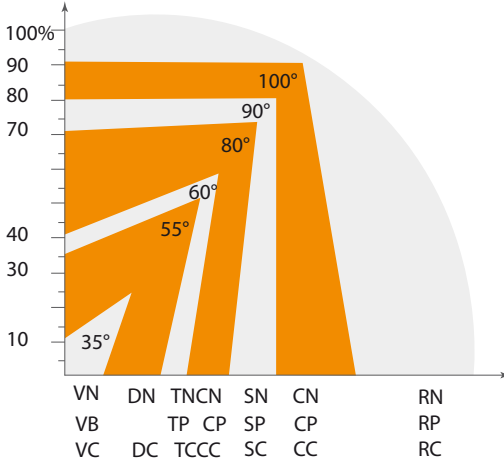

Uç kalınlığına bağlı rijitlik

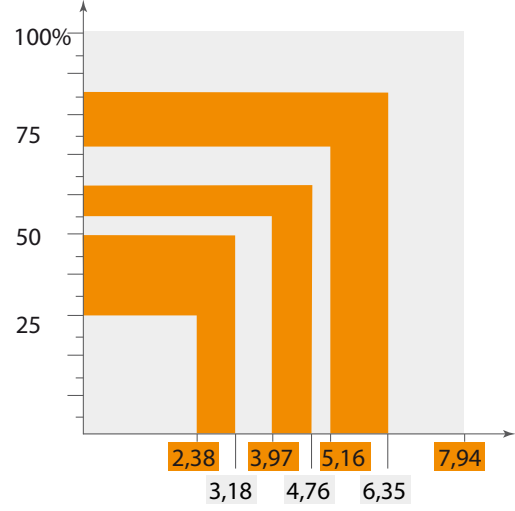

Uç radiusuna bağlı rijitlik

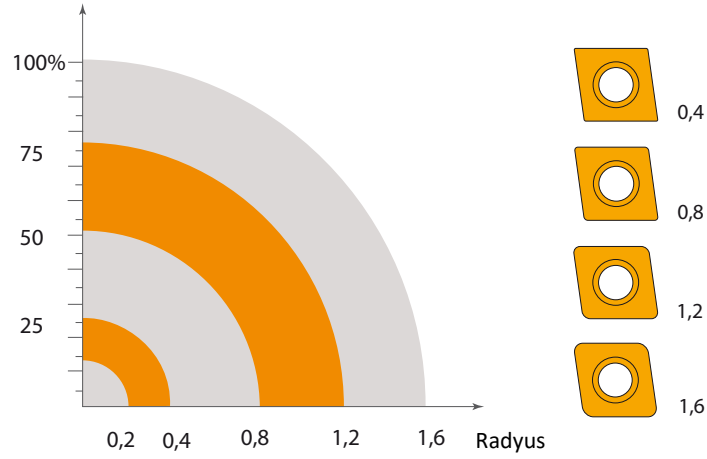

SERAMİK KESİCİ UÇLAR VE PRATİK UYGULAMALARI

Pratik tavsiyeler:

1) Takım çıkışındaki çapaklar uç kenarlarına ve tüm ucun hasar almasına neden olabilir. Bu nedenle çapaklanmayı önlemek için köşelere pah kırılması zorunludur.

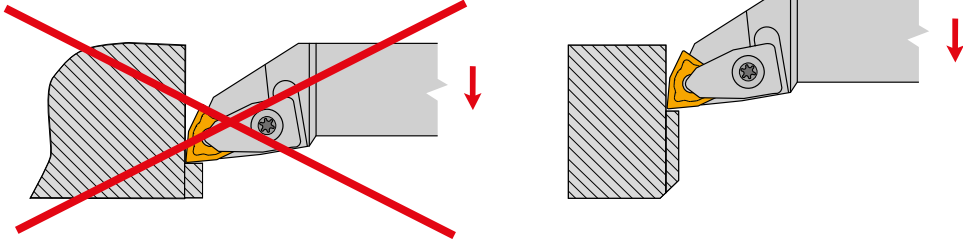

2) Kenarlarda çapak oluşumunu engellemek için standart programın değiştirilmesi tavsiye edilir, böylelikle kenar dayanımı artırılır ve kenarlarda pah kırma gereksinimi kaldırılmış olur.

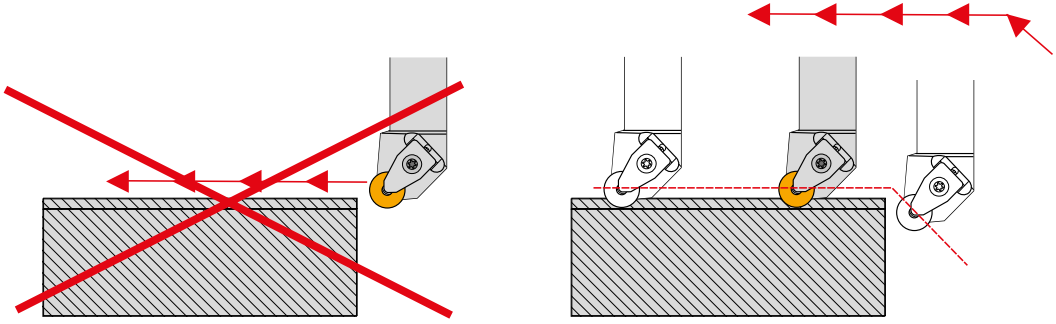

3) Takım vibrasyonu sonucu oluşabilecek riskler mevcut ise, radyal kuvvetlerin ortadan kaldırılması için daha küçük radyuslu uçların kullanılması tavsiye edilir.

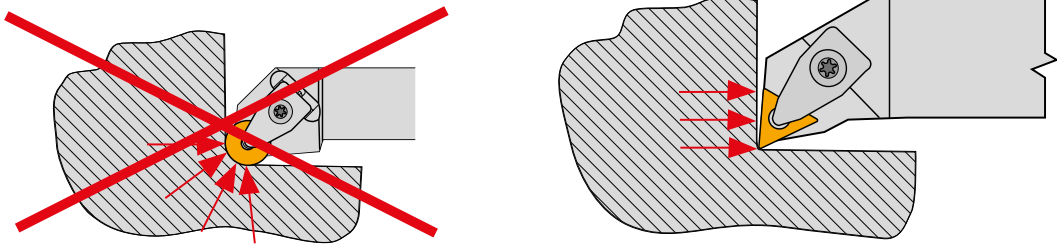

RADYUS VE TUTUCUYA GÖRE X VE Z EKSEN DÜZELTMESİ

Radyus ve tutucuya göre X ve Z eksen düzeltmesi:

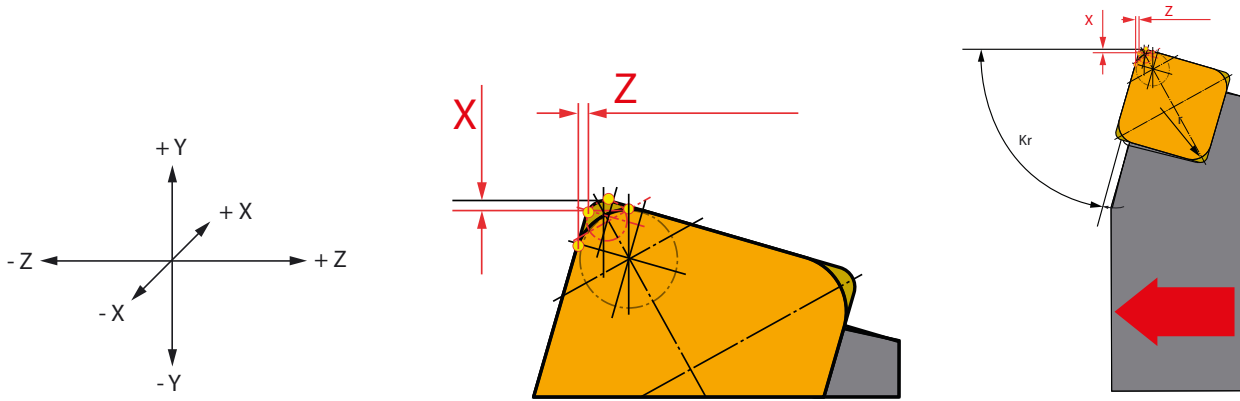

DİKKAT – Belirtilen veriler şekil de gösterilen sağ kesme yönlü tutucular ile uyumludur. İç çap takımları , sol kesme yönlü tutucular ve ya diğer yönlü takımlar için +/- (temsili X/Z değerleri) işaretleri veya düzeltme yapılması gereklidir.

Tutucu		Koordinatlar	Radyus 0,5	Radyus 1,0	Radyus 1,5				
Dış çap	CKJNR/L	x	0.443	0.000	-0.433				
		z	-0.050	0.000	0.050				

Tutucu		Koordinatlar	Radyus 02	Radyus 04	Radyus 08	Radyus 12	Radyus 16	Radyus 24	Radyus 32
Dış çap	DCLNR/L	x	0.060	0.040	0.000	-0.040	-0.080	-0.160	-0.240
		z	-0.062	-0.042	0.000	0.042	0.083	0.166	0.249
	DDJNR/L	x	0.516	0.347	0.000	-0.329	-0.667	-1.343	-2.019
		z	-0.056	-0.041	0.000	0.022	0.054	0.117	0.180
	DSBNR/L	x	0.252	0.170	0.000	-0.158	-0.322	-0.649	-0.977
		z	0.422	0.280	0.000	-0.285	-0.568	-1.134	-1.700
	DSDNN	x	0.000	0.000	0.000	0.000	0.000	0.000	0.000
		z	0.247	0.165	0.000	-0.165	-0.33	-0.659	-0.989
	DSKNR/L	x	0.134	0.089	0.000	-0.089	-0.178	-0.358	-0.537
		z	-0.167	-0.111	0.000	0.111	0.222	0.444	0.667
	DSSNR/L	x	0.000	0.000	0.000	0.000	0.000	0.000	0.000
		z	0.245	0.162	0.000	-0.167	-0.322	-0.662	-0.992
	DTFNR/L	x	0.426	0.284	0.000	-0.284	-0.569	-1.137	-1.705
		z	0.029	0.019	0.000	-0.019	-0.04	-0.078	-0.117
	DTGNR/L	x	0.437	0.294	0.000	-0.277	-0.562	-1.133	-1.703
		z	0.000	0.000	0.000	0.000	0.000	0.000	0.000
	DVJNR/L	x	0.063	0.042	0.000	-0.042	-0.084	-0.169	-0.253
		z	1.234	0.823	0.000	-0.823	-1.646	-3.291	-4.937
	DVPNR/L	x	0.79	0.527	0.000	-0.527	-1.054	-2.108	-3.161
		z	0.834	0.554	0.000	-0.554	-1.109	-2.217	-3.326
DWLNR/L	x	0.061	0.044	0.000	-0.026	-0.061	-0.131	-0.200	
	z	-0.063	-0.045	0.000	0.027	0.062	0.134	0.206	

RADYUS VE TUTUCUYA GÖRE X VE Z EKSEN DÜZELTMESİ

Tutucu		Koordinatlar	Radysus 02	Radysus 04	Radysus 08	Radysus 12	Radysus 16	Radysus 24	Radysus 32	
İç Çap	DCLNR/L	x	-0.053	-0.035	0.000	0.035	0.070	0.140	0.210	
		z	-0.060	-0.040	0.000	0.040	0.080	0.159	0.239	
	DDUNR/L	x	-0.512	-0.341	0.000	0.0341	0.683	1.365	2.047	
		z	-0.073	-0.049	0.000	0.049	0.097	0.195	0.292	
	DTFNR/L	x	-0.425	-0.289	0.000	0.254	0.526	1.069	1.613	
		z	0.000	0.000	0.000	0.000	0.000	0.000	0.000	
	DVUNR/L	x	1.254	-0.836	0.000	0.836	1.671	3.343	5.014	
		z	-0.129	-0.086	0.000	0.086	0.172	0.344	0.516	
	DWLNR/L	x	-0.053	-0.035	0.000	0.035	0.07	0.14	0.21	
		z	-0.06	-0.04	0.000	0.04	0.08	0.159	0.239	
	Dış çap	MTJNR/L	x	0.437	0.294	0.000	-0.277	-0.562	-1.133	-1.703
			z	0.000	0.000	0.000	0.000	0.000	0.000	0.000
MVJNR/L		x	1.263	0.847	0.000	-0.819	-1.651	-3.317	-4.982	
		z	-0.075	-0.055	0.000	0.025	0.065	0.146	0.226	
MWLNR/L		x	0.609	0.044	0.000	-0.026	-0.061	-0.131	-0.200	
		z	-0.063	-0.045	0.000	0.027	0.062	0.134	0.206	
PCBNR/L		x	0.045	0.033	0.000	-0.016	-0.040	-0.088	-0.137	
		z	0.128	0.083	0.000	-0.096	-0.185	-0.364	-0.543	
PCKNR/L		x	0.171	0.115	0.000	-0.110	-0.223	-0.448	-0.672	
		z	0.685	0.457	0.000	-0.457	-0.914	-1.827	-2.741	
PCLNR/L		x	0.061	0.044	0.000	-0.026	-0.061	-0.131	-0.200	
		z	-0.063	-0.045	0.000	0.027	0.062	0.134	0.206	
PDJNR/L		x	0.516	0.347	0.000	-0.329	-0.667	-1.343	-2.019	
		z	-0.056	-0.041	0.000	0.022	0.054	0.117	0.180	
PDNNR/L		x	0.699	0.469	0.000	-0.453	-0.915	-1.837	-2.759	
		z	0.524	0.348	0.000	-0.357	-0.710	-1.415	-2.120	
PDXNR/L		x	0.453	0.305	0.000	-0.288	-0.584	-1.177	-1.770	
		z	-0.156	-0.107	0.000	0.088	0.185	0.380	0.575	
PLBNR/L		x	0.137	0.094	0.000	-0.078	-0.163	-0.335	-0.507	
		z	0.153	0.100	0.000	-0.110	-0.220	-0.433	-0.646	
PSBNR/L		x	0.137	0.094	0.000	-0.078	-0.163	-0.335	-0.507	
		z	0.153	0.100	0.000	-0.110	-0.220	-0.433	-0.646	
PSDNN		x	0.252	0.170	0.000	-0.158	-0.322	-0.649	-0.977	
		z	0.422	0.280	0.000	-0.285	-0.568	-1.134	-1.699	
PSKNR/L		x	0.140	0.094	0.000	-0.090	-0.152	-0.366	-0.550	
		z	0.574	0.383	0.000	-0.384	-0.767	-1.533	-2.300	
PSSNR/L		x	0.246	0.164	0.000	-0.164	-0.328	-0.656	-0.983	
		z	0.424	0.283	0.000	-0.283	-0.566	-1.131	-1.697	
PTFNR/L		x	0.000	0.000	0.000	0.000	0.000	0.000	0.000	
		z	-0.411	-0.243	0.000	0.429	0.765	1.437	2.110	
PTGNR/L		x	0.437	0.294	0.000	-0.277	-0.562	-1.133	-1.703	
		z	0.000	0.000	0.000	0.000	0.000	0.000	0.000	
PTTNR/L	x	0.601	0.403	0.000	-0.389	-0.784	-1.575	-2.367		
	z	0.519	0.345	0.000	-0.354	-0.703	-1.401	-2.099		
PWLNR/L	x	0.609	0.044	0.000	-0.026	-0.061	-0.131	-0.200		
	z	-0.063	-0.045	0.000	0.027	0.062	0.134	0.206		
İç Çap	PCLNR/L	x	-0.061	-0.046	0.000	0.012	0.040	0.098	0.156	
		z	-0.062	-0.047	0.000	0.015	0.046	0.160	0.169	
	PDUNR/L	x	-0.500	-0.339	0.000	0.305	0.627	1.271	1.915	
		z	-0.052	-0.040	0.000	0.006	0.029	0.076	0.122	
	PSKNR/L	x	-0.153	-0.097	0.000	0.063	0.143	0.303	0.463	
		z	0.137	0.098	0.000	-0.124	-0.234	-0.456	-0.677	
	PTFNR/L	x	-0.425	-0.289	0.000	0.254	0.526	1.069	1.613	
		z	0.000	0.000	0.000	0.000	0.000	0.000	0.000	
	PWLNR/L	x	-0.060	-0.046	0.000	0.012	0.043	0.098	0.156	
		z	-0.065	-0.049	0.000	0.012	0.040	0.105	0.166	

RADYUS VE TUTUCUYA GÖRE X VE Z EKSEN DÜZELTMESİ

Tutucu		Koordinatlar	Radysus 02	Radysus 04	Radysus 08	Radysus 12	Radysus 16	Radysus 24	Radysus 32
Dış çap	SCACR/L	x	0.115	0.077	0.000	-0.077	-0.153	-0.307	-0.460
		z	0.000	0.000	0.000	0.000	0.000	0.000	0.000
	SCBCR/L	x	0.042	0.028	0.000	-0.028	-0.055	-0.111	-0.166
		z	0.130	0.087	0.000	-0.087	-0.174	-0.347	-0.521
	SCDCR/L	x	0.000	0.000	0.000	0.000	0.000	0.000	0.000
		z	-0.279	-0.186	0.000	0.186	0.372	0.745	1.117
	SCFCR/L	x	0.000	0.000	0.000	0.000	0.000	0.000	0.000
		z	-0.124	-0.083	0.000	0.083	0.166	0.331	0.497
	SCLCR/L	x	0.060	0.040	0.000	-0.040	-0.080	-0.160	-0.240
		z	-0.062	-0.042	0.000	0.042	0.083	0.166	0.249
	SDJCR/L	x	0.520	0.346	0.000	-0.346	-0.693	-1.386	-2.078
		z	-0.060	-0.040	0.000	0.040	0.080	0.161	0.241
	SDNCN	x	0.699	0.466	0.000	-0.466	-0.933	-1.865	-2.798
		z	0.000	0.000	0.000	0.000	0.000	0.000	0.000
	SEGCR/L	x	0.000	0.000	0.000	0.000	0.000	0.000	0.000
		z	-0.182	-0.121	0.000	0.121	0.243	0.485	0.728
	SSBCR/L	x	0.135	0.090	0.000	-0.090	-0.180	-0.360	-0.539
		z	0.155	0.104	0.000	-0.104	-0.207	-0.414	-0.621
	SSDCN	x	0.249	0.166	0.000	-0.166	-0.331	-0.663	-0.994
		z	0.000	0.000	0.000	0.000	0.000	0.000	0.000
	SSKCR/L	x	-0.376	-0.517	0.000	-1.083	-1.366	-1.931	-2.497
		z	-0.135	-0.090	0.000	0.090	0.180	0.360	0.539
	STCFR/L	x	0.000	0.000	0.000	0.000	0.000	0.000	0.000
		z	-	-	0.000	-	-	-	-
	STJCR/L	x	0.406	0.271	0.000	-0.271	-0.542	-1.084	-1.626
		z	-0.054	-0.036	0.000	0.036	0.071	0.143	-0.214
	SVACR/L	x	00 / 0	01 / -0.107	-	-	-	-	-
		z	00 / 0	01 / -0.107	-	-	-	-	-
	SVGCR/L	x	0.000	0.000	0.000	0.000	0.000	0.000	0.000
		z	-1.303	-0.869	0.000	0.869	1.737	3.475	5.212
	SVHBR/L	x	1.034	0.690	0.000	-0.690	-1.379	-2.759	-4.138
		z	-0.544	-0.363	0.000	0.363	0.726	1.452	2.178
	SVHCR/L	x	1.034	0.690	0.000	-0.690	-1.379	-2.759	-4.138
		z	-0.544	-0.363	0.000	0.363	0.726	1.452	2.178
	SVJBR/L	x	1.269	0.846	0.000	-0.846	-1.692	-3.384	-5.076
		z	-0.099	-0.066	0.000	0.066	0.132	0.263	0.395
	SVJCR/L	x	1.269	0.846	0.000	-0.846	-1.692	-3.384	-5.076
		z	-0.099	-0.066	0.000	0.066	0.132	0.263	0.395
	SVPBR/L	x	0.811	0.541	0.000	-0.541	-1.081	-2.162	-3.244
		z	-0.811	-0.541	0.000	0.541	1.081	2.162	3.244
	SVPBR/L	x	0.811	0.541	0.000	-0.541	-1.081	-2.162	-3.244
		z	-0.811	-0.541	0.000	0.541	1.081	2.162	3.244
	SVVBN	x	1.395	0.930	0.000	-0.930	-1.860	-3.721	-5.581
		z	0.000	0.000	0.000	0.000	0.000	0.000	0.000
	SVVCN	x	1.395	0.930	0.000	-0.930	-1.860	-3.721	-5.581
		z	0.000	0.000	0.000	0.000	0.000	0.000	0.000
	SVXBR/L	x	1.201	0.801	0.000	-0.801	-1.601	-3.202	-4.804
		z	-0.259	-0.173	0.000	0.173	0.345	0.691	1.036
	SVXCR/L	x	1.201	0.801	0.000	-0.801	-1.601	-3.202	-4.804
		z	-0.259	-0.173	0.000	0.173	0.345	0.691	1.036
SWLCR/L	x	0.060	0.040	0.000	-0.040	-0.080	-0.160	-0.240	
	z	-0.060	-0.040	0.000	0.040	0.080	0.160	0.240	

RADYUS VE TUTUCUYA GÖRE X VE Z EKSEN DÜZELTMESİ

Tutucu	Koordinatlar	Radysus 02	Radysus 04	Radysus 08	Radysus 12	Radysus 16	Radysus 24	Radysus 32	
İç Çap	SCFCR/L	x	-0.420	-0.280	0.000	0.280	0.560	1.121	1.681
		z	0.000	0.000	0.000	0.000	0.000	0.000	0.000
	SCKCR/L	x	-0.040	-0.027	0.000	0.027	0.054	0.108	0.161
		z	0.130	0.087	0.000	-0.087	-0.174	-0.348	0.521
	SCLCR/L	x	-0.058	-0.039	0.000	0.039	0.078	0.155	0.233
		z	-0.062	-0.042	0.000	0.042	0.083	0.166	0.249
	SCXCR/L	x	-0.178	-0.119	0.000	0.119	0.237	0.474	0.711
		z	0.000	0.000	0.000	0.000	0.000	0.000	0.000
	SDQCR/L	x	-0.309	-0.194	0.000	0.206	0.412	0.825	1.237
		z	-0.310	-0.206	0.000	0.268	0.499	0.961	1.423
	SDUCR/L	x	-0.504	-0.336	0.000	0.336	0.672	1.344	2.016
		z	-0.059	-0.039	0.000	0.041	0.082	0.162	0.242
	SDZCR/L	x	-0.520	-0.346	0.000	0.346	0.693	0.139	2.078
		z	0.059	0.039	0.000	-0.041	-0.082	-0.162	-0.242
	SELPR/L	x	-0.126	-0.084	0.000	0.084	0.168	0.337	0.051
		z	-0.066	-0.044	0.000	0.044	0.088	0.176	0.264
	SEUCR/L	x	-0.149	-0.099	0.000	0.099	0.199	0.397	0.596
		z	-0.041	-0.027	0.000	0.027	0.053	0.107	0.160
	SEUPR/L	x	-0.148	-0.099	0.000	0.099	0.198	0.396	0.593
		z	-0.040	-0.027	0.000	0.027	0.053	0.107	0.160
	SEXPR/L	x	-0.384	-0.256	0.000	0.256	0.512	1.024	1.537
		z	0.000	0.000	0.000	0.000	0.000	0.000	0.000
	SSSCR/L	x	-0.249	-0.166	0.000	0.166	0.331	0.663	0.994
		z	0.000	0.000	0.000	0.000	0.000	0.000	0.000
	STFCR/L	x	-0.433	-0.289	0.000	0.289	0.577	1.154	1.731
		z	0.000	0.000	0.000	0.000	0.000	0.000	0.000
	SVLCR/L	x	-1.243	-0.828	0.000	0.828	1.657	3.314	4.971
		z	0.239	0.692	0.000	-0.108	-0.215	-0.430	-0.645
	SVQBR/L	x	-1.027	-0.684	0.000	0.690	1.369	2.738	4.106
		z	-0.545	-0.363	0.000	0.363	0.726	1.452	2.178
	SVQCR/L	x	-1.027	-0.684	0.000	0.690	1.369	2.738	4.106
		z	-0.545	-0.363	0.000	0.363	0.726	1.452	2.178
	SVUBR/L	x	-1.259	-0.840	0.000	0.840	1.679	3.358	5.037
		z	0.099	-0.066	0.000	0.066	0.132	0.263	0.395
	SVUCR/L	x	-1.259	-0.840	0.000	0.840	1.679	3.358	5.037
		z	0.099	-0.066	0.000	0.066	0.132	0.263	0.395
	SVXCR/L	x	-0.917	-0.611	0.000	0.611	1.222	2.445	3.667
		z	-0.696	-0.464	0.000	0.464	0.928	1.856	2.783
	SWLCR/L	x	-0.060	-0.039	0.000	0.039	0.079	0.158	0.237
		z	-0.060	-0.040	0.000	0.040	0.080	0.160	0.240
SWUCR/L	x	-0.080	-0.053	0.000	0.053	0.107	0.213	0.319	
	z	-0.034	-0.024	0.000	0.024	0.049	0.098	0.146	

DİKKAT – Belirtilen veriler şekil de gösterilen sağ kesme yönlü tutucular ile uyumludur. İç çap takımları , sol kesme yönlü tutucular ve ya diğer yönlü takımlar için +/- (temsili X/Z değerleri) işaretleri veya düzeltme yapılması gereklidir.

DIŞ AÇMA

Üretim yöntemi seçimi iş parçasından ve makineden etkilenir. İş parçası dış veya iç diş, sağ veya sol diş. Makine sağ veya sol yönlü takım. Aşağıdaki Tablo i kullanabilirsiniz.

DIŞ ÇAP DIŞ, SAĞ YÖNLÜ

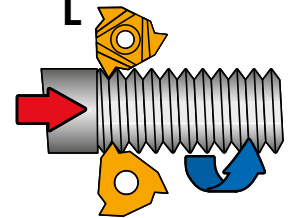
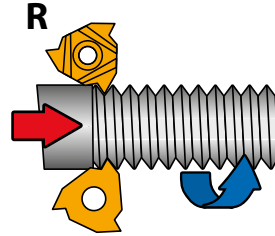
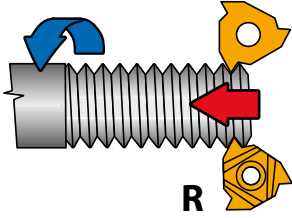

DIŞ ÇAP DIŞ, SOL YÖNLÜ

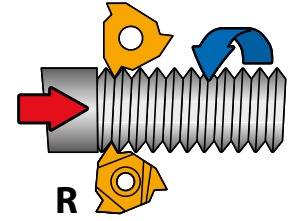
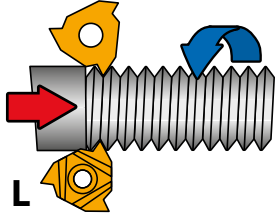
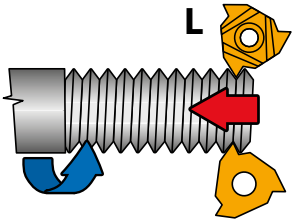

İÇ ÇAP DIŞ, SAĞ YÖNLÜ

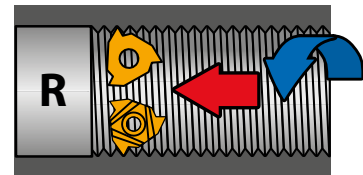
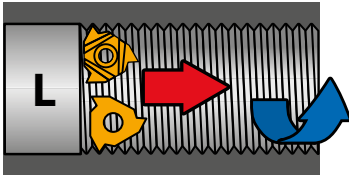

İÇ ÇAP DIŞ, SOL YÖNLÜ

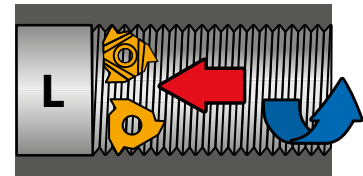
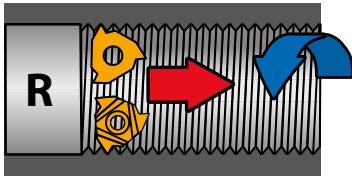

■ İş parçası hareketi

■ Takım hareketi

L / R Uç tasarımı

Helis açısının hesaplanması için aşağıdaki formül kullanılabilir:

$$\operatorname{tg} \omega = \frac{p}{d_s \cdot \pi}$$

ω Helis açısı [°]

p Hatve [mm]

d_s Hatve çapı [mm]

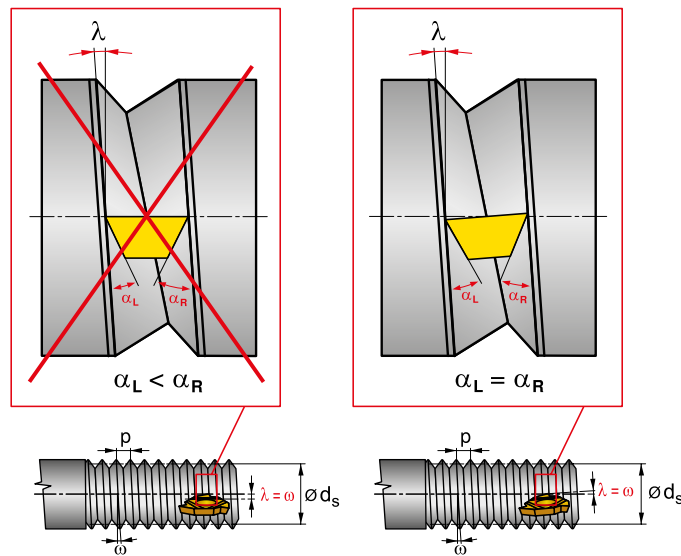

Doğru diş formunu ve uç üzerinde aynı aşınmayı oluşturmak için kesme kenarı helis açısı diş kılavuz açısına eşit olmalıdır. Takım tutucular genellikle helis açısı $\lambda = 1.5^\circ$ olarak temin edilir. Altlık değiştirilerek farklı helis açısı seçilebilir. Doğru altlık seçimi için aşağıdaki Tablo ve ya Şekil Grafik 'i kullanabilirsiniz.

Ayar sacı seçimi

Helis açısı λ	Pozitif					Negatif		Kanal uçları için TN16... ZZ, TN22... ZZ
	4.5°	3.5°	2.5°	1.5°	0.5°	-0.5°	-1.5°	
Tutucu	Altlık tanımı							
SER16; SIL16	PE16+4.5	PE16+3.5	PE16+2.5	PE16+1.5	PE16+0.5	PE16-0.5	PE16-1.5	PE16ZZ
SEL16; SIR16	PI16+4.5	PI16+3.5	PI16+2.5	PI16+1.5	PI16+0.5	PI16-0.5	PI16-1.5	PI16ZZ
SER22; SIL22	PE22+4.5	PE22+3.5	PE22+2.5	PE22+1.5	PE22+0.5	PE22-0.5	PE22-1.5	PE22ZZ
SEL22; SIR22	PI22+4.5	PI22+3.5	PI22+2.5	PI22+1.5	PI22+0.5	PI22-0.5	PI22-1.5	PI22ZZ
SER-S22; SIR-S22	PE22S+4.5	PE22S+3.5	PE22S+2.5	PE22S+1.5	PE22S+0.5	PE22S-0.5	PE22S-1.5	-
SEL-S22; SIR-S22	PI22S+4.5	PI22S+3.5	PI22S+2.5	PI22S+1.5	PI22S+0.5	PI22S-0.5	PI22S-1.5	-

Takım tutucular genellikle helis açısı $\lambda = 1.5^\circ$ olarak temin edilir. Altlık değiştirilerek farklı helis açısı seçilebilir. Doğru altlık seçimi için aşağıdaki Tablo 16 ve ya Şekil Grafik 21'i kullanabilirsiniz. SER-S , SIR-S tutucuları için ayar sacları „S“ ile işaretlenmiştir.

Ayar sacı seçimi için grafik

Diş hatvesi P [mm]

Diş sayısı / 1"

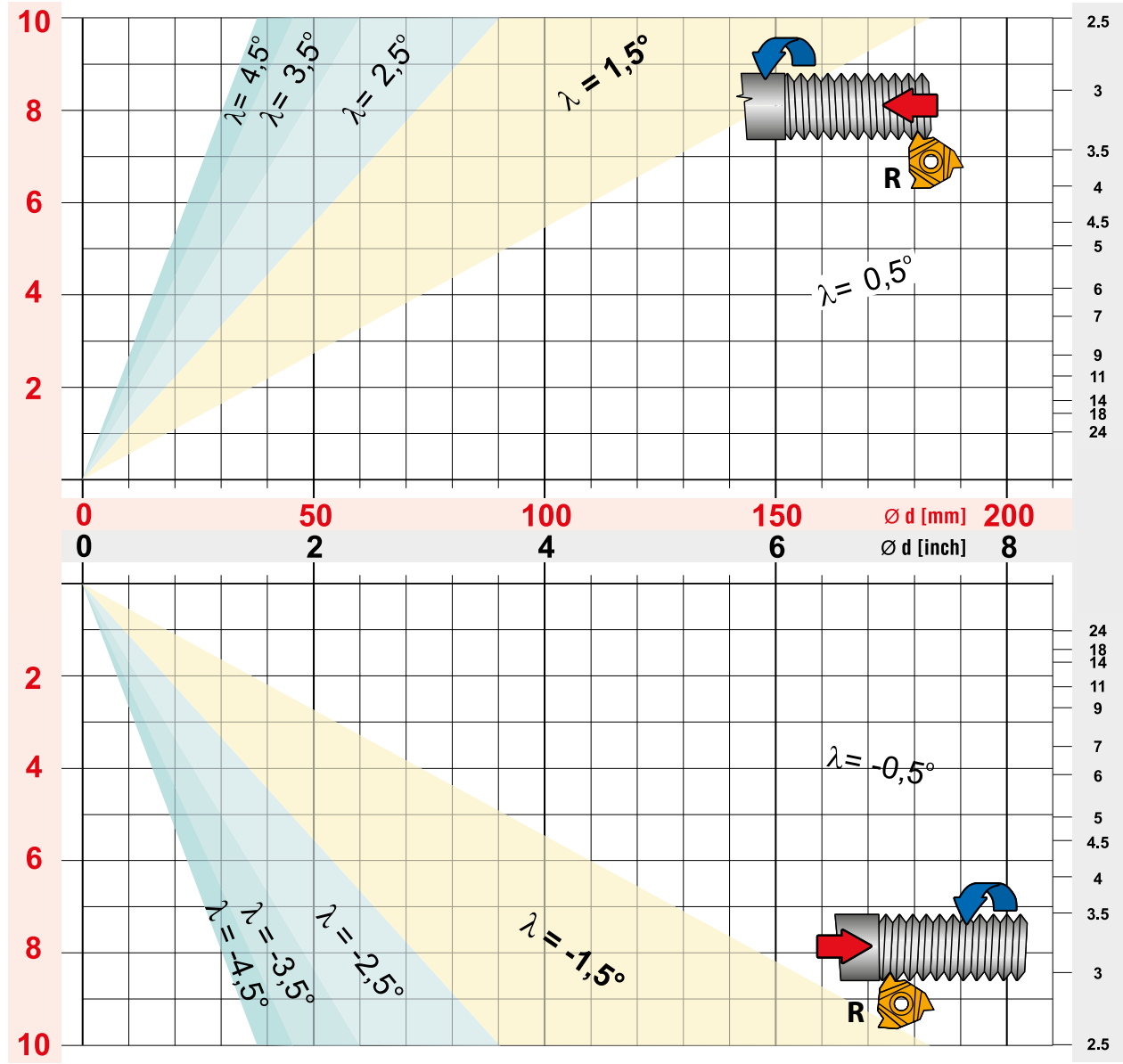

■ İş parçası hareketi

■ Takım hareketi

L / R Uç tasarımı

Besleme yöntemi ve derinliği

Uzun talaş veren malzemeler için iyi talaş kontrolünü sağlamak için besleme yöntemi seçimi çok önemlidir.

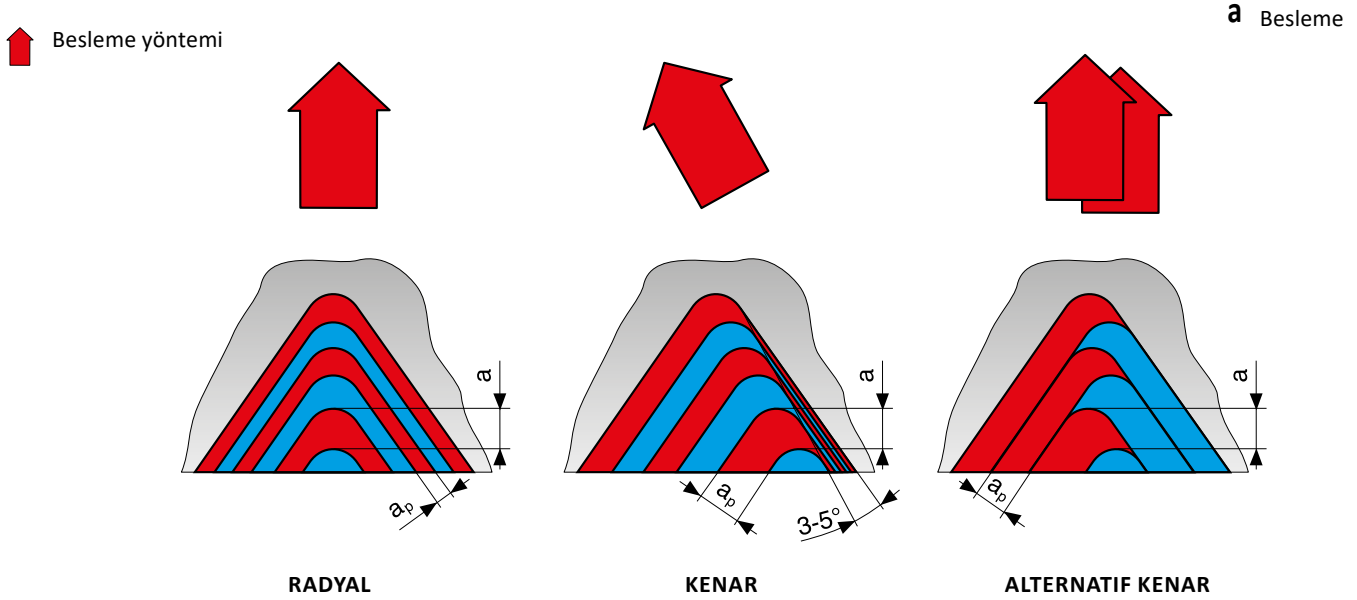

Seçim makine tipine, iş parçasına ve hatveye bağlıdır.

Radyal besleme – en basit ve en çok kullanılan yöntemdir. Besleme iş parçası dönme eksenine diktir. Kesme kenarı üzerinde düzenli aşınma ve iyi talaş oluşumuna katkı sağlar.

Küçük adımlı ($p < 1.5$ mm.) dişler için uygundur. Yüksek ilerlemelerde titreşime yol açar.

Sert malzemeler(örneğin: östenitik paslanmaz çelikler ve düşük karbonlu çelikler vb.) için ilk öneridir.

Kenar besleme – kesme kenarındaki ısıl gerilimi düşürerek aşınmayı azaltır. İyi talaş kontrolü sağlar. TR dişler için $p > 1.5$ mm hatveli dişler için uygundur. 3-5° sapmalı kenar besleme diş kenarı üzerindeki sürtünmeyi giderir.

Alternatif kenar besleme – kalın dişler ve zayıf talaş oluşturan malzemeler için tavsiye edilir. Uzun takım ömrüne sahiptirler. CNC makineler için daha yüksek CNC programlama gerektirir.

Besleme yöntemi ve paso sayısı diş hatvesine bağlıdır. Tablo tüm geometrilere uygulanabilen temel tavsiyeleri içerir. Uç kırılırsa, besleme değeri düşürülmeli ve paso sayısı artırılmalıdır. Besleme derinliği 0.05 mm/paso dan daha az olmamalıdır. Östenitik ve yumuşak çeliklerde her paso için besleme derinliği 0.08 mm'den daha büyük olmalıdır.

BORU SİLİNDİRİK DIŞ PROFİLİ W (WHITWORTH 55°)

Diş	Diş sayısı / 1"	Diş hatvesi [mm]	Nominal diş çapı [mm]	Küçük diş çapı [mm]	Diş ucu markalaması
G 1/16"	28	0,907	7.723	6.561	TN xxxx280W
G 1/8"			9.728	8.566	
G 1/4"	19	1,337	13.157	11.445	TN xxxx190W
G 3/8"			16.662	14.950	
G 1/2"	14	1,814	20.955	18.631	TN xxxx140W
G 5/8"			22.911	20.587	
G 3/4"			26.441	24.117	
G 7/8"			30.201	27.877	
G 1"	11	2,309	33.249	30.291	TN xxxx110W
G1 1/8"			37.897	34.939	
G1 1/4"			41.910	38.952	
G1 1/2"			47.803	44.845	
G1 3/4"			53.746	50.788	
G 2"			59.614	56.656	
G2 1/4"			65.710	62.752	
G2 1/2"			75.184	72.226	
G2 3/4"			81.534	78.576	
G3"			87.884	84.926	
G3 1/2"			100.330	97.372	
G4"			113.030	110.072	
G4 1/2"			125.730	122.772	
G5"			138.430	135.472	
G5 1/2"	151.130	148.172			
G6"	163.830	160.872			

Örnek: Boru 1 1/2" sağ diş çap diş için TN16ER110W;8030 Diş ucunu kullanınız.

BESLEME DERİNLİĞİ

M – Metrik 60° – Dış

Paso sayısı	DİŞ HATVESİNİN ARTTIRILMASI İÇİN KESME HIZININ ORANTILI OLARAK DÜŞÜRÜLMESİ														
	Hatve [mm]														
	6.0	5.5	5.0	4.5	4.0	3.5	3.0	2.5	2.0	1.75	1.5	1.25	1.0	0.75	0.50
1	0.46	0.43	0.41	0.37	0.34	0.34	0.28	0.27	0.24	0.22	0.22	0.21	0.18	0.16	0.11
2	0.43	0.40	0.39	0.34	0.32	0.31	0.26	0.24	0.22	0.20	0.20	0.17	0.16	0.14	0.09
3	0.35	0.32	0.32	0.28	0.25	0.25	0.21	0.20	0.18	0.17	0.17	0.14	0.12	0.11	0.07
4	0.30	0.28	0.27	0.24	0.22	0.21	0.18	0.17	0.16	0.14	0.14	0.11	0.11	0.07	0.06
5	0.29	0.26	0.24	0.22	0.20	0.18	0.16	0.15	0.14	0.12	0.12	0.10	0.08		
6	0.26	0.24	0.24	0.22	0.18	0.18	0.15	0.15	0.12	0.10	0.08	0.08			
7	0.24	0.21	0.22	0.20	0.17	0.16	0.14	0.12	0.11	0.10					
8	0.23	0.20	0.20	0.18	0.15	0.15	0.13	0.11	0.08	0.08					
9	0.22	0.19	0.19	0.17	0.14	0.14	0.12	0.11							
10	0.19	0.18	0.18	0.16	0.13	0.12	0.11	0.08							
11	0.18	0.17	0.16	0.14	0.12	0.11	0.10								
12	0.16	0.15	0.15	0.13	0.12	0.08	0.08								
13	0.15	0.14	0.12	0.12	0.11										
14	0.13	0.13	0.10	0.10	0.08										
15	0.13	0.12													
16	0.10	0.10													
Toplam besleme derinliği	3.83	3.52	3.19	2.87	2.53	2.23	1.92	1.60	1.25	1.13	0.93	0.81	0.65	0.48	0.33

M – Metrik 60° – İç

Paso sayısı	DİŞ HATVESİNİN ARTTIRILMASI İÇİN KESME HIZININ ORANTILI OLARAK DÜŞÜRÜLMESİ														
	Hatve [mm]														
	6.0	5.5	5.0	4.5	4.0	3.5	3.0	2.5	2.0	1.75	1.5	1.25	1.0	0.75	0.50
1	0.46	0.43	0.42	0.37	0.34	0.32	0.28	0.26	0.23	0.22	0.20	0.17	0.17	0.16	0.10
2	0.43	0.40	0.40	0.34	0.31	0.30	0.26	0.25	0.21	0.20	0.18	0.17	0.15	0.13	0.08
3	0.35	0.33	0.32	0.28	0.24	0.24	0.21	0.18	0.17	0.15	0.15	0.14	0.11	0.10	0.07
4	0.30	0.26	0.26	0.23	0.21	0.19	0.16	0.15	0.15	0.13	0.13	0.10	0.09	0.07	0.06
5	0.26	0.22	0.22	0.21	0.18	0.17	0.14	0.13	0.12	0.10	0.11	0.09	0.08		
6	0.22	0.20	0.20	0.19	0.15	0.15	0.13	0.12	0.11	0.09	0.08	0.08			
7	0.20	0.18	0.17	0.16	0.14	0.14	0.12	0.11	0.10	0.08					
8	0.19	0.17	0.16	0.15	0.13	0.13	0.11	0.10	0.08	0.08					
9	0.18	0.16	0.16	0.14	0.12	0.12	0.10	0.10							
10	0.16	0.15	0.15	0.13	0.12	0.11	0.10	0.08							
11	0.15	0.14	0.14	0.12	0.11	0.10	0.09								
12	0.15	0.14	0.14	0.12	0.10	0.08	0.08								
13	0.14	0.13	0.12	0.11	0.10										
14	0.13	0.12	0.10	0.10	0.08										
15	0.12	0.12													
16	0.10	0.10													
Toplam besleme derinliği	3.54	3.25	2.96	2.65	2.33	2.05	1.78	1.48	1.17	1.05	0.85	0.75	0.60	0.46	0.31

W – Whitworth 55° – Dış ve iç

Paso sayısı	DİŞ HATVESİNİN ARTTIRILMASI İÇİN KESME HIZININ ORANTILI OLARAK DÜŞÜRÜLMESİ																
	Pitch [no of thread/inch]																
	4	4.5	5	6	7	8	9	10	11	12	14	16	18	19	20	26	28
1	0.49	0.46	0.45	0.38	0.37	0.32	0.30	0.29	0.28	0.28	0.24	0.24	0.23	0.22	0.21	0.19	0.18
2	0.46	0.43	0.43	0.36	0.35	0.30	0.28	0.27	0.26	0.26	0.22	0.22	0.22	0.22	0.21	0.18	0.17
3	0.38	0.38	0.38	0.30	0.29	0.24	0.23	0.22	0.22	0.22	0.18	0.19	0.19	0.18	0.17	0.15	0.14
4	0.36	0.33	0.32	0.26	0.25	0.21	0.20	0.19	0.19	0.18	0.15	0.16	0.16	0.14	0.14	0.12	0.12
5	0.34	0.29	0.28	0.22	0.22	0.19	0.18	0.17	0.16	0.16	0.13	0.13	0.13	0.12	0.11	0.08	0.08
6	0.31	0.25	0.25	0.21	0.19	0.17	0.15	0.15	0.14	0.14	0.11	0.11	0.08	0.08	0.08		
7	0.29	0.24	0.22	0.19	0.18	0.15	0.14	0.14	0.13	0.13	0.09	0.08					
8	0.27	0.22	0.20	0.17	0.16	0.14	0.13	0.13	0.12	0.08	0.08						
9	0.24	0.20	0.19	0.16	0.15	0.13	0.12	0.12	0.08								
10	0.22	0.18	0.18	0.15	0.14	0.12	0.12	0.08									
11	0.20	0.17	0.17	0.14	0.12	0.12	0.08										
12	0.19	0.16	0.15	0.14	0.08	0.08											
13	0.17	0.15	0.12	0.12													
14	0.15	0.14	0.10	0.10													
15	0.12	0.12															
16	0.10	0.10															
Toplam besleme derinliği	4.29	3.82	3.44	2.90	2.50	2.17	1.93	1.76	1.58	1.45	1.20	1.13	1.01	0.96	0.92	0.72	0.69

UN – UN 60° – Dış

Paso sayısı	DİŞ HATVESİNİN ARTTIRILMASI İÇİN KESME HIZININ ORANTILI OLARAK DÜŞÜRÜLMESİ																	
	Pitch [no of thread/inch]																	
	4	4.5	5	6	7	8	9	10	11	12	13	14	16	18	20	24	28	32
1	0.47	0.45	0.43	0.36	0.35	0.30	0.28	0.27	0.27	0.27	0.25	0.23	0.22	0.23	0.20	0.19	0.17	0.17
2	0.44	0.41	0.40	0.34	0.33	0.28	0.26	0.26	0.25	0.26	0.24	0.22	0.21	0.21	0.19	0.17	0.15	0.15
3	0.40	0.39	0.36	0.27	0.26	0.25	0.21	0.20	0.20	0.20	0.18	0.17	0.16	0.16	0.15	0.14	0.11	0.13
4	0.36	0.31	0.31	0.23	0.22	0.21	0.20	0.17	0.19	0.18	0.17	0.15	0.14	0.14	0.12	0.12	0.09	0.08
5	0.32	0.26	0.26	0.22	0.21	0.18	0.17	0.16	0.16	0.15	0.14	0.13	0.13	0.12	0.10	0.08	0.08	
6	0.27	0.23	0.23	0.20	0.19	0.16	0.15	0.15	0.14	0.13	0.12	0.11	0.11	0.08	0.08			
7	0.25	0.21	0.20	0.18	0.17	0.14	0.14	0.14	0.12	0.12	0.11	0.10	0.08					
8	0.23	0.20	0.19	0.16	0.15	0.13	0.12	0.12	0.11	0.08	0.08	0.08						
9	0.22	0.18	0.19	0.15	0.14	0.12	0.12	0.11	0.08									
10	0.21	0.17	0.18	0.14	0.12	0.12	0.11	0.08										
11	0.19	0.16	0.17	0.13	0.11	0.11	0.08											
12	0.18	0.15	0.15	0.12	0.08	0.08												
13	0.16	0.14	0.12	0.11														
14	0.15	0.14	0.10	0.10														
15	0.12	0.12																
16	0.10	0.10																
Toplam besleme derinliği	4.07	3.62	3.29	2.71	2.33	2.08	1.84	1.66	1.52	1.39	1.29	1.19	1.05	0.94	0.84	0.70	0.60	0.53

UN – UN 60° – İç

Paso sayısı	DİŞ HATVESİNİN ARTTIRILMASI İÇİN KESME HIZININ ORANTILI OLARAK DÜŞÜRÜLMESİ																	
	Pitch [no of thread/inch]																	
	4	4.5	5	6	7	8	9	10	11	12	13	14	16	18	20	24	28	32
1	0.44	0.41	0.42	0.35	0.34	0.30	0.28	0.27	0.27	0.27	0.25	0.23	0.22	0.23	0.20	0.18	0.17	0.17
2	0.41	0.38	0.38	0.33	0.32	0.28	0.26	0.25	0.23	0.23	0.20	0.18	0.18	0.17	0.16	0.15	0.14	0.14
3	0.39	0.34	0.33	0.25	0.24	0.22	0.19	0.18	0.18	0.18	0.15	0.14	0.14	0.14	0.13	0.13	0.09	0.10
4	0.33	0.28	0.27	0.21	0.21	0.18	0.16	0.15	0.15	0.15	0.13	0.13	0.12	0.12	0.10	0.10	0.08	0.08
5	0.28	0.23	0.23	0.18	0.17	0.15	0.14	0.13	0.13	0.13	0.12	0.11	0.10	0.10	0.09	0.08	0.08	
6	0.24	0.20	0.20	0.16	0.15	0.13	0.13	0.12	0.11	0.11	0.11	0.10	0.09	0.08	0.08			
7	0.22	0.19	0.18	0.15	0.14	0.12	0.12	0.11	0.11	0.10	0.10	0.09	0.08					
8	0.21	0.18	0.17	0.14	0.13	0.11	0.11	0.10	0.10	0.08	0.08	0.08						
9	0.20	0.17	0.16	0.13	0.12	0.11	0.10	0.10	0.08									
10	0.18	0.16	0.15	0.12	0.12	0.10	0.09	0.08										
11	0.17	0.15	0.14	0.12	0.11	0.10	0.08											
12	0.16	0.14	0.14	0.11	0.08	0.08												
13	0.15	0.14	0.12	0.11														
14	0.14	0.13	0.10	0.10														
15	0.12	0.12																
16	0.10	0.10																
Toplam besleme derinliği	3.74	3.32	2.99	2.46	2.13	1.88	1.66	1.49	1.36	1.25	1.14	1.06	0.93	0.84	0.76	0.64	0.56	0.49

NPT 60° – İç ve Dış

Paso sayısı	DİŞ HATVESİNİN ARTTIRILMASI İÇİN KESME HIZININ ORANTILI OLARAK DÜŞÜRÜLMESİ				
	Pitch [no of thread/inch]				
	8	11.5	14	18	27
1	0.28	0.25	0.24	0.22	0.19
2	0.25	0.22	0.22	0.18	0.15
3	0.22	0.18	0.17	0.15	0.13
4	0.19	0.16	0.15	0.14	0.11
5	0.18	0.16	0.14	0.13	0.09
6	0.18	0.14	0.13	0.12	0.08
7	0.17	0.14	0.12	0.10	
8	0.17	0.12	0.10	0.08	
9	0.16	0.12	0.10		
10	0.16	0.10	0.08		
11	0.14	0.09			
12	0.13	0.08			
13	0.12				
14	0.11				
15	0.08				
Toplam besleme derinliği	2.54	1.76	1.45	1.12	0.75

RD – RD 30° – Dış

Paso sayısı	DİŞ HATVESİNİN ARTTIRILMASI İÇİN KESME HIZININ ORANTILI OLARAK DÜŞÜRÜLMESİ			
	Pitch [no of thread/inch]			
	4	6	8	10
1	0.44	0.33	0.29	0.26
2	0.40	0.29	0.26	0.25
3	0.34	0.25	0.21	0.23
4	0.32	0.23	0.19	0.20
5	0.28	0.20	0.18	0.16
6	0.26	0.18	0.16	0.12
7	0.24	0.16	0.14	0.10
8	0.22	0.15	0.12	0.08
9	0.20	0.14	0.10	
10	0.19	0.12	0.08	
11	0.17	0.10		
12	0.15	0.08		
13	0.12			
14	0.10			
Toplam besleme derinliği	3.43	2.23	1.73	1.40

RD – RD 30° – İç

Paso sayısı	DİŞ HATVESİNİN ARTTIRILMASI İÇİN KESME HIZININ ORANTILI OLARAK DÜŞÜRÜLMESİ			
	Pitch [no of thread/inch]			
	4	6	8	10
1	0.46	0.38	0.26	0.27
2	0.43	0.34	0.22	0.26
3	0.40	0.30	0.21	0.25
4	0.35	0.25	0.19	0.22
5	0.30	0.21	0.18	0.18
6	0.26	0.19	0.16	0.13
7	0.24	0.17	0.14	0.10
8	0.22	0.16	0.12	0.08
9	0.20	0.14	0.10	
10	0.19	0.12	0.08	
11	0.17	0.10		
12	0.15	0.08		
13	0.12			
14	0.10			
Toplam besleme derinliği	3.59	2.44	1.66	1.49

TR 30° – iç

Paso sayısı	DİŞ HATVESİNİN ARTTIRILMASI İÇİN KESME HIZININ ORANTILI OLARAK DÜŞÜRÜLMESİ											
	Hatve [mm]											
	14,0	12,0	10,0	9,0	8,0	7,0	6,0	5,0	4,0	3,0	2,0	1,5
1	0.40	0.38	0.38	0.38	0.37	0.37	0.37	0.34	0.31	0.27	0.25	0.23
2	0.37	0.36	0.36	0.35	0.35	0.34	0.35	0.33	0.28	0.25	0.24	0.22
3	0.36	0.34	0.34	0.34	0.34	0.33	0.32	0.27	0.24	0.21	0.20	0.18
4	0.36	0.34	0.34	0.33	0.33	0.31	0.29	0.25	0.20	0.17	0.17	0.14
5	0.35	0.32	0.32	0.31	0.31	0.29	0.27	0.23	0.19	0.15	0.14	0.12
6	0.35	0.32	0.32	0.30	0.29	0.26	0.25	0.21	0.18	0.13	0.13	0.08
7	0.34	0.30	0.31	0.29	0.28	0.26	0.23	0.20	0.16	0.13	0.11	
8	0.34	0.30	0.29	0.28	0.27	0.26	0.22	0.20	0.15	0.12	0.09	
9	0.34	0.30	0.28	0.26	0.25	0.24	0.22	0.18	0.15	0.12		
10	0.33	0.29	0.27	0.25	0.24	0.23	0.20	0.16	0.15	0.10		
11	0.33	0.29	0.25	0.24	0.23	0.22	0.18	0.15	0.14	0.10		
12	0.32	0.29	0.24	0.23	0.21	0.22	0.17	0.14	0.13	0.08		
13	0.32	0.28	0.23	0.22	0.20	0.20	0.17	0.13	0.10			
14	0.31	0.27	0.22	0.21	0.19	0.19	0.16	0.10				
15	0.31	0.25	0.22	0.21	0.19	0.17	0.14					
16	0.30	0.25	0.20	0.19	0.18	0.16	0.12					
17	0.30	0.24	0.19	0.18	0.17	0.12						
18	0.29	0.22	0.18	0.16	0.15							
19	0.28	0.20	0.17	0.15	0.13							
20	0.27	0.20	0.16	0.15								
21	0.23	0.19	0.15	0.13								
22	0.23	0.18	0.15									
23	0.21	0.17	0.13									
24	0.19	0.16										
25	0.17	0.15										
26	0.16	0.13										
27	0.16											
28	0.15											
29	0.13											
Toplam besleme derinliği	8.2	6.72	5.7	5.16	4.68	4.17	3.66	2.89	2.38	1.83	1.33	0.97

TR 30° – İç

Paso sayısı	DİŞ HATVESİNİN ARTTIRILMASI İÇİN KESME HIZININ ORANTILI OLARAK DÜŞÜRÜLMESİ											
	Hatve [mm]											
	14,0	12,0	10,0	9,0	8,0	7,0	6,0	5,0	4,0	3,0	2,0	1,5
1	0.40	0.38	0.38	0.38	0.37	0.37	0.37	0.34	0.31	0.27	0.25	0.23
2	0.37	0.36	0.36	0.35	0.35	0.34	0.34	0.33	0.28	0.25	0.24	0.22
3	0.36	0.34	0.34	0.34	0.34	0.33	0.32	0.27	0.24	0.22	0.21	0.19
4	0.36	0.34	0.34	0.33	0.33	0.31	0.29	0.25	0.20	0.17	0.17	0.14
5	0.35	0.32	0.32	0.31	0.31	0.29	0.27	0.23	0.19	0.15	0.14	0.12
6	0.35	0.32	0.32	0.31	0.29	0.26	0.25	0.21	0.18	0.14	0.13	0.08
7	0.34	0.30	0.31	0.29	0.28	0.26	0.23	0.20	0.16	0.13	0.11	
8	0.34	0.30	0.29	0.29	0.27	0.26	0.22	0.20	0.15	0.12	0.09	
9	0.34	0.30	0.28	0.26	0.25	0.24	0.22	0.18	0.15	0.12		
10	0.33	0.29	0.27	0.25	0.24	0.23	0.20	0.16	0.15	0.10		
11	0.33	0.29	0.25	0.24	0.23	0.22	0.18	0.15	0.14	0.10		
12	0.32	0.28	0.24	0.23	0.21	0.22	0.17	0.14	0.13	0.08		
13	0.32	0.28	0.23	0.22	0.20	0.20	0.17	0.13	0.10			
14	0.31	0.27	0.22	0.21	0.19	0.19	0.16	0.10				
15	0.31	0.25	0.22	0.21	0.19	0.17	0.14					
16	0.30	0.25	0.20	0.20	0.18	0.16	0.12					
17	0.30	0.24	0.19	0.18	0.17	0.12						
18	0.29	0.22	0.18	0.16	0.15							
19	0.28	0.20	0.17	0.15	0.13							
20	0.27	0.20	0.16	0.15								
21	0.27	0.19	0.15	0.13								
22	0.23	0.18	0.15									
23	0.23	0.17	0.13									
24	0.21	0.16										
25	0.19	0.15										
26	0.17	0.13										
27	0.16											
28	0.16											
29	0.15											
30	0.13											
Toplam besleme derinliği	8.47	6.71	5.7	5.19	4.68	4.17	3.65	2.89	2.38	1.85	1.34	0.98

BSPT 55° – İç ve Dış

Paso sayısı	DİŞ HATVESİNİN ARTTIRILMASI İÇİN KESME HIZININ ORANTILI OLARAK DÜŞÜRÜLMESİ			
	Pitch [no of thread/inch]			
	11	14	19	28
1	0.22	0.19	0.19	0.15
2	0.21	0.18	0.18	0.14
3	0.20	0.17	0.17	0.13
4	0.19	0.16	0.15	0.12
5	0.18	0.15	0.13	0.08
6	0.16	0.14	0.08	
7	0.15	0.12		
8	0.13	0.08		
9	0.08			
Toplam besleme derinliği	1.52	1.19	0.90	0.62

ACME – ACME 29° – Dış

Paso sayısı	DİŞ HATVESİNİN ARTTIRILMASI İÇİN KESME HIZININ ORANTILI OLARAK DÜŞÜRÜLMESİ							
	Pitch [no of thread/inch]							
	4	5	6	8	10	12	14	16
1	0.37	0.34	0.32	0.29	0.27	0.25	0.22	0.23
2	0.34	0.32	0.28	0.25	0.23	0.22	0.20	0.21
3	0.30	0.25	0.23	0.21	0.20	0.17	0.18	0.18
4	0.27	0.23	0.21	0.17	0.18	0.14	0.15	0.14
5	0.25	0.22	0.18	0.15	0.14	0.13	0.13	0.12
6	0.24	0.20	0.18	0.13	0.12	0.12	0.11	0.08
7	0.21	0.19	0.16	0.13	0.12	0.10	0.08	
8	0.20	0.19	0.16	0.12	0.11	0.09		
9	0.20	0.18	0.16	0.12	0.11			
10	0.18	0.16	0.15	0.11	0.09			
11	0.17	0.15	0.14	0.11				
12	0.16	0.14	0.13	0.09				
13	0.16	0.13	0.11					
14	0.15	0.11						
15	0.14							
16	0.12							
Toplam besleme derinliği	3.46	2.83	2.41	1.88	1.57	1.22	1.07	0.96

ACME – ACME 29° – İç

Paso sayısı	DİŞ HATVESİNİN ARTTIRILMASI İÇİN KESME HIZININ ORANTILI OLARAK DÜŞÜRÜLMESİ							
	Pitch [no of thread/inch]							
	4	5	6	8	10	12	14	16
1	0.37	0.34	0.32	0.29	0.27	0.25	0.22	0.23
2	0.33	0.31	0.27	0.25	0.23	0.22	0.20	0.21
3	0.30	0.25	0.23	0.21	0.20	0.17	0.18	0.17
4	0.27	0.23	0.20	0.17	0.18	0.15	0.15	0.14
5	0.25	0.22	0.18	0.15	0.15	0.13	0.13	0.12
6	0.23	0.20	0.18	0.14	0.12	0.12	0.11	0.08
7	0.21	0.19	0.16	0.13	0.12	0.10	0.08	
8	0.20	0.19	0.15	0.12	0.11	0.09		
9	0.20	0.17	0.15	0.12	0.11			
10	0.18	0.16	0.15	0.12	0.09			
11	0.17	0.15	0.14	0.11				
12	0.16	0.14	0.13	0.09				
13	0.16	0.13	0.11					
14	0.15	0.11						
15	0.14							
16	0.12							
Toplam besleme derinliği	3.44	2.78	2.38	1.90	1.59	1.23	1.07	0.95

Oyuklar, dilimleme ve kopya tornalama.

Pramet, siğ ve derin oyukları hem radyal hem de aksel olarak tornalamak için kapsamlı bir takım yelpazesi sunar (alına kanal açma). Yan kesim yoluyla dairesel/kopya profil tornalama da yapılabilir.

Pratik kullanım için öneri:

Bir oyuğu tornalama (derinleştirme ve genişletme) prosedürü aşağıdaki şekilde gösterilmiştir.

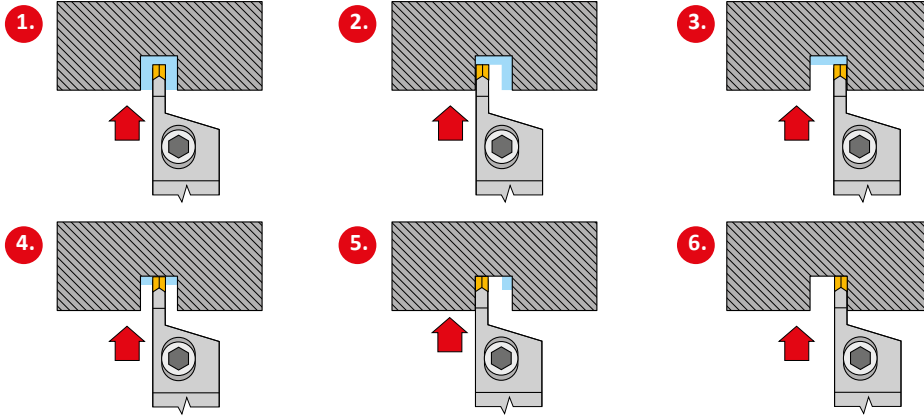

Not: Düz bir yuva yüzeyi oluşturmak için, **GL** tipi ucu **GM** talaş kırıcısıyla veya **LCMF** ucu **F** talaş kırıcısıyla birlikte kullanın. Dışa doğru radyal kanal açma geçişleri, uç köşe yarıçapının iki katı kadar olarak merkezi geçişle örtüşmelidir.

Geniş bir oyuğu işlerken, aşağıdaki şekilde gösterilen prosedürü izleyin.

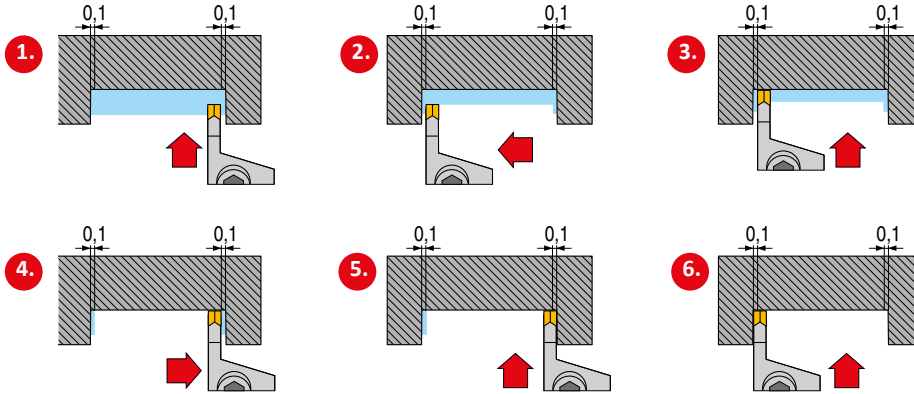

Not: LCMF kesici ucunu talaş kırıcı M ile kullanın. Takımın "y" deformasyonu da dikkate alınmalıdır:

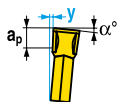

- $f=0,15$ mm/dev için;
- $f=0,25$ mm/dev için;
 $f=0,35$ mm/dev için;

$a_p = 3$ mm
 $a_p = 3$ mm
 $a_p = 3$ mm

$y = 0,07$ mm
 $y = 0,08$ mm
 $y = 0,10$ mm

Yan tornalama kullanarak bir konturu açarken veya derinleştirirken, aşağıdaki resimde gösterilen prosedürü kullanın.

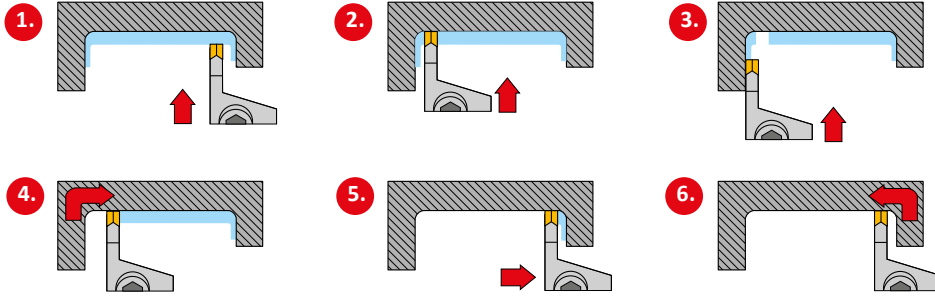

Konturun kaba işlenmesi (yuvarlak kesme kenarlı kesici uç)

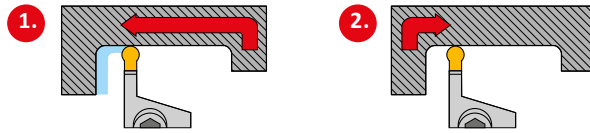

Konturun finiş işlemesi (yuvarlak kesme kenarlı kesici uç)

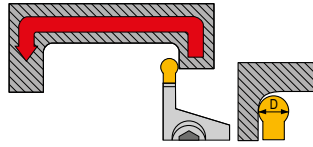

D (mm)	a_p (mm)
3	0.15
4	0.20
5	0.22
6	0.25
8	0.40

Yuvarlak kesme kenarlı değiştirilebilir kesici uçlar kullanarak kopya tornalama yaparken maksimum kesme derinliği kesici uç çapının %50'sidir.

Titreşimleri ortadan kaldırmak için takım tutucusunu maksimum kesit ve minimum takım kullanma mesafesine sahip olarak seçin.

Kesici ucun uzunlamasına eksenine iş parçasının dönme eksenine dik olmalıdır (radyal oyuklarda).

Kesme kenarı, merkez çizgisinde ve ± 0.1 mm tolerans dahilinde olmalıdır

Kesme sıvısı, kesici ucun etkili bir şekilde soğutulmasını sağlamak üzere yeterli miktarlarda doğrudan kesici kenara ve kesici uç kesme kenarının altındaki takım tutucunun destek alanına uygulanmalıdır.

Alına kanal açma sırasında, işlenecek kanal için doğru çap aralığına sahip bir takım tutucu seçmek gereklidir. Takım, iş parçasının dönme eksenine paralel (kanalın yüzüne dik) ayarlanmalıdır. Aksi halde, işleme sırasında oluşun duvarlarına sürtünme riski vardır.

Takım kanalın dış duvarına sürtünüyorsa, kesici kenarı merkezin yukarısına kaldırmak gerekli olabilir (bkz. Resim 'daki örnek A).



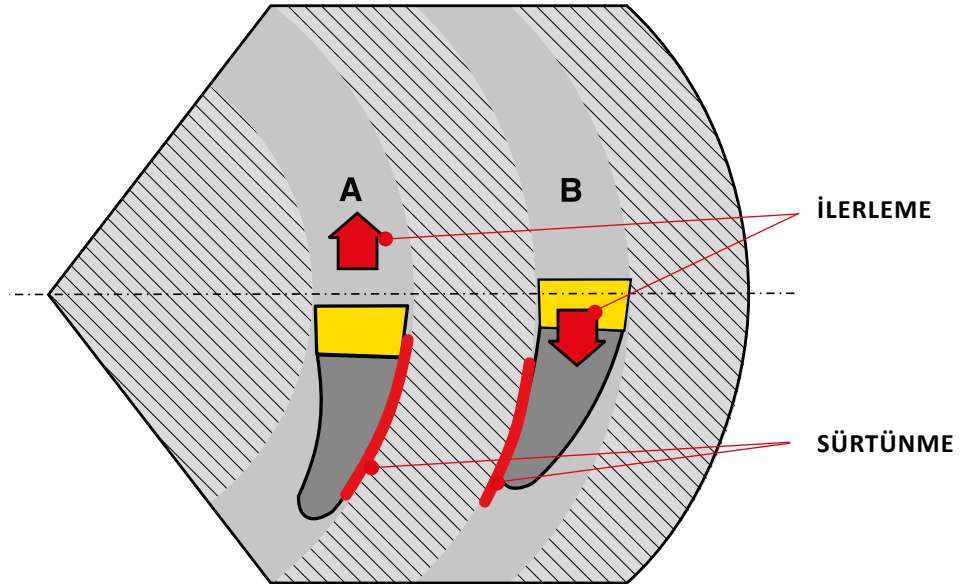





Alına kanal açarken, takım iş parçasının yüzüne hassas bir şekilde dik olarak ayarlanmalıdır, aksi halde takımın yan tarafı oluşturulan oluğa sürtünecektir.

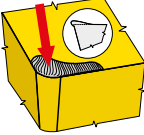
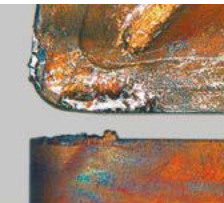







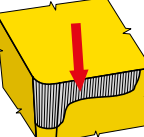

Yeterli miktarlarda ve doğrudan kesme kenarına uygulanan etkili kesme sıvısı kullanılması çok önemlidir. Soğutma, kesme kenarının ve kesici ucun oturduğu takım tutucunun alt kısmının sıcaklığını azaltır.

TORNA UÇLARI AŞINMA TİPLERİ







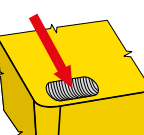
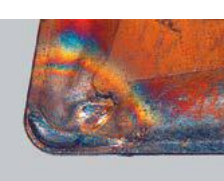

TALAŞ YIĞILMASI

 		Etkisi yok
		++ Herhangi bir kaplama (belirleyici faktör yapışmayı önleyici etkidir)
		↑ İlerleme hızı ne kadar yüksek olursa, yığılma oluşma ihtimali daha az olur
		↓ ↑ Kesme hızını değiştirin (genellikle arttırın)
		Etkisi yok
		↓ ↑ Daha pozitif geometri kullanın (Açı 40 °,den fazla olduğunda yığılma oluşturmaz)
		- Daha etkin yapışma önleyici özelliğe sahip soğutma kullanın

SERBEST YÜZEY AŞINMASI







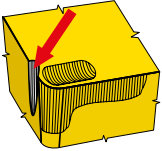
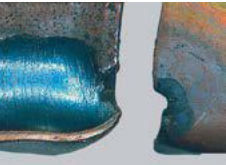

 		↑ Aşınmaya karşı daha dirençli alt yapı (S) kullanın
		++ Herhangi bir kaplama (belirleyici faktör oksidasyon direncidir - α Al_2O_3)
		↑ İlerlemenin, kanalın şekli ve konumu üzerinde etkisi vardır
		↓ Kesme hızını düşürün
		↑ Minimum etki
		+ Başka (daha pozitif) kesme geometrisi kullanın
		+ Soğutma kullanın veya yoğunluğunu arttırın

KRATER AŞINMASI







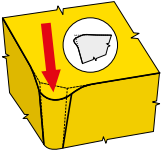
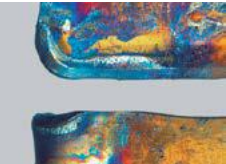

 		↑ Aşınmaya karşı daha dirençli alt yapı (S) kullanın
		++ Herhangi bir kaplama (belirleyici faktör oksidasyon direncidir - α Al_2O_3)
		↑ İlerlemenin, kraterin şekli ve konumu üzerinde etkisi vardır
		↓ Kesme hızını düşürün
		↓ Minimum etki
		↑ Daha fazla pozitif kesme geometrisi kullanın
		++ Soğutma kullanın veya yoğunluğunu arttırın

TORNA UÇLARI AŞINMA TİPLERİ







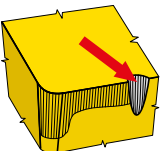
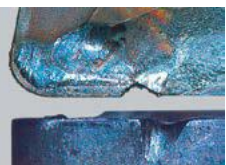

YARDIMCI KENARDA ÇENTİK OLUŞUMU

 		↑	Aşınmaya karşı daha dirençli kalite (H) kullanın
		++	Herhangi bir kaplama (belirleyici faktör sertlikler - TiC, TiCN)
		↓	İlerleme (özellikle 0.1 mm'nin altında ise) arttırılmalıdır.
		↓	Kesme hızını düşürün
		↓	Etkisi yok
		↑	Serbest yüzey açısının arttırılması en önemlisidir
		++	Soğutma kullanın veya yoğunluğunu arttırın

PLASTİK DEFORMASYON







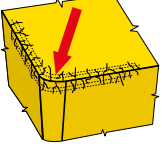

 		↑	Aşınmaya karşı daha dirençli kalite kullanın (belirleyici faktör Co)
		+	Herhangi bir kaplama (belirleyici faktör sürtünme)
		↓	İlerlemeyi düşürün
		↓	Kesme hızını düşürün
		↓	Minimum etki
		↑	Başka (daha pozitif) kesme geometrisi kullanın
		++	Soğutma kullanın veya yoğunluğunu arttırın

ÇENTİK AŞINMASI







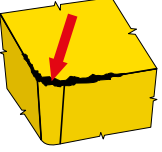

 		↑ ↓	Hasarın niteliğine bağlıdır (aşınma-aşınmaya karşı daha dirençli kalite kullanın , kırılma - daha sünek altyapı kullanın)
		++	CVD kaplama (belirleyici faktör oksidasyon direncidir - α Al ₂ O ₃)
		↓	Avansul are influenta asupra intensitatii, dar mai mica decat viteza de aschierellerleme yoğunluğu etkiler, ancak kesme hızından daha küçüktür
		↓	Kesme hızını düşürün
		↑ ↓	Değişken kesme derinliği kullanın
		↓	Daha az pozitif kesme geometrisi kullanın
		+	Soğutma kullanın veya yoğunluğunu arttırın
			Daha küçük yanaşma açılı takım kullanın

TORNA UÇLARI AŞINMA TİPLERİ







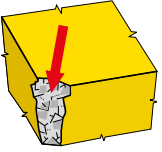

ÇATLAK OLUŞUMU

 		↓ (H) tane yapısının büyük etkisi var
		++ PVD kaplama tavsiye edilir
		↓ İlerleme yoğunluğu etkiler, ancak kesme hızından daha küçüktür
		↓ Daha düşük hız daha düşük sıcaklık oluşturur
		Etkisi yok
		↓ Daha az pozitif kesme geometrisi kullanın
		- - - Soğutma yok (mümkünse talaşı uzaklaştırmak için hava kullanılmalıdır)

KESME KENARININ UFAK PARÇALAR HALİNDE KOPMASI

 		↓ (H) tane yapısının büyük etkisi var
		+ PVD kaplama tavsiye edilir
		↓ İyi talaş kırılması çok önemlidir
		↑ ↓ Talaş kırılması ve titreşimler ile ilgilidir
		↓ Kuvvet yükünü düşürün (uzun takım boyları ile işleme için önemli)
		↓ Daha az pozitif kesme geometrisi kullanın
		Etkisi yok
		Daha uygun çalışma şartları belirleyin, girişte ilerlemeyi düşürün

KESİCİ KENARIN KIRILMASI

 		↓ (H) tane yapısının büyük etkisi var
		+ PVD kaplama tavsiye edilir
		↓ İyi talaş kırılması çok önemlidir
		↑ ↓ Talaş kırılması ve titreşimler ile ilgilidir
		↓ İyi talaş kırılması çok önemlidir
		↓ Daha az pozitif kesme geometrisi kullanın
		Etkisi yok
		Problem kötü talaş kırılması, talaş tahliyesi veya uzaklaştırılmasıdır

KESİCİ UCUN KIRILMASI

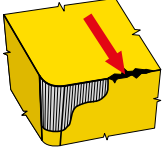

	↓	(H) tane yapısının büyük etkisi var
(MT)CVD PVD	+	PVD kaplama tavsiye edilir
f	↑ ↓	Kuvvet yükünü düşürün
v	↑ ↓	Talaş kırılması ve titreşimler ile ilgilidir
a _p	↑ ↓	Kuvvet yükünü düşürün
	↓	Daha az pozitif kesme geometrisi kullanın
		Etkisi yok
		Daha uygun çalışma şartları belirleyin

KÖTÜ YÜZEY KALİTESİ

Tanımı ve nedeni:

İş parçası malzemesi, kesme şartları, kesme kenarı durumu, aşınma tipi ve durumu, tezgah-takım-işparçası rijitliği gibi bir çok farklı nedene bağlıdır.

- Yanlış takım seçimi
- Yanlış talaş kalınlığı
- Yanlış kesme hızı
- Soğutma ihtiyacı
- Yüksek ilerleme

Düzeltilici önlemler:

- Silicili uç kullanın
- Doğru geometri uç kullanın
- İlerlemeyi düşürün
- Kesme hızını değiştirin (genellikle arttırın)
- Soğutma kullanın
- Takım ve iş parçası stabilitesini arttırın
- Talaş kesitini değiştirin
- Daha kolay talaş kırıcı seçin
- Uç radiusunu arttırın

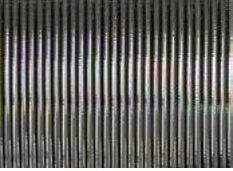

TİTREŞİMLER

Tanımı ve nedeni:

Genellikle dengesiz iş parçası veya takım, iş parçasının doğru sıkılmamasından, yüksek kesme hızlarından veya takım boyundan kaynaklanan çok rastlanan bir problemdir.

Düzeltilici önlemler:

- Takım ve iş parçası stabilitesini arttırın
- Kesme derinliğini düşürün
- Takım boyunu minimize edin
- Kesme hızını düşürün
- Daha küçük yavaşma açılı takım kullanın
- Talaş kesitini düşürün
- Düşük kesme dirençli takım kullanın
- İlerlemeyi arttırın
- Daha kolay talaş kırıcı seçin
- Uç radiusunu arttırın



ÇAPAKLAR

Tanımı ve nedeni:

Genellikle yumuşak çeliklerde ve plastik malzemelerde meydana gelir.

Düzeltilici önlemler:

- Keskin kenarlı kesici uç kullanın
- Pozitif geometri kesici uç kullanın
- Daha küçük yavaşma açılı takım kullanın

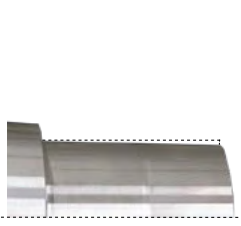

İŞ PARÇASI ÖLÇÜ VE BOYUT HATALARI

**Tanımı ve nedeni:**

Çok sayıda etkene bağlıdır.

Düzeltilici önlemler:

- Aşınmaya karşı dirençli uç kullanın
- İş parçası ve takım stabilitesini arttırın
- Takım boyunu minimize edin
- Uygun işleme toleranslarında iş parçası kullanın

YETERSİZ TALAŞ OLUŞUMU

**Tanımı ve nedeni:**

Düzgün şekilli talaş oluşumu en az takım ömrü dayanıklılığı kadar önemlidir. İş parçası malzemesi, ilerleme, kesme derinliği ve kesme geometrisi hepsi talaş oluşumu üzerinde etkilidir. Talaşın uzun olması bir çok nedenden dolayı kabul edilemez. Fakat kesme kenarı üzerinde yük oluşturması ve titreşime neden olmasından dolayı da çok kısa talaş olması istenmez.

Düzeltilici önlemler:

- İlerleme ve kesme derinliğini değiştirin
- Daha uygun kesme geometrisi kullanın
- Kesme şartlarını değiştirin

KESİCİ UÇ YUVASININ DURUMUNU KONTROLÜ

Yeni uç sıkmadan veya köşe değiştirmeden önce uç yuvasının durumunu, altlık ve pabucu (özellikle ucun kesici köşesinin altındaki hasarı) kontrol ederek mutlaka temizleyiniz.

SIKMA PARÇALARININ KONTROLÜ VE SERVİSİ

Levy, vida, altlık ve pabuç gibi sıkma parçalarının kontrolü çok önemlidir. Sadece katalogta belirtilen hasarsız orjinal yedekleri kullanınız. Dişleri ve vida temas yüzeylerini örneğin (Molykotet G.) gibi ısıya karşı dirençli yağ ile düzenli olarak yağlayınız. Takma ve sökme için sadece katalogta belirtilen veya takım üreticisi tarafından tavsiye edilen anahtar ve tornavidaları kullanınız. Doğru ve orantılı sıkmaya dikkat edin. Tork anahtarını kullanmanız tavsiye edilir.

SIKMA KONTROLÜ

Sıkmadan önce radyal ve eksenel yönlerde ve tüm sıkma yüzeyine kesici ucun uygunluğunu kontrol edin. Kesici uç ve takımlar temiz ve hasarsız olmalıdır.



İşlenmiş malzeme – iş parçası malzemesinin işlenebilirliğinin kötüleşmesine paralel olarak kesme ortamının etkisi artar.

Kesme kalitesi – tokluğun (Co içeriği) artışına paralel olarak kesme ortamının etkisi artar. Soğutma sadece yüksek hızlı işleme için tavsiye edilmez, ör. CBN ve seramik uygulamaları için.

İlerleme – ilerlemenin artışına paralel olarak kesme sıvısının takım ömrüne katkısı da artar.

Kesme hızı (işlenen malzeme için tipik olarak) – kesme hızı ne kadar yüksekse, kesme sıvısının soğutma etkisi o kadar önemlidir ve tersine kesme hızı ne kadar düşükse kesme sıvısının yağlama etkisi o kadar önemlidir.

Sıvı beslemesi de kesim işleminin ekonomisini ve verimliliğini güçlü

bir şekilde etkileyen kriterlerden biridir. İdeal olarak sıvı, takımın hem alın hem de yanak tarafına verilebilir. Kesme sıvısının yanak tarafından verilmesi sadece takım ömrünü etkiler. Öte yandan, takımın alın tarafından kesme sıvısı verilmesi bazı durumlarda talaş oluşturmaya yardımcı olabilir (özellikle yüksek basınçlı soğutma durumunda). Alternatiflerden sadece biri mümkünse, doğru yönü aşınmanın tipi gösterecektir. Uçlar yanak tarafından aşınmışsa sıvıyı aşağıdan vermeye, yani ucun yan tarafına getirmeye çalışın. Bir krater oluşumu halinde sıvı, aletin alın bölümüne (köküne değil talaşın altına) verilmelidir.

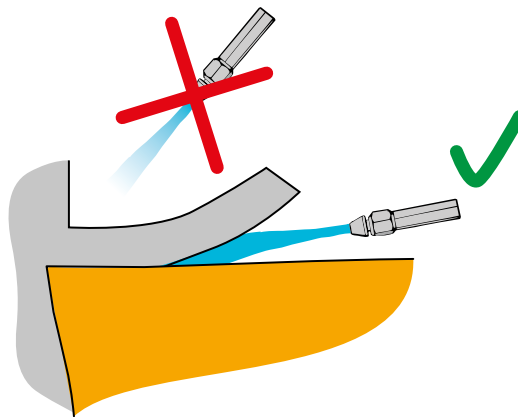

KESME HIZI FORMÜLLERİ

Değer	Formül	Birim	Not
Fener mili hızı	$n = \frac{v_c \cdot 1000}{D \cdot \pi}$	[1/dk]	<p>n Fener mili hızı [1/dk]</p> <p>D Çap (takım veya işparçası) [mm]</p>
Kesme hızı	$v_c = \frac{\pi \cdot D \cdot n}{1000}$	[m/dk]	<p>v_c Kesme hızı [m/dk]</p> <p>f_{rev} Devir başına ilerleme [mm/dev]</p> <p>f_{min} Dakika başına ilerleme [mm/dk]</p>
Devir başına ilerleme	$f_{rev} = \frac{f_{min}}{n}$	[mm/dev]	
Dakika başına ilerleme	$f_{min} = v_c \cdot n$	[mm/dk]	
Maks.Yüzey yüksekliği R_{max}	$R_{max} = \frac{125 \cdot f_{rev}^2}{RE}$	[mm]	<p>R_{max} Maks.Yüzey yüksekliği [mm]</p> <p>R_a Yüzey kalitesi [mm]</p>
Yüzey kalitesi R_a	$R_a = \frac{43,9 \cdot f_{rev}^{1,88}}{RE^{0,97}}$	[mm]	<p>f_{rev} Devir başına ilerleme [mm/dev]</p> <p>RE Uç radyusu [mm]</p>
Talaş kesiti	$A = f_{rev} \cdot a_p$	(mm ²)	<p>A Talaş kesiti [mm²]</p> <p>f_{rev} Devir başına ilerleme [mm/dev]</p>
Talaş kalınlığı (düz kenarlı uçlar için)	$h = f_{rev} \cdot \sin \kappa_r$	(mm)	<p>a_p Eksenel paso [mm]</p> <p>κ_r Birinci köşe yanaşma açısı [°]</p> <p>h Talaş kalınlığı [mm]</p>
Talaş kalınlığı (yuvarlak kesici uçlar için)	$h = f_{rev} \cdot \sqrt{\frac{a_p}{INSD}}$	(mm)	<p>v_c Kesme hızı [m/dk]</p> <p>f_{min} Dakika başına ilerleme [mm/dk]</p> <p>Q Dakikada talaş kaldırma hacmi [cm³/dk]</p> <p>$INSD$ Kesici uç çapı (mm)</p>
Talaş kaldırma hacmi	$Q = a_p \cdot f_{rev} \cdot v_c$	(cm ³ /dk)	
Güç gereksinimi	$P_c = \frac{a_p \cdot f_{rev}^{1-c} \cdot k_{cl} \cdot v_c \cdot k \kappa_r}{6 \cdot 10^4 \cdot \eta}$	(kW)	<p>P_c Güç gereksinimi [kW]</p> <p>a_p Paso [mm]</p> <p>f_{rev} rev İlerlem (mm/dev) [mm/dev]</p>
Ortalama güç gereksinimi	$P_c = \frac{a_p \cdot f_{rev} \cdot v_c}{x}$	(kW)	<p>c Sabit KTV [1]</p> <p>k_c Özgül kesme kuvveti [MPa]</p> <p>k_{κ_r} κ_r sabit açısı [1]</p> <p>η Verimlilik (genellikle $\eta = 0,75$) [1]</p> <p>x Malzeme sabiti [1]</p>

Malzeme	Çelik	Dökme Demir	Al
Katsayısı x	20	25	100

TAVSİYE EDİLEN TORK ANAHTARLARI

VİDA SIKMA

Vida tipi	Vida	Tork (Nm)*
28588	MA2-8304	0.8
28992	MA2-8304	0.8
416.1-832	PT-8002	3.6
5513 020-01	PT-8004	3.6
5513 020-03	PT-8001	0.8
5513 020-04	PT-8003	1.5
5513 020-05	PT-8001	0.8
5513 020-14	TX 225PLUS	8.5
5513 020-24	PT-8002	1.5
5513 020-27	PT-8000	0.6
5513 020-28	PT-8000	0.6
5513 021-03	DMN 3124	13
CS 8601-T09P	SDR T09P	1.7
CS 8601-T15P	SDR T15P	3.9
CS 8601-T20P	SDR T20P	6.4
CS 8601-T25P	SDR T25P	9.5
DVF 0573	PT-8002	1.5
DVF 2260	TX 215PLUS	3.6
DVF 3584	DMD 1650	0.6
DVF 3593	TX 207PLUS	0.8
HS 0408	HXX 3	5
HS 0520C	HXX 4	5
HS 0616C	HXX 5	8
HS 0620	HXX 5	6
HS 0620C	HXX 5	6
HS 0625	HXX 5	6
HS 0625C	HXX 5	6
HS 0630	HXX 5	6
HS 0825	HXX 6	10
HS 0830	HXX 6	10
HS 0835	HXX 6	10
HS 0840	HXX 8	11
HS 1030	HXX 8	8
HS 1060	HXX 6	10
HS 93	HXX 5	8
HS 94	HXX 5	8
HSI 1020	HXX 6	8
PS 0512	HXX 2	2
PS 0512-A	HXX 2	2
PS 0616	HXX 2,5	4
PS 12040	HXX 5	8
PS 6026-709P	SRD T09P	2

VİDA SIKMA

Vida tipi	Vida	Tork (Nm)*
PS 8290	HXX 2	2
SR 14	HXX 10	10
SR 85011-T15P	SDR T15P	5
SR 85017-T09P	SDR T09P	2
SR 85020-T15P	SDR T15P	3
SR 86025-T20P	SRD T20P	5
T20.037	DMD 1650	0.6
UP 0909-T09P	SRD T09P	2
UP 1515-T15P	SDR T15P	8
US 2505-T07P	SDR T07P	0.9
US 2506-T07P	SDR T07P	0.9
US 3007-T09P	SDR T09P	2
US 34	HXX 3	5
US 35	HXX 4	6
US 3508-T15P	SDR T15P	3
US 3510A-T15P	SDR T15P	3
US 3510-T15P	SDR T15P	3
US 3512A-T15P	SDR T15P	3
US 3512-T15P	SDR T15P	3
US 36	HXX 4	6
US 38	HXX 5	8
US 39	HXX 5	8
US 40	HXX 4	6
US 4008-T15P	SDR T15P	3.5
US 4011-T15P	SDR T15P	3.5
US 41	HXX 4	6
US 42	HXX 4	6
US 45013-T20P	SDR T20P	5
US 4512-T15P	SDR T15P	5
US 4514A-T20	SDR T20	5
US 46	HXX 3	5
US 46017-T20P	SDR T20P	5
US 47	HXX 5	8
US 5012-T15P	SDR T15P	5
US 5015-T20P	SDR T20P	5
US 5018-T20P	SDR T20P	5
US 6020-T25P	SDR T25P	6
US 64518-T15P	SDR T15P	5
US 8025-T30P	SDR T20P	13
US 83	HXX 4	6
US 95	HXX 4	10

TORK ANAHTARLARI

Tork kolu	Tork (Nm)	Vida dışı sıkma
MR-0.8-2.0 vario	0.5 – 2.0	M 2 – M 3
MR-1.0-5.0 vario	0.8 – 5.0	M 2.5 – M 5
MR-0.9 fix	0.9	M 2
MR-2.0 fix	2.0	M 3
MR-3.0 fix	3.0	M 3.5
MR-3.5 fix	3.5	M 4
MR-5.0 fix	5.0	M 5

DEĞİŞTİRİLEBİLİR GÖVDELER

Değiştirilebilir gövdeler		
D-T6	D-T8	D-T15
D-T6P	D-T8P	D-T15P
D-T7	D-T9	D-T20
D-T7P	D-T9P	D-T20P

VİDA YAĞLAMA

Uç sıkma vidaları yüksek ısı gerilime maruz kalır. Tüm vidaların MOLYCOTE 1000 gibi yüksek kaliteli macun ile yağlanması tavsiye edilir.

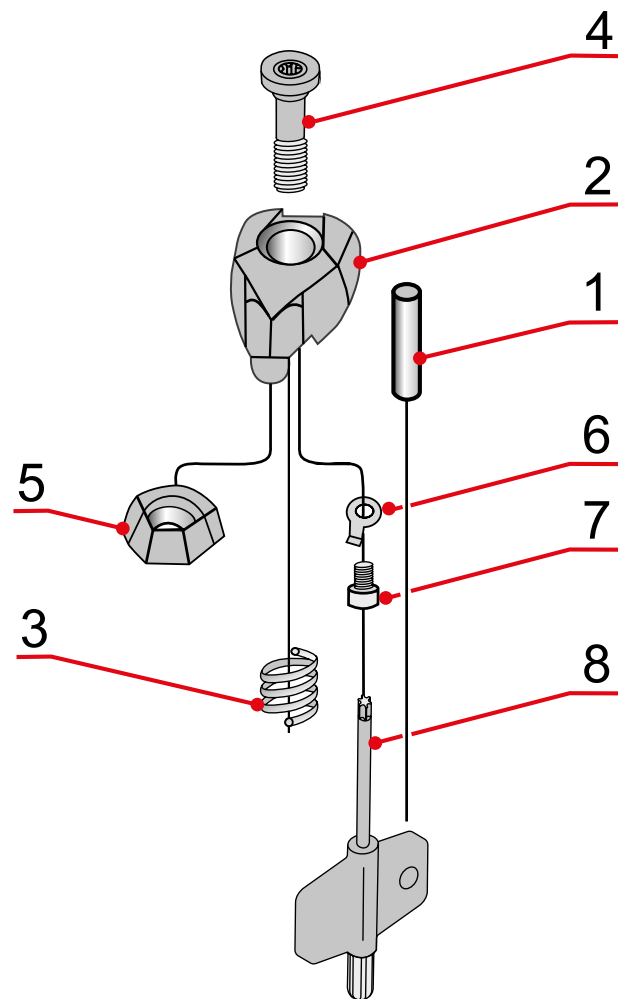

	1	2	3	4		5	6	7	8
DCS 09	CP 2655	CD 09	PR 0157	CS 8601-T09P	1.7	-	-	-	-
DCS 12	CP 2607	CD 12	PR 0158	CS 8602-T15P	3.9	-	-	-	-
DCS 16	CP 2607	CD 16	PR 0159	CS 8603-T20P	6.4	-	-	-	-
DCS 19	CP 2607	CD 19	PR 0159	CS 8603-T20P	6.4	-	-	-	-
DCS 25	CP 2607	CD 25	PR 0101	CS 8604-T25P	9.5	-	-	-	-
DCS 16V	CP 2607	CD 16V	PR 0158	CS 8602-T15P	3.9	-	-	-	-
DCS 12C2	CP 2607	CD 12C2	PR 0158	CS 8602-T15P	3.9	PP 3002	H 1201	CS 9701-T07P	FLAG T07P
DCS 16C2	CP 2607	CD 16C2	PR 0159	CS 8603-T20P	6.4	PP 3003	H 1201	CS 9701-T07P	FLAG T07P
DCS 12C4	CP 2607	CD 12C4	PR 0158	CS 8602-T15P	3.9	PP 3002	H 1201	CS 9701-T07P	FLAG T07P
DCS 16C4	CP 2607	CD 16C4	PR 0159	CS 8603-T20P	6.4	PP 3003	H 1201	CS 9701-T07P	FLAG T07P

UÇ KUTUSU ÜZERİNDEKİ TEKNİK BİLGİLER

Menşei Ülkesi → Made in Czech Republic

Barkod → 3 603602 1189057

Ürün numarası → 80016674 6754539

CNMG 120408-M
CNMG 432-M
Grade T9315

Uç markalama → CNMG 120408-M
Kalite → CNMG 432-M
Miktar → Grade T9315

ANSI Kodu → CNMG 120408-M
Kalite → CNMG 432-M
Miktar → Grade T9315

İç kodu (parti no) → 4443-2208499 80015589 QTY 10

	[metric]	[inch]
P10-P30	v_c 325-205	1065-675
	f_z 0,17-0,60	.007-.024
	a_p 0,8-9,0	.031-.236
M10-M25	v_c 305-190	1000-625
	f_z 0,17-0,60	.007-.024
	a_p 0,8-9,0	.031-.236
S15-S5	v_c 65-40	215-130
	f_z 0,10-0,20	.004-.008
	a_p 0,3-1,5	.012-.059

Metrik birim sütunu → [metric]

İnç birim sütunu → [inch]

Kalite sınıflandırılması → P10-P30

Kalite uygulama aralığı → M10-M25

Öncelik seçimi → S15-S5

Kesme hızı → v_c

İlerleme → f_z

Kesme derinliği → a_p

Kesme derinliği ve ilerlemeye bağlı başlangıç kesme hızı (metrik) → v_c

Kesme derinliği ve ilerlemeye bağlı başlangıç kesme hızı (inç) → v_c

Uç şekli ve talaş oluşumuna bağlı olarak ilerleme (metrik) → f_z

Uç şekli ve talaş oluşumuna bağlı olarak ilerleme (inç) → f_z

Uç şekli ve talaş oluşumuna bağlı olarak kesme derinliği (metrik) → a_p

Uç şekli ve talaş oluşumuna bağlı olarak kesme derinliği (inç) → a_p

Marka etiketi → PRAMET

WARNING! Product may break or shatter in use. Check the application equipment first, could cause permanent respiratory disease, and can irritate nose, throat, skin and eyes. Contains one or more of tungsten carbide, cobalt, nickel, lead Safety Data Sheet. Safety measures to contain dust and to prevent contamination. To avoid injury, use personal protective equipment, including eye protection. Use machine guards and the machine's safety features. This product contains or produces particles which are known to the State of California to cause cancer. (Proposition 65, P65-0114)

SIMPLY RELIABLE

Profesyoneller sadece talaşa bakarak işin kalitesini değerlendirebilir. Bizim talaşımız kendi öyküsünü anlatan pürüzsüz ve basit şekillidir. Açık ve istikrarlı işareten dolayı basitçe güvenilir olmak için sembolümüz olarak talaş şeklini kullanıyoruz.

DORMER PRAMET

Austria

T: +31 10 2080 240
info.at@dormerpramet.com

Belgium & Luxembourg

T: +32 3 440 59 01
info.be@dormerpramet.com

Brazil

T: +55 11 5660 3000
info.br@dormerpramet.com

Canada

T: (888) 336 7637
En Français: (888) 368 8457
cs.canada@dormerpramet.com

China

T: +86 21 2416 0508
info.cn@dormerpramet.com

Croatia

T: +385 98 407 489
info.hr@dormerpramet.com

Czech Republic

T: +420 583 381 111
info.cz@dormerpramet.com

Denmark

T: 808 82106
info.se@dormerpramet.com

Finland

T: 0205 44 7003
info.fi@dormerpramet.com

France

T: +33 (0)2 47 62 57 01
info.fr@dormerpramet.com

Germany

T: +49 9131 933 08 70
info.de@dormerpramet.com

Hungary

T: +36-96 / 522-846
info.hu@dormerpramet.com

India

T: +91 11 4601 5686
info.in@dormerpramet.com

Italy

T: +39 02 30 70 54 44
info.it@dormerpramet.com

Kazakhstan

T: +7 771 305 11 45
info.kz@dormerpramet.com

Mexico

T: +52 (555) 7293981
cs.mexico@dormerpramet.com

Netherlands

T: +31 10 2080 240
info.nl@dormerpramet.com

Norway

T: 800 10 113
info.se@dormerpramet.com

Poland

T: +48 32 78-15-890
info.pl@dormerpramet.com

Portugal

T: +351 21 424 54 21
info.pt@dormerpramet.com

Romania

T: +4(0)730 015 885
info.ro@dormerpramet.com

Russia

T: +7 (495) 775 10 28
info.ru@dormerpramet.com

Slovakia

T: +421 (41) 764 54 60
info.sk@dormerpramet.com

Slovenia

T: +385 98 407 489
info.si@dormerpramet.com

Spain

T: +34 935717722
info.es@dormerpramet.com

Sweden

responsible for Iceland
T: +46 35 16 52 96
info.se@dormerpramet.com

Switzerland

T: +31 10 2080 240
info.ch@dormerpramet.com

Turkey

T: +90 533 212 45 47
info.tr@dormerpramet.com

Ukraine

T: +38 067 566 38 80
T: +38 067 566 81 51
info.ua@dormerpramet.com

United Kingdom

responsible for Ireland
T: 0870 850 4466
info.uk@dormerpramet.com

United States of America

T: (800) 877-3745
cs@dormerpramet.com

Other countries

South America

T: +55 11 5660 3000
info.br@dormerpramet.com

Adria

T: +420 583 381 527
info.rcee@dormerpramet.com

Rest of the World

Dormer Pramet International UK
T: +44 1246 571338
info.int@dormerpramet.com

Dormer Pramet International CZ
T: +420 583 381 520
info.int.cz@dormerpramet.com

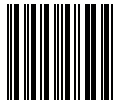

881109

DP-CAT-TURNING-2021-TR

FOLLOW US...



www.dormerpramet.com



youtube.com/dormerpramet



facebook.com/dormerprametsocial



linkedin.com/company/dormerpramet



instagram.com/dormerprametsocial



twitter.com/dormerpramet